

installation guidelines

Secura Lath[®]



ALABAMA METAL INDUSTRIES CORPORATION

GIBRALTAR INDUSTRIES CORPORATION 

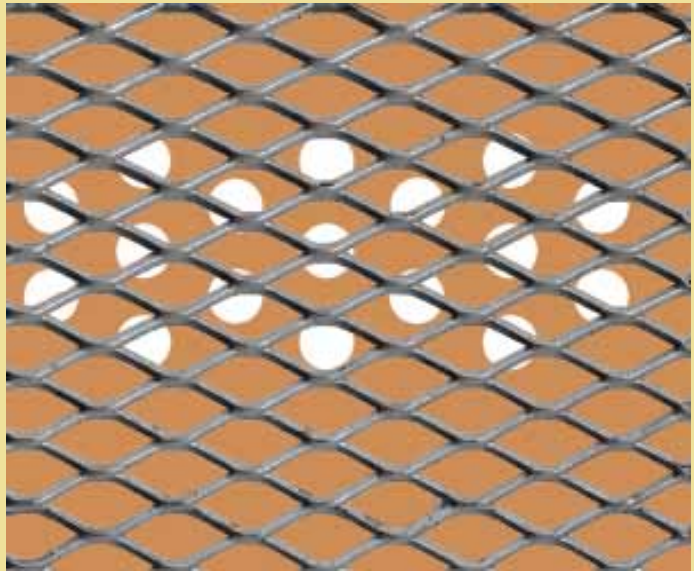

Physical Security Penetration Barrier
for Plaster and Stucco Applications



SECURA LATH®

SECURA LATH INSTALLATION GUIDELINES

PRODUCT DEVELOPMENT

Secura Lath was born out of necessity. After the development of AMICO Security Mesh, specifiers requested that we develop a product that would provide a superior penetration barrier for plaster and stucco applications.

After years of lab and field testing, Secura Lath was ready for market and was introduced in 1994 at the Construction Specifications Institute trade show. Since then hundreds of thousands of square feet of Secura Lath have been installed to the satisfaction of owners, designers, specifiers, and contractors.

PRODUCT DESCRIPTION

Secura Lath (ASL) .50-16R is a 16GA carbon steel expanded metal lathing product that has a 1/2-inch (12.7mm) wide (SWD) by 1-inch (2.54mm) long (LWD) opening. Secura Lath is available pregalvanized prior to expansion and for very unique applications hot dip galvanized after forming. All Secura Lath is provided with perforated kraft paper. One side is vinyl coated to aid in the curing process. This paper is recessed on all four edges approximately 1-1/2 inches (38.1mm) to allow for easier lapping of sheets. The paper is recessed so that it does not interfere with the proper lapping of the Secura Lath. A metal to metal connection at the lap is absolutely essential in order to maintain proper stucco thickness. Variations in stucco thickness will nearly always lead to stucco cracks. This paper is perforated in such a fashion as to allow for proper spacing and attachment with hangar wire to cross furring channels. This paper serves only to control the amount of stucco being applied and to aid in keying and curing.

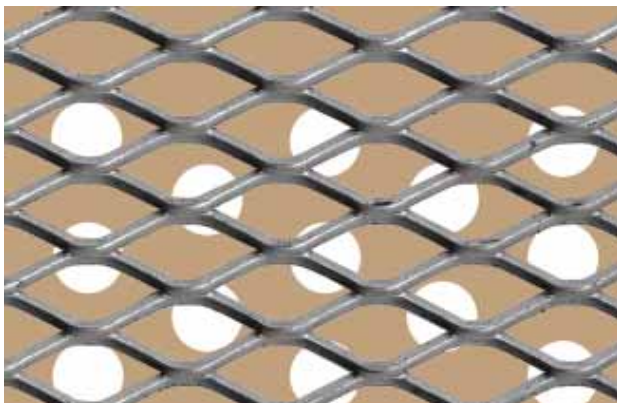

Secura Lath - Penetration barrier for plaster applications

ACCESSORIES

A full line of accessories are available to compliment the installation of AMICO Secura Lath. Among these are corner beads, casing beads, and AMICO expansion/control joints in a wide variety of ground heights up to 1-1/4-inch (31.75mm). AMICO also supplies cold rolled channel, hanger wire, tie wire and all other lathing components for this system. Strip lath and corner lath are available in galvanized only.

TECHNICAL DATA

Secura Lath is provided in a sheet size of 27-inches (.69m) x 97-inches (2.46m). 100 pieces per pallet, at 18.2 square feet (1.69m²) per sheet for a total of 1820 sf (169.1m²).

INSTALLATION

The following installation procedures are taken primarily from the following ASTM specifications:
ASTM C1063 - The Installation of Lathing and Furring for Portland Cement-Based Plaster
ASTM C841 - Installation of Interior Lathing and Furring
ASTM C926 - Application of Portland Cement-Based Plaster

It is imperative that good lathing practices are employed. Please note that in some instances we have exceeded the requirements of ASTM; this is due to the uniqueness of this system, and for security requirements.

***INSTALLATION NOTE:** The nature of this product is such that in order for it to perform properly it must be installed properly. Therefore AMICO's Secura Lath Installation Guidelines must be followed to the letter in order to obtain desired results, and to keep cracking to a minimum. All stucco cracks to some degree due to shrinkage and movement, however if AMICO's Installation Guideline is followed, cracking should be kept to an acceptable level.*

Description	Finish	Sheet Size	Weight
ASL .50-16R	Pre-Galvanized and Paper Backed	27" x 97"	.83 lbs.
ASL .50-16R	Hot Dip-Galvanized and Paper Backed	27" x 97"	1.00 lbs.

SUSPENDED CEILING FRAMING INSTALLATION

The Supporting Framework

AMICO Secura Lath serves as a structural base for the stucco or plaster, and the framing structure is the foundation for the lath. Because Secura Lath is somewhat stouter the framing system has been strengthened and should be installed as follows:

1. Use 8GA 0.1620-inch (4.12mm) galvanized hanger wire for suspension of hangers.
2. Mechanically anchor hanger wires to the ceiling or sub-floor system, by use of drilled and inserted anchors or pre installed loops embedded in the concrete. See ASTM C1063 for other acceptable means of attachment.
3. Spacing of hanger wires: Maximum allowable spacing 24-inches (610mm) on center.
4. Spacing of 1-1/2-inch (38.1mm) x 1/2-inch (12.7mm) leg, galvanized cold rolled channel main runners: maximum allowable spacing 36-inches (914mm) on center.
5. Spacing of 3/4-inch (19mm) x 1/2-inch (12.7mm) leg galvanized cold rolled channel cross furring: Maximum allowable spacing 13-1/2 inches (343mm) o.c. Securely saddle-tie cross furring 3/4-inch (19mm) painted or galvanized cold rolled channel, to main runners with (16 GA) 0.0625-inch (1.59mm) galvanized wire or a double strand of (18GA) 0.0475-inch (1.21mm) galvanized wire.

NOTE: Where hanger wires are not able to hang straight down, a trapez mechanism employing two sets of hanger wires and 1½ inch (38mm) cold rolled channel should be employed to circumvent the obstacle and allow the hanger wires to hang straight down.

The main runner must be located within 6-inches (152mm) of parallel walls, to support the ends of the cross furring. The ends of the main runner must be supported by hangers located not more than 6-inches (152mm) from the ends of all main runners, including at all openings. Where cross furring or main runners are spliced, flanges should be interlocked and overlapped not less than 12-inches (305mm) for main runner and not less than 8-inches (202mm) for cross furring. These splices should be tied near each end of the splice with double loops of (16GA) 0.0625-inch (1.59mm) or double loops of twin strands of (18GA) 0.0475-inch (1.21mm) galvanized wire.

CAUTIONS

Note: Main runners and cross furring must not come into contact with abutting masonry or reinforced concrete walls or partitions, and must maintain a minimum clearance of ½ inch (12.7mm) for cross furring, and a minimum of 1-inch (25.4mm) clearance for main runners. Temporary shoring may be used during plastering, but must be removed upon completion. Failure to do so will restrict the movement of the ceiling and will likely result in stress cracks. When a ceiling is restricted at the perimeter, but is suspended and freely moves up and down in the center; allowable deflections will in all likelihood be exceeded. When portland cement stucco deflects beyond L/360 (approximately 1/3 inch (8.46mm) in a 10 foot (3.048m) span) it will inevitably crack.



Main runners and cross furring must be interrupted at control/expansion joints. Main runner or cross furring should be spliced so as not to interfere with expansion. Splice ties should be clinched only snug enough to allow telescoping. If these splices are too tight, they will hinder the expansion mechanism. These last two points are critical to a properly installed Secura Lath assembly. See attached details for added information.

NOTE: It is imperative at this point to inform (in writing) all trades and the general contractor that all work must be complete above the framing system prior to lathing; live loading of this system will result in structural cracking.

No other material shall be supported by the framing system. All lighting, HVAC vents and equipment, and sprinkler systems must be independently supported from the structural steel or structural concrete. These elements in a high security installation, can exceed 75 pounds (34kg). This concentrated load can easily exceed design loads for this system which are approximately 15 pounds (6.8kg) per square foot.



SECURA LATH®

Lath Preparation

Secura Lath may be cut with abrasive metal cutting blades in a circular saw, with a power shear, and for small areas with hand held channel nippers or bolt cutters which have been ground to fit the diamond shaped openings.

When cutting ASL with power tools one should wear goggles, mask and ear protection, so as to avoid injury.

Suspended Ceiling SECURA LATH INSTALLATION

ASTM C1063 requires that metal lath be lapped a minimum of ½ inch (12.7mm) on the sides and 1-inch (25.4mm) on the ends. ASL should be installed with the long way of the diamond (long way of the sheet) orientated perpendicular to the supports. All laps should occur on a framing member.

ASL should be secured to cross furring with 16 ga. (0.065 inch) (1.65mm) tie wire, a maximum of 7-inches (178mm) apart along the entire length of the cross furring. The lath must also be wire tied at each lap, between framing members at not more than 9-inches (229mm) on center. Also, all joints must be staggered.

NOTE: ASL must not be continuous through expansion/control joints but must be stopped and tied at each side. Proper allowance for movement must be given, this is a priority. Control joints must be either one piece prefabricated “M” type expansion joints with expanded flanges or a two piece expansion joint with narrow flanges. Further expansion/control joint data can be found later in this guideline.

CASING BEAD INSTALLATION

It is imperative that all openings are cased with AMICO X-66 casing beads attached to the Secura Lath to completely isolate the plaster membrane from all protrusions and dissimilar material, which might transfer loads or stress to the stucco membrane. Casings that turn corners should be fabricated from one piece at the corner. This can be accomplished by snipping the expanded flange and the solid portion of the flange all the way to the ground flange. Once snipped the bead can be slowly bent to the appropriate angle. Do not snip the small return angle. This lip is malleable enough to stretch to a rounded corner. This may seem like a tedious process, but separated or sharp corners are much more likely to crack than rounded corners. A detail of this procedure can be located on page 11 of this guideline manual.



SECURA LATH INSTALLATION for Direct Application to Framing Members for Wall and Ceiling Installation

Secura Lath may be applied directly to light gage steel or wood framing members for both wall and ceiling applications. The one critical issue here is that framing loads and stresses must not be transferred to the stucco membrane, and deflection of the framing members must not exceed L/360. Since Secura Lath is naturally self-furring, it can be applied directly to framing members without additional furring mechanisms. “ASTM C1063 allows lath to attach to members up to 1-5/8-inch wide without the need for furring dimples or mechanisms.

Framing must be spaced on 16-inches (406mm) on centers or less, and the lath must be attached with #8 wafer head screws, to each framing member. Spacing between fasteners must not exceed 7-inches (178mm). The lath must also be wire tied at each lap, between framing members at not more than 9-inches (229mm) on center.

Also all joints must be staggered, and ASL should be applied with the long dimension of the sheet perpendicular to the framing members. Lath must not be continuous through expansion/control joints, but must be stopped and tied at each side. Proper allowance for movement must be given, this is a priority. Control joints shall be one piece prefabricated “M” or “J” type expansion joints with expanded flanges or two piece expansion joints which have narrow wings. *As with ceiling installations, it is critical that all lath be split and discontinuous at all expansion joints. Further expansion/control joint data can be found later in this guideline.*

Note: It is imperative that all openings are cased with X-66 casing bead attached to the Secura Lath to completely isolate the plaster membrane from all protrusions and dissimilar material.

Ceiling Perimeter Expansion

Many designers are concerned by the 3/8-inch (9.5mm) space which remains between the edge of the casing bead and the wall with ceiling applications. This could easily be a hiding place for contraband. However, AMICO recommends the use of a light 30Ga or less wall angle, 1½" x 1" (38.1mm x 25.4mm) to close this gap. Refer to the details on pages 8 and 12. Due to the flexibility of this angle, the system is still able to flex up and down and move in all three planes and also serves to close the perimeter.

Sealants and Caulks

Where ceiling perimeter expansion does not utilize the wall angle and casing bead construction, some designers specify that the gap remaining between the casing bead and the wall must be filled with a pick proof caulk or even an epoxy grout. Some of these caulking and sealing products (especially epoxy grout) can be very detrimental to the stucco system by causing the perimeter to be locked in place. As discussed earlier, this will inevitably lead to extensive cracking. We recommend that where sealants are used, that they offer a minimum of 30% elongation. By doing so, the system should be able to flex during any movement of the ceiling. This situation is particularly critical for suspended ceiling applications.

GENERAL DATA

Expansion/Control Joints: For Gypsum Applications

When gypsum cement is used, expansion joints should be spaced to cover a maximum of 1000 square feet (92.9m²) in area. The distance between control joints must not exceed 25-ft (7.6m) in either direction. Install a control joint where the ceiling framing changes direction.

For Portland Cement Applications

When portland cement plaster is used, expansion joints should be placed every 100 square feet (9.29m²) in area. The distance between control joints must not exceed 18 ft (5.5m) in either direction or a length to width ration of 2½ to 1. Install a control/expansion joint where the ceiling framing changes direction. 2-piece expansion joints should be used where dissimilar framing materials intersect. It is critical that all lath, cross furring and main runners are split and discontinuous at all expansion/control joints.

For additional control joint data reference ASTM C 1063 and ASTM C 841.

Stucco Mix

Stucco formulas for portland cement should be derived from ASTM C926 and if gypsum plaster is employed, proper mix information should be formulated per ASTM C842 and C926. When portland cement stucco is used only acrylic finishes should be applied, do not use portland cement finish.

Because every job situation is different, we realize that it would be impossible for us to make specific recommendations about mix formulas. However, we do offer the following installation suggestions which come largely from ASTM C926 and our field experiences.

AMICO recommends that minimum stucco total thickness be equal to 7/8-inch (22.2mm). Quality for all components should comply with accepted ASTM standards for said products. In particular, sand should be clean, free from any foreign objects, and free from any harmful chemicals or elements such as salt or chlorides. Only potable (drinkable, salt free) water should be used.

For moderate use, low abuse interior areas, gypsum plaster may be used in place of portland cement stucco. Some gypsum plasters are capable of achieving very high strengths and have proven acceptable for many security applications.

Stucco Curing

Portland cement stucco application and curing, should be per ASTM C 926, with particular attention paid to moist curing. Provide sufficient cure time and moisture to permit continuous hydration of the stucco. The most effective procedure for curing and time required between coats will be based on climactic and job conditions. Some moisture must be retained in or added back to freshly applied plaster. If the relative humidity is relatively high (above 75% relative humidity), the frequency for rewetting a surface may be reduced. If it is hot, dry and /or windy, the frequency of rewetting must be increased.

Where artificial heat sources are utilized, moist curing applications are required to prevent excess drying of the stucco prior to curing. Also, adequate ventilation must be provided. Artificially heated areas can evaporate moisture from



SECURA LATH®

the stucco membrane at a rapid rate, causing the stucco to become weak and brittle.

Allow sufficient time between coats to permit each coat to cure or develop enough rigidity to resist cracking or other physical damage when the next coat is applied. Contact EIFS finish manufacturers for information on recommended curing times for the brown coat of stucco, before the application of the acrylic finish.

Additives

It is our recommendation that AR (Alkali resistant) fibers be used in the scratch coat to give extra strength to the stucco. We also recommend that an acrylic modifier product be added to the mix, in place of lime. Industry test data indicates that traditional 1:3 ratio of portland cement and sand stucco, reaches a compressive strength of approximately 1800 pounds per square inch (816KG) in 28 days. Tests also indicate that additives such as Kel-Crete, or PRF when added at a rate of 3 ounces (88.7ml) per sack of cement, raises the compressive strength to more than 3000 pounds per square inch (1361KG) after curing for 28 days. AMICO did not perform these tests, nor does AMICO manufacture or sell these additives. However, the data was published in a nationally publicized and well respected trade journal. You should contact the manufacturers of these additives for specific data and performance ratings on their products.

Technical Assistance

If you require additional assistance, please contact the Alabama Metal Industries Security Products Department at 800-366-2642.

WARRANTY

This AMICO product is warranted to the finished product specification as to the physical and chemical properties of the raw material used if requested prior to the sale and expressly stated by AMICO and AMICO's supplier. It is limited to one year from the date of purchase if product is used for its intended purpose. This information herein is accurate and reliable to the best of our knowledge. AMICO has no control over installation, workmanship, accessories, complementary materials, or conditions of application and therefore, cannot be responsible for these areas of product performance. THE EXECUTIVE REMEDY FOR ANY BREACH OF WARRANTY IS REPLACEMENT OF THE PRODUCT OR A REFUND OF THE PURCHASE PRICE AT AMICO'S OPTION.

THE ABOVE STATED WARRANTIES AND REMEDY IS THE ONLY WARRANTY MADE AND AMICO DISCLAIMS ANY OTHER WARRANTY EXPRESSED OR IMPLIED, INCLUDING BUT NOT LIMITED TO THE IMPLIED WARRANTIES OF MERCHANTABILITY AND FITNESS FOR A PARTICULAR PURPOSE.



AMICO SECURA LATH APPLICATION



Cutting Secura Lath Sheets

SECTION 09 57 53

PHYSICAL SECURITY PENETRATION BARRIER FOR PLASTER AND STUCCO APPLICATIONS

PART 1 - GENERAL

1.1 DESCRIPTION OF WORK

Included work is not limited to the supply and installation of a complete in place security lath structural base for portland cement stucco or high strength gypsum plaster plus all complimentary accessories.

1.2 SYSTEM DESCRIPTION

Secura Lath is a substrate that acts as a penetration barrier for plaster and stucco installations typically and around bath and kitchen areas of correctional facilities.

1.3 SUBMITTALS

Product Data: Submit manufacturers' literature and Secura Lath Installation Guidelines for Walls and Ceilings.

1.4 QUALITY ASSURANCE

The contractor must have adequate experience with the construction methods involved with plaster and stucco installations.

1.5 REFERENCES

Shall be certified Secura Lath by the manufacturer. Secura Lath exceeds the requirements of ASTM C847 and ASTM C1063. Secura Lath is not specifically covered by current ASTM Lath specifications, but due to its weight and strength it exceeds current metal lath specifications. General requirements for expanded metal steel – ASTM A1011 and ASTM F1267. Underwriters Laboratories Rated Assemblies will not be jeopardized by using ASL in the fire rated assembly. (U/L Subject File #1857)

1.6 STORAGE AND HANDLING

Materials shall be stored in a clean dry location with proper ventilation to avoid damage from moisture. Materials shall be protected against damage from weather, vandalism, and theft. In event of freight damage, note freight bill and contact manufacturer immediately .

PART 2 – PRODUCTS

2.1 MANUFACTURER

Physical penetration barrier shall conform to ASL .50-16R as manufactured by Alabama Metal Industries Corporation (AMICO), Birmingham, Alabama. Security Products Department:
Telephone 800/366-2642.
Facsimile 205/786-6527
www.amico-securityproducts.com

2.2 MATERIALS

The carbon steel used in the manufacture of the expanded lathing product shall meet ASTM A 1011/1011M and the requirements of F 1267. Exanded metal lathing not manufactured specifically for security purposes is not permitted for this use.

Perforated kraft paper shall be vinyl coated one side and shall be factory attached to the metal lathing. Perforations allow the wire tying of the steel lathing to the carrying channel. The vinyl-coated paper encourages the complete embedment of the lath and a uniform stucco thickness.

2.3 FINISH

TO BE SELECTED BY SPECIFIER

A. Pre-Galvanized Finish – for standard installations the Secura Lath shall be pre-galvanized prior to both the expanding process and the factory applied paper backing.

or

B. Hot-Dip Galvanized Finish - suggested for high moisture installations, Secura Lath shall be hot-dip galvanized after the expanding process and prior to the factory attachment of the paper backing.

Description	Finish	Sheet Size
ASL .50-16R	Pre-Galvanized and Paper Backed	27" x 97"
ASL .50-16R	Hot Dip-Galvanized and Paper Backed	27" x 97"

PART 3 – EXECUTION

3.1 INSTALLATION

A. Secura Lath physical penetration barrier must be installed to the letter per the AMICO Secura Lath Installation Guidelines to obtain desired results and to keep cracking to a minimum. All stucco will crack to some degree due to shrinkage and movement, however by following the Installation Guidelines implicitly; cracking should be kept to an acceptable level.

B. The AMICO Secura Lath Installation Guidelines procedures follow ASTM C1063, ASTM C841, and ASTM C926. In some instances Secura Lath will exceed these specs due to security requirements and the uniqueness of this system.

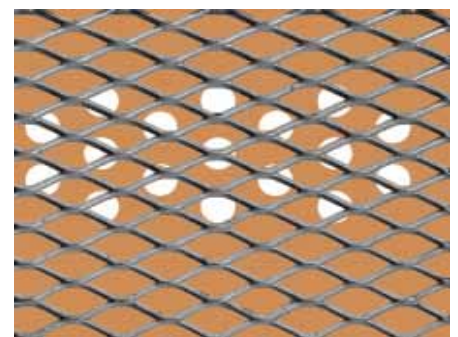
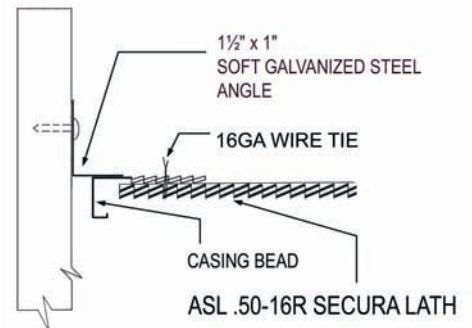

AMICO
ALABAMA METAL INDUSTRIES CORP.
3245 Fayette Avenue
Birmingham, AL 35208
Tel 800/366-2642
Fax 205/786-6527
www.amico-securityproducts.com

SECURA LATH CEILING PERIMETER EXPANSION CONTROL AND UP-LIFT PREVENTION

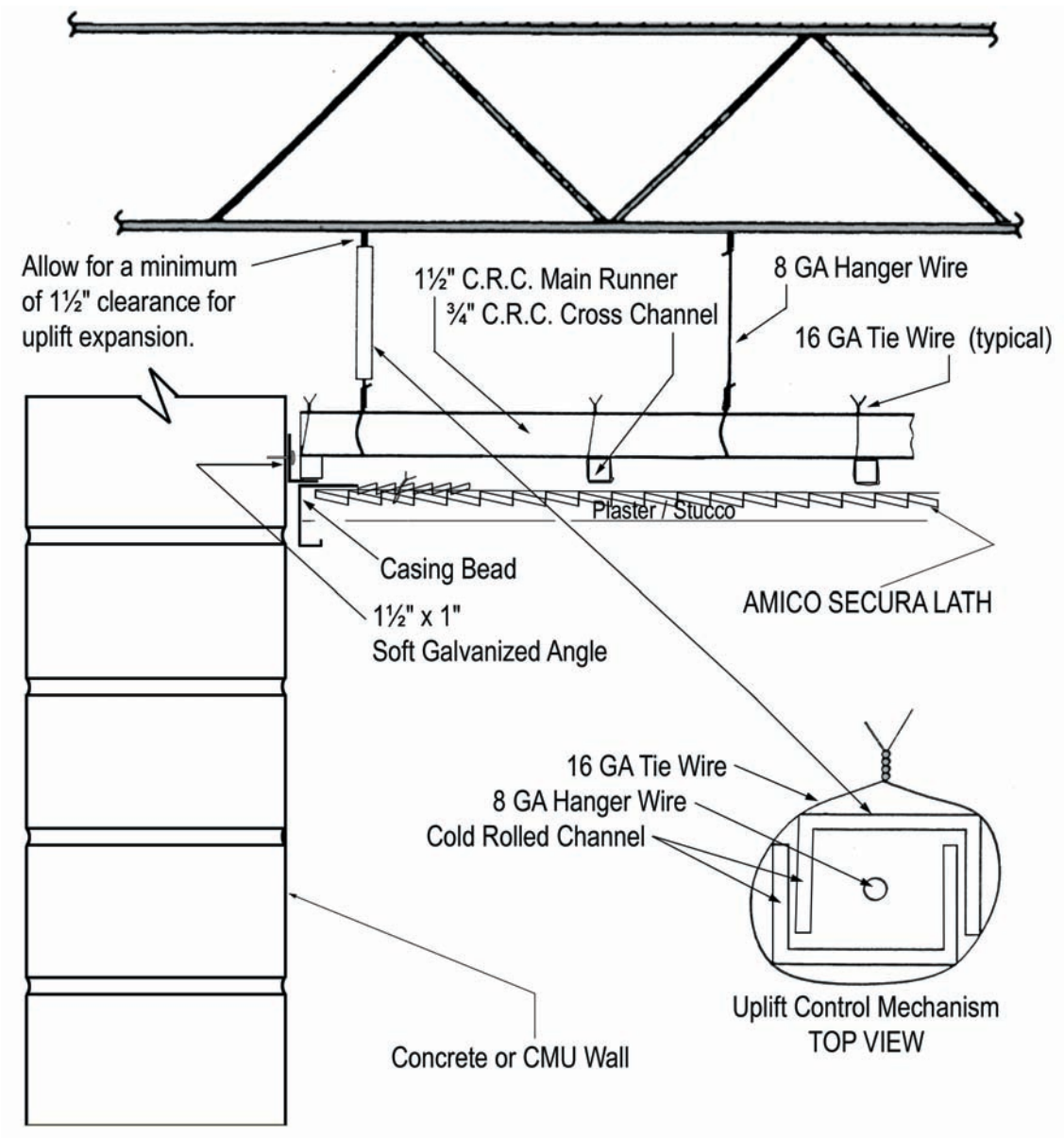

Drawing Name SECURA LATH CEILING PERIMETER EXPANSION CONTROL AND UPLIFT PREVENTION	Drawing 8
	Date 01/15/08
Contact AMICO Security Department	
Manufactured By Alabama Metal Industries Corporation 3245 Fayette Avenue Birmingham, AL 35208 800/366-2642 Fax 205/786-6527 www.amico-securityproducts.com	



CEILING EXPANSION JOINT DETAILS

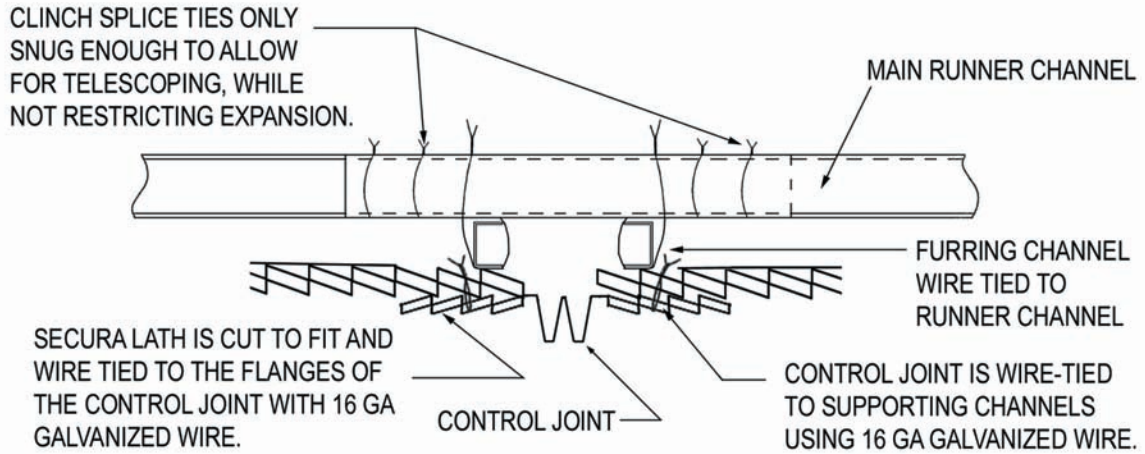

CONTROL JOINT PARALLEL TO FURRING CHANNEL

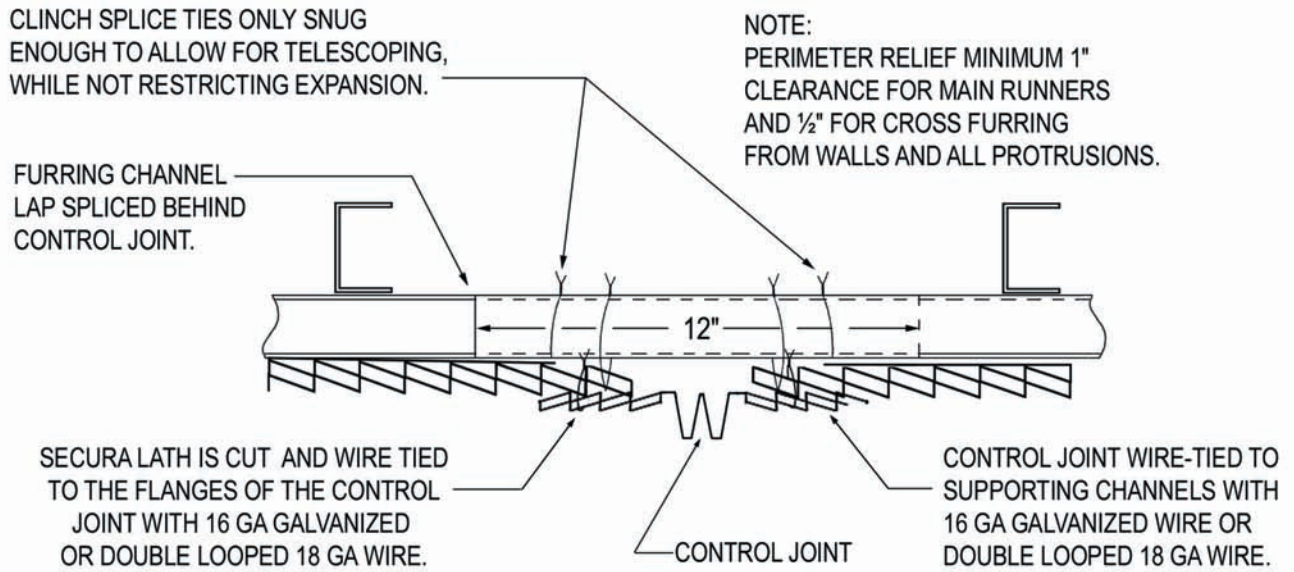

CONTROL JOINT PERPENDICULAR TO FURRING CHANNEL

Drawing Name	Drawing	9
Secura Lath Expansion Joint Details	Date	01/15/08
Contact		
AMICO Security Department		
Manufactured By		
Alabama Metal Industries Corporation		
3245 Fayette Avenue		
Birmingham, AL 35208		
800/366-2642		
Fax 205/786-6527		
www.amico-securityproducts.com		



SECURA LATH CEILING DETAILS

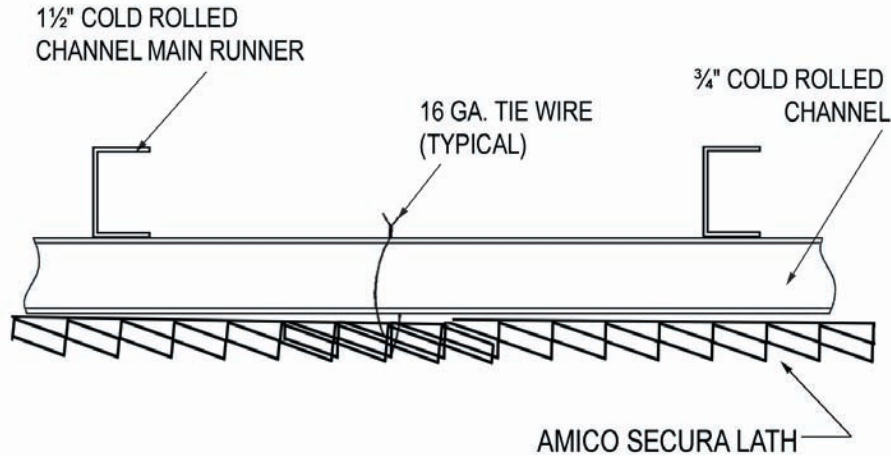

TYPICAL LAP JOINT WIRE-TIED

Cut Casing Bead base flange only (do not cut 1/4" reveal flange) and bend casing to 90° and carry terminal end at least 6 inches beyond the corner. Flatten bulged reveal at corner with light hammer taps to straighten and flush up with straight length to reveal. Wire-tie casing bead on top of casing security mesh. Place Secura Lath on top of casing the bead wing and wire-tie casing bead in conventional manner.

If light fixtures, security grills, sprinkler pipes, or other penetrating elements are rigidly anchored, you must hold the casing bead (plaster boundary) away from the fixture a minimum of 1/8 inch.

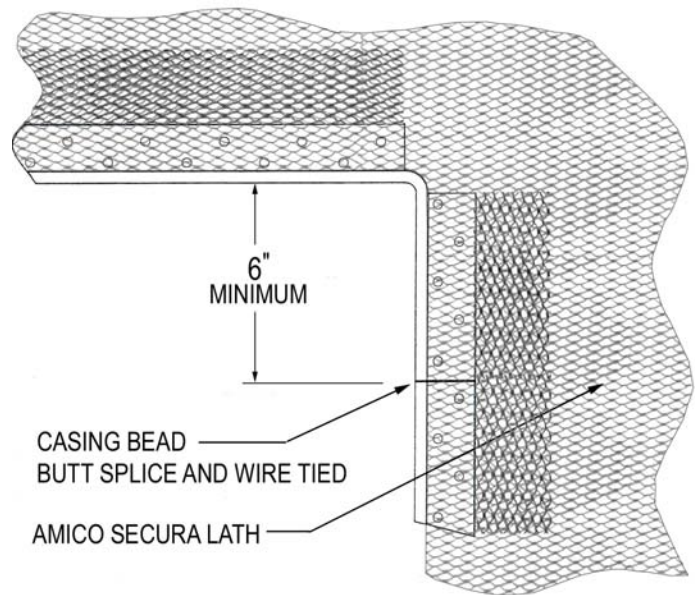

TYPICAL CEILING OPENING

Drawing Name	Drawing 10
Secura Lath Ceiling Details	Date 01/15/08
Contact AMICO Security Department	
Manufactured By Alabama Metal Industries Corporation 3245 Fayette Avenue Birmingham, AL 35208 800/366-2642 Fax 205/786-6527 www.amico-securityproducts.com	



LIGHT & HVAC FIXTURES ISOLATED IN STUCCO CEILING PREFERRED METHOD

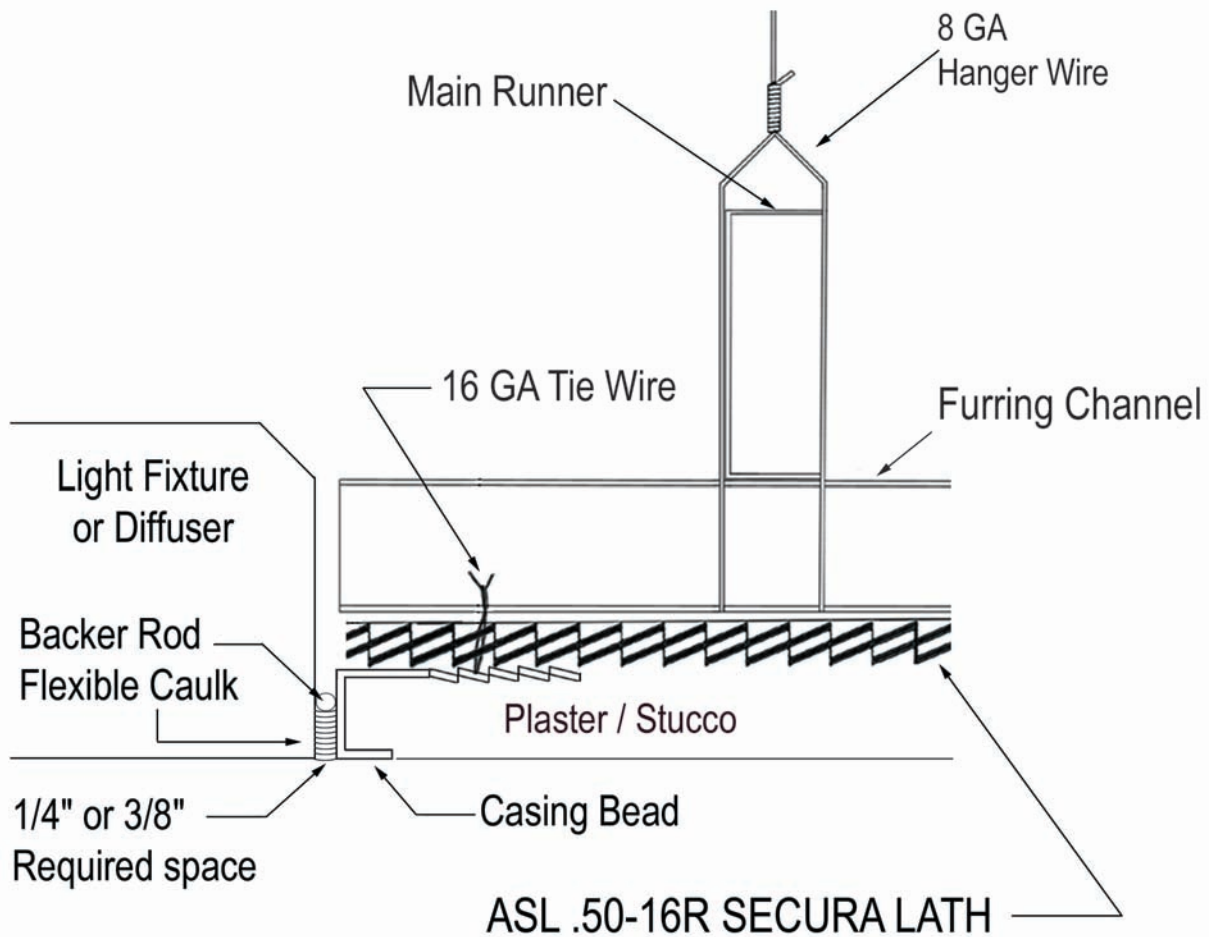

- Notes: 1) Casing Bead To Completely Isolate The Ceiling From All Vertical protrusions.
 2) Light Fixture Or Diffuser Should Not Have Built In Casing Bead.

Drawing Name Secura Lath and Isolated Fixture Details	Drawing 11
	Date 01/15/08
Contact AMICO Security Department	
Manufactured By Alabama Metal Industries Corporation 3245 Fayette Avenue Birmingham, AL 35208 800/366-2642 Fax 205/786-6527 www.amico-securityproducts.com	



Perimeter Ceiling Expansion Using AMICO X-66 Casing Bead and Galvanized Steel Angle

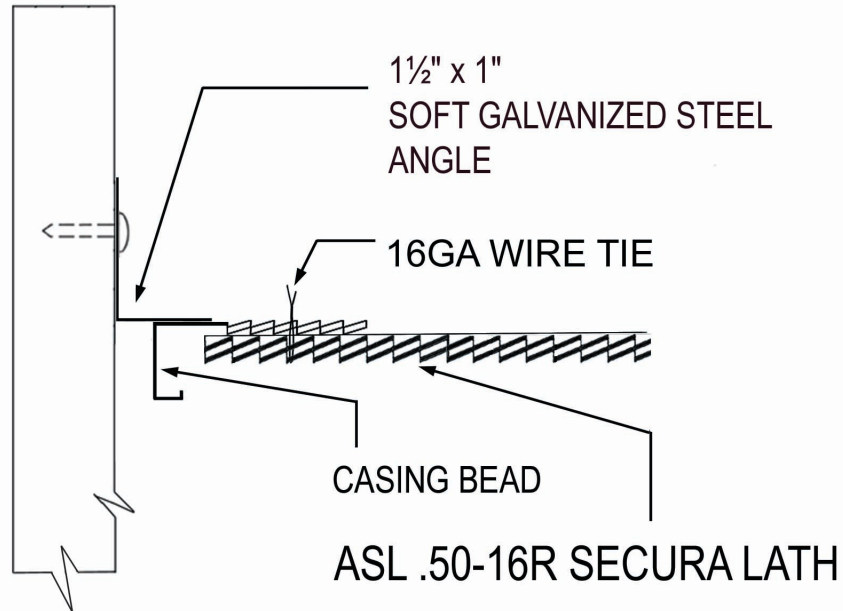

The AMICO X-66 Casing Bead and Angle are designed for use as a perimeter closure for use with the AMICO Secura Lath ceiling system. X-66 Casing Bead is available with grounds up to 1 1/4". 1 1/2" x 1" galvanized Angle must be 30GA or lighter to provide adequate flexibility and the cavity should remain unfilled.

Traditionally a minimum of 3/8" to 1/2" gap must be left between the ceiling and the intersecting walls on all suspended ceiling applications. This gap is generally not acceptable in security applications, therefore the applicator is tempted due to necessity to seal this gap with a caulk of some sort. Often times this is a caulk that is not flexible enough to allow the necessary amount of movement to prevent excessive cracking due to deflection.

X-66 Casing Bead and 30GA steel angle can effectively cover the expansion gap at the ceiling perimeter while still allowing for movement in all three planes, (in-and-out, side-to-side, and up-and-down). Up-and-down movement is critical and is accomplished by using a very light gauge metal that is designed to be flexible enough to allow for adequate movement of the ceiling and strong enough to resist tampering.

For further technical information, contact AMICO's Security Department at 800/366-2642.

Drawing Name AMICO Secura Lath Perimeter Ceiling Expansion	Drawing 12
	Date 01/15/08
Contact AMICO Security Department	
Manufactured By Alabama Metal Industries Corporation 3245 Fayette Avenue Birmingham, AL 35208 800/366-2642 Fax 205/786-6527 www.amico-securityproducts.com	

