



Armor-Tile[®]
Tactile Systems

CAST-IN-PLACE
Tactile Warning Surface Panels



Armor-Tile®

Tactile Systems

CAST IN PLACE

Innovative System

Armor-Tile® Cast in Place is the world leader in tactile walking surface indicators systems. Manufactured of high-strength polymer composite, Armor-Tile truncated dome and wayfinding bar tiles are the industry leader for durability, weather, and wear resistance. Armor-Tile also is available as a replaceable cast-in-place, modular paver, surface applied, and directional bars.

Tactile Walking Surface Indicators (TWSI) products for the following and many more applications:

- Curb Ramps
- Pedestrian Crossings
- Vehicular Passage Ways
- Escalator Approaches
- Parking Areas
- Transit Platforms
- Top of Stair Landings / Wheelchair Ramps
- Multi-Modal Transit Stations

PRODUCT FEATURES

- The most cost-effective method for compliant curb ramps
- A smooth transition that meets Accessibility Codes
- Lightweight and easy to handle
- Easily cut to conform to various sizes and radius ramps
- Available in seven (7) different sizes to meet your needs
- Comes in ten (10) standard colors
- 5-year manufacturer's warranty

NEW PATTERN

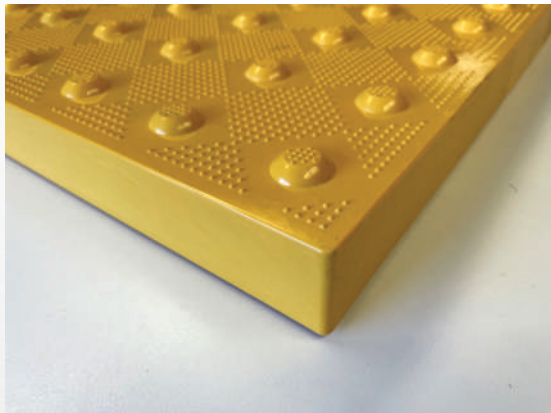
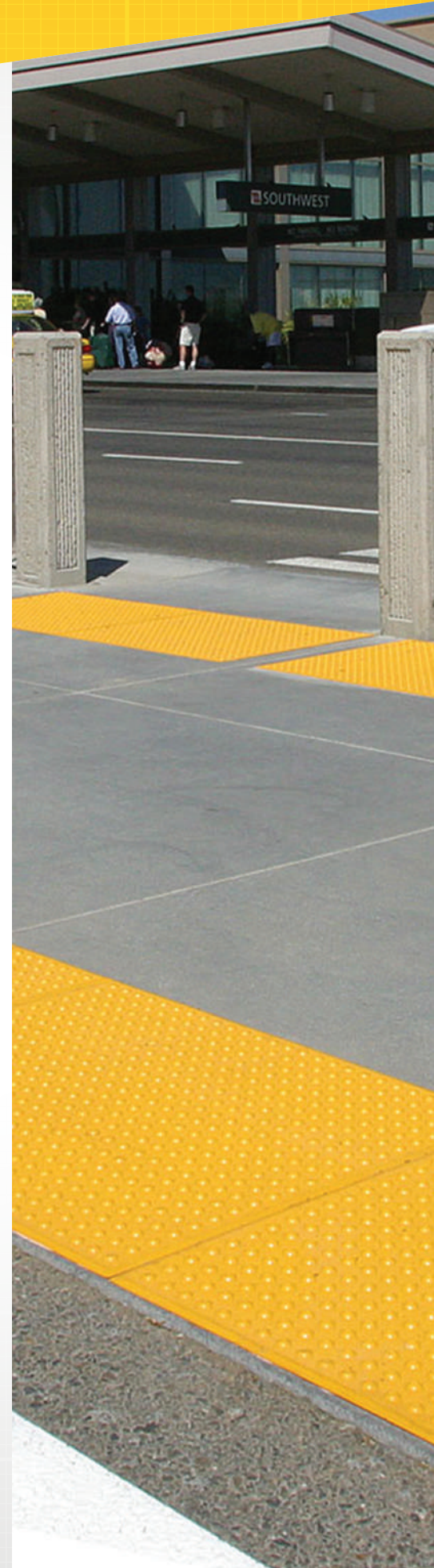
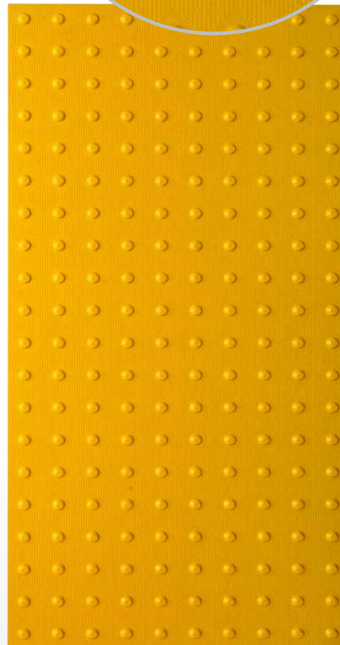
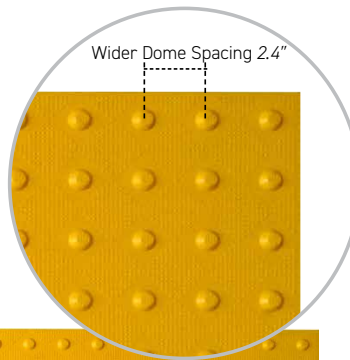

ARMOR-TILE
RADIUS CALCULATOR
go to <https://new.armor-tile.com>



Armor-Tile®

Tactile Systems



TACTILE WALKING SURFACE INDICATOR (TWSI) WITH TRUNCATED DOMES

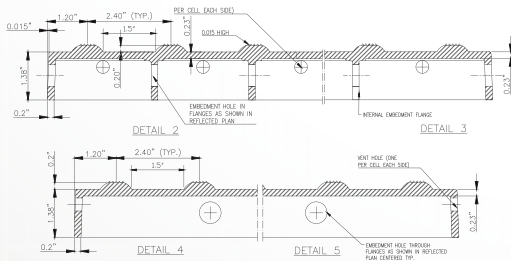
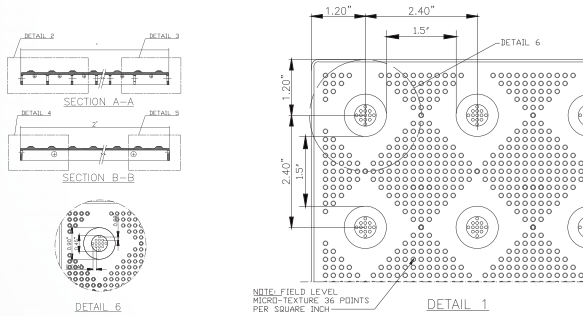
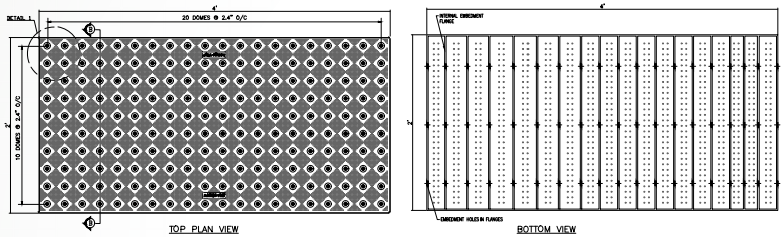

STANDARD CAST-IN-PLACE SIZES

SIZE	PRODUCT CODE
12" x 12" (305 x 305 mm)	ADA-C-1212
24" x 24" (610 x 610 mm)	ADA-C-2424
24" x 36" (610 x 915 mm)	ADA-C-2436
24" x 48" (610 x 1220 mm)	ADA-C-2448
24" x 60" (625 x 1524 mm)	ADA-C-2460
36" x 48" (915 x 1220 mm)	ADA-C-3648
36" x 60" (915 x 1524 mm)	ADA-C-3660

STANDARD COLORS

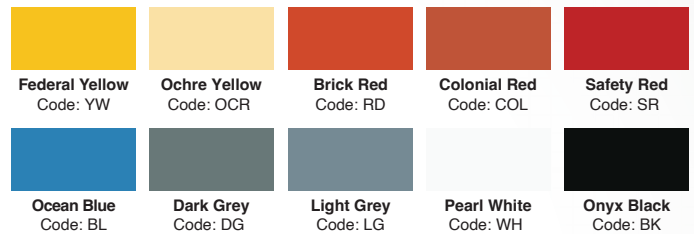

CUSTOM COLORS

Large variety available. Let us know how we can help.

APPLICATIONS

TWSI Truncated Domes

- Curb ramps and blended transitions at pedestrian street crossings
- Pedestrian refuge islands
- Pedestrian at-grade rail crossings not located within a street or highway
- Boarding platforms at transit stops for buses and rail vehicles where the edges of the boarding platform are not protected by screens or guards
- Boarding and alighting areas at sidewalk or street level transit stops for rail vehicles where the side of the boarding and alighting areas facing the rail vehicles is not protected by screens or guards.



Armor-Tile

Tactile Systems

SECTION 32 17 26 - TACTILE WARNING SURFACE DETECTABLE WARNING SURFACE PANELS CAST-IN-PLACE

PART 1 GENERAL

1.01 RELATED DOCUMENTS

- A. Drawings and general provisions of Contract, including General and Special Conditions and Division 1 Specifications Section, apply to this Section.

1.02 DESCRIPTION

- A. This Section specifies furnishing and installing Cast-In-Place Detectable Warning Surface Panels where indicated. Not recommended for asphalt applications.

1.03 SUBMITTALS

- A. Product Data: Submit manufacturer's literature describing products, installation procedures, and routine maintenance.
- B. Samples for Verification Purposes: Submit two (2) samples minimum 12" x 12" (305 x 305 mm) of the kind proposed for use.
- C. Shop drawings are required for products specified showing fabrication details, panel surface profile, fastener locations, plans of panel placement including joints, and material to be used as well as outlining installation materials and procedure.
- D. Material Test Reports: Submit complete test reports from qualified accredited independent testing laboratories to qualify that materials proposed for use are in compliance with requirements and meet or exceed the properties indicated on the specifications.
- E. Maintenance Instructions: Submit copies of manufacturer's specified installation and maintenance practices for each type of detectable warning surface panel.

1.04 QUALITY ASSURANCE

- A. Provide Cast-In-Place Detectable Warning Surface Panels and accessories as produced by a single manufacturer with a minimum of three (3) years experience in the manufacturing of tactile walking surface products.
- B. Installer's Qualifications: Engage an experienced installer who has successfully completed installations similar in material, design, and extent to that indicated for Project.
- C. Cast-In-Place Detectable Warning Surface Panels shall be compliant with the following guidelines and requirements (applicability may be dependent on project location):

Armor-Tile

Tactile Systems

[APPLICABLE TO UNITED STATES]

- a. American Barriers Act (ABA) Accessibility Standards
- b. ADA Accessibility Guidelines (ADAAG)
- c. Department of Transportation ADA Standards for Transportation Facilities (2006)
- d. Department of Justice ADA Standards (2010)
- e. Public Rights-of-Way Accessibility Guidelines (PROWAG)
- f. California Building Standards Code, Title 24, California Code of Regulations
- g. Texas Accessibility Standards (TAS) 2012
- h. AASHTO M 333 Standard Specification for Detectable Warning Surfaces
- i. International Code Council (ICC) A117.1 Accessible and Usable Buildings and Facilities

[APPLICABLE TO CANADA]

- a. ISO 23599:2012(E): Assistive Products for Blind and Vision Impaired Persons – Tactile Walking Surface Indicators
- b. CSA B651-18: Accessible Design for the Built Environment Standard – Section 4.3.5
- c. Integrated Accessibility Standards Regulation 191/11 – Sections 80.25 to 80.29
- d. Ontario Building Code 3.8.3.18. Tactile Attention Indicators
- e. National Building Code of Canada: Section 3.3.1.19 Tactile Walking Surface Indicators

- D. Cast-In-Place Detectable Warning Surface Panels shall be manufactured from fiberglass reinforced polymer composite. Panels shall incorporate the following design elements:
- a. In-line pattern of truncated domes oriented parallel to panel edges
 - b. Dome height of 0.20" (5 mm)
 - c. Dome base diameter of 0.9" (23 mm)
 - d. Dome top diameter of 0.45" (12 mm)
 - e. Dome spacing of 2.35" (60 mm) to 2.40" (61 mm) center to center
 - f. Traction elements on top of domes and in the field between dome bases shall consist of a micro texture of raised points 0.05" high (1.2 mm)
- E. Cast-In-Place Detectable Warning Surface Panels shall meet or exceed the following test criteria using the most current test methods:

Test Method	Test Description	Value
ASTM D 695	Compressive Strength	≥ 28,900 psi
ASTM D 790	Flexural Strength	≥ 21,000 psi
ASTM D 638	Tensile Strength	≥ 11,000 psi
ASTM D 570	Water Absorption	≤ 0.05%
ASTM C 1028	Slip Resistance	≥ 0.80 wet/dry
ASTM E 84	Flame Spread Index	≤ 25
ASTM B 117	Salt Spray	No Effect
ASTM 1308	Chemical Stain	No Effect
ASTM C 501	Abrasion Resistance (lw)	> 500
ASTM G 155	Accelerated Weathering (2000hrs)	ΔE < 5
AASHTO-H20	Load Bearing at 10,410 lbs.	No Effect
ASTM C 1026	Freeze/Thaw/Heat	No Effect
ASTM D 1037	Accelerated Aging	No Effect

Armor-Tile

Tactile Systems

1.05 DELIVERY, STORAGE AND HANDLING

- A. Cast-In-Place Detectable Warning Surface Panels shall be packaged to prevent damage in shipment or handling. Finished surfaces shall be protected by sturdy wrappings and products shall be identified by part number.
- B. Cast-In-Place Detectable Warning Surface Panels shall be delivered to a location at the building site for storage before installation. Store panels in an area that is within an acceptable temperature range 40°F - 90°F (4°C - 32°C) and maintain the storage facility in a clean, dry condition to prevent contamination or damage to the panels.

1.06 SITE CONDITIONS

- A. Environmental Conditions and Protection: Maintain minimum temperature of 40°F (4°C) in spaces to receive Cast-In-Place Detectable Warning Surface Panels for at least 24 hours prior to installation, during installation, and for not less than 24 hours after installation.

1.07 WARRANTY

- A. Cast-In-Place Detectable Warning Surface Panels shall be warranted by the manufacturer in writing for a period of five (5) years from date of final completion. The guarantee includes manufacturing defects, breakage, and deformation.
- B. Cast-In-Place Detectable Warning Surface Panel installation shall be warranted in writing for two (2) years by the installer. Products must be guaranteed from defective work and loosening of panels.

PART 2 PRODUCTS

2.01 MANUFACTURERS

- A. **Armor-Tile** Cast-In-Place Detectable Warning Surface Panels as manufactured by **SureWerx**, 325 Corporate Drive, Elgin, Illinois 60123. Phone 844-697-2920, orders.ci.usa@surewerx.com, www.armor-tile.com/
- B. Panel Sizes:
 - 1. 12" x 12" (305 x 305 mm)
 - 2. 24" x 24" (610 x 610 mm)
 - 3. 24" x 36" (610 x 915 mm)
 - 4. 24" x 48" (610 x 1220 mm)
 - 5. 24" x 60" (610 x 1524 mm)
 - 6. 36" x 48" (915 x 1220 mm)
 - 7. 36" x 60" (915 x 1524 mm)
- C. Color: Color shall be single, homogeneous color throughout panel and be close approximation of the following AMS-STD-595 color numbers:
 - 1. Federal Yellow (YW), Color No. 33538

Armor-Tile

Tactile Systems

2. Brick Red (RD), Color No. 22144
3. Colonial Red (COL) Color No. 20109
4. Safety Red (SR) No. 31350
5. Onyx Black (BK) No. 17038
6. Dark Gray (G) No. 36118

2.02 MATERIALS

- A. Composition: Cast-In-Place Detectable Warning Surface Panels shall be manufactured using an exterior grade homogeneous (uniform color throughout thickness of product) fiberglass reinforced polyester based composite material. Truncated domes must contain fiberglass reinforcement within the truncated dome for superior structural integrity and impact resistance. Use of tactile warning surface products employing colored coatings is expressly prohibited.

PART 3 EXECUTION

3.01 PREPARATION

- A. During all concrete pouring and panel installation procedures, ensure adequate safety guidelines are in place and that they are in accordance with the applicable industry and government standards.
- B. The physical characteristics of the concrete shall be consistent with the Contract Specifications while maintaining a slump range of 4 - 7 to permit solid placement of the panel.
- C. An overly wet mix will cause the panel to float. Under these conditions, suitable weights such as 2 concrete blocks or sandbags (25 pounds) shall be placed on each panel.
- D. The concrete shall be poured and finished, true and smooth to the required dimensions and slope prior to panel placement.

3.02 EQUIPMENT

- A. Contractor shall provide all tools, equipment, and services required for satisfactory installation per manufacturer's instruction as Incidental Work. Equipment which may be required include typical mason's tools, a 4-foot level with electronic slope readout, 25 lb. (11.4 kg) weights, vibrator, rubber mallet with 2" x 4" x 10" (51 mm x 102 mm x 254 mm) wood tamping plate, and a device for cutting the Detectable Warning Surface Panels.

3.03 INSTALLATION

- A. Contractor will not be allowed to install panels until all submittals have been reviewed and approved by the Engineer. Panels shall be installed according to the manufacturer's instructions.
- B. To the maximum extent possible, the panels shall be oriented such that the rows of in-line truncated domes are parallel with the direction of the ramp. When multiple panels regardless of

Armor-Tile

Tactile Systems

size are used, the truncated domes shall be aligned between the panels and throughout the entire tactile warning surface installation.

- C. In accordance with the Accessibility Guidelines for Pedestrian Facilities in the Public Rights of Way 2011, panels shall be located relative to the curb line as shown within Sections 304 and 305 of the Guidelines.
- D. Panels shall be tamped or vibrated into the fresh concrete to ensure that there are no voids or air pockets, and the field level of the panel is flush to the adjacent concrete surface or as the Drawings indicate to permit proper water drainage and eliminate tripping hazards between adjacent finishes.
- E. Panels shall be cut into size and configuration indicated on the Drawings using a 60 tooth carbide blade on a table saw or equivalent cutting device. Minimize any cantilever effect (to the maximum extent practicable) when cutting between successive embedment ribs as concrete will tend to flow up and over the panels. The top of the body of the panel shall be fully seated and flush with the adjacent concrete substrate. For specific instructions for cutting and setting refer to Detectable Warning Surface manufacturer's written instructions.

3.02 CLEANING, PROTECTING, AND MAINTENANCE

- A. Protect panels against damage during construction period.
- B. Protect panels against damage from rolling loads following installation by covering them with plywood or other protective measures.
- C. Clean panels not more than four days prior to scheduled date for inspection intended to establish date of substantial completion in each area of project. Clean panels by method specified by manufacturer.
- D. Comply with manufacturer's maintenance manual for cleaning and maintaining panel surface and it is recommended to perform annual inspections for safety and panel integrity.

END OF SECTION

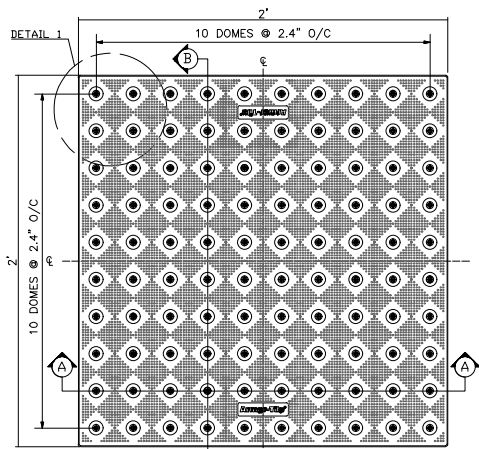

TOP PLAN VIEW

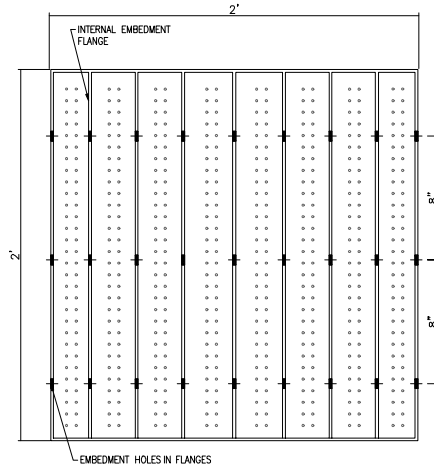

BOTTOM VIEW

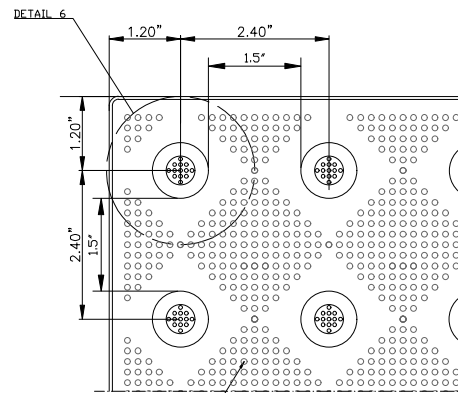

NOTE: FIELD LEVEL MICRO-TEXTURE 36 POINTS PER SQUARE INCH

DETAIL 1

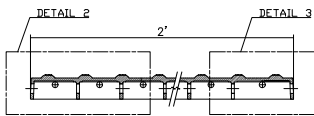

SECTION A-A

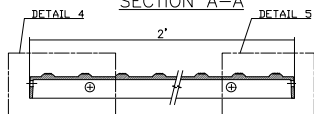

SECTION B-B

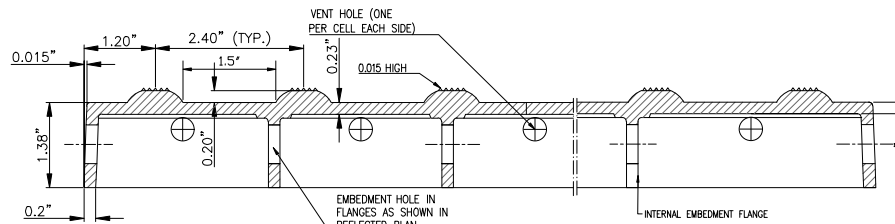

DETAIL 2

DETAIL 3

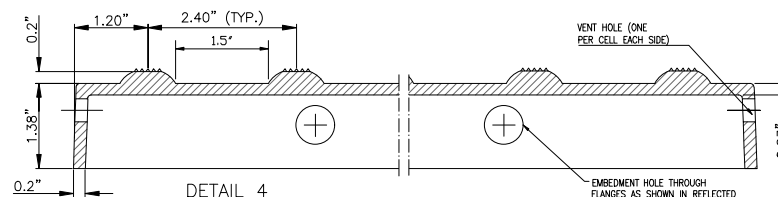

DETAIL 4

DETAIL 5

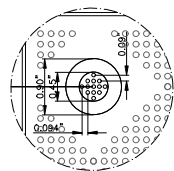

DETAIL 6

Armor-Tile



MATERIAL LIST

#	DESCRIPTION	PART No:	QTY
1	ARMOR-TILE	ADA-C-2424W	1

NOTE: ALL DIMENSIONS ARE NOMINAL WITH A TOLERANCE OF ±0.05

No:	DATE	REVISION	APPR.

SCALE

N.T.S.

DESIGNED	K.S.	
DRAWN	M.T.	
DRAWN	M.T.	07/15/2024

DETECTABLE WARNING SURFACE ADA-C-2424W

FIBERGLASS REINFORCED POLYMER COMPOSITE

Armor-Tile™ ADA

Armor-Tile™

DETECTABLE/TACTILE WARNING SURFACE TILE 24"x24" CAST IN PLACE INLINE DOME TACTILE TILE PLANS AND DETAILS

ADA-C-2424W

01

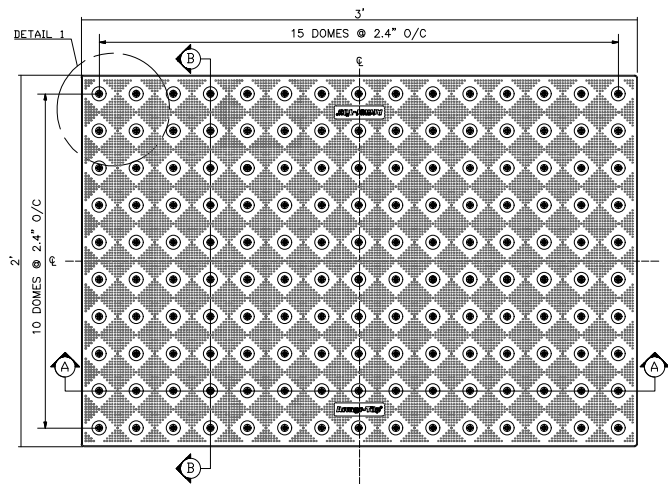

TOP PLAN VIEW

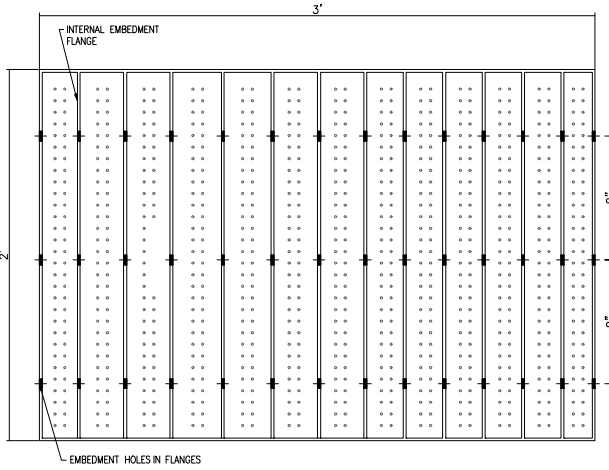

BOTTOM VIEW

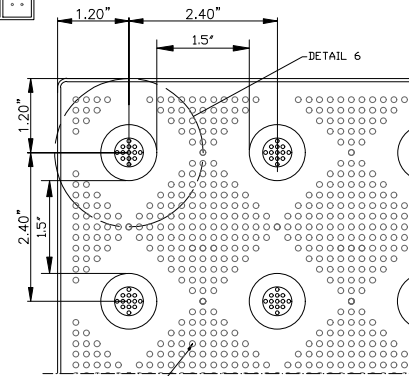

DETAIL 1

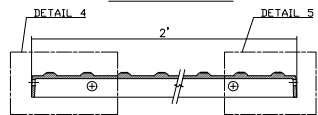
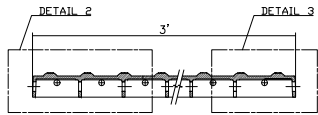

SECTION B-B

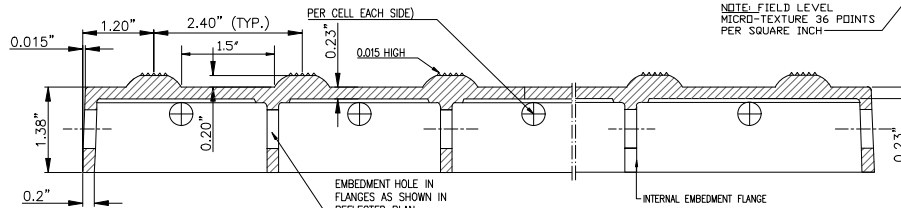

DETAIL 2

DETAIL 3

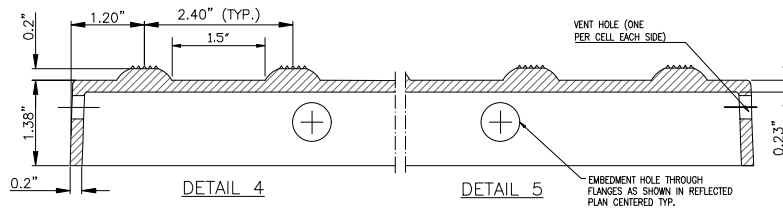

DETAIL 4

DETAIL 5

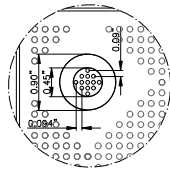

DETAIL 6

Armor-Tile



MATERIAL LIST

#	DESCRIPTION	PART No:	QTY
1	ARMOR-TILE	ADA-C-2436W	1

NOTE: ALL DIMENSIONS ARE NOMINAL WITH A TOLERANCE OF ±0.05

No:	DATE	REVISION	APPR.

SCALE

N.T.S.

DESIGNED	K.S.	
DRAWN	M.T.	
DRAWN	M.T.	07/15/2024

DETECTABLE WARNING SURFACE ADA-C-2436W

FIBERGLASS REINFORCED POLYMER COMPOSITE

Armor-Tile™ ADA

Armor-Tile™

DETECTABLE/TACTILE WARNING SURFACE TILE 24"x36" CAST IN PLACE INLINE DOME TACTILE TILE PLANS AND DETAILS

ADA-C-2436W

01

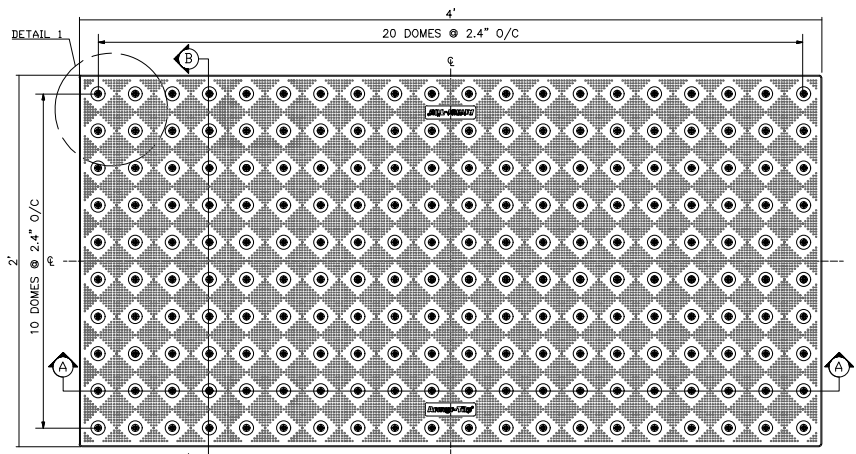

TOP PLAN VIEW

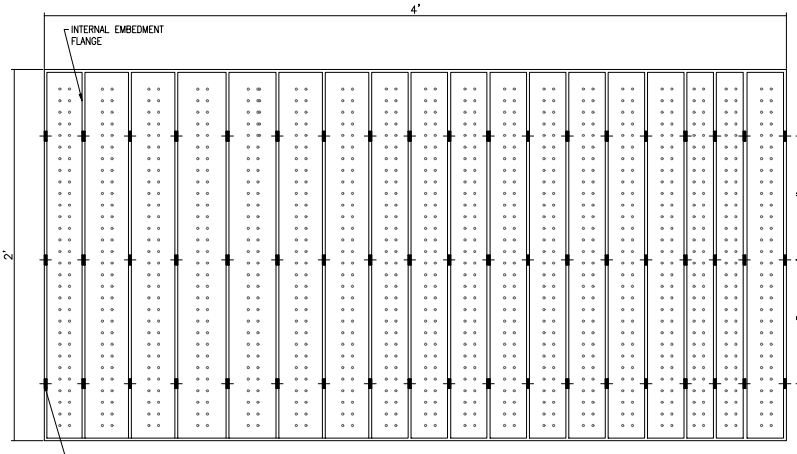

BOTTOM VIEW

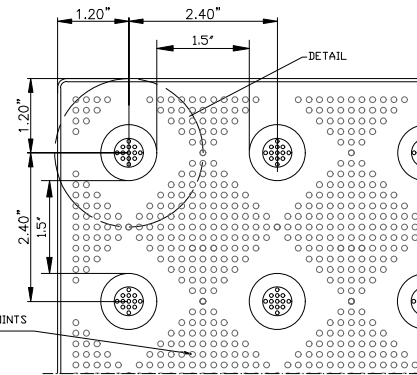

DETAIL 1

NOTE: FIELD LEVEL MICRO-TEXTURE 36 POINTS PER SQUARE INCH

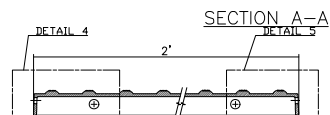
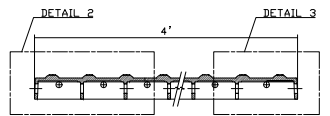

SECTION B-B

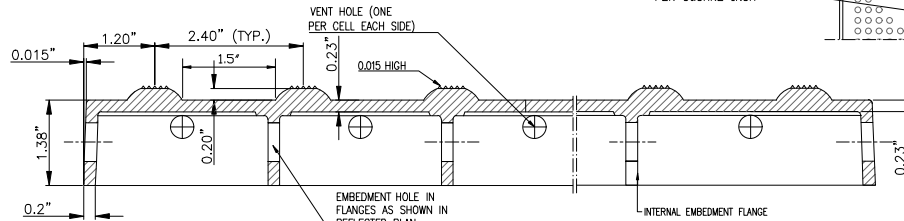

DETAIL 2

DETAIL 3

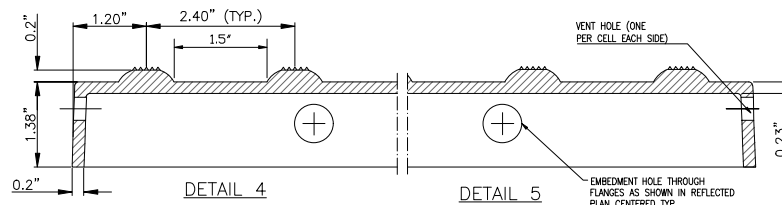

DETAIL 4

DETAIL 5

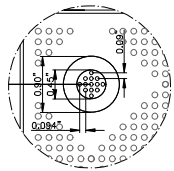

DETAIL 6

Armor-Tile



MATERIAL LIST

#	DESCRIPTION	PART No:	QTY
1	ARMOR-TILE	ADA-C-2448W	1

NOTE: ALL DIMENSIONS ARE NOMINAL WITH A TOLERANCE OF ±0.05

No:	DATE	REVISION	APPR.

SCALE

N.T.S.

DESIGNED	K.S.	
DRAWN	M.T.	
DRAWN	M.T.	07/15/2024

DETECTABLE WARNING SURFACE ADA-C-2448W

FIBERGLASS REINFORCED POLYMER COMPOSITE

Armor-Tile™ ADA

Armor-Tile™

DETECTABLE/TACTILE WARNING SURFACE TILE 24"x48" CAST IN PLACE INLINE DOME TACTILE TILE PLANS AND DETAILS

ADA-C-2448W

01

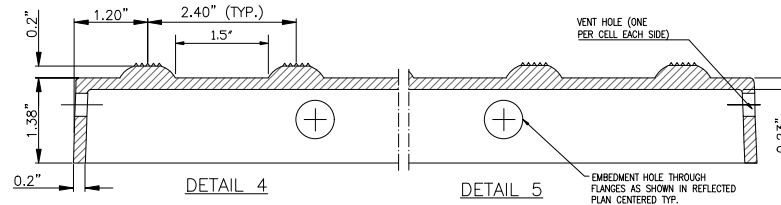
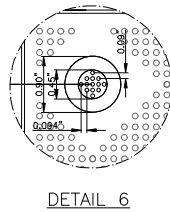
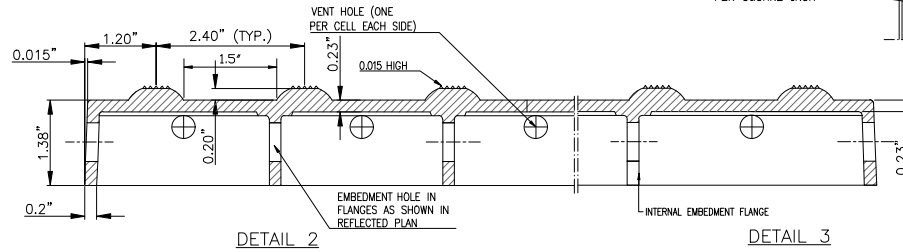
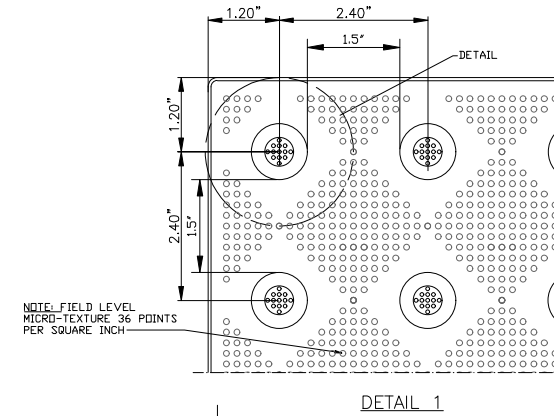
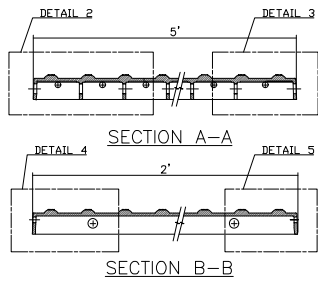
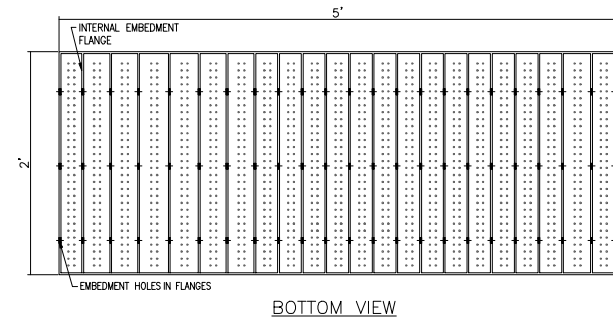
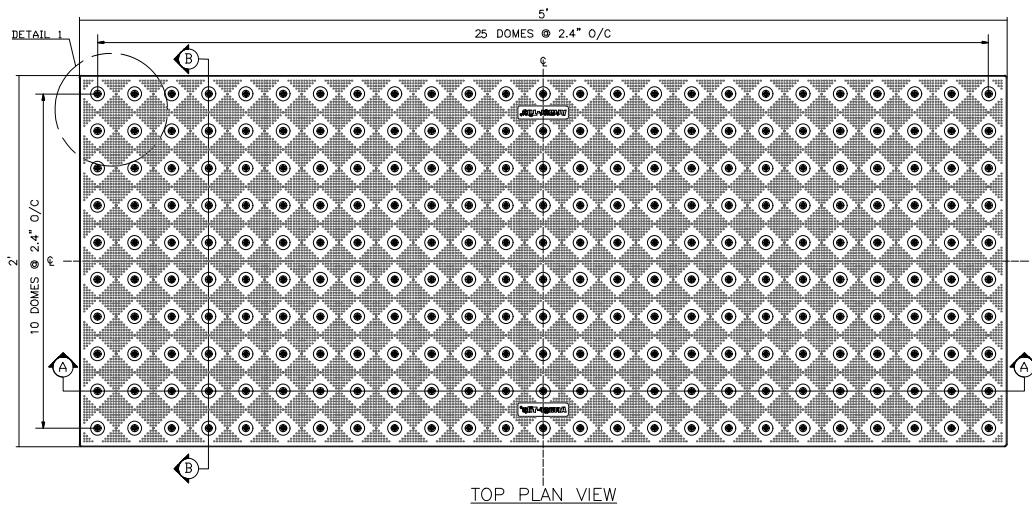

Armor-Tile



MATERIAL LIST

#	DESCRIPTION	PART No:	QTY
1	ARMOR-TILE	ADA-C-2460W	1

NOTE: ALL DIMENSIONS ARE NOMINAL WITH A TOLERANCE OF ±0.05

No:	DATE	REVISION	APPR.

SCALE

N.T.S.

DESIGNED	K.S.	
DRAWN	M.T.	
DRAWN	M.T.	07/15/2024

DETECTABLE WARNING SURFACE ADA-C-2460W

FIBERGLASS REINFORCED POLYMER COMPOSITE

Armor-Tile™ ADA

Armor-Tile™

DETECTABLE/TACTILE WARNING SURFACE TILE 24"x60" CAST IN PLACE INLINE DOME TACTILE TILE PLANS AND DETAILS

ADA-C-2460W

01

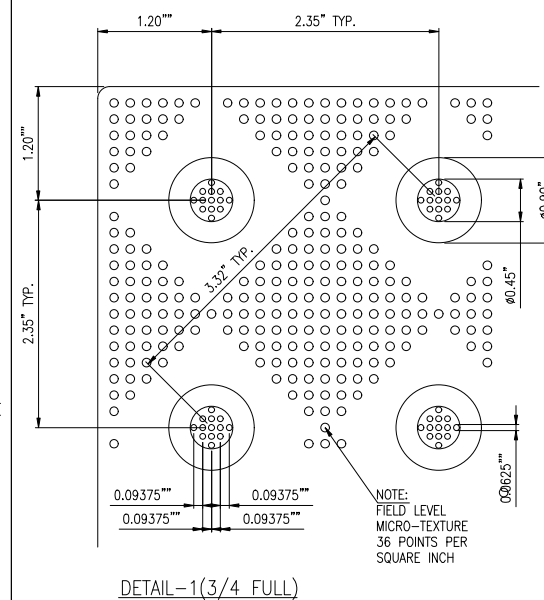
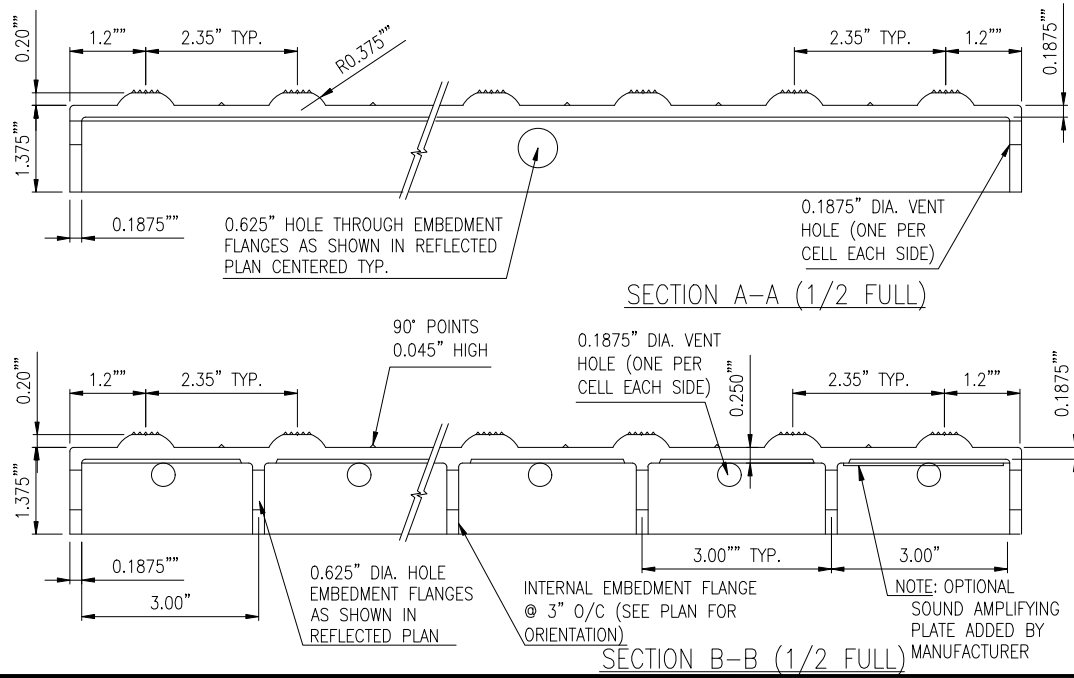
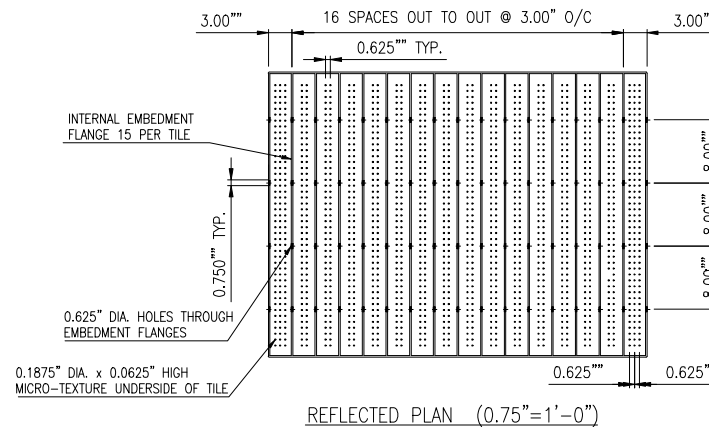
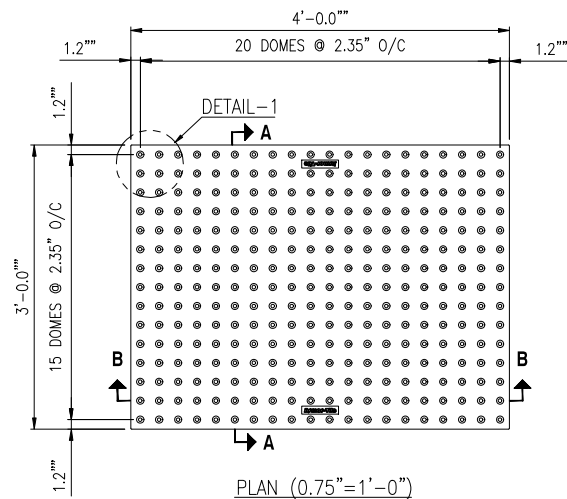

MATERIAL LIST

#	DESCRIPTION	PART No:	QTY
1	ARMOR-TILE	ADA-C-3648W**	1

** COLOR CODE
YELLOW (YW), RED (RD), BLACK (BK),
DARK GRAY (DG), LIGHT GRAY (LG),
WHITE (WH), OCHRE YELLOW (OC),
BLUE (BL), COLONIAL RED (CR)
CUSTOM COLORS AVAILABLE

No:	DATE	REVISION	APPR.
1.	2/27/2013	California Compliance	K.S.

SCALE

DESIGNED	BY	DATE
	K.S.	
DRAWN	BY	DATE
	D.G.	07/15/2024
CHECKED	BY	DATE

PROJECT MANAGER	
TRADE	PART No:
DETECTABLE WARNING SURFACE	ADA-C-3648W**
MATERIAL	
FIBERGLASS REINFORCED POLYMER COMPOSITE	
SUBJECT	
Armor-Tile™ ADA	
SOUND AMPLIFYING DETECTABLE/TACTILE WARNING SURFACE TILE	

PROJECT	
Armor-Tile™	
DETECTABLE/TACTILE WARNING SURFACE TILE	
36" x 48" CAST IN PLACE INLINE DOME TACTILE TILE	
PLANS AND DETAILS	

DRAWING No:	REV. No:
ADA-C-3648W	0

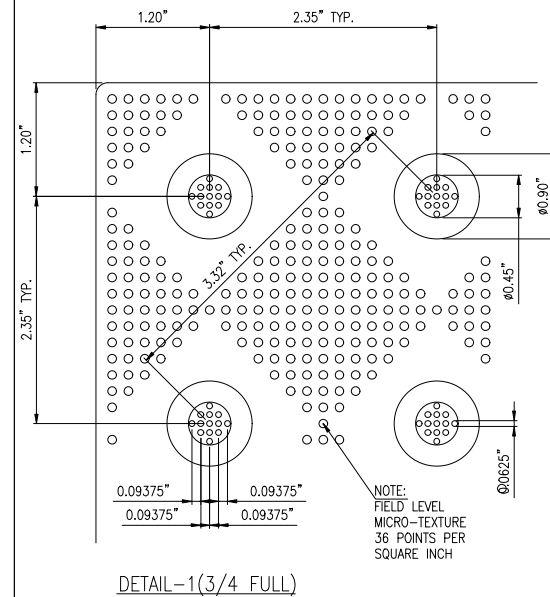
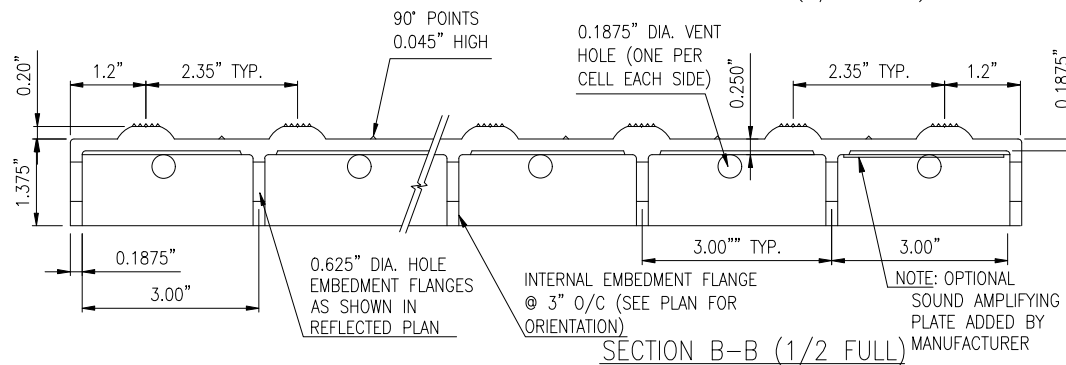
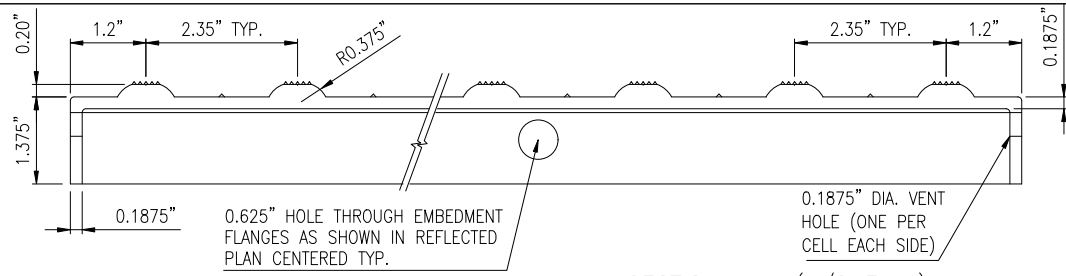
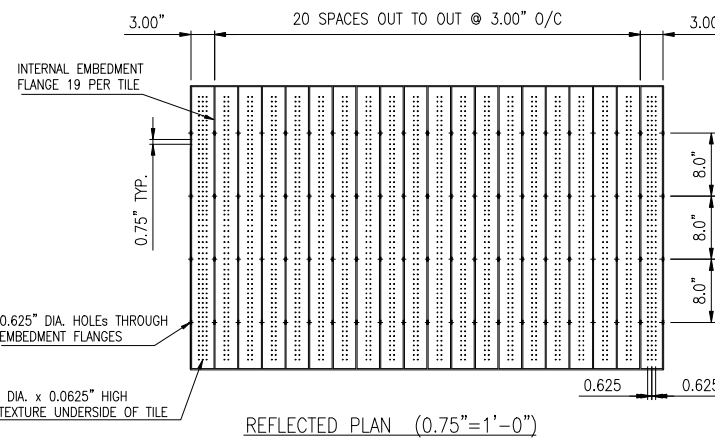
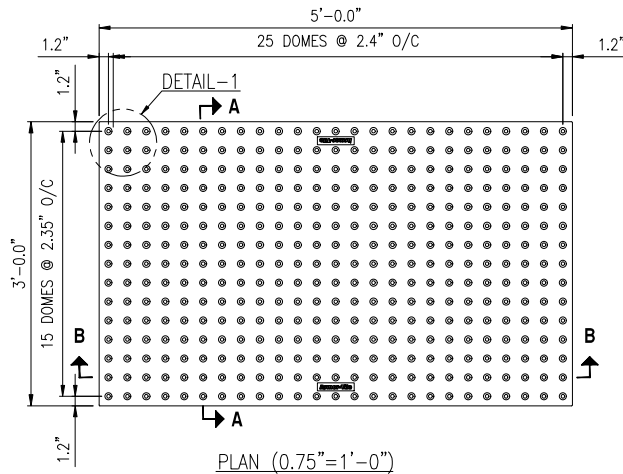

MATERIAL LIST

#	DESCRIPTION	PART No:	QTY
1	ARMOR-TILE	ADA-C-3660W**	1

** COLOR CODE
 YELLOW (YW), RED (RD), BLACK (BK),
 DARK GRAY (DG), LIGHT GRAY (LG),
 WHITE (WH), OCHRE YELLOW (OC),
 BLUE (BL), COLONIAL RED (CR)
 CUSTOM COLORS AVAILABLE

1.	2/27/2013	California Compliance	K.S.
No:	DATE	REVISION	APPR.

SCALE

DESIGNED	BY K.S.	DATE
DRAWN	D.G.	07/15/2024
CHECKED		

PROJECT MANAGER

TRADE	PART No:
DETECTABLE WARNING SURFACE	ADA-C-3660W**

MATERIAL
 FIBERGLASS REINFORCED POLYMER COMPOSITE

SUBJECT
Armor-Tile™ ADA
 SOUND AMPLIFYING DETECTABLE/TACTILE
 WARNING SURFACE TILE

PROJECT

Armor-Tile™
 DETECTABLE/TACTILE
 WARNING SURFACE TILE
 36" x 60" CAST IN PLACE
 INLINE DOME TACTILE TILE
 PLANS AND DETAILS

DRAWING No:	REV. No:
ADA-C-3660W	0

Installation Manual

Armor-Tile Cast In Place

Inline Dome Detectable/Tactile Warning Surface Tile

- A. During Cast In Place Detectable/Tactile Warning Surface Tile installation procedures, ensure adequate safety guidelines are in place and that they are in accordance with the applicable industry and government standards.
- B. The specifications of the structural embedment flange system and related materials shall be in strict accordance with the contract documents and the guidelines set by their respective manufacturers. Not recommended for asphalt applications.
- C. The physical characteristics of the concrete shall be consistent with the contract specifications while maintaining a slump range of 4 - 7 to permit solid placement of the Cast In Place Detectable/Tactile Warning Surface Tile system. An overly wet mix will cause the tile to float. Under these conditions, suitable weights such as 2 concrete blocks or sandbags (25 lb) shall be placed on each tile.
- D. Prior to placement of the Cast In Place Detectable/Tactile Warning Surface Tile system, the contract drawings shall be reviewed.
- E. The concrete pouring and finishing operations require typical mason's tools, however, a 4' long level with electronic slope readout, 25 lb. weights, and a large non-marring rubber mallet are specific to the installation of the Cast In Place Detectable/Tactile Warning Surface Tile system. A vibrating mechanism such as that manufactured by Vibco can be employed, if desired. The vibrating unit should be fixed to a soft base such as wood, at least 1 foot square.
- F. The factory-installed plastic sheeting must remain in place during the entire installation process to prevent the splashing of concrete onto the finished surface of the tile.
- G. When preparing to set the tile, it is important that NO concrete be removed in the area to accept the tile. It is imperative that the installation technique eliminates any air voids under the tile. Holes in the tile perimeter allow air to escape during the installation process. Concrete will flow through the large holes in each embedment flange on the underside of the tile. This will lock the tile solidly into the cured concrete.
- H. The concrete shall be poured and finished true and smooth to the required dimensions and slope prior to the tile placement. Immediately after finishing concrete, the electronic level should be used to check that the required slope is achieved. The tile shall be placed true and square to the curb edge in accordance with the contract drawings. The Cast In Place Detectable/Tactile Warning Surface Tiles shall be tamped (or vibrated) into the fresh concrete to ensure that the field level of the tile is flush to the adjacent concrete surface. The embedment process should not be accomplished by stepping on the tile as this may cause uneven setting which can result in air voids under the tile surface. The contract drawings indicate that the tile field level (base of truncated dome) is flush to adjacent surfaces to permit proper water drainage and eliminate tripping hazards between adjacent finishes.
- I. In cold weather climates it is recommended that the Cast In Place Detectable/Tactile Warning Surface Tiles be set deeper such that the top of domes are level to the adjacent concrete on the top and sides of ramp and that the base of domes to allow water drainage. This installation will reduce the possibility of damage due to snow clearing operations.
- J. Immediately after placement, the tile elevation is to be checked to adjacent concrete. The elevation and slope should be set consistent with contract drawings to permit water drainage to curb as the design dictates.
- K. While concrete is workable, a 3/8" radius edging tool shall be used to create a finished edge of concrete, then a steel trowel shall be used to finish the concrete around the tile's perimeter, flush to the field level of the tile.
- L. During and after the tile installation and the concrete curing stage, it is imperative that there is no walking, leaning or external forces placed on the tile that may rock the tile causing a void between the underside of tile and concrete.
- M. Following tile placement, review installation tolerances to contract drawings and adjust tile before the concrete sets. Two suitable weights of 25 lb each shall be placed on each tile as necessary to ensure solid contact of the underside of tile to concrete.
- N. Following the concrete curing stage, protective plastic wrap is to be removed from the tile surface by cutting the plastic with a sharp knife, tight to the concrete/tile interface. If concrete bled under the plastic, a soft brass wire brush will clean the residue without damage to the tile surface.
- O. If desired, individual tiles can be bolted together using 1/4 inch or equivalent hardware. This can help to ensure that adjacent tiles are flush to each other during the installation process. Tape or caulking can be placed on the underside of the bolted butt joint to ensure that concrete does not rise up between the tiles during installation. Any protective plastic wrap which was peeled back to facilitate bolting or cutting, should be replaced and taped to ensure that the tile surface remains free of concrete during the installation process.
- P. Tiles can be cut to custom sizes, or to make a radius, using a continuous rim diamond blade in a circular saw or mini-grinder. Use of a straightedge to guide the cut is advisable where appropriate.
- Q. Any sound-amplifying plates on the underside of the tile, which are dislodged during handling or cutting, should be replaced and secured with construction adhesive. The air gap created between these plates and the bottom of the tile is important in preserving the detectability properties of the Armor-Tile system as required in various jurisdictions.



Armor-Tile

Tactile Systems

A SureWerx Brand

5 YEAR PRODUCT WARRANTY Fiberglass Reinforced Polymer Composite Products

SureWerx warrants to the Project Owner that the Armor-Tile Tactile Walking Surface Indicator products supplied by SureWerx are free from defects in material including deformation, breakage, and delamination for a period of Five (05) years from the date of substantial completion of the project.

EXCLUSIVE REMEDIES: SureWerx, at its cost, will repair or replace defective material promptly reported to SureWerx during the warranty period. This warranty includes labor costs and cost of removal of the product. Repair or replacement will be done on site.

WARRANTY LIMITATIONS: The warranty of Armor-Tile products does not apply to conditions resulting from improper installation, improper use, external causes, intentional misuse, or abuse, neglected or improper annual maintenance, vandalism, modifications to the Armor-Tile products or installation procedures with the exception of the Owner's right to immediately eliminate an unsafe condition.

DISCLAIMER OF WARRANTY: The above warranties are the Owner's exclusive warranties. No other warranty, express or implied, shall apply. SureWerx specifically makes no warranty of merchantability and/or fitness for a particular purpose. In no event shall SureWerx be liable for any damages, lost profits, direct, consequential, or economic damages.

Issued Date: 00/00/2024

Effective Date: 00/00/2024

Project: Name/Identifier

Issued to: Contractor Name
Address
City, ST 00000

Owner: Owner Name
Address
City, ST 00000

Manufacturer: **SureWerx (Armor-Tile, a SureWerx Brand)**
Product: Detectable Warning Panels, Brick Red Fiberglass
Description: reinforced polymer composite material

Issued by:

John Stieby

Name

Director of End User Sales

Title

00/00/2024

Date

Armor-Tile

Tactile Systems

CLEANING AND MAINTENANCE MANUAL

The Armor-Tile Detectable Tile is unique in its visual and tactile properties and requires a slight variation in cleaning procedures. Due to the undulation and texture of the tile surface, it is necessary to reach the grime that rests on the low parts of the tile. Standard wet mopping will not be completely effective in cleaning these textured surfaces. A major benefit of the vitrified polymer composite tile is that the composition is virtually non-porous, and prevents liquids, dust and grime seeping into the body of the tile. The unique, non-porous nature of the tile therefore lends itself to regular and frequent cleaning in order to maintain and enhance the visual contrast that the bright yellow tile provides. Visual contrast is an essential safety feature of the tactile tiles, and this contrast must be rigorously maintained with regular cleaning in order to provide the contrast that the visually impaired rely on for their safety. The use of general purpose commercial floor cleaners or machine bristle scrubbing will not harm Armor-Tile. However, as these cleaning practices may weaken or dissolve the adjacent floor finish, careful attention must be paid to the selection and application of the cleaning solution. It is advisable to check with the manufacturer of the cleaning solution in order to be certain that the product intended to be used will not harm the Armor-Tile, grout, or the adjacent floor finish in any way.

Regular Maintenance

Many neutral general purpose cleaners are effective for the regular maintenance and cleaning of Armor-Tile. It is important that the cleaner to be used has a non-oil, non-animal fat, non-soap base. Cleaners with these bases may cause problems due to oil-residues which tend to trap dirt in the cleaning process.

Please remember to treat any cleaning product you wish to use on a small, out of the way test area of the tactile surface and adjacent floor area before applying it to the entire Armor-Tile surface. This will ensure that it performs as desired, not only on the Armor-Tile surface but also on the adjacent floor finish, thus avoiding unexpected problems.

Avoid Surface Coatings

Armor-Tile does not require the use of sealants or waxes. Adding surface coatings increases the number of unnecessary steps in maintenance procedures without improving either the appearance of the tile, or the resistance to dirt build-up. In fact, using a surface coating turns a low maintenance vitrified polymer composite finish into a high maintenance tile.

In addition, surface coatings will actually diminish the unique performance characteristics that make Armor-Tile exceptional among tactile tiles. Such surface coatings create a thin barrier that may modify the skid resistance and visibility properties, thereby reducing an important safety feature of the flooring.





325 Corporate Drive
Elgin, IL 60123
USA

US Customer Service
Tel: 1-844-697-2920 | Fax: 1-833-652-1547
Email: orders.ci.usa@surewerx.com

www.surewerx.com