

METALWORKS™ Blades – Classics™

Assembly and Installation Instructions

1. GENERAL

1.1 Product Description

METALWORKS Blades – Classics vertical panels are made from aluminum, designed to be suspended from a Prelude® XL® or Prelude 360° Painted 15/16" suspension system. METALWORKS Blades – Classics are available in fifteen variations to provide design flexibility for discontinuous or continuous ceiling systems. View the chart on the last page to see the various product offerings.

Alignment devices are available so multiple vertical panels can be joined together. Panels can be cut in the field to allow for design freedom. For safety and aesthetic reasons, the field-cut end of the panel must be covered utilizing the field-cut end cap. To minimize labor, custom length blades can be ordered with factory-applied end caps. Contact ASQuote@armstrongceilings.com for more information.

METALWORKS Blades – Classics panels are made of 0.032" aluminum with factory-applied polyester paint available in White, Silver Grey, Gun Metal Grey, Effects™ Wood Looks finishes, and a wide range of custom colors.

Round diagonal perforated options with a plain border, acoustical fleece backing, and acoustical infill are available. The vertical panels are installed using the METALWORKS Blades – Classics Attachment Clip, available in either Stainless Steel or Black Oxide.

For seismic installations refer to section 9.0.

1.2 Storage and Handling

METALWORKS Blades – Classics should be stored in a dry interior location and shall remain in their original crate prior to installation to avoid damage. When removed for install, the vertical panels should be stored in a flat, horizontal position. Proper care should be taken when handling the vertical panels to avoid damage and soiling.

NOTE: METALWORKS Blades – Classics are wrapped with a plastic protective film that is to remain on the product until installation.

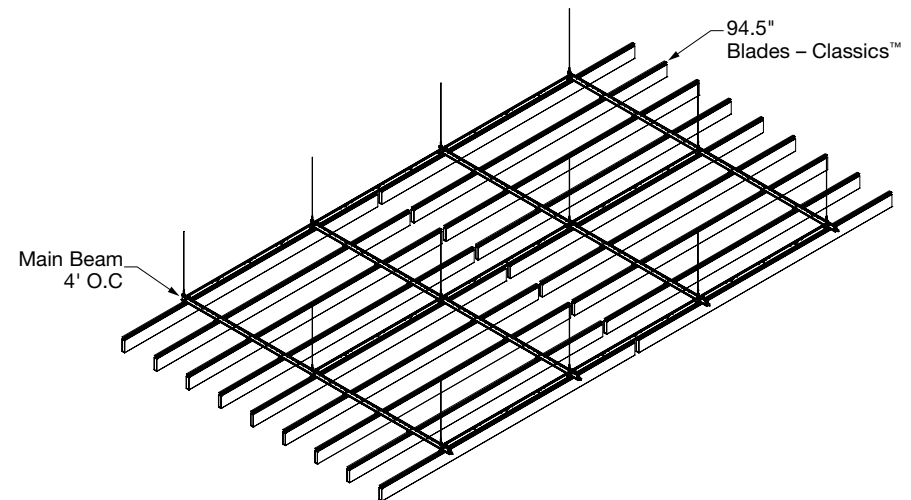

(Fig 1)

1.3 Site Conditions

Areas to receive ceilings shall be free of construction dust and debris. Vertical panels should only be installed in closed and acclimatized buildings. This product is not intended for exterior purposes. Interior systems cannot be used where standing water is present or where moisture will come in direct contact with the ceiling.

1.4 METALWORKS Blades – Classics Layout

METALWORKS Blades – Classics panels are available in a variety of lengths and are able to be attached to either main beams or cross tees. Each vertical panel must be supported by two attachment clips. Specific spacing guidelines are spelled out in section 7.0. Products with end caps create a clean visual with an edge-to-edge minimum gap of 1/4". Blades – Classics without end caps are designed to create a wall-to-wall visual with no gaps using the Alignment Device.

NOTE: The Alignment Device will limit accessibility of the panels.

Based on four standard grid layouts, many METALWORKS Blades – Classics designs can be created. Additional design options are available in the Design Guide.

1.5 Fire Performance

METALWORKS Blades – Classics panels may obstruct or skew the existing or planned fire sprinkler water distribution pattern, or possibly delay the activation of the fire sprinkler or fire detection system. Designers and installers are advised to consult a fire production engineer, NFPA 13, and their local code officials for guidance on the proper installation techniques where fire detection or suppression systems are present.

1.6 Safety Considerations

This product arrives in a crate. Please make arrangement for safe handling. METALWORKS Blades – Classics greater than 94" require two people to install and align each vertical panel safely.

Edges of metal parts can be sharp. Handle metal carefully to avoid injury. Always wear safety glasses and cut-resistant gloves when handling or cutting metal.

When cutting blades, exposed raw edges of metal can be a safety hazard. The end cap is designed to give a finished edge appearance, however deburring/sanding might be required based on the quality of the cut for proper fit. Cutting tools should be appropriate for aluminum. See specific guidance in section 7.6. Improper cutting equipment could damage or dent the metal panels and cause rivets to fail.

1.7 Warranty

The METALWORKS Blades – Classics system has been tested based on the installation method described in this document. Warranty will be voided if you do not follow these instructions and guidelines.

1.8 HVAC Design and Operation & Temperature and Humidity Control

Proper design for both supply air and return air, maintenance of the HVAC filters, and building interior space are essential to minimize soiling. Before starting the HVAC system, make sure supply air is properly filtered and the building interior is free of construction dust. Interior systems cannot be used where standing water is present or where moisture will come in direct contact with the ceiling.

1.9 Plenum

Since METALWORKS Blades – Classics panels are installed from below, they require minimal clearance above the suspension system. The panels do not need to travel into the plenum space during installation or removal.

1.10 Cleaning

An abrasive or strong chemical detergent should not be used. A mild detergent diluted in warm water, applied with a soft cloth, rinsed, and wiped off with a chamois will maintain the panels in good condition. Oily or stubborn stains, if not removed by washing, can be wiped with products like Fantastik®, but care is necessary to avoid affecting the gloss level of the paint finish.

2. DESIGN AND INSTALLATION CONSIDERATIONS

2.1 Directionality

METALWORKS Blades – Classics can be installed in any direction, including parallel, perpendicular, or on any angle from the main beams.

2.2 Sprinklers

METALWORKS Blades – Classics may obstruct or skew the existing or planned fire sprinkler water distribution pattern, or possibly delay the activation of the fire sprinkler or fire detection system. Designers and installers are advised to consult a fire protection engineer, NFPA 13, and their local codes for guidance on the proper installation techniques where fire detection or suppression systems are present.

METALWORKS Blades – Classics hang either 4-7/8" or 6-7/8" below the face of the grid, depending on the depth of your Blade. Sprinkler heads may need to clear the bottom of the panels depending on the openness of the layout. See local building code official or fire protection engineer.

2.3 Plenum

Since METALWORKS Blades – Classics panels are installed from below, they require minimal clearance above the suspension system. The panels do not need to travel into the plenum space during installation or removal.

2.4 Approximate System Weight (lbs/SF) and Attachment to Deck

Overall system weight will be based on the METALWORKS Blades – Classics panels and grid layout:

- METALWORKS Blades – Classics weigh 0.60 – 0.68 lbs/LF. Based on your layout, you will need to calculate the lbs/SF based on the LF weight.
- The weight of the suspension system ranges between 0.2 – 0.3 lbs/SF based on the grid layout and components used.
- If the METALWORKS Blades – Classics panels are being installed in conjunction with mineral fiber/fiberglass acoustical panels then the weight of the acoustical panels must also be considered for the total system weight.

Hanger connections to structure must follow the manufacturer's instructions and referenced code. Average system weight per square foot will depend on design layout.

2.5 Accessibility

- All METALWORKS Blades – Classics panels with factory-installed end caps can be easily removed for access.
- METALWORKS Blades – Classics without factory-installed end caps are not independently accessible when used with an Alignment Device and are installed with no end-to-end reveal.
- To create access areas, install METALWORKS Blades – Classics with factory-installed end caps. This will allow the METALWORKS Blades – Classics panels to be removed independently. This will require a combination of a panel with one factory-installed end cap to end a continuous row before the access area and a panel with two factory-installed end caps to be accessible (**Fig 2 and 3**).

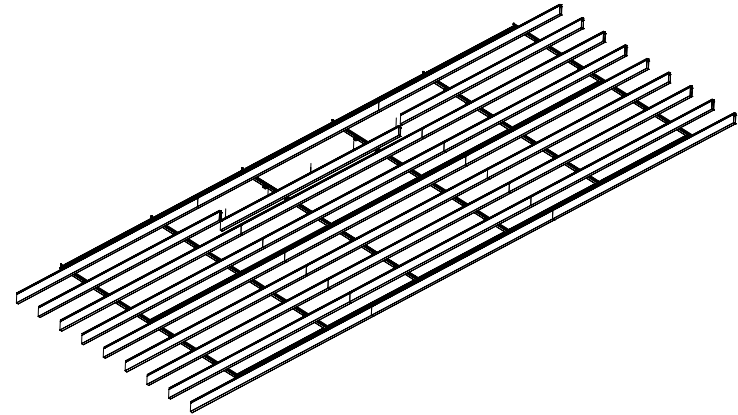

(Fig 2)

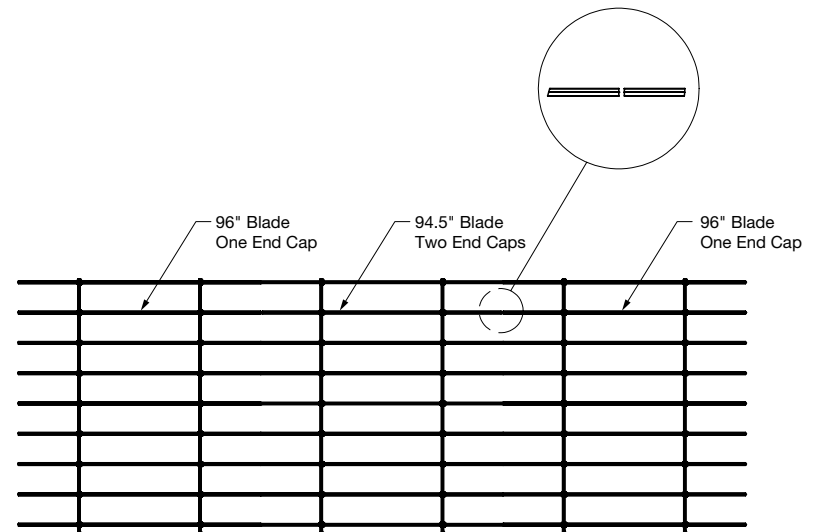

(Fig 3)

2.6 Cutting

Installations can be accomplished with full-size panels utilizing factory-applied end caps or with field-cut panels using the field end caps. To ensure safety and aesthetics of the ceiling system, cut METALWORKS Blades – Classics panels cannot be left exposed and must be used in conjunction with the field-cut end cap. Field end caps will only be effective on 90° straight cuts. They will not fit on mitered or angled cuts. See section 7.6 for more information on how to cut the METALWORKS Blades – Classics panels.

3. ACCESSORIES

3.1 Attachment Clip (Item 7204 __ *)

For a floating ceiling design aesthetic, black 360° Painted Grid is the recommended suspension system to visually disappear into a black plenum. Utilize black oxide METALWORKS Blades – Classics Attachment Clips. Stainless Steel attachment clips are also available (Fig 4). See section 7.2 for Attachment Clip spacing guidelines.

3.2 Alignment Device (Items 7205D41, 7205D61, 7205D62)

For runs of multiple Blades – Classics panels connected end to end, select panels with factory-installed end caps on one end for the first and last panel in the row, and then select panels without end caps to be installed in the interior of the row. Open ends of Blades – Classics are connected using the METALWORKS Alignment Device. The Alignment Device is inserted into the open end of the installed metal panel and pushed against a factory stop. See detail in (Figs 5 & 6).

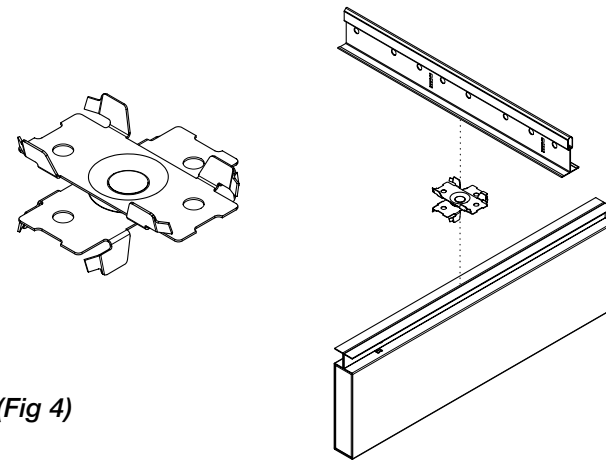

(Fig 4)

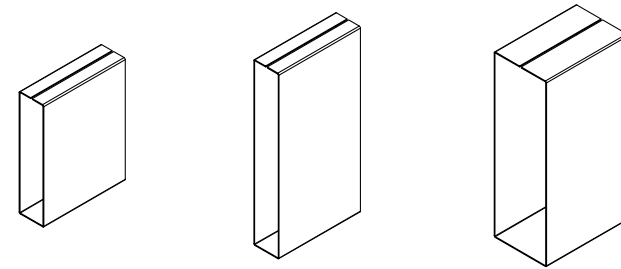

Items 7205D41, 7205D61, 7205D62

(Fig 5)

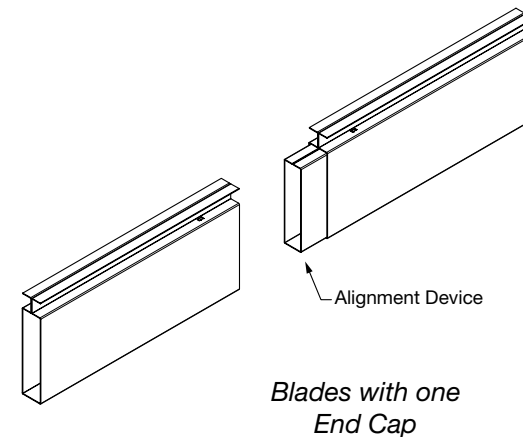

(Fig 6)

3.3 Field-Cut End Cap (Items 8158D41, 8158D61, 8158D62)

The Field-Cut End Cap is available in finishes to coordinate with the METALWORKS Blades – Classics three standard finishes, METALWORKS Effects finishes, and in custom colors. The vertical sides of the end cap when installed cover the unfinished edges and mimics the 1/4" perforation border of the METALWORKS Blades – Classics vertical panels (Figs 7 and 8).

NOTE: The Field-Cut End Cap is a friction fit accessory and will not require glue, rivets, or other fasteners. If either arm of the cap becomes deformed, gently bend to the original pictured shape to ensure friction fit (Fig 9).

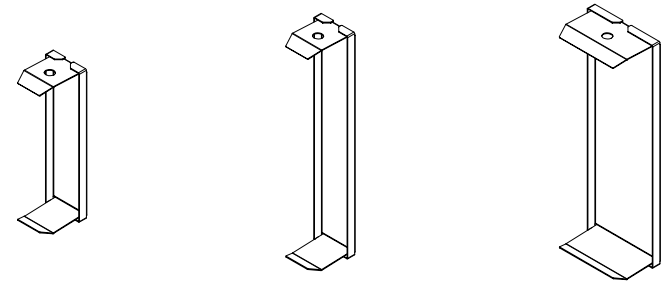

Items 8158D41, 8158D61, 8158D62

(Fig 7)

4. SUSPENSION SYSTEM (WALL-TO-WALL)

The requirements listed here represent the manufacturer's minimum acceptable installation requirements established by the local authority having jurisdiction.

- All installations should follow ASTM C636.
- All references to suspension component duty ratings are per ASTM C636.

4.1 System Components

METALWORKS Blades – Classics can be installed on Intermediate-Duty or Prelude® Heavy-Duty 15/16" suspension systems.

Cross tees must have XL® end details and be at least Intermediate-Duty Equivalent (12 lbs/LF).

New installations that will include mineral fiber or fiberglass acoustical panels in addition to METALWORKS Blades – Classics may require Heavy-Duty main beams and Heavy-Duty Equivalent (HDE) cross tees. This is based on the total system weight and the grid layout (e.g. 1' x 4' vs 4' x 4'). This will allow for attachment to main beams and cross tees.

For alternative layouts, calculate the carrying capacity requirements based on the total system weight to determine if a Heavy-Duty grid system is needed. If total system weight exceeds 3 lbs/SF, Heavy-Duty grid system is needed.

Preferred Design Option: Install with Prelude 360° Painted main beams (730136) and 360° Painted cross tees (XL734036) to minimize grid visibility.

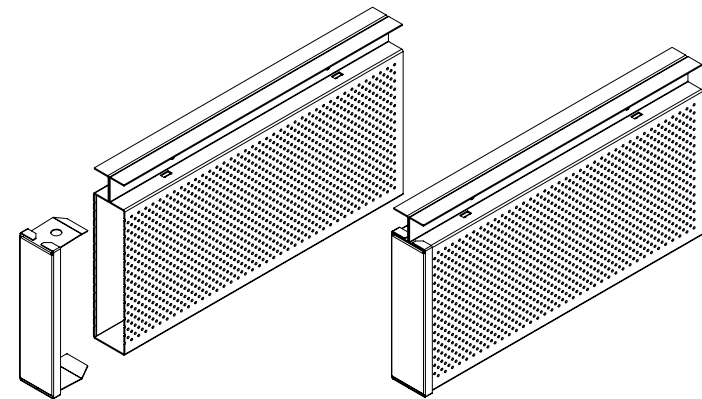

(Fig 8)

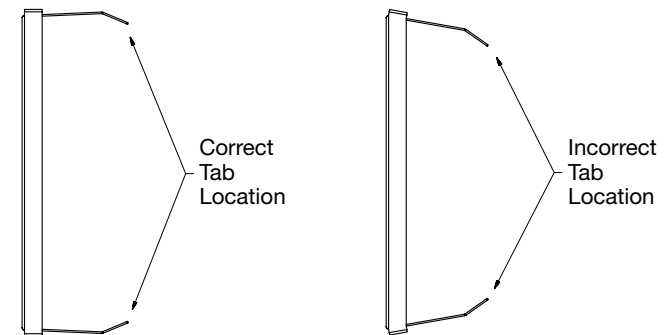

(Fig 9)

Using Existing Grid: METALWORKS Blades – Classics panels can be installed on an existing grid system. This includes systems with mineral fiber and fiberglass acoustical panels in place as long as the following conditions are met:

- Grid must be installed per ASTM C636.
- Grid must be 15/16" Prelude.
- Grid must meet the proper load classification to carry the METALWORKS Blades – Classics (0.5 lbs/LF) and any mineral fiber or fiberglass acoustical panels (if applicable).
- All Attachment Clips must engage main beams only to ensure that the grid carrying the METALWORKS Blades – Classics meets the load carrying requirements. This will allow for Heavy-Duty or Intermediate-Duty main beams to be used. If in a non-seismic area, Heavy-Duty grid must be used when the total system weighs 3 lbs/SF and over. If in a seismic area, Heavy-Duty grid must be used when the total system weighs 2.5 lbs/SF and over.
- Specific instructions regarding placement of Attachment Clips along the panels are noted in section 7.2.

4.2 Suspension Rules for All Layouts

- Main beams must be installed within 24" of the perimeter and then at 48" O.C.
- Hanger wires must be installed within 24" of the perimeter and no more than 48" O.C.
- The ARBRKT or Rigid Attachment Clip (6459BL available in black) can be substituted for hanger wires in up-tight-to-deck installations and must follow the same rules for spacing.

4.3 Layouts

There are four different grid layouts that can be used to support an assortment of visuals for METALWORKS Blades – Classics. Because each METALWORKS Blades – Classics panel requires two clip attachments to the grid, these various layouts will provide different clip location options while minimizing the visibility of the suspension system.

1' x 4' Layout

Main beams installed at 48" O.C. with 4' cross tees perpendicular to the main beams at 12" O.C. (Fig 10)

2' x 2' Layout

Main beams installed at 48" O.C. with 4' cross tees perpendicular to the main beams at 2' O.C. and 2' cross tees spanning the midpoints of the 4' cross tees. (Fig 11)

2' x 4' Layout ("H", bridged)

Main beams installed at 48" O.C. with 4' cross tees perpendicular to the main beams at 48" O.C. and 4' cross tees spanning the midpoints of the 4' cross tees. (Fig 12)

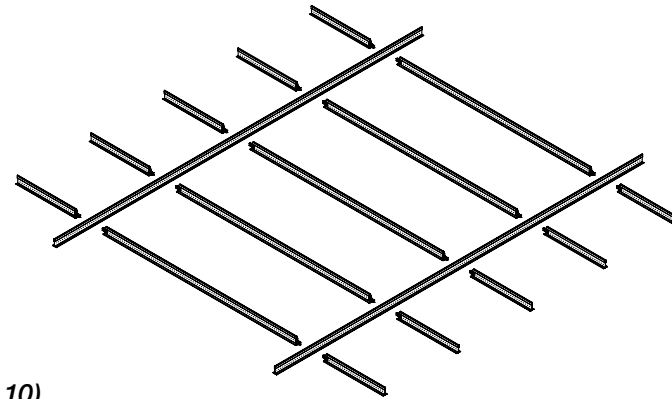

(Fig 10)

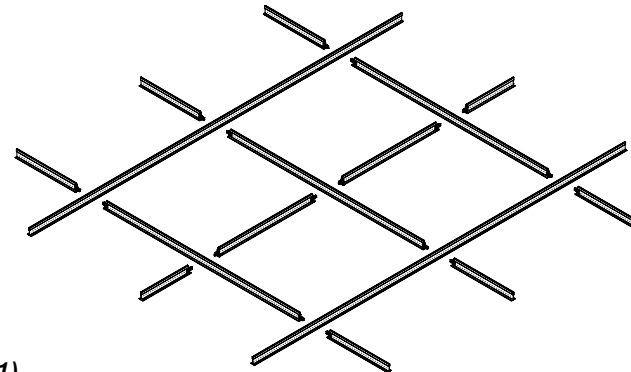

(Fig 11)

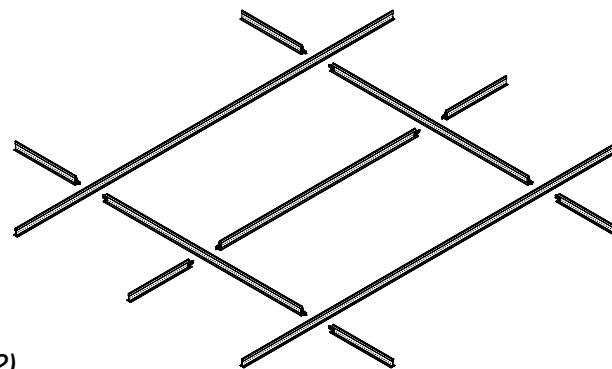

(Fig 12)

4' cross tees must match main beams in load-carrying capacity. Exception for 360° Painted Grid which has Intermediate-Duty Equivalent 4' cross tees (XL734036) and will not be installed with additional acoustical panels.

4' x 4' Layout

Main beams installed at 48" O.C. with 4' cross tees perpendicular to the main beams at 48" O.C. (Fig 13)

4' cross tees must match main beams in load-carrying capacity. Exception for 360° Painted Grid which has Intermediate-Duty Equivalent 4' cross tees (XL734036) and will not be installed with additional acoustical panels.

Wall-to-Wall Perimeter Options

There are no special requirements for wall molding type or installation method.

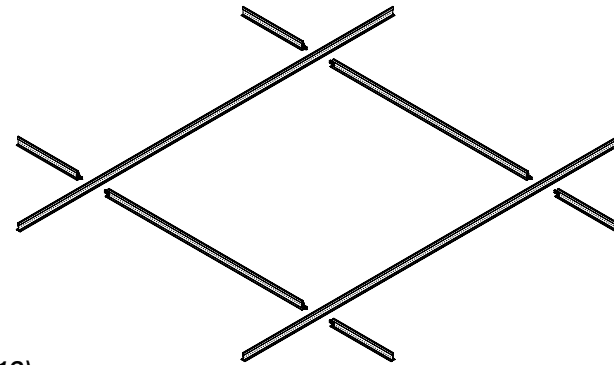

(Fig 13)

5. FLOATING PERIMETER / TRIM FOR DISCONTINUOUS SYSTEMS

METALWORKS Blades – Classics panels hang 4-7/8" or 6-7/8" below the face of the grid system. For discontinuous grid installations, Axiom® trim can be used to provide a professional, finished aesthetic (Fig 14). For panels with an Effects™ Wood Looks finish, Effects trim is also available. Refer to the product specific Axiom installation instructions for guidance on integrating Axiom products.

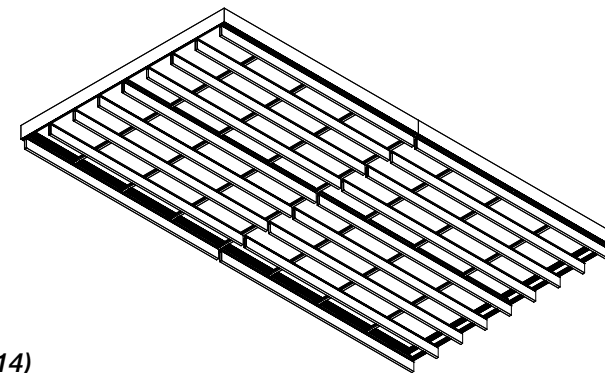

(Fig 14)

6. TRANSITIONS

METALWORKS Blades – Classics can be installed adjacent to other ceiling types or in conjunction with other ceilings. Transitions to a vertical panel installation can be made similarly to any acoustical grid ceiling. The 4-7/8" or 6-7/8" offset of the bottom of the panel to the grid face should be taken into consideration.

7. BLADES – CLASSICS

7.1 Attachment to Grid

7.1.1 METALWORKS Blades – Classics Attachment Clip

METALWORKS Blades – Classics panels are attached to 15/16" Prelude or 360° Painted Grid using METALWORKS Blades – Classics Attachment Clips (Fig 15). Safety gloves are recommended when handling the clips. Each panel requires two Attachment Clips (Item 7204) for installation. Without the use of tools, snap each clip to the upper flange of the METALWORKS Blades – Classics panel by hand, making sure that all four corner tabs of the clip securely snap into place over the flange.

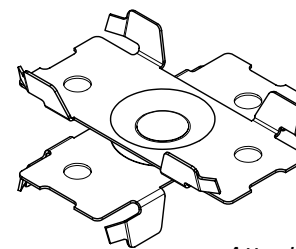

Attachment Clip

(Fig 15)

The top of each Attachment Clip can rotate to align with the grid and is then snapped onto the flange of the main beams or cross tees (Fig 16). For installations using existing grid, all connections must be made to Prelude main beams. Make sure that all four corner tabs of the clip securely snap into place of the grid flange.

7.2 Clip Guidelines

- Clips can be rotated in any orientation.
- Clips can be attached along the length of the METALWORKS Blades – Classics panel as long as they follow the minimum spacing guidelines:

Item Number	Description	Minimum Spacing From Clip to Clip*
8155D41 _ _ _ _	22.5 x 4 x 1" with two factory installed end caps	9.25"
8156D41	46.5 x 4 x 1" with two end caps	23.25"
8157D41	94.5 x 4 x 1" with two end caps	48.25"
7202D41	96 x 4 x 1" with one end cap	49"
7203D41	96 x 4 x 1" with no end caps	49"
8155D61	22.5 x 6 x 1" with two factory installed end caps	9.25"
8156D61	46.5 x 6 x 1" with two end caps	23.25"
8157D61	94.5 x 6 x 1" with two end caps	48.25"
7202D61	96 x 6 x 1" with one end cap	49"
7203D61	96 x 6 x 1" with no end caps	49"
8155D62	22.5 x 6 x 2" with two factory installed end caps	9.25"
8156D62	46.5 x 6 x 2" with two end caps	23.25"
8157D62	94.5 x 6 x 2" with two end caps	48.25"
7202D62	96 x 6 x 2" with one end cap	49"
7203D62	96 x 6 x 2" with no end caps	49"

*Measured from clip's vertical center (Fig 18)

Blade Length	Blade Depth: 4" – 6"	Blade Depth: > 6" – 8"
ATTACHMENT CLIPS NEEDED FOR 1" WIDE BLADES		
12" - 72"	2	2
> 72" - 96"	2	4
ATTACHMENT CLIPS NEEDED FOR 2" WIDE BLADES		
12" - 48"	2	2
> 48" - 72"	2	2
> 72" - 96"	2	4

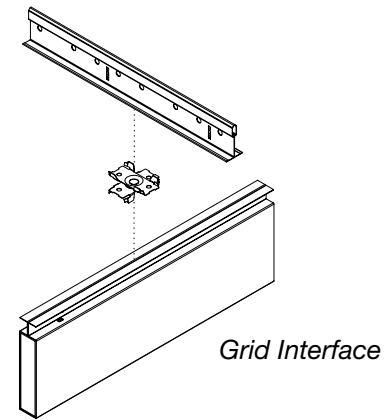

(Fig 16)

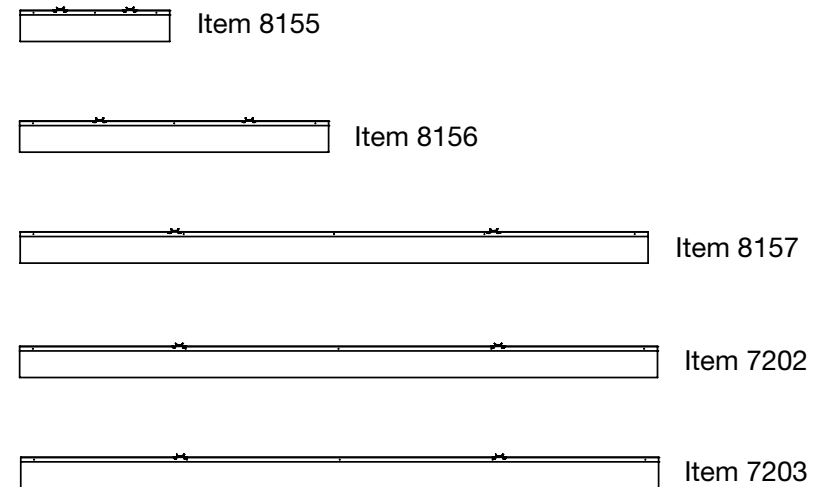

(Fig 17)

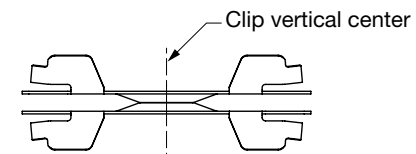

(Fig 18)

- A minimum of one clip is required on each side of the Blade, as defined by the Blade's vertical center.
- Clips cannot be placed in the middle 4" of any sized Blade.
- Clips cannot be placed 0" – 2" from either edge of the Blade to the center of the clip.
- Any clips installed between 2" – 4" from either edge of the Blade to the center of the clip must have a screw inserted through the pilot hole into the panel flange. *(Fig 19)*

NOTE: Seismic installations will require additional screws through the clips into the grid and through the clips into the Blade, regardless of where the clips are positioned on the Blade. See section 9.4 for further information.

7.3 Minimum Blades – Classics Panel-to-Panel / Clip-to-Clip Spacing

Due to the clips overall size, the minimum spacing between two clips is approximately 2-3/16". The spacing between panels will depend on the thickness of the Blades – Classics panels. *(Fig 20)*

7.4 Installing METALWORKS Blades – Classics panels on Grid with Existing Acoustical Ceiling Panels Installed (square lay-in panels only)

- METALWORKS Blades – Classics can only be installed in conjunction with square lay-in panels. Panels that drop below the grid face will interfere with the Attachment Clips.
- See section 4.0 for guidance on installations with METALWORKS Blades – Classics and acoustical ceiling panels.
- Align the top half of the Attachment Clip with the grid and then snap it onto the flange of the grid. Make sure that all four corner tabs of the clip securely snap into place over the grid flange.
- While holding the clip against the grid face, press down on the acoustical panel to ensure that it is level and flush with the flange of the grid. **NOTE:** the clip will pierce the face of the acoustical panel. Facial marring will be hidden by the clip once the METALWORKS Blades – Classics are installed.
- Press each blade up into the Attachment Clips, making sure that all four corner tabs of the clip securely snap into place over the METALWORKS Blades – Classics flange.

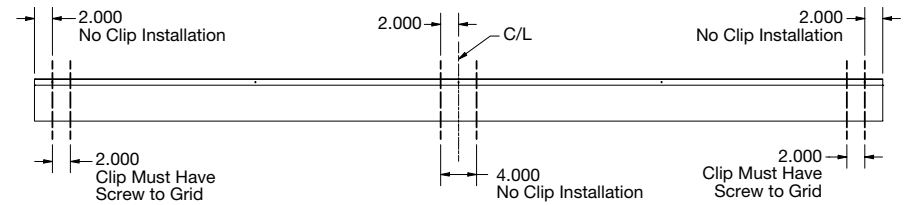

(Fig 19)

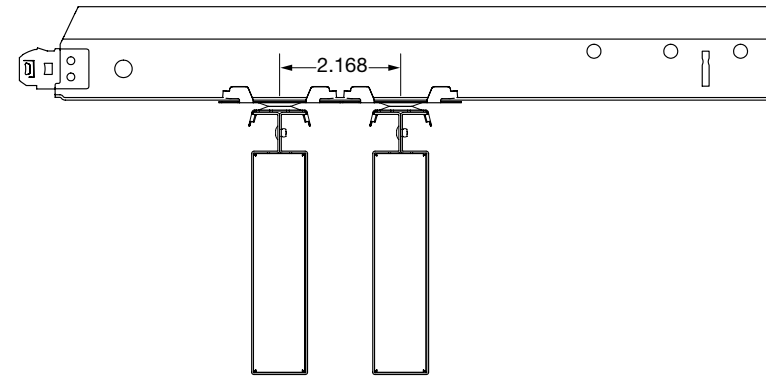

(Fig 20)

7.5 Continuous Runs of METALWORKS Blades – Classics (connected end to end)

For runs of multiple Blades – Classics panels connected end to end, select panels with factory-installed end caps on one end for the first and last panel in the row, and then select panels without end caps to be installed in the interior of the row. Open ends of Blades – Classics are connected using the METALWORKS Alignment Device (items 7205D41, 7205D61, 7205D62). The Alignment Device is inserted into the open end of the installed metal panel and pushed against a factory stop. (Fig 21)

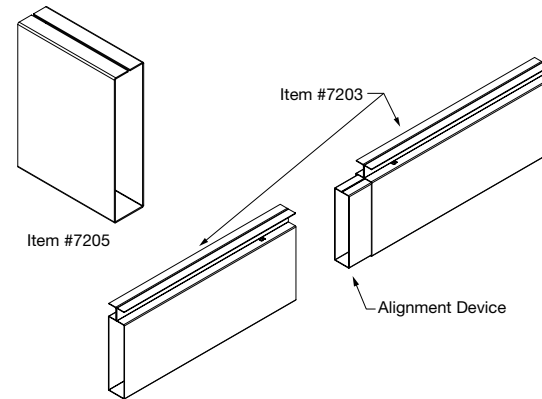

(Fig 21)

7.6 Cutting of Blades – Classics

The Field-Cut End Cap enables METALWORKS Blades – Classics panels to be cut to length and finished onsite. Alternatively, custom length blades can be ordered with factory-applied end caps. Any field-cut ends of the panels must be covered with the Field-Cut End Cap to ensure aesthetic standards and aid in safe handling.

7.6.1 Cutting Guidelines

- METALWORKS Blades – Classics can only be straight cut to length (not at an angle) to be compatible with the Field-Cut End Cap. (Fig 22)
- It is recommended to use a miter saw with a non-ferrous metal cutting blade for thin-walled material. Consult blade manufacturer for specific recommendation.
- If a clean cut is not achieved it may be necessary to deburr the edge for proper fit of the end cap.
- Perforated panels contain an acoustic infill bag. This can be cut through during the blade cut and does not need to be resealed before inserting the Field-Cut End Cap.

7.6.2 Field-Cut End Cap Orientation

- The notch at the top of the Field-Cut End Cap fits around the "T" profile of the panel, allowing for straight cuts with no additional modification. (Fig 23)

7.6.3 Inserting Field-Cut End Cap

- Field-Cut End Caps are friction fit and do not require any adhesive or fasteners.
- Insert the cap into the cut end of the panel with the notch in the proper orientation. (Fig 24)
- Field-Cut End Caps hold the cut end of the panel together, eliminating the need to replace pop rivets through the "T" profile.
- Field-Cut End Caps cover the cut edge while recreating the unperforated border.

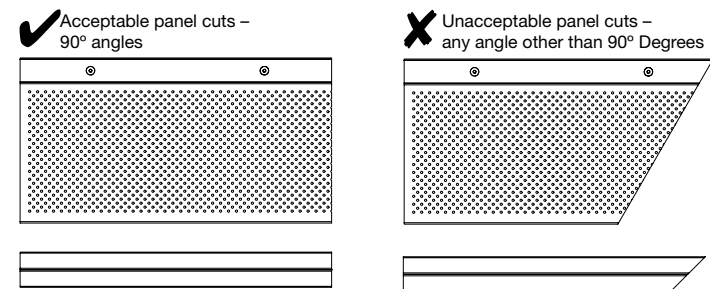

(Fig 22)

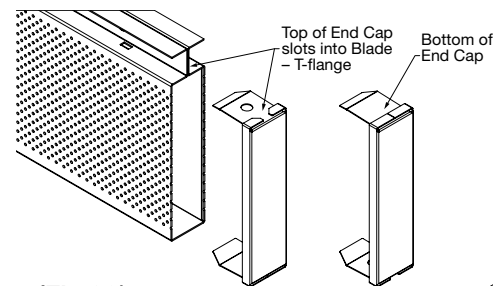

(Fig 23)

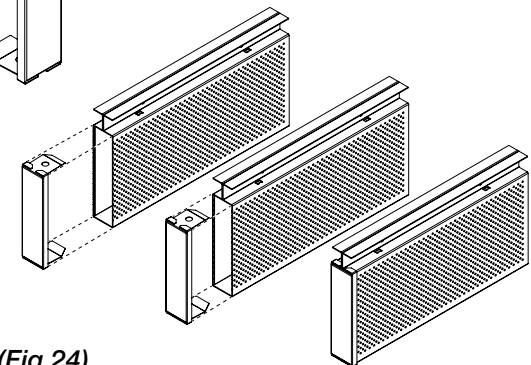

(Fig 24)

7.7 Blades – Classics Panel Face Offset

METALWORKS Blades – Classics panels hang either 4-7/8" or 6-7/8" from the face of the grid depending on the depth of your Blade.
(Fig 25)

7.8 Directionality and color/finish considerations

METALWORKS Blades – Classics can be installed in any direction, including parallel, perpendicular, or on any angle from the main beams.

METALWORKS Blades – Classics are finished with factory-applied polyester paint available in White, Silver Grey, Gun Metal Grey, Effects™ Wood Looks finishes, and a wide range of custom colors.

7.9 Acoustical Infill

M15 Diagonal Round perforated METALWORKS Blades – Classics panels come with factory-installed acoustical infill.

8. SPECIAL INSTALLATION CONSIDERATIONS

8.1 Modification to grid related to MEP such as:

- Slopes: METALWORKS Blades – Classics cannot be installed on a slope.
- Single tee insertion: Grid layouts that include single tee insertion connections should be reinforced with the Single Tee Adapter Clip (STAC), which is referenced in document LA297835.

9. SEISMIC INSTALLATIONS (C AND D, E, F)

9.1 For more details on seismic installations please see our brochure "*Seismic Design: What You Need to Know*".

9.2 Suspension System

All seismic installations of METALWORKS Blades – Classics panels must be installed per seismic design categories D, E, and F. This is regardless of the total system weight. Prelude Heavy-Duty grid is required per ASTM E580 and the cross tees may have to match the mains in load-carrying capacity based on the grid layouts, as defined in section 4.1.

9.3 Seismic Rx Categories D, E, F

- Ceiling installation should conform to basic requirements established in ASTM C636
- Minimum 7/8" wall molding
- Suspension system must be attached on two adjacent walls. Opposite walls require BERC2 with 3/4" clearance.

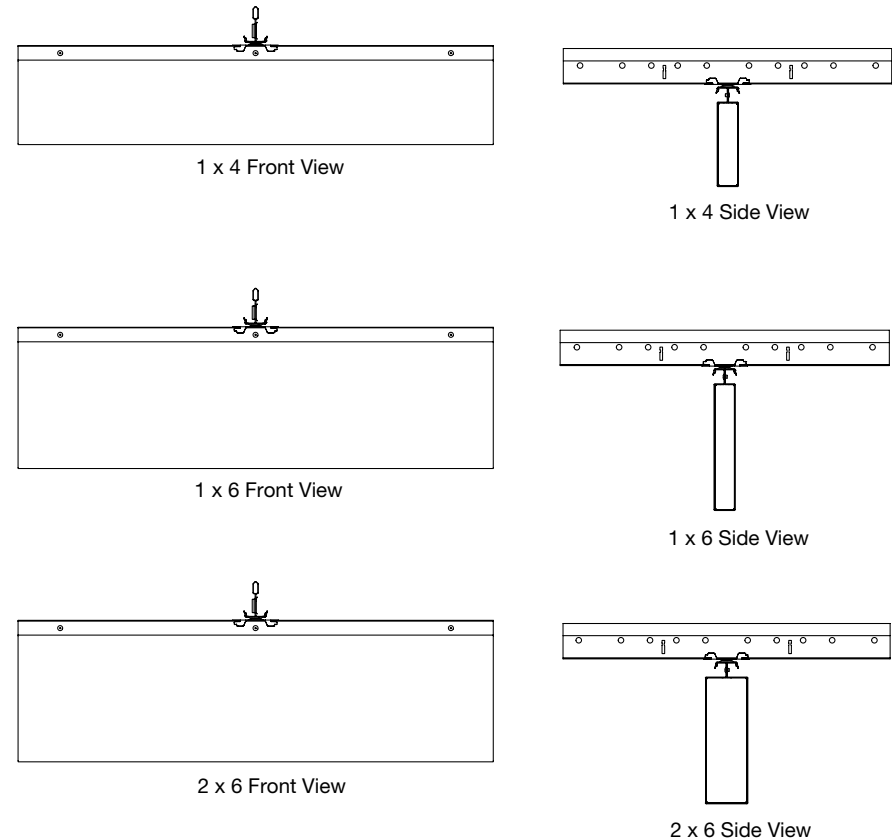

(Fig 25)

- BERC2 maintains main beam and cross tee spacing; no other components are required
- Heavy-Duty systems as identified in ICC-ESR-1308
- Safety wires required on light fixtures
- Perimeter support wires within 8"
- Ceiling areas over 1,000 SF must have horizontal restraint wire or rigid bracing
- Ceiling areas over 2,500 SF must have seismic separation joints or full height partitions
- Ceilings without rigid bracing must have 2" oversized trim rings for sprinklers and other penetrations
- Changes in ceiling plane must have positive bracing
- Cable trays and electrical conduits must be independently supported and braced
- Suspended ceilings will be subject to special inspection
- Suspension layouts are the same as described in section 4.0
- Connection to wall: see BPCS-4141 *Seismic Design: What You Need to Know – Code Requirements Seismic Rx® Tested Solutions – Seismic Rx® Approaches To Category C And D, E, and F Installations*
- Special bracing required: See BPCS-4141 *Seismic Design: What You Need to Know – Code Requirements Seismic Rx® Tested Solutions – Bracing and Restraint for Seismic Installations*
- Seismic separation joints: See BPCS-4141 *Seismic Design: What You Need to Know – Code Requirements Seismic Rx® Tested Solutions – Seismic Separation Joints*

9.4 Blades – Classics Panel Attachment

Minimum spacing between Blades – Classics for Seismic Design Categories D, E, and F is 6" O.C.

Before the Blades – Classics panel is installed, add a low-profile framing screw (1/2" sharp point) screw through the pilot hole on the Attachment Clip into the Blade's flange. This will secure the clip. This must be done to every Attachment Clip. **(Fig 26)**

After installing the Blades – Classics panel (or a run of vertical panels) to the suspension system, ensure correct positioning of the panel and add one screw through the pilot hole on the clip through the face of the grid **(Fig 26)**. This will secure the clip to the suspension system.

NOTE: the use of a long shaft adapter may be necessary to install this screw.

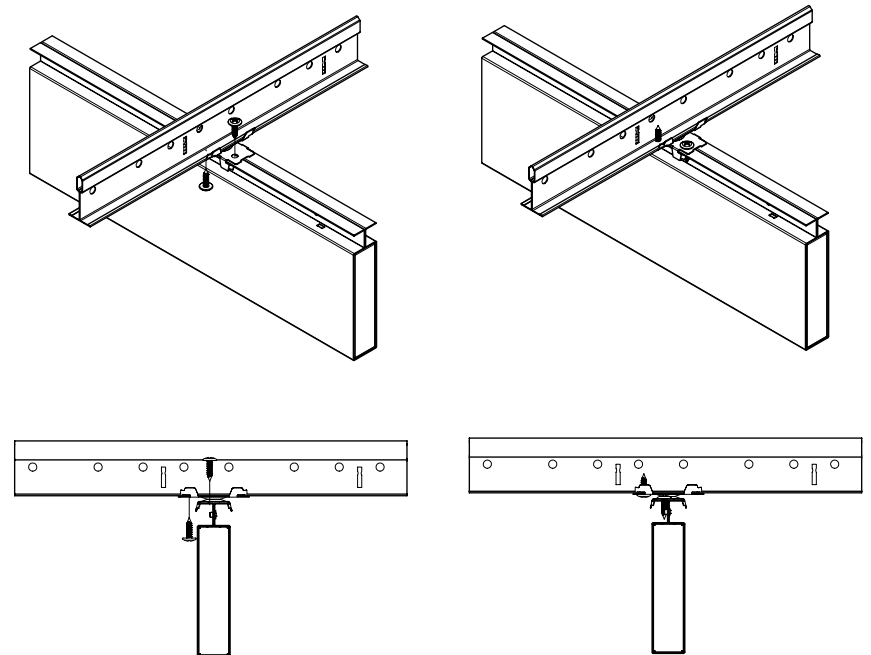

(Fig 26)

METALWORKS™ BLADES – CLASSICS™ ITEMS				
Item #	Item Name	Incl. with Blades – Classics	Sold by the:	Min. Order Qty.
8155D41 8155D61 8155D62	Vertical panel with caps on both ends 22-1/2 x 4 x 1" 22-1/2 x 6 x 1" 22-1/2 x 6 x 2"	—	Pc	20
8156D41 8156D61 8156D62	Vertical panel with caps on both ends 46-1/2 x 4 x 1" 46-1/2 x 6 x 1" 46-1/2 x 6 x 2"	—	Pc	20
8157D41 8157D61 8157D62	Vertical panel with caps on both ends 94-1/2 x 4 x 1" 94-1/2 x 6 x 1" 94-1/2 x 6 x 2"	—	Pc	20
7202D41 7202D61 7202D62	Vertical panel with cap on one end 96 x 4 x 1" 96 x 6 x 1" 96 x 6 x 2"	—	Pc	20
7203D41 7203D61 7203D62	Vertical panel with no end caps 96 x 4 x 1" 96 x 6 x 1" 96 x 6 x 2"	—	Pc	20
METALWORKS BLADES – CLASSICS ACCESSORIES – suspension separate				
7300/7301	Prelude® Main Beam	No	Ctn	20
Various	Prelude® XL® Cross Tee	No	Ctn	60
730136/56418	Prelude 360° Painted Main Beam	No	Ctn	20
Various	Prelude XL 360° Painted Cross Tee	No	Ctn	60
Various	Axiom® Trim (Optional)	No	Pc	—
ACCESSORIES				
7204	Blades – Classics™ Attachment Clip	No	Ctn	100
7205D41 7205D61 7205D62	1" x 4" Alignment Device 1" x 6" Alignment Device 2" x 6" Alignment Device	No	Ctn	24
8158D41 8158D61 8158D62	1" x 4" Field Cut End Cap 1" x 6" Field Cut End Cap 2" x 6" Field Cut End Cap	No	Ctn	10

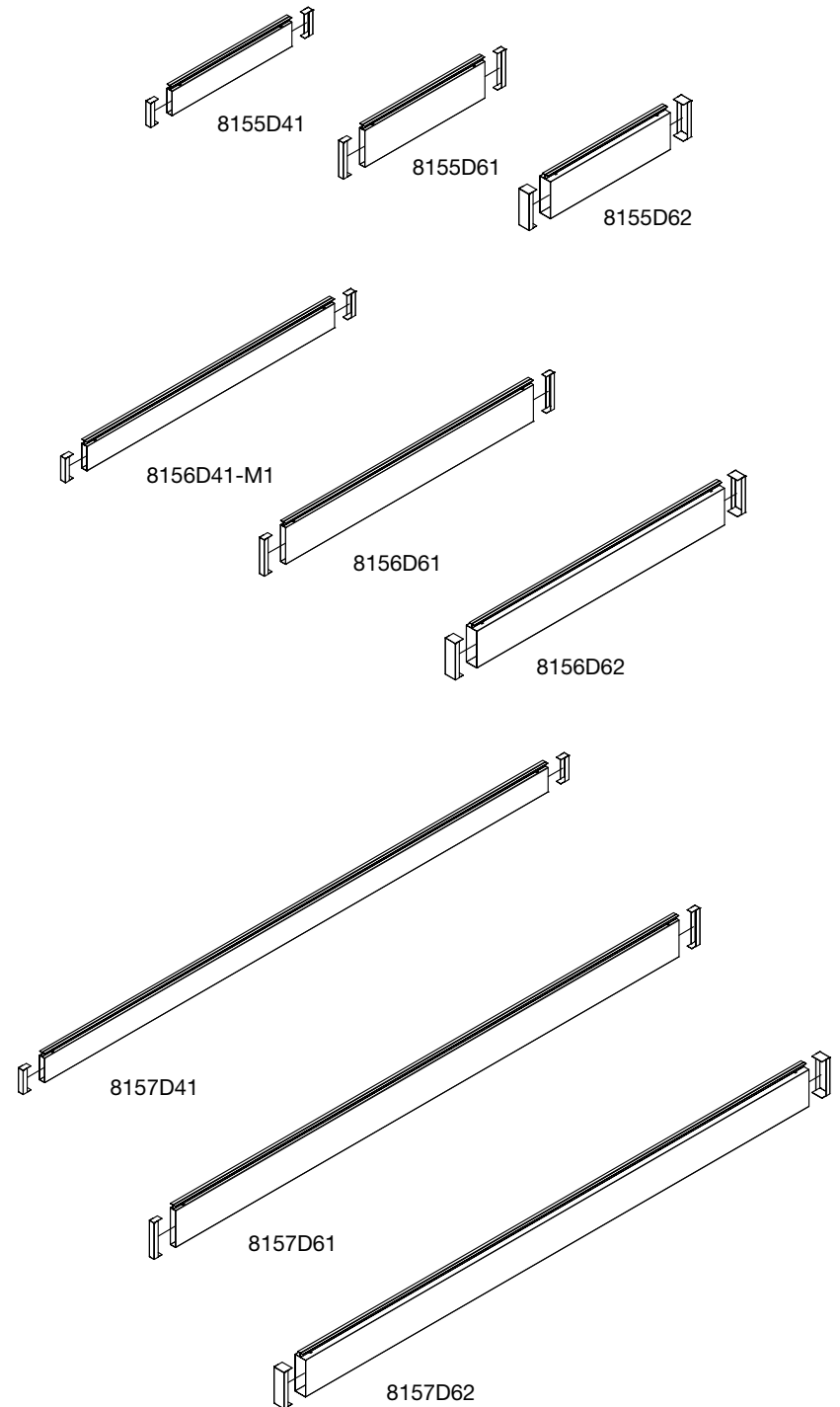

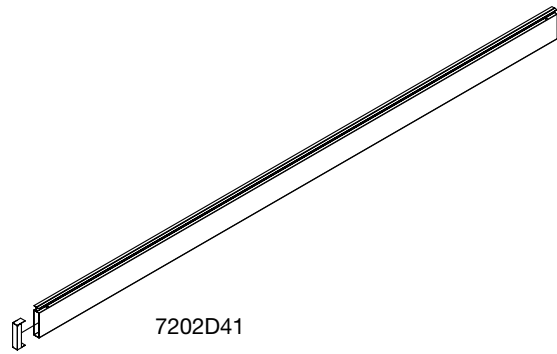

7202D41

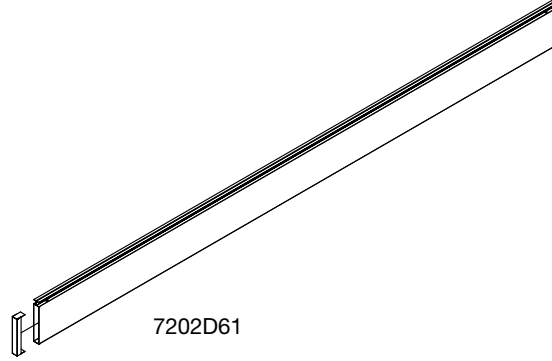

7202D61

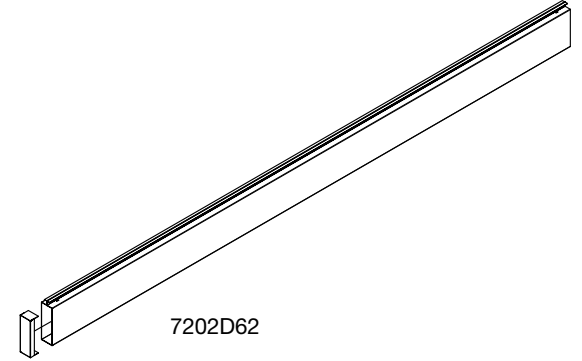

7202D62

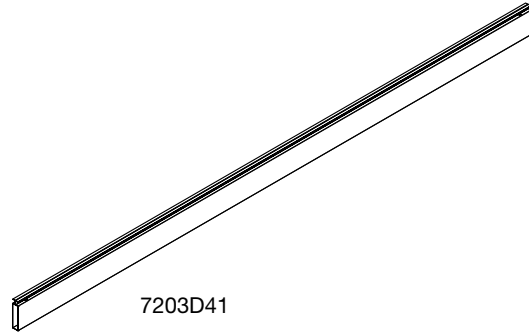

7203D41

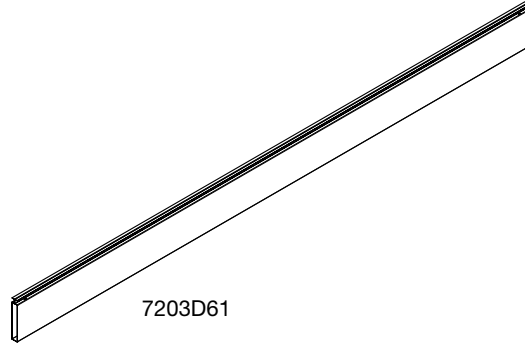

7203D61

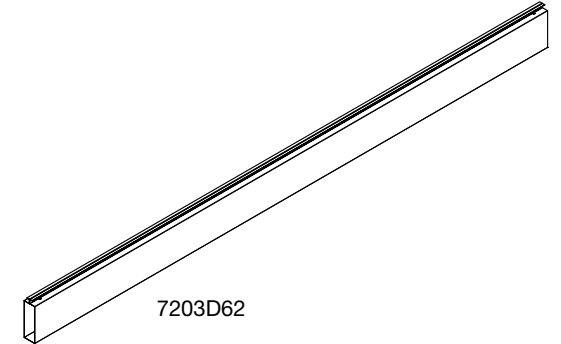

7203D62

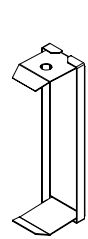

8158D41



8158D61

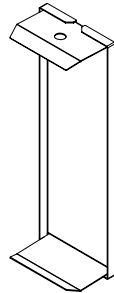

8158D62

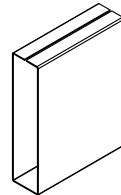

7205D41

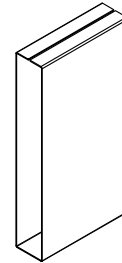

7205D61

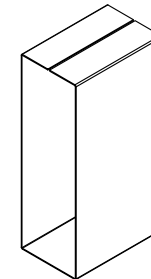

7205D62

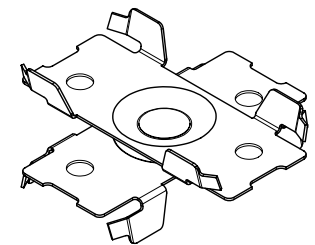

7204

MORE INFORMATION

For more information, or for an Armstrong Ceilings representative, call 1 877 276 7876.

For complete technical information, detail drawings, CAD design assistance, installation information, and many other technical services, call TechLine customer support at 1 877 276 7876 or FAX 1 800 572 TECH.

Inspiring Great Spaces® is a registered trademark of AFI Licensing LLC; Fantastik® is a registered trademark of S. C. JOHNSON & SON, INC.; All other trademarks used herein are the property of AWI Licensing LLC and/or its affiliates.

© 2020 AWI Licensing Company Printed in the United States of America

