



# METAL WORKS™

Blades –  
Classics™

Inspiring Great Spaces®

**Armstrong**®  
CEILING SOLUTIONS

# Create a memorable VISUAL

The durability of metal with design options using standard or custom panel lengths and finishes, limited only by imagination.

- ▶ Acoustics and aesthetics for hundreds of creative layouts
- ▶ Blades panel lengths range from 22" to 96"
- ▶ Nine standard colors, including six Effects™ Wood Looks finishes
- ▶ Custom RAL® colors available on non-perforated panels
- ▶ Installs on standard Prelude® XL® 15/16" or 360° Painted suspension system
- ▶ New panel lengths and caps minimize cuts and waste

## More Options = More Designs

MetalWorks™ Blades – Classics™ ▶  
in Effects™ Cherry





▲ MetalWorks™ Blades – Classics™, Divergent Layout; Tectum® Panel Art Wall Panels



# Classic Doesn't Mean ORDINARY.

Express a new narrative with MetalWorks™ Blades – Classics™ linear panels. From divergent drama to striated stories; from sunflowers to sunbursts. Create a look to visually tell your tale with the classic product that will spark your imagination. Turn the page for layouts that will inspire your linear prose.

# METALWORKS™ Blades – Classics™

## 1 x 4 Grid Layouts

---

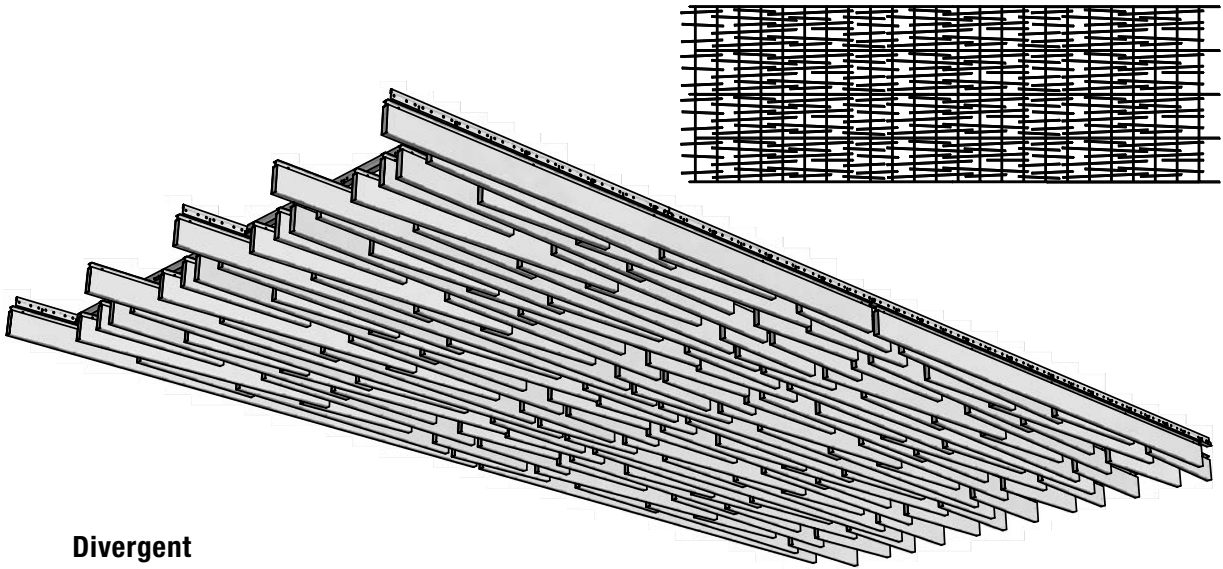
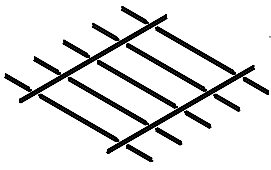

**Divergent**

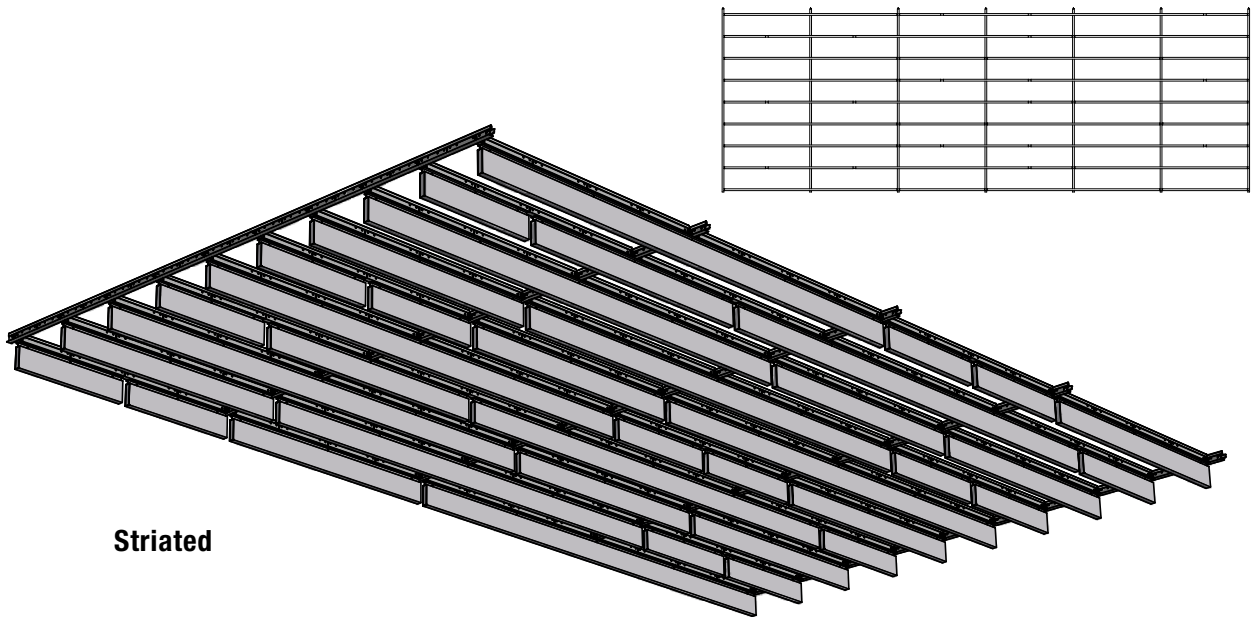

**Striated**

# METALWORKS™ Blades – Classics™

## 1 x 4 Grid Layouts

---

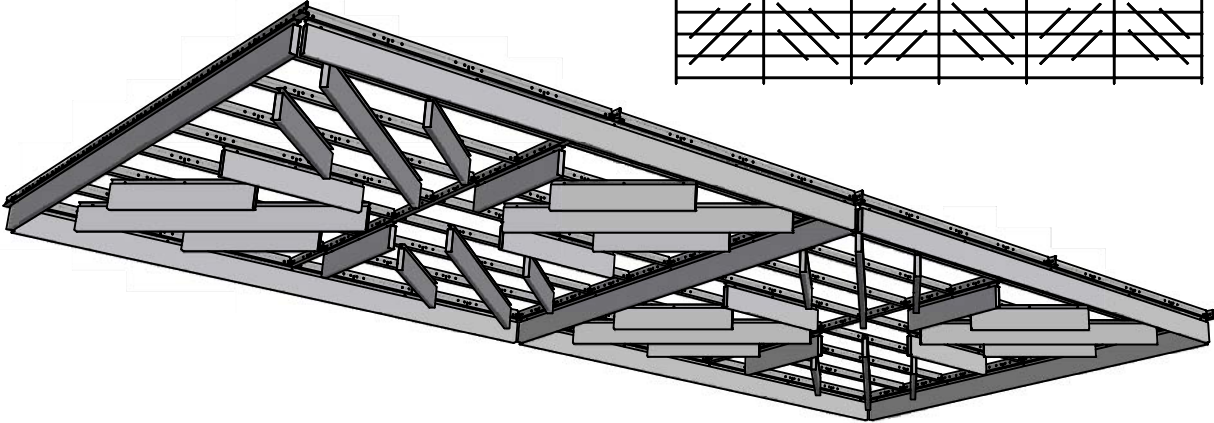
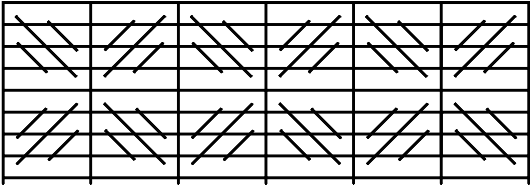
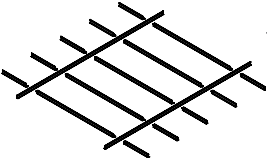

**SunFlower**

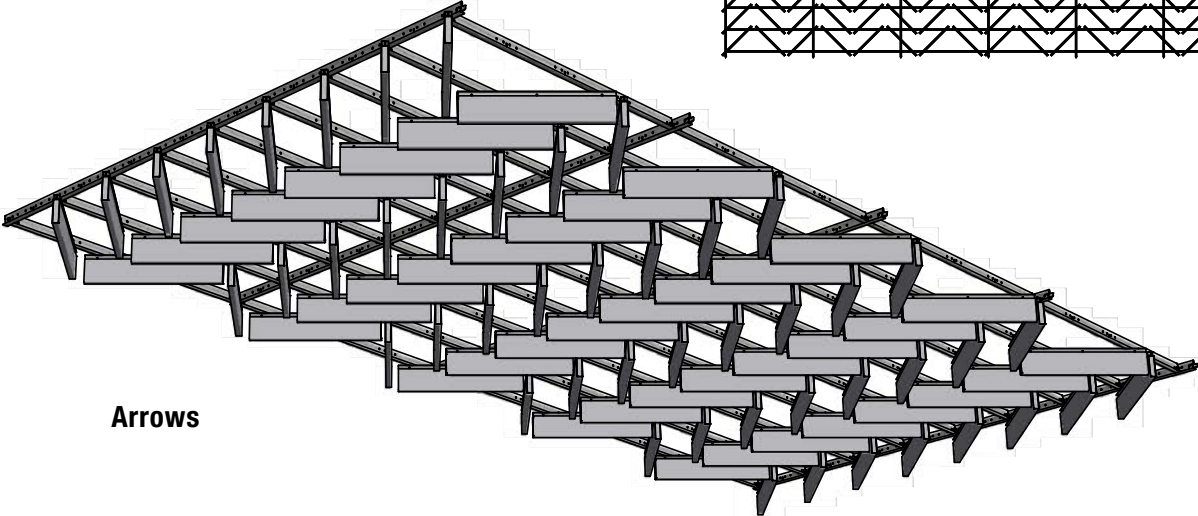
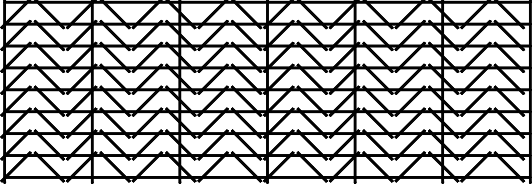

**Arrows**

# METALWORKS™ Blades – Classics™

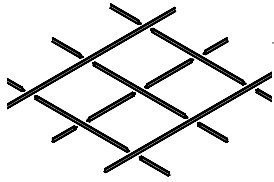

2 x 2 Layouts

---

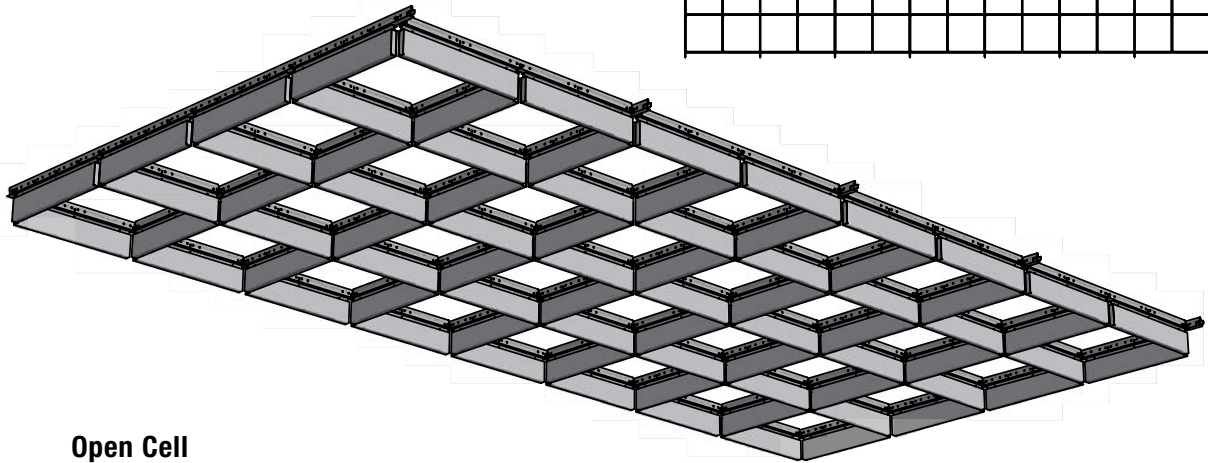

**Open Cell**

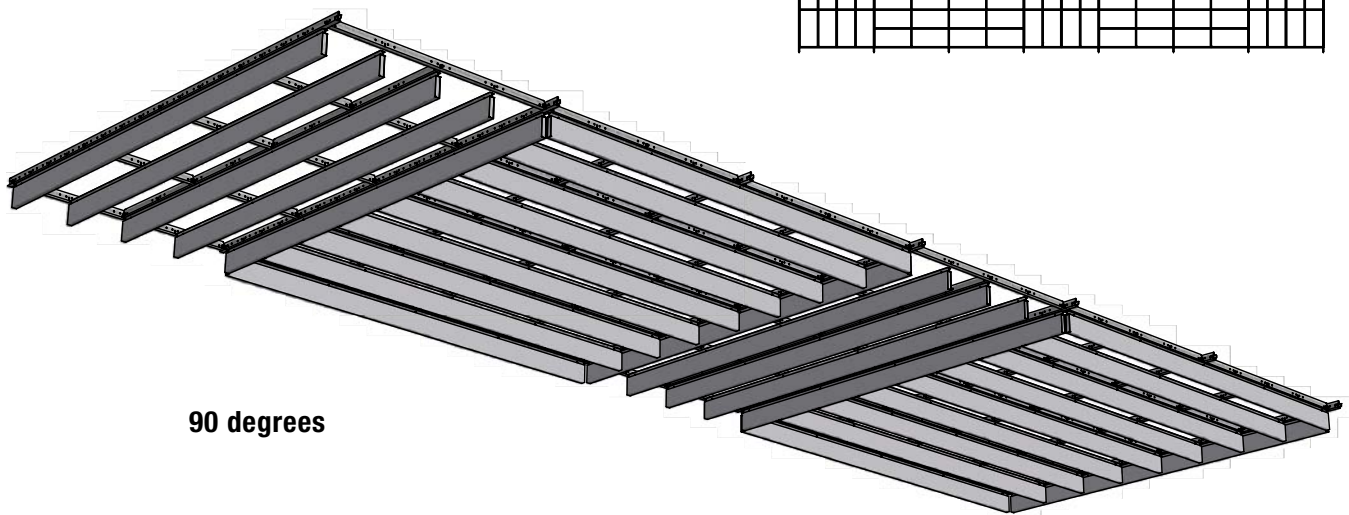
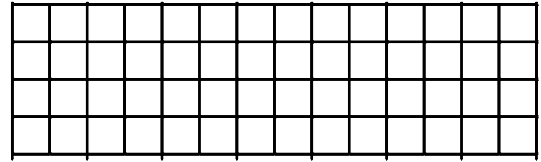

**90 degrees**

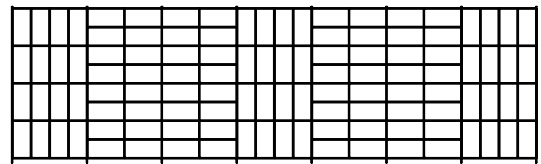



# METALWORKS™ Blades – Classics™

## 2 x 4 Layouts

---

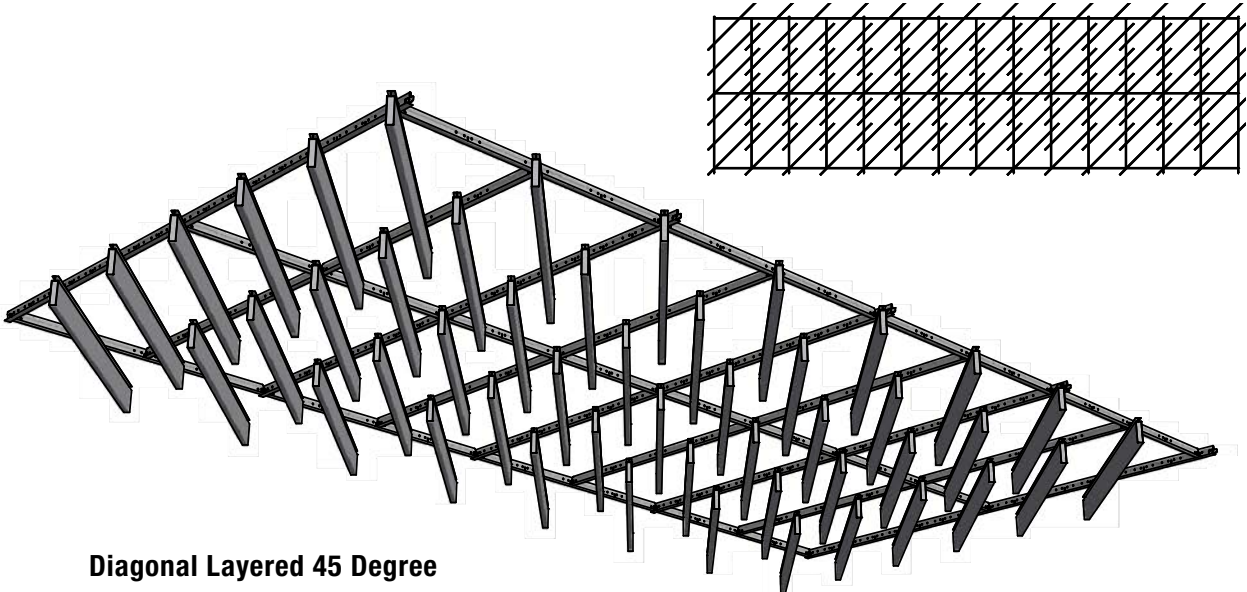
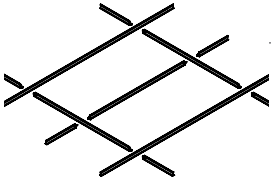

**Diagonal Layered 45 Degree**

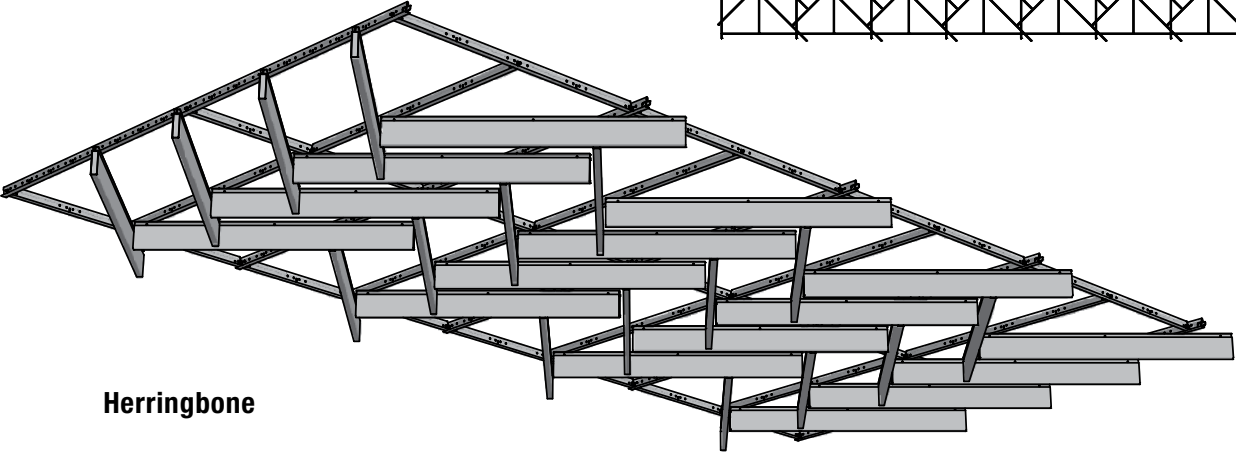
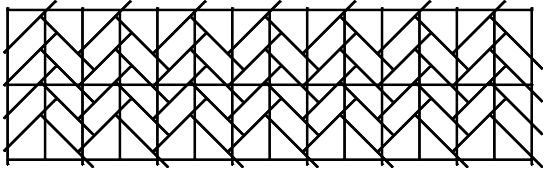

**Herringbone**

# METALWORKS™ Blades – Classics™

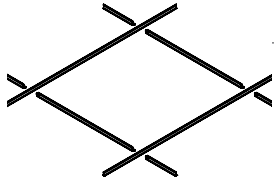

4 x 4 Layouts

---

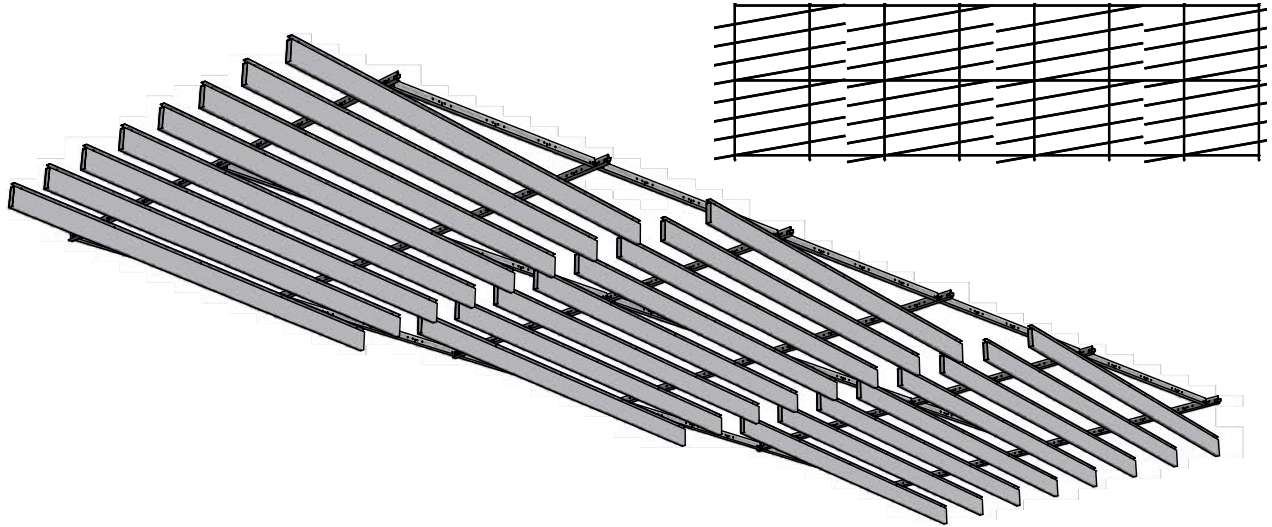

**8 Ft Diagonal 10 Degree**

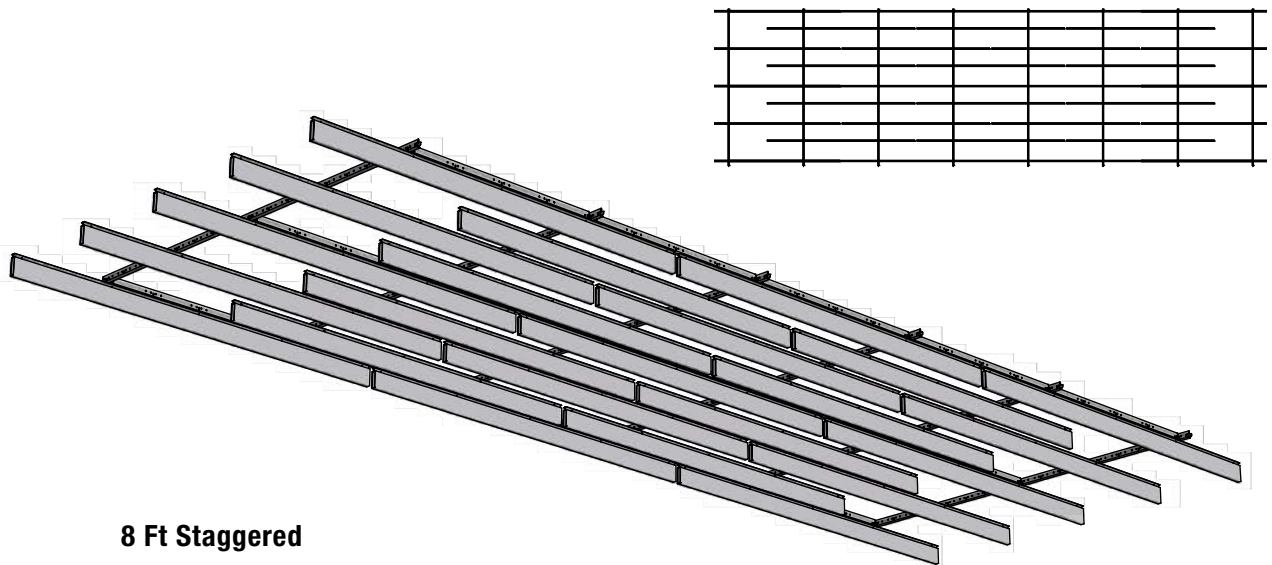

**8 Ft Staggered**

# METALWORKS™ Blades – Classics™

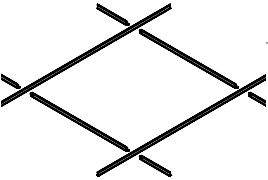

## 4 x 4 Layouts

---

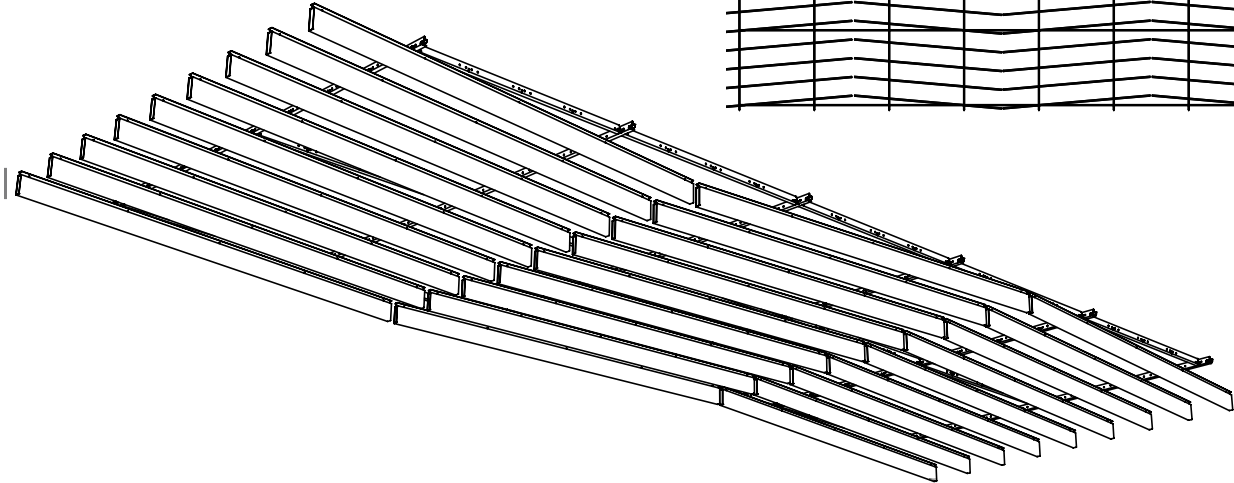

**8 Ft Wave 5 Degree**

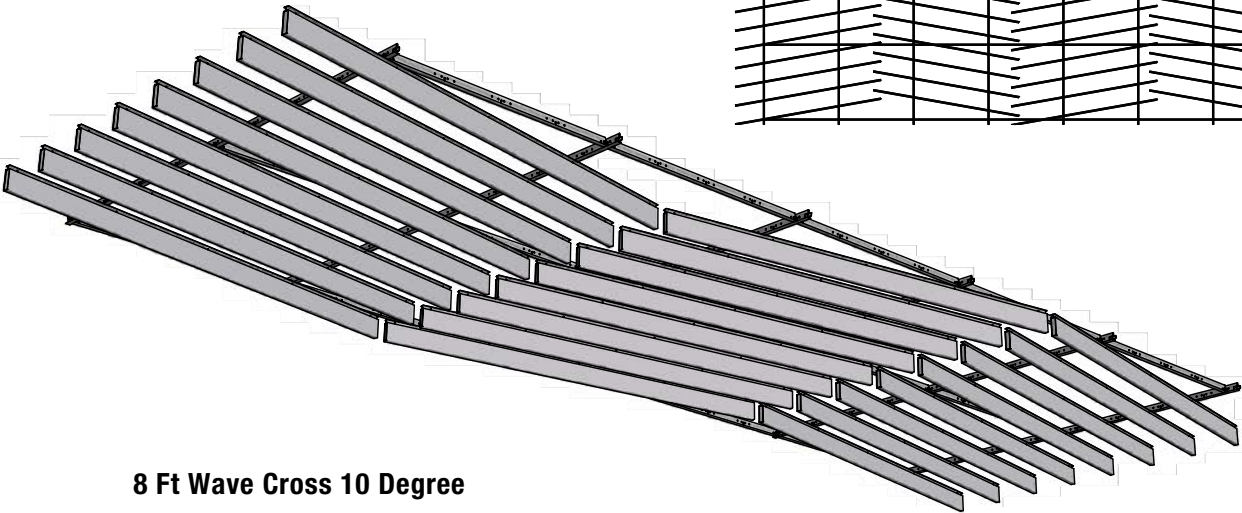

**8 Ft Wave Cross 10 Degree**

# METALWORKS™ Blades – Classics™

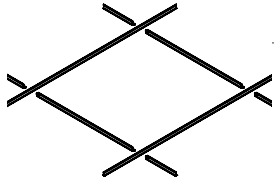

4 x 4 Layouts

---

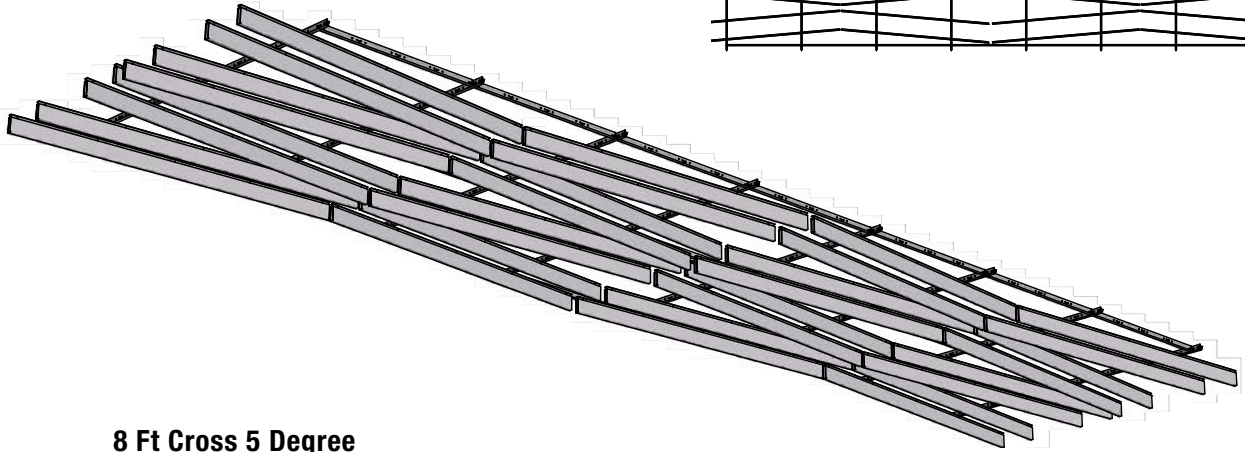
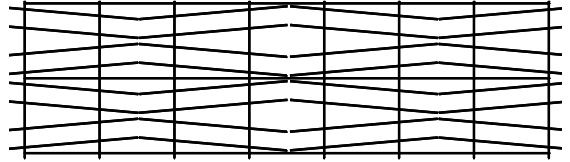

**8 Ft Cross 5 Degree**

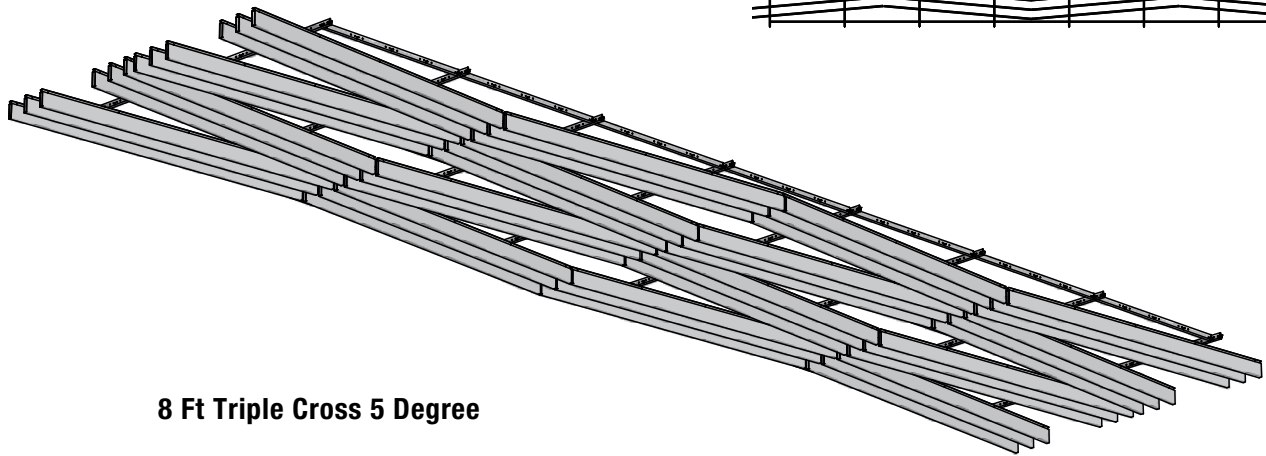
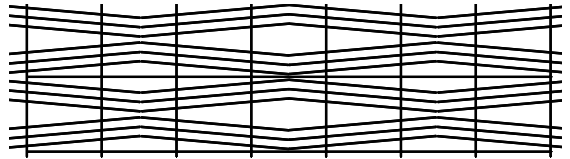

**8 Ft Triple Cross 5 Degree**

# METALWORKS™ Blades – Classics™

Variable Module: Grid Layout Based on Your Personal Design

---

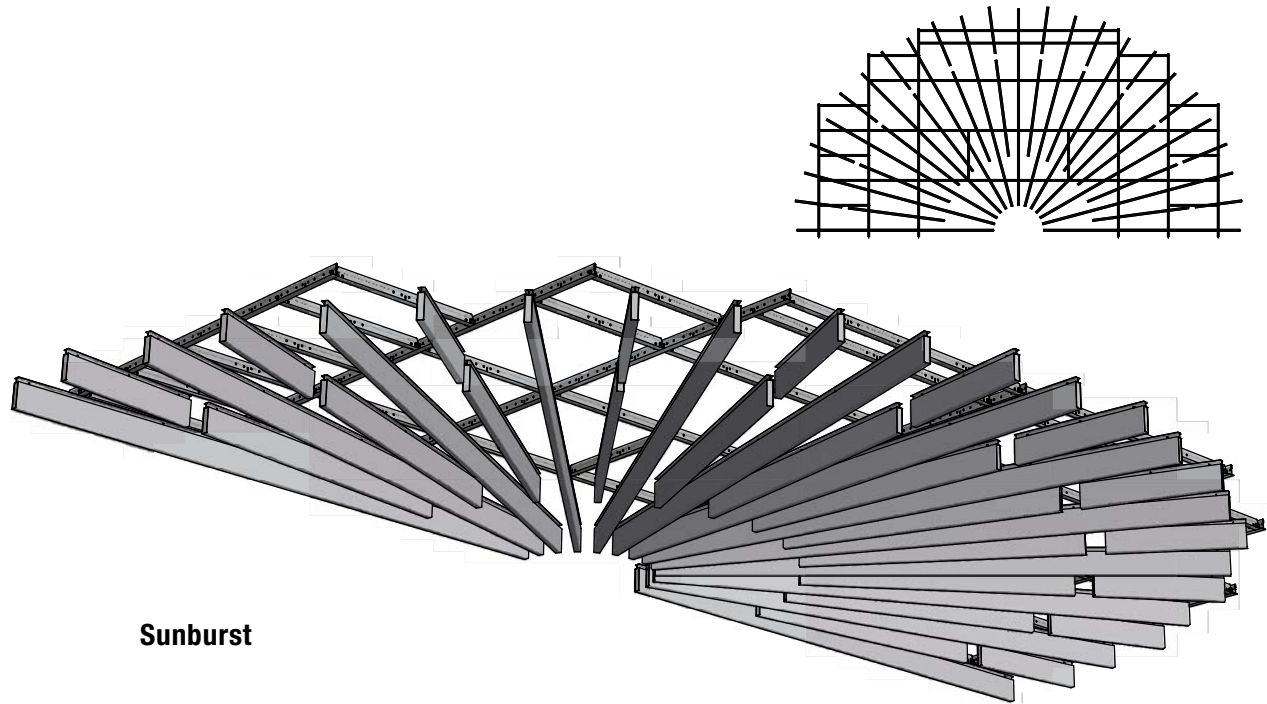

**Sunburst**



## **Design Considerations:**

All designs shown require only two clips per panel positioned at least 4" from the end of each linear panel.  
All designs shown are possible using intermediate duty suspension system.

# METALWORKS™ Blades – Classics™

Linear Panels with Acoustical Options  
smooth texture

CAD/Revit® drawings at:  
[armstrongceilings.com](http://armstrongceilings.com)

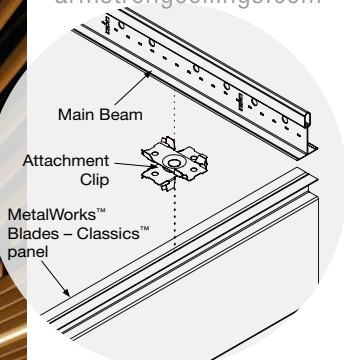
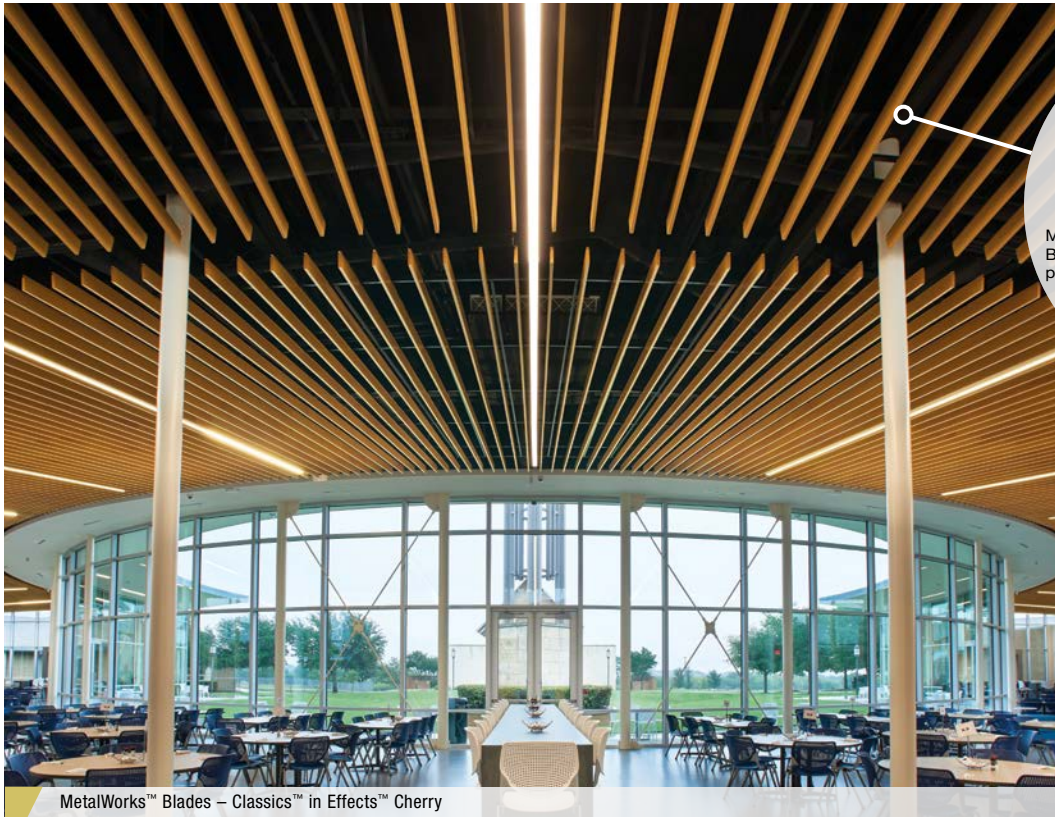

plus capabilities  
to do more

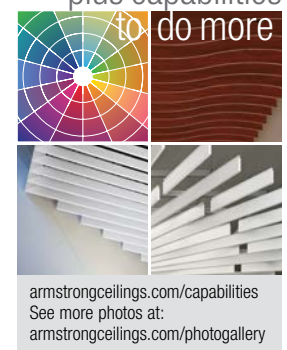

[armstrongceilings.com/capabilities](http://armstrongceilings.com/capabilities)  
See more photos at:  
[armstrongceilings.com/photogallery](http://armstrongceilings.com/photogallery)

MetalWorks™ Blades – Classics™ in Effects™ Cherry

Durable metal vertical panels in upscale linear designs are available in acoustical or non-acoustical options.

## KEY SELECTION ATTRIBUTES

- Now available in 23" and 47" lengths for creative design layouts
- Blades™ panels come with two factory-installed end caps, one end cap, or no end caps
  - Join several Blades™ panels together to create a longer run
  - Use double end capped panel for access areas
- Introducing the Field Cut End Cap for maximum jobsite flexibility (sold separately)
- Six Wood Looks Effects™ finishes
- Create acoustical or non-acoustical upscale linear designs
- Blades panel spacing is variable to accommodate a variety of design and acoustical needs
- MetalWorks™ Blades – Classics™ panels are part of the Sustain™ portfolio and meets the most stringent sustainability compliance standards today
- Fast, easy installation with standard Prelude® XL® 15/16" or 360° painted suspension systems



Field Cut End Cap shown inserted and uninstalled.

## COLORS

Due to printing limitations, shade may vary from actual product.

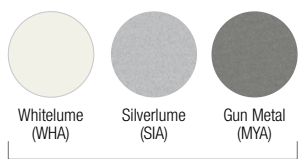

Part of the Sustain® portfolio, meeting sustainability compliance standards



## PERFORATION OPTIONS

(1:2 scale shown)

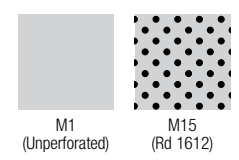

Additional sizes and colors may be available. For more information, visit our web site at [armstrongceilings.com/metalworks](http://armstrongceilings.com/metalworks) or contact Architectural Specialties TechLine at 1 877 276-7876 for custom panel lengths.

# METALWORKS™ Blades – Classics™

## Linear Panels with Acoustical Options

smooth texture

**Declare™**  
Living Building  
Challenge Compliant

**SUSTAIN™**  
High Performance  
Sustainable  
Ceiling Systems  
Unperforated (M1)

UP TO **80%** RECYCLED CONTENT

**LEED®**

- energy management
- construction waste mgmt
- regional materials
- design for flexibility
- EPD
- recyclable/extended producer resp.
- biobased materials
- recycled content
- sourcing of raw materials
- material ingredient reporting
- low emitting materials
- lighting quality
- acoustics

For LEED contribution contact TechLine

### VISUAL SELECTION

Edge Profile	Item No. ♦	Description/Dimensions L x W x D (Inches) Custom Sizes Available	
<b>METALWORKS™ Blades – Classics™</b>			
	<b>8157</b> ♦	Vertical panel with caps on both ends 94-1/2 x 4 x 1"	
	<b>8156</b> ♦	Vertical panel with caps on both ends 46-1/2 x 4 x 1"	
	<b>8155</b> ♦	Vertical panel with caps on both ends 22-1/2 x 4 x 1"	
	<b>7202</b>	Vertical panel with cap on one end 96 x 4 x 1"	
	<b>7203</b>	Vertical panel with no end caps 96 x 4 x 1"	

♦ When specifying or ordering, include the appropriate perforation and color suffix with the item number (e.g., 7201 **M 1 5 E X M P**).

† With M15 perforation

NOTE: 6" panel depth option available as a custom product.

Additional custom options include 12" x 72" and 24" x 72" panels in lengths up to 144".

### PERFORMANCE

LOCATION DEPENDENT

Dots represent high level of performance.

WITH INFILL PANEL

Sabins/Panel†	Wash	Scrub	Soil
2.5	•	•	•
1.2	•	•	•
0.6	•	•	•
2.5	•	•	•
2.5	•	•	•

Durability

### ACCESSORIES

Item Number	Description	Pieces/Carton
<b>7204</b> ♦♦	MetalWorks™ Blades – Classics™ Attachment Clip (SS – Stainless Steel and KO – Black Oxide)	100
<b>7205</b>	MetalWorks™ Blades – Classics™ Alignment Device	24
<b>8158</b> ♦	MetalWorks™ Blades – Classics™ 1' x 4" Field Cut End Cap	10

♦ When specifying or ordering, include the color suffix with the item number (e.g., 7201 **M 1 5 E X M P**).

♦♦ When specifying or ordering, include the appropriate 2-letter color suffix, SS – Stainless Steel or KO – Black Oxide, (e.g., 7204 **S S**).

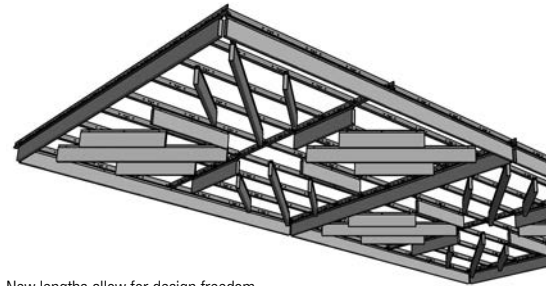

New lengths allow for design freedom. See other possible design layouts in our MetalWorks™ Blades technical guide.

### SUSPENSION SYSTEMS

15/16"

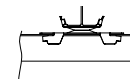

Prelude® XL® suspension system (Pgs. 458-459)  
(Black) or 360° Painted Grid (Pg. 450)

### PHYSICAL DATA

**Material**  
Aluminum – thickness 0.032"

**Surface Finish**  
Factory-applied polyester paint. Available in White, Silver Grey, Gun Metal Grey, and Effects™ Wood Looks powder-coated, post-production finishes. Custom colors also available. Contact TechLine for custom color matching requests at 1 877 276-7876.

**Fire Performance**  
Tested per ASTM E84. Flame Spread Index 25 or less. Smoke Developed Index 50 or less.

CAN/ULC S102 surface burning characteristics. Flame Spread Rating 25 or less. Smoke Developed Classification 50 or less.

### Acoustical Options

Perforated panels are supplied with a black fiberglass fleece acoustic infill bag to absorb sound (varies by Blades™ panel length).

**Design Support**  
Project management assistance is available by calling TechLine customer support at 1 877 276-7876.

**Design Considerations**  
When installed, panels hang 4-7/8" below grid face. Panels can be supported by intermediate duty main beams or cross tees, with 2 attachment clips per panel. See MetalWorks™ Blades – Classics™ brochure online for additional design lay-outs.

MetalWorks Blades – Classics can be cut in the field only when using the Field Cut End Cap. See installation instructions for details.

### Seismic Restraint

MetalWorks™ Blades – Classics™ are approved for application in all seismic areas when installed per the seismic guidelines in the Armstrong Ceilings installation instructions.

**Warranty**  
Details at armstrongceilings.com

**Weight; Square Feet/Carton**  
1.43 lbs/LF

# TAKE THE NEXT STEP

## 1 877 276 7876

Customer Service Representatives  
7:45 a.m. to 5:00 p.m. EST  
Monday through Friday

**TechLine** – Technical information, detail drawings,  
CAD design assistance, installation information,  
other technical services – 8:00 a.m. to 5:30 p.m. EST,  
Monday through Friday. FAX 1 800 572 8324  
or email: [techline@armstrongceilings.com](mailto:techline@armstrongceilings.com)

## [armstrongceilings.com/commercial](http://armstrongceilings.com/commercial)

Latest product news  
Standard and custom product information  
Online catalog  
CAD, Revit®, SketchUp® files  
A Ceiling for Every Space® Visual Selection Tool  
Product literature and samples – express service  
or regular delivery  
Contacts – reps, where to buy, who will install

## YOU INSPIRE™ SOLUTIONS CENTER

1 800 988 2585  
email: [solutionscenter@armstrongceilings.com](mailto:solutionscenter@armstrongceilings.com)  
[armstrongceilings.com/youinspire](http://armstrongceilings.com/youinspire)

### Design Assistance

Collaborative design  
Detail drawings  
Specifications  
Planning and budgeting

### Pre-construction Assistance

Layout drawings for standard  
and premium products  
Project installation recommendations  
Contractor installation assistance

**you inspire™**  
solutions center

helping to bring your one-of-a-kind ideas to life

Revit® is a registered trademark of Autodesk, Inc.; SketchUp® is a registered trademark of Trimble Inc.;  
RAL® is a registered trademark of RAL gGmbH; Declare™ is a service mark of International Living Future Institute;  
LEED® is a registered trademark of the U.S. Green Building Council;  
Inspiring Great Spaces® is a registered trademark of AFI Licensing LLC  
All other trademarks used herein are the property of AWI Licensing LLC and/or its affiliates  
© 2019 AWI Licensing LLC Printed in the United States of America

[armstrongceilings.com/blades](http://armstrongceilings.com/blades)

Inspiring Great Spaces®

**Armstrong®**  
CEILING SOLUTIONS