

METALWORKS™ Blades™ Concepts™

Assembly and Installation Instructions

1. GENERAL

1.1 Product Description

MetalWorks Blades Concepts are vertical profile aluminum composite panels designed to be suspended from the MetalWorks Blades Concepts suspension bar. MetalWorks Blades Concepts are available in three lengths.

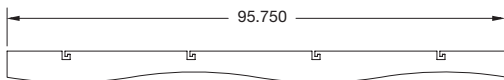
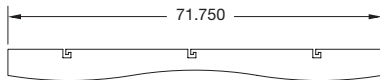
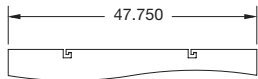

1.2 Storage and Handling

MetalWorks Blades Concepts should be stored in a dry interior location and shall remain in the original cartons prior to installation to avoid damage. The cartons should be stored in a flat, horizontal position. Proper care should be taken when handling the blades to avoid damage and soiling.

1.3 Site Conditions

Building areas to receive ceilings shall be free of construction dust and debris.

1.4 Precautionary Measures

Edges of metal panels can be extremely sharp! Handle metal carefully to avoid injury. Always wear safety glasses and gloves when working with metal.

1.5 Fire Performance

MetalWorks Blades Concepts may obstruct or skew the existing or planned fire sprinkler water distribution pattern, or possibly delay the activation of the fire sprinkler or fire detection system. Designers and installers are advised to consult a fire protection engineer, NFPA 13, and their local codes for guidance on the proper installation techniques where fire detection or suppression systems are present.

1.6 HVAC Design & Operation

Proper design for both supply air and return air, maintenance of the HVAC filters and building interior space are essential to minimize soiling. Before starting the HVAC system, make sure supply air is properly filtered and the building interior is free of construction dust.

1.7 Plenum

Since panels are installed from below, MetalWorks Blades Concepts require minimal clearance above the suspension system. Panels never need to travel into the plenum space during installation or removal.

2. INSTALLATION

2.1 Suspension System

MetalWorks Blades Concepts are not designed for sloped installations.

MetalWorks Blades Concepts install on aluminum suspension bars, which are hung with the Blades Hanging Kit suspension assemblies. Each suspension bar requires one hanging kit which includes four hanging assemblies.

1. Determine the direction of the blades, per the RCP; suspension bars will be installed perpendicular to the length of the blades. The suspension bars should be installed 11-7/8" OC from the desired starting location of the blade end and continuing 24" O.C. across the field of the installation, making the last row end 11-7/8" from the end of the run of blades. (Refer to detail below).

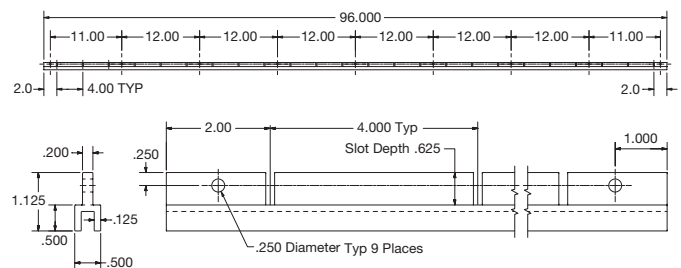

2. Determine the location to hang the first suspension bar.

Blades Hanging Kit – Item #6655 (one kit contains four assemblies; each suspension bar uses one kit with the assemblies located 12" from the end and then at 2' OC across the length of the bar in pre-drilled holes).

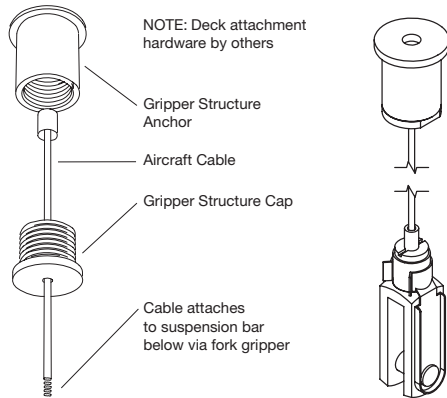

NOTE: In cases where attachment to structure is not possible at 24" centers, hanging kit assemblies can be spaced at a maximum of 36" O.C. along the length of the bar and within 12" of each end of the bar. (holes for the Attachment Pin will have to be drilled in the field).

3. Fasten the gripper structure anchor to the structure. Use fasteners (by others) that are compatible with the structure.
4. Thread the aircraft cable through the hole on the gripper anchor cap.
5. Thread the gripper anchor cap onto the gripper structure anchor.
6. Attach the fork gripper to the suspension bar by removing the attachment pin from the fork. Install the fork over the vertical fin of the suspension bar to align with the through holes.

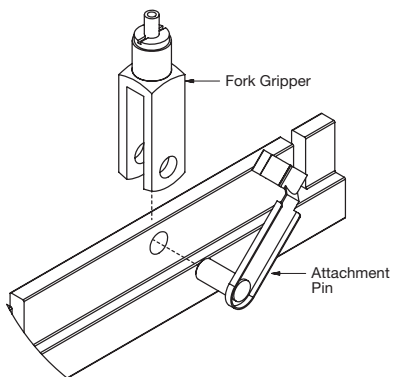

7. Slip the attachment pin through the fork and hole in the suspension system and secure attachment pin to the top of the fork gripper.

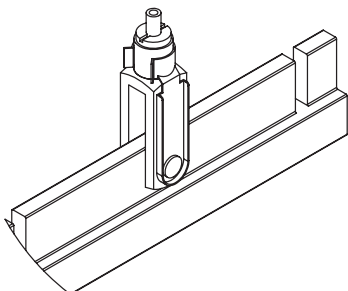

8. Runs of suspension bars can be achieved using the end-to-end connector (item 6651AB).

Slip the connector over the vertical fin of two adjacent suspension bars, and align the holes in the connector with the holes in the suspension bar. Attach them together using the provided fasteners. This can be done on both ends of the 96" suspension bar.

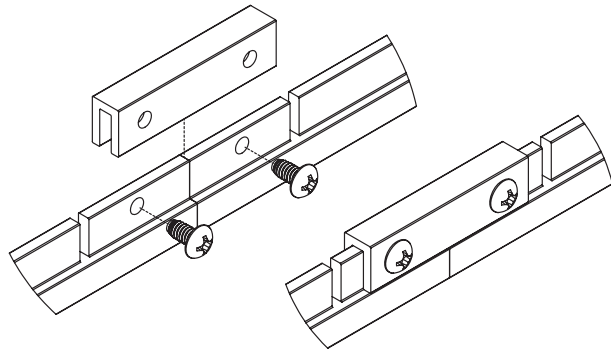

It may be necessary to cut a suspension bar to fit the dimensions of the space. See MetalWorks™ Cutting Instructions LA-295518 for detailed information about cutting Armstrong metal ceilings. This document discusses the advantages and disadvantages of several types of equipment and how they are used when cutting Armstrong products.

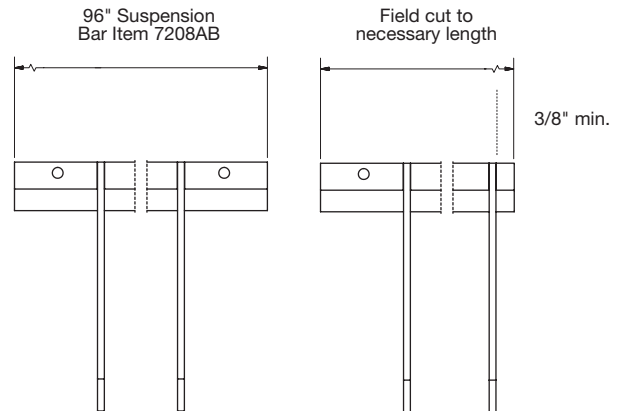

To touch up cut ends of the suspension bar, use a commercially available matte black paint.

9. At the perimeters of the installation the suspension bars can be cut to length (see below). The suspension bars are extruded aluminum and it is recommended that they are cut with a metal cutting chop saw or battery powered circular saw. When cutting to length, be sure to leave at least 3/8" of material from the last notch to the end of the suspension bar.

2.2 Suspension Layout

Refer to the procedures in section 2.1 to determine suspension bar hanging locations. These will be installed 11-7/8" O.C. from the desired starting location of the blade end and continue 24" O.C. across the field of the installation (see below).

NOTE: The first row of suspension bars must be installed at least 13-7/8" O.C. from the wall to ensure a minimum of 2" clearance necessary for proper blade installation. Notches to receive the blades are spaced at 4" O.C. along the length of the suspension bars. See typical RCP view below.

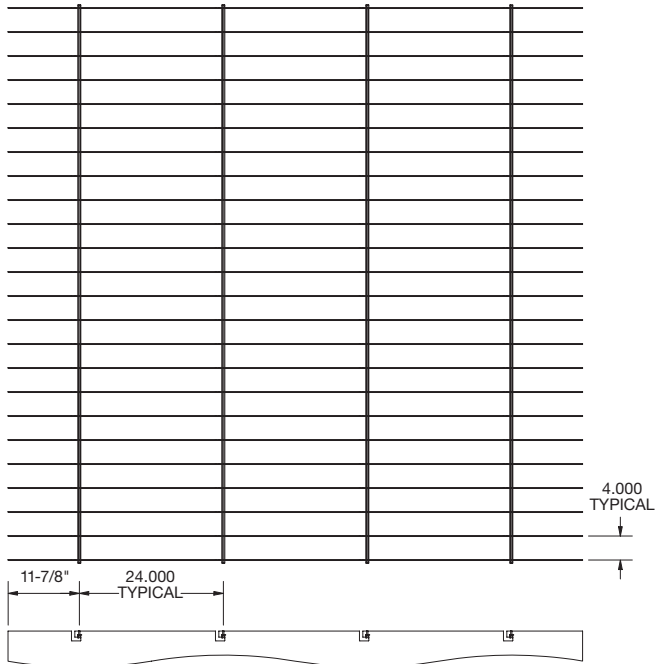

Layouts of suspension bar longer than 8' will require multiple suspension bars to be spliced together. End-to-end connectors (item 6651AB) are required to splice the suspension bars together and maintain proper spacing and alignment.

3. BLADE INSTALLATION

MetalWorks™ Blades™ Concepts™ require two people to align and install each 8' blade safely. Blades cannot be used to support any other material. Blades can be rotated 180 degrees.

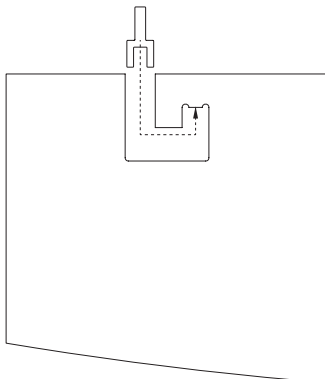

Each blade is attached to the suspension system by means of hanging the factory hook cut out in the blade over the vertical flange of the suspension bar.

The suspension bar allows for rows of blades every 4". Joints between panels should be staggered between blade runs as shown below.

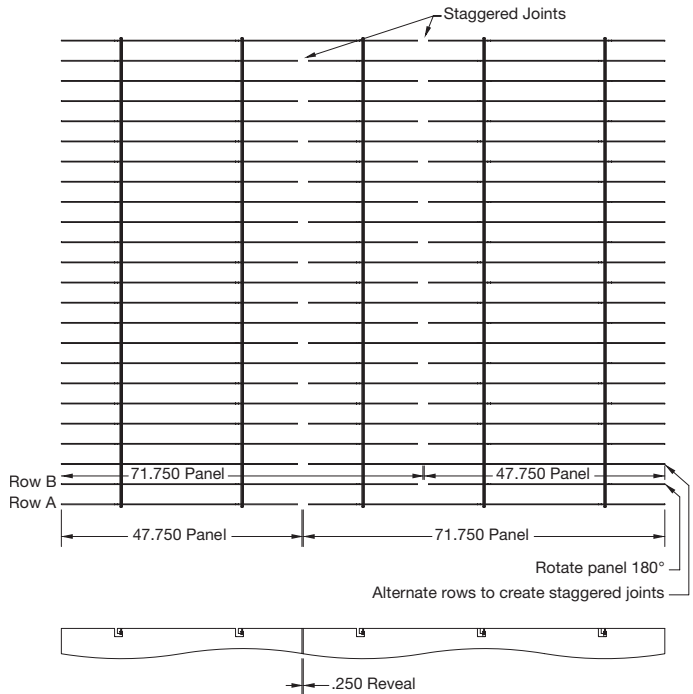

The MetalWorks Blades Concepts wave design is a 4' pattern. 6' blades should only be installed end-to-end with 4' or 8' blades in order to keep the wave design pattern. (Refer to section 1.1 for blade profiles at 4', 6', and 8' lengths).

4' and 8' Blades can be installed in the same direction or in alternating directions as shown below.

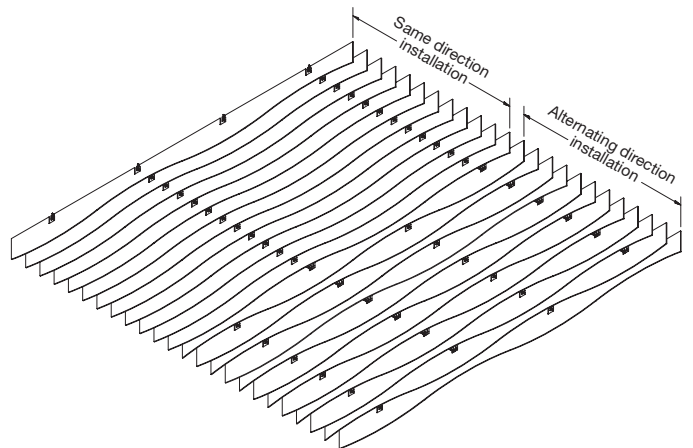

Product classified as an "architectural element" (no bracing is needed)

- must be able to swing 360 degrees
- must not be allowed to contact essential components in the ceiling
- since aircraft cables are used the maximum swing that can be expected is 18"

4. SEISMIC

This system has been tested and approved for installation in all IBC Seismic Design Categories. ASCE 7 provides an exception to the restraint requirement for architectural components stated in section 13.5.1, provided that:

- The connection to the structure shall allow a 360° range of motion in the horizontal plane
- The component may not cause damage to an essential building element

(refer to p.17 in the Armstrong “What You Need to Know” document regarding seismic installations).

The International Building Code allows architectural components to swing freely as long as they will not be damaged or cause damage. Cable lengths less than 20" will generate the greatest amount of pendulum reaction during a seismic event and should, therefore, be avoided.

When it is not practical to use cables greater than 20" long, allow lateral clearance around the architectural component equal to, or greater than, the length of the cable.

Architectural components suspended from cables greater than 20" long will swing no more than 8". Restraint of canopies has proven to be ineffective and is not recommended.

OSHPD/DSA installations may require additional attachment from blade to suspension bar. Standard blades do not come with pilot holes pre-drilled, however, blades can be ordered with pre-drilled pilot holes adjacent to the hook details (as shown in detail below) by contacting TechLine at 1 877 276 7876. 18 gauge hanger wire should be inserted to bridge over the suspension bar and the ends twisted together with four turns.

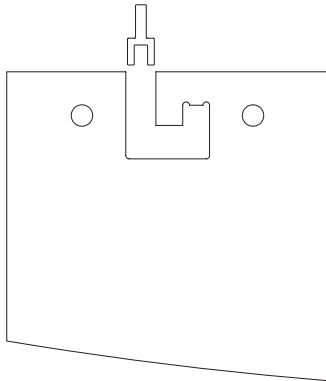

5. CLEANING

An abrasive or strong chemical detergent should not be used. A mild detergent diluted in warm water, applied with a soft cloth, rinsed, and wiped off with a chamois will maintain the blades in good condition.

MORE INFORMATION

For more information, or for an Armstrong representative, call 1 877 276 7876.

For complete technical information, detail drawings, CAD design assistance, installation information, and many other technical services, call TechLine services at 1 877 276 7876 or FAX 1 800 572 TECH.

For the latest product selection and specification data, visit armstrongceilings.com/metalworks

All trademarks used herein are the property of AWI Licensing Company and/or its affiliates
© 2018 AWI Licensing Company • Printed in the United States of America

BPLA-297931-218

Armstrong[®]
CEILING SOLUTIONS