

OPTIMA® PB and LYRA® PB CAPZ™

Installation Instructions

For best installation results:

Optima® PB and Lyra® PB panels are installation directional (refer to arrow on the back of panel). Arrows and text are larger than they appear on panels.

1. GENERAL

1.1 Product Description

Optima PB and Lyra PB Capz products are made from fiberglass. Panels are demountable, or 100% downward accessible. Panels are designed to be attached to a conventional 15/16" wide T-bar suspension system. All panels can be removed and re-installed without tools or special equipment for access to the plenum. (Fig 1)

Panels are available in seven standard sizes:

24" x 48", 24" x 60", 24" x 72", 24" x 96", 36" x 36", 48" x 48", and 48" x 96".

For seismic installations refer to Section 9.

Optima PB and Lyra PB Capz panels have reverse tegular edges. Panels are pre-drilled to accept hardware caps. Hardware caps attach to threaded studs which clip onto the suspension system. Unlike many conventional lay-in ceiling products, the Capz edge detail does not lay into the suspension system.

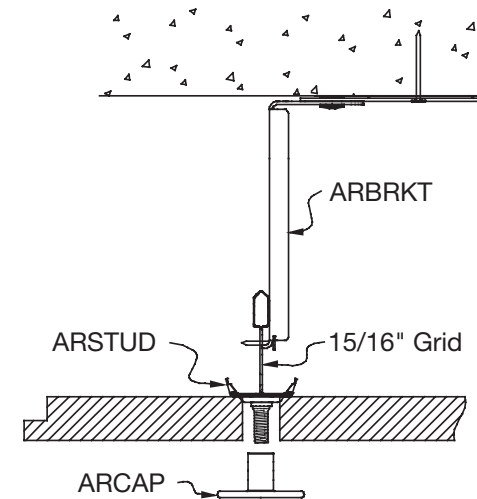

(Fig 1)

1.2 Surface Finish

Optima® PB and Lyra® PB Capz™ panels feature the Armstrong® DuraBrite® finish. The surface of these panels is scratch- and soil-resistant, have high light reflectance, and is washable. The panel edges are finished with a factory-applied paint finish.

For minor surface or edge scratches on Optima PB and Lyra PB Capz, use Armstrong SuperCoat™ Touch-up Paint Item #5761. Touch-up recommendations are provided later in this document (Section 6.7).

Black Lyra PB Capz panels feature an acoustically transparent scrim. The panel surface and edges are finished with a factory applied paint.

1.3 Storage and Handling

The ceiling panels must be stored in a dry interior location and remain in cartons prior to installation to avoid damage. The cartons must be stored in a flat position. Proper care should be taken when handling to avoid damage or soiling.

NOTE: Panels feature exposed edges. Exercise appropriate care to avoid unnecessary contact or damage to the panel edges. Remember that the grid flanges will not conceal panel edge damage. Black paint on Lyra PB Capz can scuff or mar when handled. Please use caution when handling and installing Lyra PB Capz.

1.3.1 Working With Fiberglass Products

FIBERGLASS CEILINGS

MAN-MADE VITREOUS FIBER CEILING PANELS

▲ WARNING THIS PRODUCT CONTAINS MAN-MADE VITREOUS FIBERS AND CRYSTALLINE SILICA, A POSSIBLE CANCER AND RESPIRATORY TRACT HAZARD. CAN CAUSE TEMPORARY RESPIRATORY, SKIN, AND EYE IRRITATION.

1.3.2 Precautionary Measures – During the installation, make certain that the work site is well ventilated and avoid breathing dust. If high dust levels are anticipated during installation such as with the use of power tools, use appropriate NIOSH designated dust respirator. All power cutting tools must be equipped with dust collectors. Avoid contact with skin or eyes. Wear long-sleeved, loose-fitting clothes, gloves, and eye protection.

1.3.3 First Aid Measures – If contact occurs, flush eyes and skin irritation with plenty of water for at least 15 minutes and remove contaminated clothing. After installing material, wash with warm water and mild soap. Wash work clothes separately from other clothing. Rinse washer thoroughly. Refer to Armstrong Ceilings MSDS (which includes information on established occupational exposure limits) which are available from Armstrong Ceilings or your employer.

1.4 Site Conditions

Building areas to receive ceilings must be free of construction dust and debris. These products are not recommended for exterior applications or where standing water is present or where moisture will come in direct contact with the ceiling.

1.5 Plenum

Installation of the system is within 6" of the structure. Design limitations require a clear plenum and are not suitable for plenum spaces crowded with services or obstructions.

1.6 Fire Sprinklers

Capz panels, as with other architectural features located at the ceiling, may obstruct or skew the planned fire sprinkler water distribution pattern, or possibly delay or accelerate the activation of the sprinkler or fire detection systems by channeling heat from a fire either toward or away from the device. Please consult a fire protection engineer, NFPA 13, and the local codes for guidance where automatic fire detection and suppression systems are present.

2. COMPONENTS

2.1 Grid

Installations use standard Prelude® 15/16" T-bar grid. Grid can be attached directly to the structure with rigid connectors or suspended with 12 ga. hanger wire.

2.2 Capz™ System Connectors

2.2.1 QSUTC – is a rigid attachment clip to fasten the grid to structure.

2.2.2 ARBRKT – is an adjustable hanger bracket to fasten the grid to structure.

2.2.3 ARSTUD – is an adjustable hanger bracket to fasten the grid to structure.

2.2.4 ARCAP – screws through the panel onto the ARSTUD to align and support the panel. Caps are available in white and black. Caps fit onto a 1/4-20 stud and have a 1-1/4" diameter face to support the panel.

2.2.5 ARPLUG – locks the cross tee tabs into the slot along the outside row of main beams of Capz™ installations.
NOTE: ARPLUGs only work with Armstrong® XL® cross tee end details.

2.2.6 Panels – Panels are available in standard nominal sizes including: 2' x 4', 2' x 5', 2' x 6', 2' x 8', 3' x 3', 4' x 4', and 4' x 8'. Panels are pre-drilled with a 1/2" hole that easily fits over the ARSTUD.

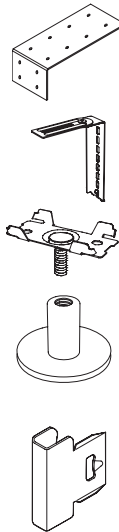

3. REFLECTED CEILING PLAN

Refer to the reflected ceiling plan to determine the proper grid layout. Panels require grid above all pre-drilled holes in the panels.

3.1 Grid Layout

Grid layout uses standard main beams and cross tees. Main beams usually run the long direction of the installation. On-center spacing will be determined by the panel configuration. Cross tee length and spacing is also determined by the panel configuration. See grid layout example on pages 8 and 9.

4. CAPZ™ GRID INSTALLATION

Suspension grid is attached directly to the structure with rigid brackets.

4.1 Grid Layout

Grid layout is very important for ease of panel fit, alignment, and best visual. Refer to the reflected ceiling plan to determine the correct grid components and on-center spacing.

4.2 Grid Layout

Brackets are used to attach the main beam to structure. Brackets are recommended within 12" of the ends and not more than 48" on center along the run of main beams. Brackets allow grid elevation adjustment from 1-3/4" to 5-1/2". Use heavy snips or a hacksaw to trim the bracket for different heights or as needed to level the grid. Avoid installing bracket on the main beam at the location of cross tees.

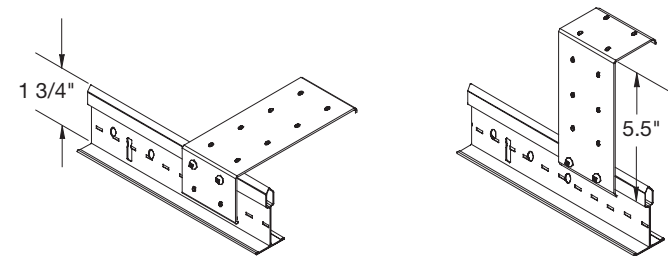

4.2.1 QSUTC – This clip must be accurately located before fastening to the structure for correct grid alignment and proper panel fit. Use a string line or laser to establish a straight row for bracket attachment. Use the appropriate fastener to anchor the clip to the structure.

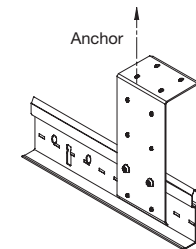

4.2.1 ARBRKT – This bracket is adjustable after fastening to the structure with a screw. This allows flexibility and minor variations for attachment to the structure. Use of a string line or laser is still recommended for this bracket. Grid can easily be aligned and squared for proper panel fit. Use the appropriate fastener to anchor the clip to the structure.

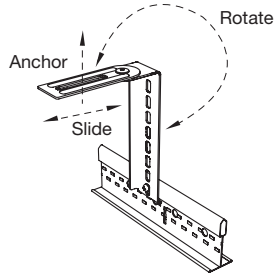

4.2.3 Hanger Wire – 12-gauge hanger wire can be used for Capz™ systems when the grid will be installed more than 5-1/2" below the structure. This suspended grid system must be installed to meet ASTM C636 standards and International Building Code seismic installations as required by local authority.

Using hanger wire to suspend the Capz system allows it to float. To keep this suspended grid system straight and square, you must add bracing. Because the panels mount from below, a solution is to add diagonal bracing across the corner of a main beam and cross tee, and fasten a piece of t-bar grid using pop rivets or sheet metal framing screws. Add diagonal bracing as needed to the Capz suspension grid to maintain the system straight and square for proper panel fit and alignment of panels.

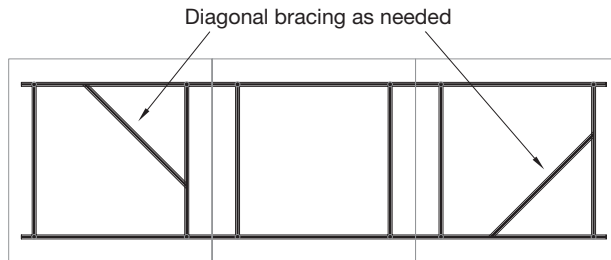

4.3 Install Grid

The grid must be installed straight, level, and square for best panel fit and alignment. Panels require grid above all the pre-drilled mounting holes. It's best to have two holes per panel at a main beam/cross tee intersection to keep the panel in place but not required. Some layout designs may have only every other panel with holes at a main beam/cross tee intersection. Panels cover or conceal most of the grid. Hangers and grid may be in the line of sight when installed at lower elevations. Consider using Prelude® 15/16" T-bar grid in Tech Black with Lyra® PB Capz™. Components can be field painted to blend in with the plenum.

4.3.1 Main Beams – Mains must be attached to the bracket so that a cross tee slot is located at the hole locations of the panel per the reflected ceiling plan. Panels extend 6" past the mounting hole. Trim off the main beam end approximately 3" past the first and last cross tee location to keep the main beam concealed.

4.3.1.1 First Row of Main Beams – Use clamps or vise grips to temporarily secure the first main to the brackets. Adjust for proper location and elevation. Use two sheet metal screws (Type #8 x 1/2 sharp point screw) to fasten the bracket to the main beam. Use the typical method to join sections of main beams for long runs.

4.3.1.2 Additional Rows of Main Beams – Brackets should be installed accurately for the proper main beam spacing as per the reflected ceiling plan. Use clamps or vise grips to temporarily secure the second main to the brackets. Check for the correct on-center spacing for the cross tee; adjust if necessary. Install two cross tees at the proper location.

CHECK SYSTEM SQUARENESS – this is a critical stage of grid installation. System squareness must be within 1/16". The system must be square or will result in improper panel fit, poor alignment, and an unacceptable visual. Measure diagonals, use a carpenter's square, or the 3-4-5 method to square the system. Secure the second main beam to the brackets with sheet metal screws. Install additional main beams keeping the system straight and square.

4.3.2 Cross Tees – All the cross tees along the outside rows of main beams will have a single tab inserted into the cross tee slot. To secure and align this tab, insert the ARPLUG along the right side of the cross tee tab.

NOTE: ARPLUGs only work with Armstrong® XL® cross tee end details. See ARPLUG detail in drawing on page 10.

5. INSTALL ARSTUD

Refer to the reflected ceiling plan for panel hole or stud locations. Panels may have all studs at a main beam/cross tee intersection, a combination of studs at main beam/cross tee intersections, and studs along the grid flange or on the grid flange only. ARSTUDs easily snap onto the grid flange. Make sure all four corner tabs lock onto the grid.

5.1 Grid Flange

The ARSTUD fits anywhere along the grid flange as needed. Standard panel stud locations are on 12" increments. Snap the ARSTUD onto the grid and slide it directly under a cross tee slot at the required spacing.

6. PANEL INSTALLATION AND CAPS

6.1 Panel Orientation

Install all Optima® PB and Lyra® PB Capz™ panels with the directional arrow in the same direction (requires a minimum of 1/4" reveal in one direction between panels and a minimum of 6" reveal in the other direction between panel rows) to provide installation consistency, uniform visual, and proper panel alignment. See details on page 10.

6.2 Large Panels

The use of two installers is recommended for panels exceeding 72". Having two installers for all size panel installations will ease the installation, minimize exposed edge damage, and help maintain proper panel alignment.

6.3 Panel Installation

Handle with clean hands, and use care to avoid soiling or damage.

Step 1: Gently raise the panel up until the 1/2" diameter holes fit over the 1/4" ARSTUDs

Step 2: While holding the panel up against the grid, partially thread 2 or 3 caps onto the stud to support the panel

Step 3: Insert all caps completely onto the stud finger tight

Step 4: Install remaining panels

- Align panels for uniform reveal
- Adjust minor corner elevations with threaded cap

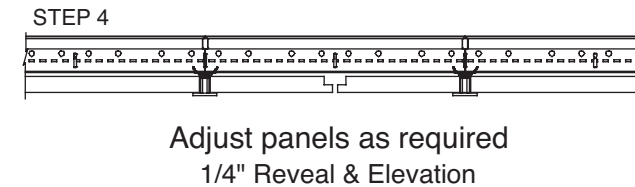
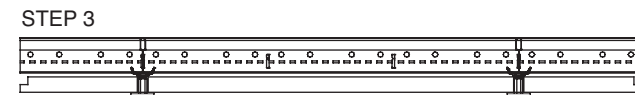
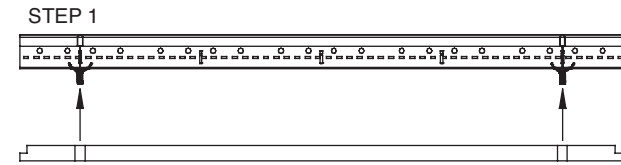

6.4 Panel Removal

Step 1: Loosen 2 or 3 caps that support the panel

Step 2: Remove the remaining cap

Step 3: While supporting the panel, remove all the caps

Step 4: Gently lower the panel down off the studs

6.5 Ceiling Penetrations

Capz™ panel installations will generally be full-size panels and will not usually cover the entire area wall to wall. Panels should not be installed in areas with major plenum services or obstructions that must pass through the panels. Some plenum penetrations may require not installing an Optima® PB or Lyra® PB Capz™ panel in the desired location, leaving that space open. However, the following guidelines will help when something must penetrate a panel.

6.5.1 Penetration Through the Panel – When the panel can be installed over the penetration – example: fire sprinkler, independent light cable, mounting bracket for AV equipment – cut a clearance hole in the panel at the correct location and install as usual.

The panel cannot support any type of mechanical device. It must be independently supported.

Hole edge treatment:

Cut the clearance hole 1" larger on all sides and field paint the cut edge

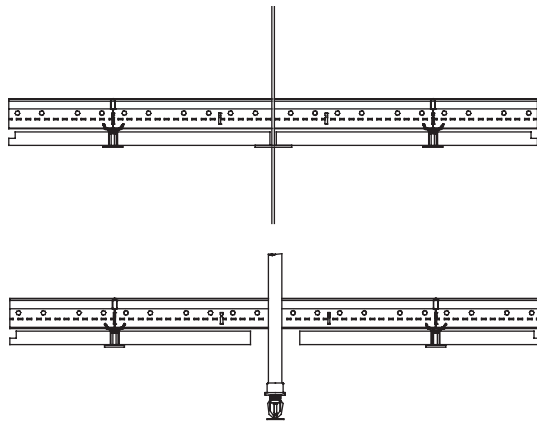

4.3.1.1 Notched Panel for Penetration – If the obstruction or penetration prevents the panel from fitting over it, you will need to notch the panel to fit around the penetration; e.g., structural brace, roof drain line, hangers for other services.

Step 1: Mark the penetration on the face of the panel

Step 2: Cut the notch or the corner off to provide 1" to 2" clearance around the penetration for ease of installation

Step 3: Provide additional panel support if you cut off a mounting hole. (See Section 6.6.1. for details)

Step 4: Field paint the exposed edges

Step 5: Install panel

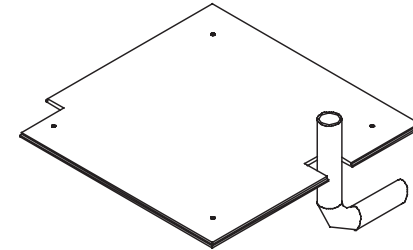

6.6 Field Cut Edges

Optima PB and Lyra PB Capz panel installation should be designed for full panels and no cut borders, however, you may need to field cut a panel in some installations.

6.6.1 Additional panel support is required whenever a panel mounting hole is trimmed off. This requires field drilling a new mounting hole and installing extra grid to relocate the ARSTUD.

Step 1: Field cut the panel as required to fit

Step 2: Relocate or install an extra cross tee within 6" of the trimmed edge or corner

Step 3: Install an ARSTUD on the grid to support the panel

Step 4: Measure the location of the new stud and transfer it to the trimmed panel. Drill a 1/2" hole at this location

Step 5: Field paint the cut edges and install the panel and caps as usual

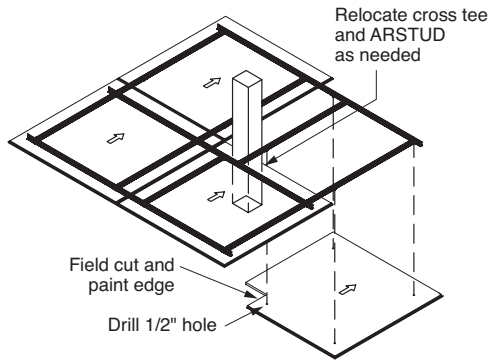

6.7 Touch-up Paint

For minor surface and edge scratches or to field paint a cut edge, use Armstrong® SuperCoat™ Touch-up Paint. This paint provides an excellent one coat edge treatment that will match the original panel. For minor surface and edge scuffing or scratches, or to field paint a cut edge for Lyra® PB Capz™ - Black, use a flat black or satin black general purpose spray paint.

6.7.1 Optima® PB and Lyra® PB Capz™ Surface Scratch or Edge Damage – Use a small brush to apply paint to the affected area. Only apply paint to the damaged area with a dabbing motion to prevent getting excess paint on the finished area. Blend or feather the paint edges to the existing panel surface.

6.7.2 Optima PB and Lyra PB Capz Field Cut Edges – Use a larger 1" wide brush to apply the touch-up paint to the cut edge. Apply a liberal amount of paint to the brush and coat several inches of the cut edge. For best results, use as few strokes as possible to cover the area. Avoid getting paint on the face of the panel and wipe off any excess as soon as possible. Paint will dry in approximately 30 minutes.

6.7.3 Lyra PB Capz - Black Surface Scratch, Edge Damage, or Field Cut Edges – Lightly spray flat or satin black paint onto affected area. Blend or feather spray to cover damage. May need to apply two coats to field cut edge. Black latex caulk can also be used to fix edge damage. For slight smudges or scuffing, wipe lightly with a damp cloth.

7. LIGHTS AND FIXTURES

Lights and fixtures that mount in panels may require additional suspension grid for support; e.g., speakers, can lights, life safety alarms, or sensors. Additional cross tees can be installed in the grid as necessary to mount and support other fixtures. Fixtures exceeding 20 pounds may require extra grid support.

8. SLOPED INSTALLATIONS (NON-SEISMIC ONLY)

Capz™ panels can be installed on a slope up to 20 degrees (and may require additional main runners for proper panel alignment and support) using the following guidelines:

- All main beams must be installed running up and down the slope
- If mains are suspended by hanger wire then the system must be braced as in section 4.2.3 and wires are required within 8" of the ends of all rows of mains
- All ARSTUDs must be screw attached to the grid with a low profile 1/2" sharp point framing screw (provided by contractor). One screw is required for each ARSTUD and can be located in either one of the factory pre-drilled holes
- All single cross tee insertions must use the STAC, or XTAC to lock the cross tee to the main beam
- All sloped installations must be approved by local authorities at plan review

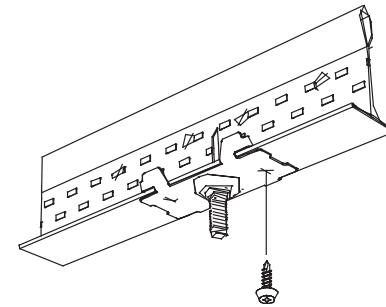

9. SEISMIC INSTALLATIONS

The following recommendations are for installations in areas of severe seismic activity and Seismic Design Category D, E, and F:

- All ARSTUDs must be screw attached to the grid with a low profile 1/2" sharp point framing screw (provided by contractor). One screw is required for each ARSTUD and can be located in either one of the factory pre-drilled holes
- Main beams must be rigidly attached to structure with the QSUTC or ARBRKT
- All single cross tee insertions must use the Single Tee Adapter Clip (STAC) to lock the cross tee to the main beam

Grid Layout Example

4' x 4' Panel Layout

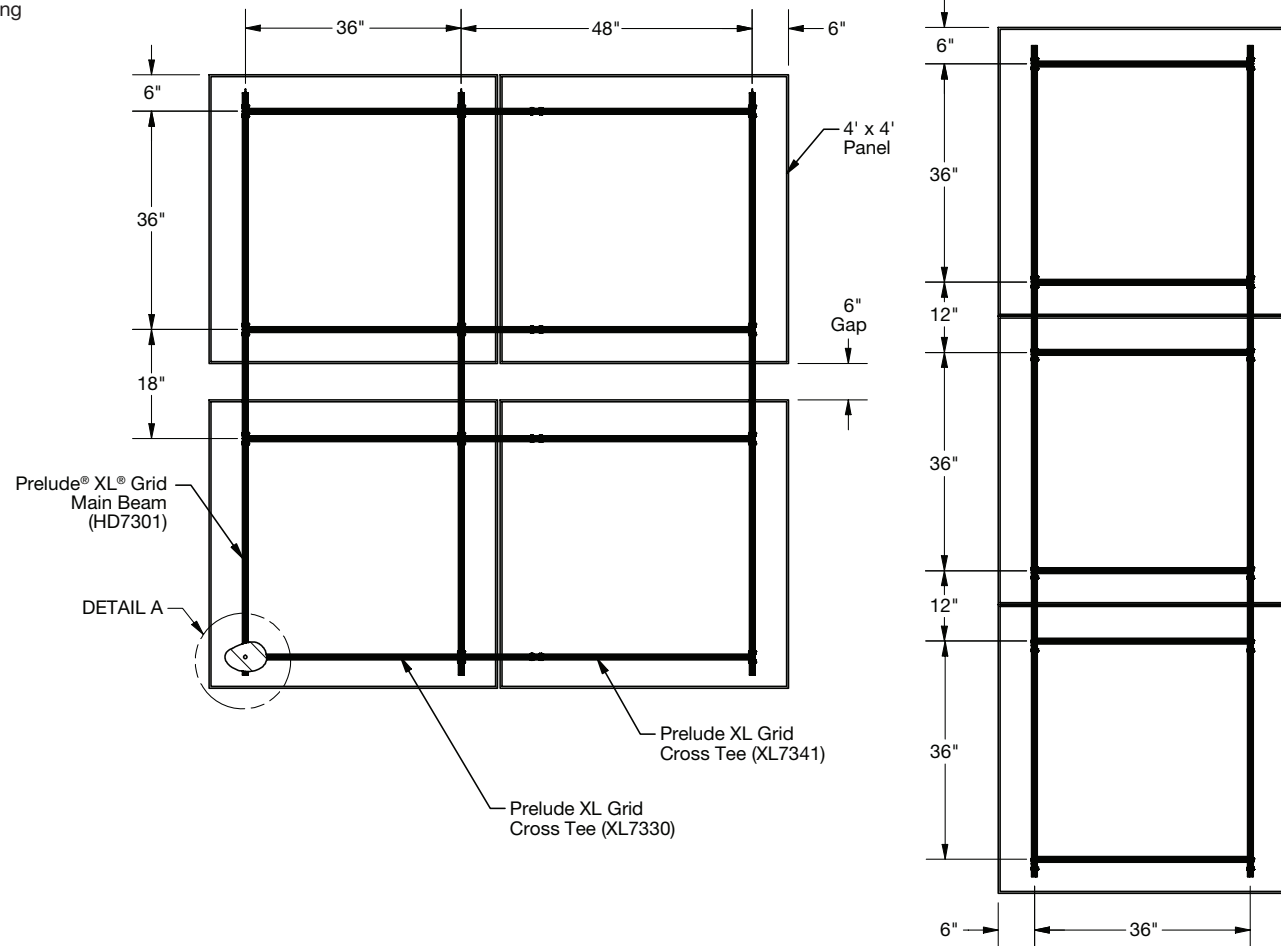
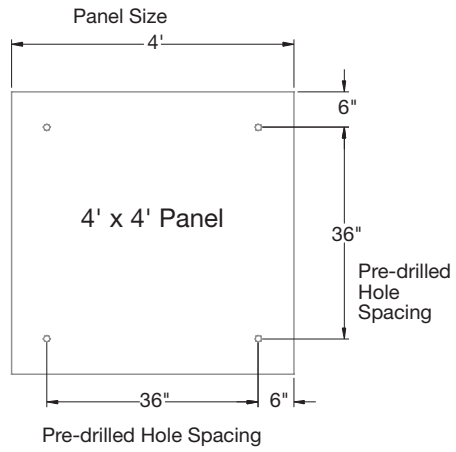

Grid Layout Example

2' x 6' Panel Layout

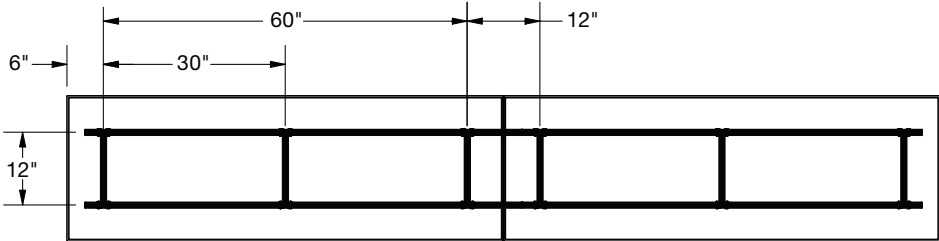
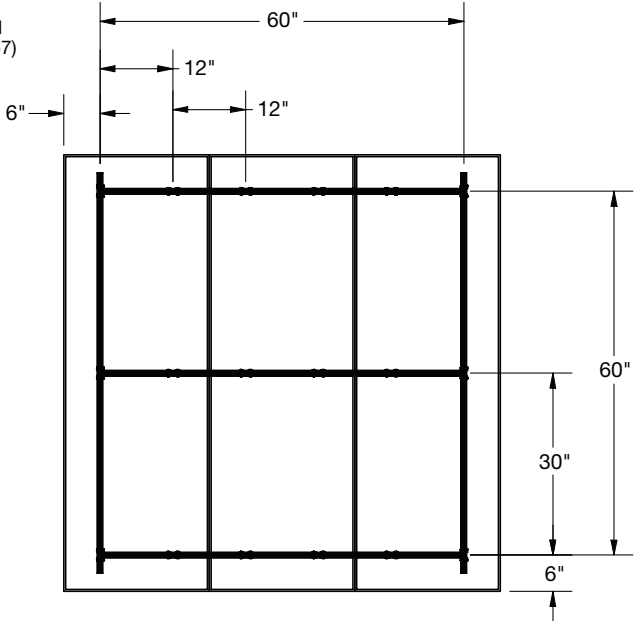
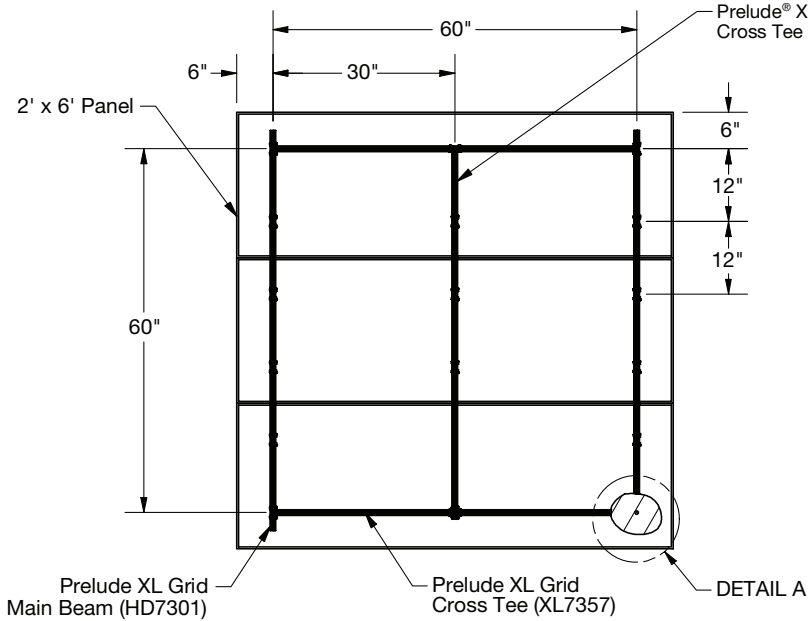
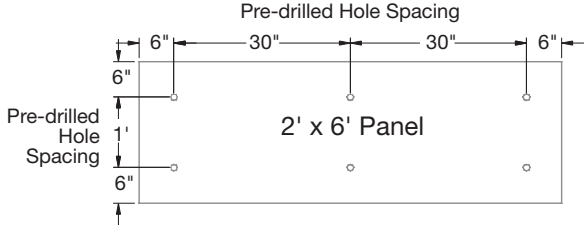

Capz™ Ceiling System Assembly

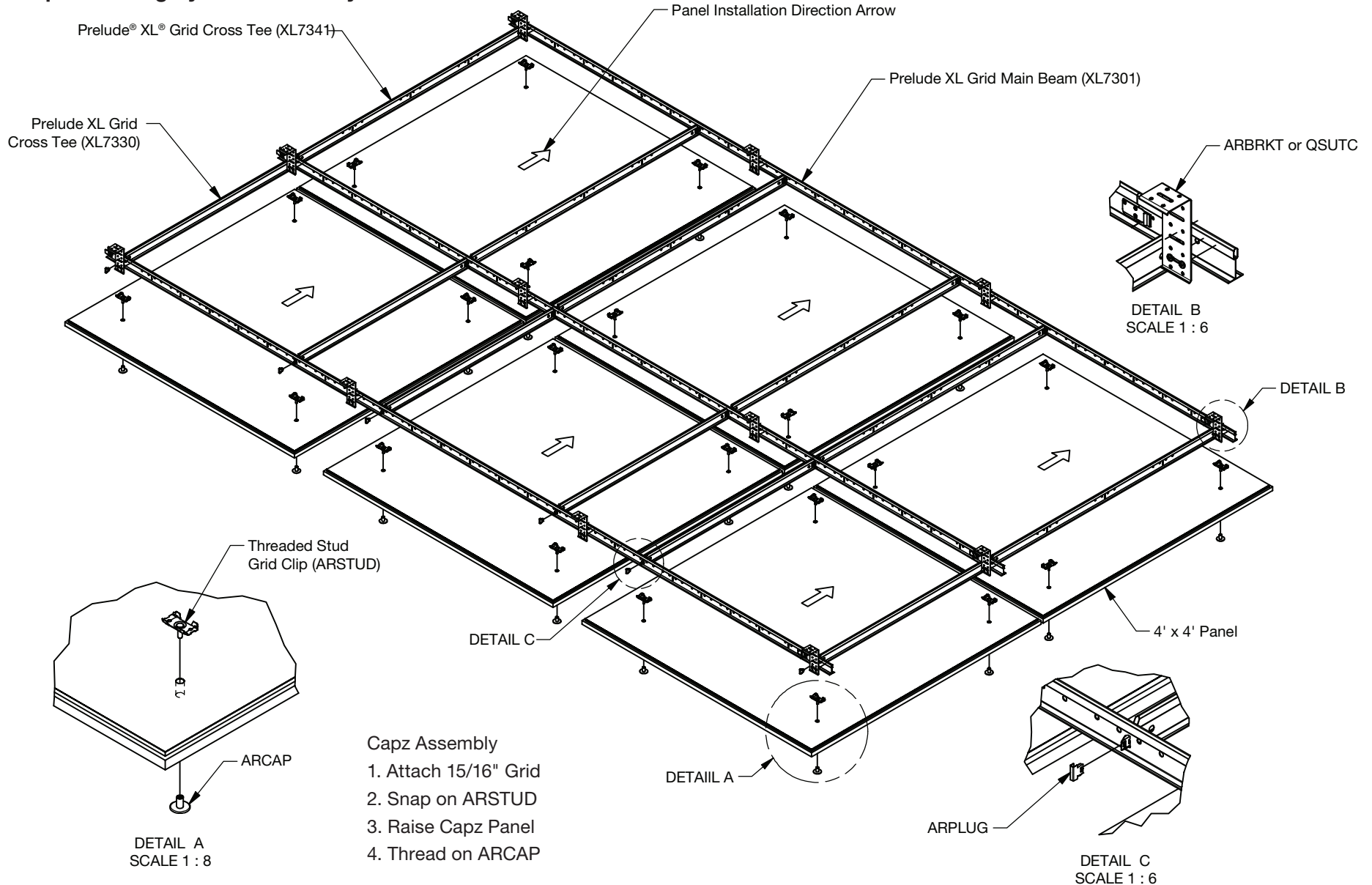

- Capz Assembly**
1. Attach 15/16" Grid
 2. Snap on ARSTUD
 3. Raise Capz Panel
 4. Thread on ARCAP

MORE INFORMATION

For more information, or for an Armstrong Ceilings representative, call 1 877 276-7876.
 For complete technical information, detail drawings, CAD design assistance, installation information, and many other technical services, call TechLine customer support at 1 877 276-7876 or FAX 1 800 572-TECH.
 For the latest product selection and specification data, visit armstrongceilings.com/capz

All trademarks used herein are the property of AWI Licensing LLC and/or its affiliates.
 © 2022 AWI Licensing Company Printed in the United States of America

BPLA-297435-1122

