

OPTIMA® and LYRA® Concealed

Assembly and Installation Instructions

1. GENERAL

Installed on the Heavy-duty Prelude® XL® 15/16" suspension system, Optima® and Lyra® Fully Concealed panels have a unique concealed edge. These panels offer an upscale, monolithic visual.

1.1 Product Description

The Optima and Lyra Concealed products referenced in these instructions are made from fiberglass. They are 100% downward accessible and can be removed without entering the plenum.

Optima and Lyra Concealed panels are designed with two support edges called Quick Kerf™ edges and two reverse Tegular non-support edges. The Quick Kerf edge allows one panel to lift up and slide behind the adjacent Quick Kerf edge for easy installation and removal. The reverse Tegular edges register the panel to maintain a consistent visual.

IMPORTANT NOTE: Walls or bulkheads surrounding the ceiling installation must be constructed and braced to limit lateral movement at the elevation of the ceiling to less than 1/4" under the loads anticipated. Where bracing is not possible, the perimeter closure element is to be detached from the wall surface and mechanically fastened to the ceiling suspension system (diaphragm). Additional support to structure will be needed to replace support which would have been provided through wall attachment.

1.1.1 Working with Fiberglass and Mineral Fiber Products

Precautionary Measures: During installation, be certain that the work site is well ventilated and avoid breathing dust. If high dust levels are anticipated during installation, such as with the use of power tools, use appropriate NIOSH designated dust respirator. All power cutting tools must be equipped with dust collectors. Avoid contact with skin or eyes.

First Aid Measures: If contact occurs, flush eyes and skin irritation with plenty of water for at least 15 minutes and remove contaminated clothing. Wash work clothes with warm water and mild soap.

Refer to Armstrong World Industries MSDS (which includes information on established occupational exposure limits), available at: armstrongceilings.com/commercial.

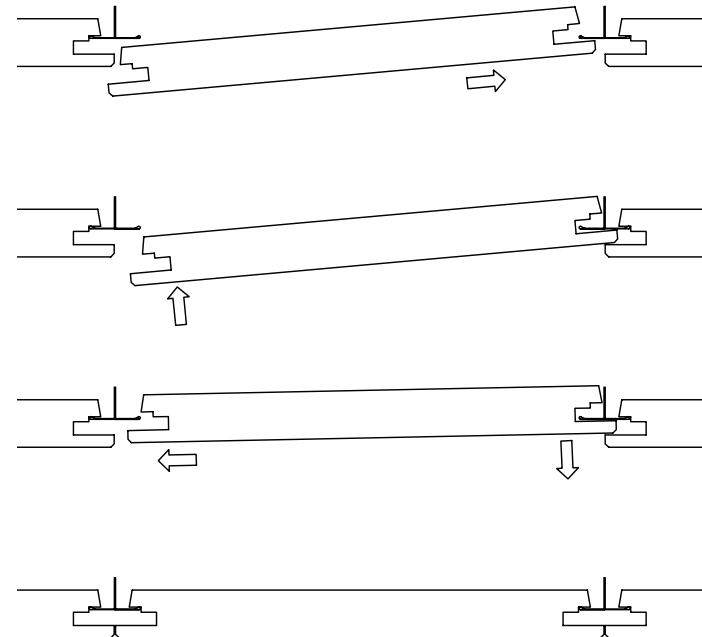

1.2 Surface Finish

The Armstrong® DuraBrite® surface of the Optima Concealed panels is scratch- and soil-resistant and washable. All panel edges are finished with a factory-applied paint.

Storage and Handling

Panels shall be stored in a dry interior location and remain in cartons in a flat position to avoid damage. Proper care should be taken when handling to avoid damage or soiling.

NOTE: Optima and Lyra Concealed edges are exposed when installed. Exercise care to avoid unnecessary contact with the panel edges. Suspension system flanges will not conceal panel edge damage, as the panel face extends below the face of the suspension system.

Protect Finished Edges – Do not stand the panels on edge. Keep them face-to-face, back-to-back, and flat on the work surface.

1.3 Site Conditions

Areas of installation shall be free of construction dust and debris. Products with HumiGuard® Plus performance can be installed in conditions between 32°F (0°C) and 120°F (49°C) and in spaces before the building is enclosed, where HVAC systems are cycled or not operating. These products are not recommended for exterior applications, or where standing water is present, or where moisture will come in direct contact with the ceiling.

1.4. Plenum

Installation of Optima® and Lyra® Concealed panels requires a minimum of 3" of space in the plenum to install the hanger wires for the suspension system. **NOTE:** Light fixtures and air handling systems require more space and will determine the minimum plenum height for the installation.

1.4.5 Independent support of MEP devices

There must not be weight from any lights, diffusers, speakers or similar devices supported by the Optima or Lyra Concealed panels or grid system. All such devices shall be independently supported.

1.5 Installation Rate

Full-size field panels install at approximately the same rate as Vector panels. Borders can be two to three times slower than typical installations.

1.6 Maintenance

Dust and loose dirt may easily be removed by brushing or with a vacuum cleaner. Vacuum cleaner brush attachments such as those designed for cleaning upholstery or walls do the best job. Be certain to clean in one direction only. This will prevent rubbing dust into the surface of the ceiling. Use a clean, dry, soft, white cloth to wipe off any dirt or greasy fingerprints. If this does not clean the panel, use a damp, clean, soft, white cloth or sponge with a mild detergent to wipe the panel. Remove any remaining moisture with a dry cloth.

1.7 Field Painting Precautions

Armstrong World Industries cannot guarantee that the published surface burning characteristics, fire resistance ratings, acoustical performance, dimensional stability/sag, or light reflectance will remain the same after repainting. Field painting panels upon installation will void the warranty.

1.8 Armstrong® SuperCoat™ Ceiling Panel Touch-up Paint – Items 5760 and 5761 White Latex Paint

SuperCoat Ceiling Panel Touch-up Paint is intended to hide minor scratches and nicks in the surface.

1.9 For Surface Scratch or Edge Damage

Use a small brush to apply paint to the affected area. Only apply paint to the damaged area with a dabbing motion to prevent getting excess paint on the finished area. Blend or feather the paint edges to the existing panel surface.

1.10 Directions for Applying #5761 Touch-up Paint

1. Remove loose dust from the material with a brush or vacuum cleaner attachment
2. Stir paint before and occasionally during use
3. Apply to damaged areas – avoid filling in scrim perforations
4. Quickly wipe off excess paint
5. Drying timing is approximately 30 minutes

2. GENERAL EXPLANATION OF EDGE DETAILS AND DESIGN CONSIDERATIONS

2.1 Quick Kerf™ Edge

The panel edge design has a stepped groove detail and is called the Quick Kerf edge. This edge is the first to engage the suspension system. It is located at opposite sides of the panel and will always be on the longer of the two sides (*Fig 1*).

2.2 Reverse Tegular Edges

The two remaining panel edges center the panel and are called reverse Tegular edges (*Fig 2*).

2.3 Mid-point Clips (item 523) Required for Reverse Tegular Edges on all Panels Per Diagram Below:

- Items 8538, 8539, 8434 – 48" x 48"

Mid-point clips are required for all panels with a width > 30" and where a Quick Kerf edge has been removed.

Use a Mid-point Clip at the middle of both reverse Tegular edges to support the panel on the suspension system flange. Gently push the clip into the edge as shown. When properly installed, the Mid-point clip will be flush with the back for field panels.

When installing a panel with Mid-point clips, first engage both Quick Kerf edges and then gently push up on the reverse Tegular edge at the location of each clip (*Fig 3*).

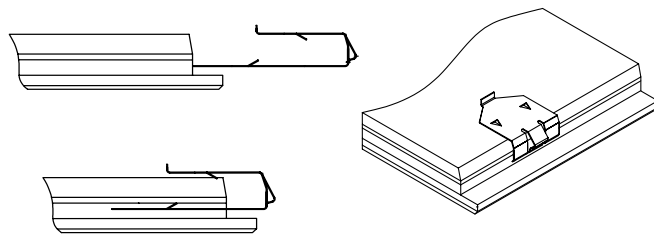

(Fig 3)

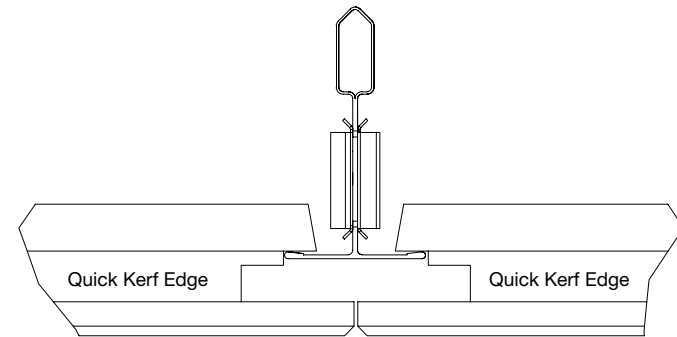
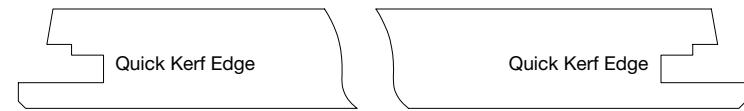

(Fig 1)

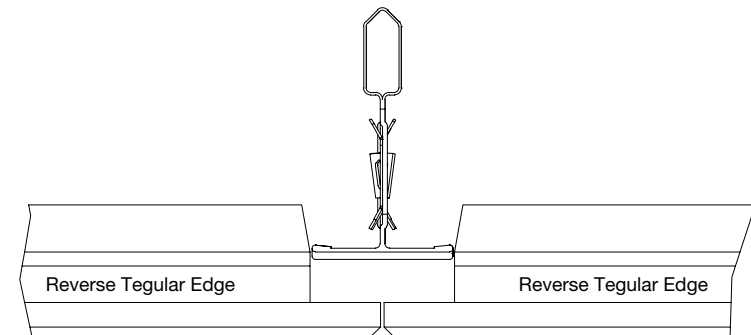
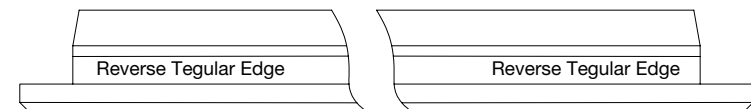

(Fig 2)

Gently push up on the reverse Tegal edges at the location of the Mid-point Clip to engage the clip on the suspension system flange (Fig 4).

2.4 Directionality

The concealed nature of this system makes the panels directional. The Quick Kerf™ edges on all panels should run the same direction in a space and will be reflected throughout this guide.

2.5 Panel Penetrations

Holes cut for sprinkler heads and other services that penetrate the ceiling panel must be cut slightly oval shaped to allow the panel to move 1/4" in the direction of the Quick Kerf edge. Additionally, trim rings for these devices must be wide enough to accommodate this 1/4" movement (Fig 5).

Most Optima® and Lyra® Concealed ceilings will be installed with penetrations through the panels such as sprinklers or "can" lights. Because the ceiling panels may not be in place when these penetrations are installed, the suspension system flange will be the installers' primary reference for ceiling plane height. The installers must be advised that **the actual ceiling plane will be lower than the suspension system flange height.**

Panel face offset extends 1/2" below the suspension system. The height of components that interface with the ceiling panels, such as sprinkler heads and light fixture trim rings, must be adjusted to accommodate this 1/2" offset.

2.6 Concealed Fixture Trim Kits (Fig 6)

CONCEALED FIXTURE TRIM:

4" – CTK4ZW Concealed Fixture Trim	48" – CTK48ZW Concealed Fixture Trim
6" – CTK6ZW Concealed Fixture Trim	72" – CTK72ZW Concealed Fixture Trim
24" – CTK24ZW Concealed Fixture Trim	96" – CTK96ZW Concealed Fixture Trim

2.6.1 General

The edge details on the Optima and Lyra Concealed product are designed so that each panel conceals half of the suspension system members. When two panels are adjacent to each other, a fully concealed visual is created. When integrating lighting and air diffusers into your Optima and Lyra Concealed layout, the use of a fixture trim kit is recommended to maintain a consistent visual (Fig 7).

2.6.2 Fixture Trim Kit Installation

Concealed Trim Kits are pre-mitered lengths of steel molding that snap onto the flanges of the grid with speed clips at the location of lay-in light fixtures or other accessories that sit in the suspension system. Concealed Trim Kits include 24 straight pieces and the required speed clips.

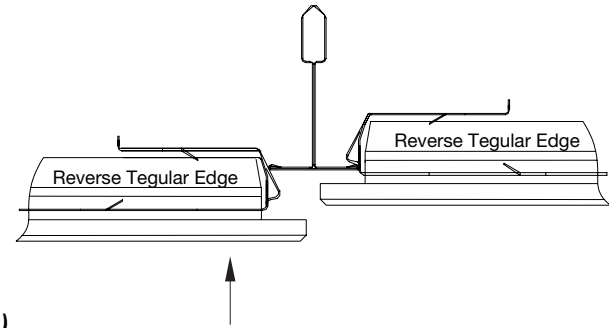

(Fig 4)

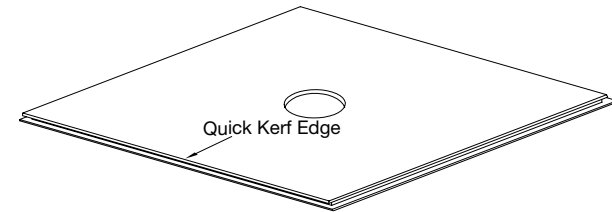

(Fig 5)

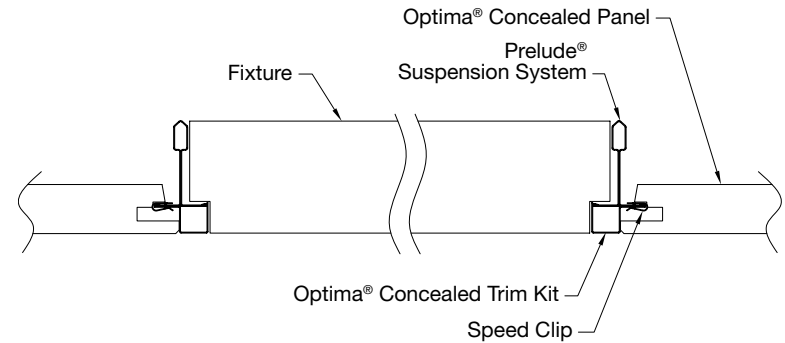

(Fig 6)

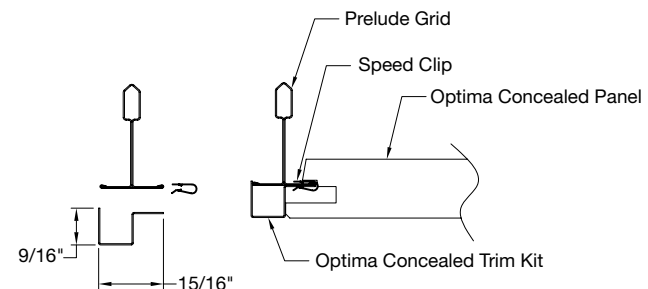

(Fig 7)

- The trim kits should be installed before installing the ceiling panels.
- Speed clips should be placed with the flat side on the top of the grid flange to allow the panels to sit properly.
- Speed Clips should be placed near the ends of each piece, then no more than 2' O.C. thereafter (2 clips per 4", 6", and 24" piece, 3 clips per 48" piece, 4 clips per 72", 5 clips per 96" piece).

NOTE: Full-size factory edges should be used with all fixture trim kits.

2.7 Accessibility

Border panels in a seismic installation will not be accessible. For a non seismic installation please refer to section 3.7.2 for creating accessible border ceiling panels.

3. SUSPENSION SYSTEM

3.1 General

Suspension system installation shall conform to ASTM C636 with the additional requirement listed in section 3.2 shall be Heavy Duty Prelude XL 15/16" suspension system, installed using not less than 12 gauge galvanized steel hanger wire (item 7891). All installations requiring 4' cross tees shall utilize XL7341 tees. Suspension system installation shall conform to ASTM C636 with the additional requirement listed in section 3.2.

3.2 Leveling Suspension System

IMPORTANT NOTE: The suspension system, whether new or existing, must be leveled to within 1/4" in 10' and must be square to within 1/16" in 2'. Installation on suspension systems that do not meet this tolerance will produce unacceptable panel alignment.

Do not attempt to install Optima® or Lyra® Concealed panels until the suspension system is properly squared. All 12 gauge hanger wires must be installed plumb to prevent grid rotation.

3.3 Installation Accessories

Installation accessories clips are not supplied with the panels and must be ordered separately.

The following clips are packaged in cartons of 50 pieces:

- Border Clip (item 441) – Required whenever a Quick Kerf edge must be removed from a field panel or corner panel.
- Hold Down Clip (item 442A) – Required for all installations of Optima Concealed, regardless of Seismic Design Category. The hold down clip will keep the panel tight in the suspension system, help maintain proper panel alignment, and prevent the panel from disengaging due to system movement or vibrations.
- Mid-point Clip (item 523) – Required to support the reverse Tegular edges of panels longer than 30" and all border panels.

The following clip is packaged in cartons of 1,000 pieces:

- Spring Border Clip (item 7870) – Used on installations with the panel resting on the wall molding.

3.4 Perimeter Suspension System Attached to Molding

BERC2/GCWA or stabilizer bars are required at the perimeters of all installations to stabilize cross tees and maintain proper panel alignment. Their use greatly improves ease of installation and removal of border panels.

- BERC2 – Beam End Retaining Clip
- GCWA – Grip Clip Wall Attachment

3.5 Stabilizer Bars in the Field (Required)

Stabilizer bars (item 7425) are required at the midpoint of all panels, and can be installed during suspension system installation. 24" (item 7425), 30" (Item 7431), and 48" (item 7445) bar sizes should be used depending on project conditions (*Fig 8*).

3.6 Concealed 442A Hold Down Clip Application

One Hold Down Clip (item 442A) is required for each panel. Clips should be applied to the suspension system before the installation of panels and should be located near the center of the Quick Kerf™ edge. Clips do not interfere with panel installation or removal (*Fig 9*).

Snap the clips onto the suspension system so they will press down on the Quick Kerf edge of all panels. A single clip at the midpoint is used for panels up to 48" long. For panels greater than 48" long, use an additional clip 12" from each end.

Do not install 442A Hold Down Clips on reverse Tegner edges. These edges are unsupported, and the pressure of the hold down clip will deform the plank and create a poor visual.

3.7 Perimeter Details (IBC Design A&B)

Molding items and accessories:

- Item 7875 – Shadow Molding
- Item 7800 – Angle Molding
- Item 7870 – Spring Border Clip
- Item GCWA – Grip Clip Wall Attachment
- Item 7425 – 24" Stabilizer Bar
- Item 7431 – 30" Stabilizer Bar
- Item 7445 – 48" Stabilizer Bars
- Item 441 – Border Clip

The suspension system is raised above the molding by 1/2". This clearance will allow the face of the panel to pass over and rest upon the support leg of the shadow molding, while the suspension system rests on the "step" of the shadow molding (item 7875). Stabilizer bars (preferred) or GCWA Grip Clips must be used to keep the suspension system openings from growing and the panels disengaging. Do not screw the GCWA Grip Clip to the wall angle since you may need to roll the cross tee for panel installation on two walls (*Fig 10*).

Install this strike panel much like you would a full-size panel. Use Mid-point Clips (item 523) on reverse Tegner edges along the border where the Quick Kerf edge has been removed or rest on the wall angle (two opposite sides of the space). Start with the cut edge going up and over the flange of the molding. Raise the panel up to horizontal and then slide the kerfed edge back onto the suspension system flange.

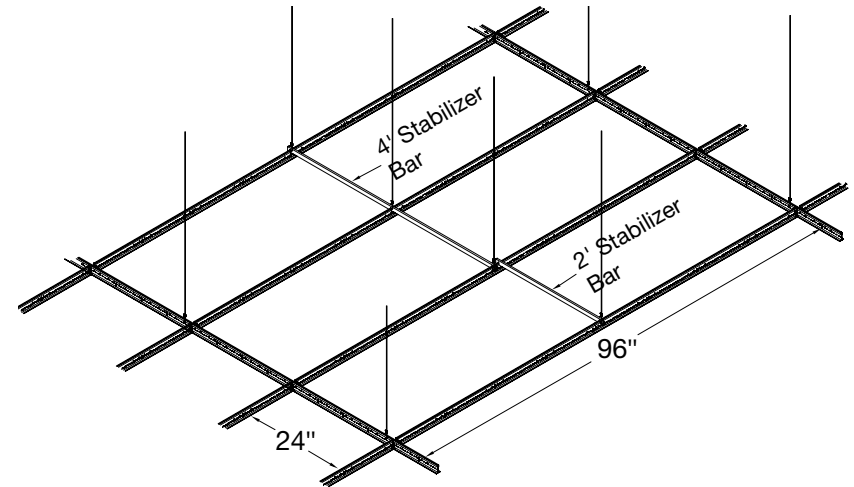

24" x 96" Panel Installation

(Fig 8)

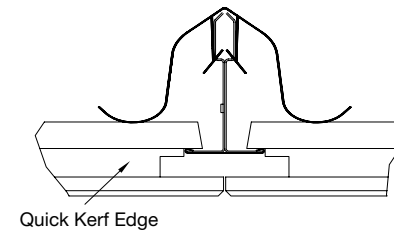

(Fig 9)

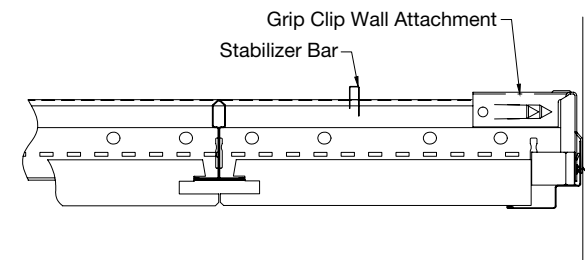

(Fig 10)

3.7.1 Shimming Border Panels

Insert a Spring Border Clip (item 7870) between the edge of the panel and the molding. This step is required to prevent the border panel from disengaging the suspension system flange and falling from the ceiling.

Border panels in a seismic installation will not be accessible. For a non seismic installation please refer to section 3.7.2 for creating accessible border ceiling panels (Fig 11).

3.7.2 Standard "L" or Shadow Molding Installations when Quick Kerf™ is Removed and Suspension System is Flush with the Angle

When this option is used, the cut is made parallel to the Quick Kerf edge of the panel. Support the cut side of the panel by inserting 441 Border Clips within 6" of the end and spaced 12" along the cut edge. This detail would only be used in non-Seismic Category A/B installations.

Use this method if you need access to the border panels (Fig 12).

3.8 Suspension System for Ibc Seismic Category (C, D, E, F)

3.8.1 General

The suspension system shall be Heavy-duty (IBC Design D) 15/16" exposed tee suspension system. The installation shall, in all cases, conform to the requirements of the International Building Code and its referenced standards:

- Walls or soffits that serve to support a panel edge must be braced to structure so as not to allow movement greater than 1/8" when subjected to design lateral force loads. When such bracing is not practical or is not effective, additional mechanically connected suspension system components shall be provided to capture all edges of every panel. Axiom® Perimeter Trim connected to the suspension system with Axiom T-Bar Connector clips (AXTBC) will also meet this requirement.
- The suspension system must be square.
- Hanger wires shall be installed not more than 48" O.C. along the length of the main beams.
- The suspension system must be leveled to within 1/4" in 10' and must be square to within 1/16" in 2'.

The requirements listed here represent the manufacturer's minimum acceptable installation recommendations, and may be subject to additional requirements established by the local authority having jurisdiction.

3.8.2 Seismic Suspension System Installation

Follow the Armstrong® Seismic Rx® ESR-1308 guidelines of installation for both IBC C & D installations. Seismic Rx installation method can be found in the Seismic Ceiling Installation Guide BPCS-4141.

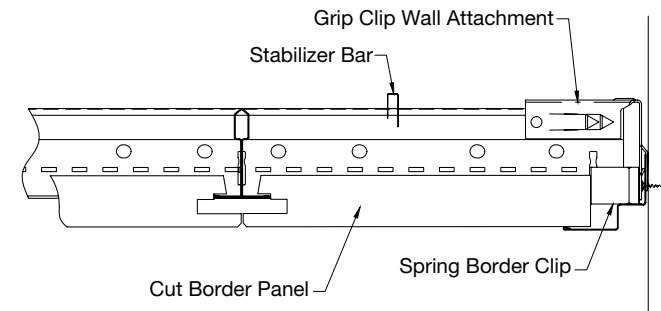

(Fig 11)

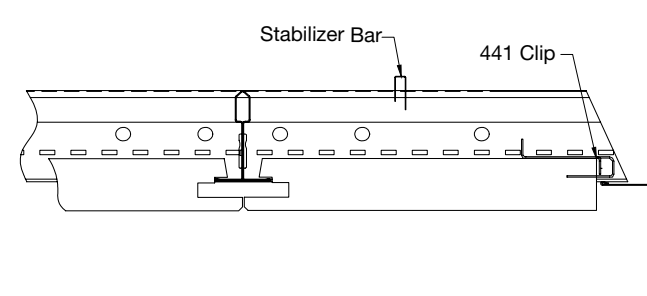

(Fig 12)

3.8.3 Perimeter Details (IBC Design C & D)

Molding items and accessories:

- Item 7897 – Seismic Shadow Molding
- Item 7870 – Spring Border Clip
- Item BERC2 – Beam End Retaining Clip

The suspension system is raised above the molding by 1/2". This clearance will allow the face of the panel to pass over and rest upon the support leg of the shadow molding, while the suspension system rests on the "step" of the shadow molding (item 7897). Do not screw attach the BERC2 clip to the molding, since you will need to roll the cross tee on two of the walls to install the border panel (**Fig 13**).

Install this panel much like you would a full-size panel. Use Mid-point Clips (item 523) on reverse Tegular edges along all the borders on a 48" x 48" system. All other sized panels where the Quick Kerf™ edge has been removed or rest on the wall angle (two opposite sides of the space) and Mid-point Clips (item 523) (not shown) will need to be added to the border panels only. Start with the cut edge going up and over the flange of the molding. Raise the panel up to horizontal and then slide the kerfed edge back onto the suspension system flange.

You may have to disengage the BERC2 clips from the back of the molding and reattach once the panels are installed. Start perimeters where the reverse Tegular side has been removed and work progressively around the room.

3.8.4 Shimming Border Panels

Insert a Spring Border Clip (item 7870) between the edge of the panel and the molding. This step is required to prevent the border panel from disengaging the suspension system flange and falling from the ceiling.

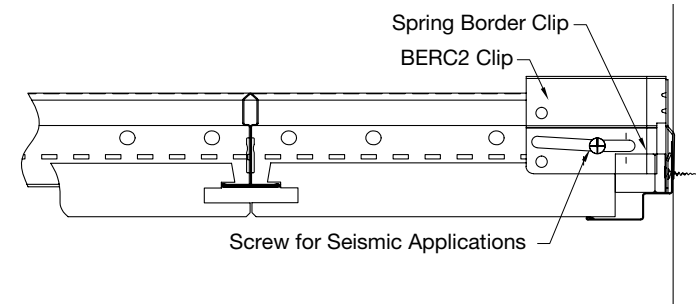

(Fig 13)

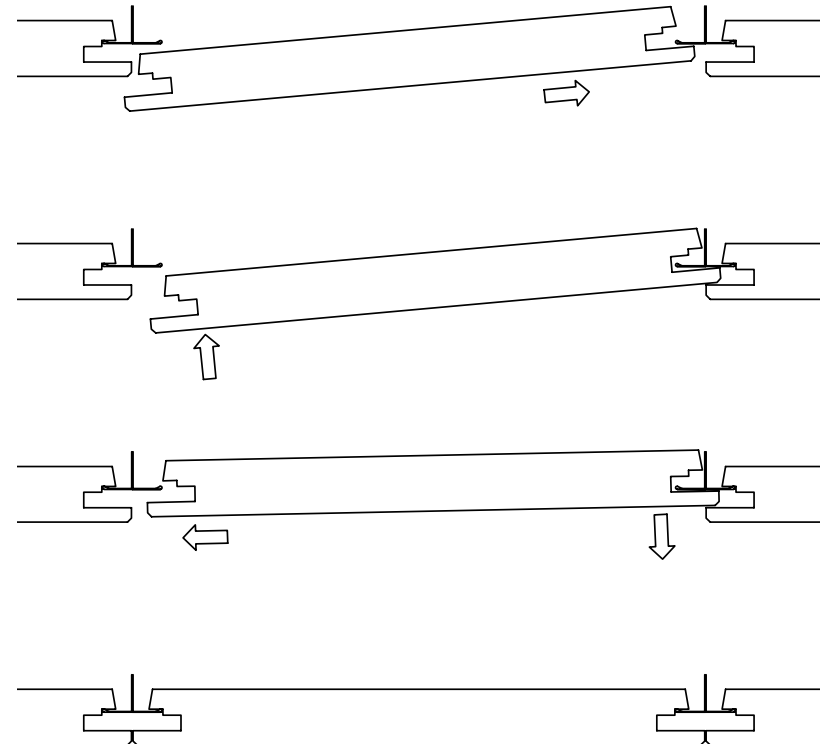

(Fig 14)

4. PANEL INSTALLATION AND REMOVAL

4.1. General

Concealed ceiling panels are easily installed and removed from below the suspension system without the aid of tools or special equipment, allowing easy downward access to the plenum.

NOTE: The use of two installers is recommended for 24" x 96" panels. This will ease the installation of the long kerfed edges and ensure proper fit into the suspension system.

4.2 Installing and Removing Full-size Panels (Fig 14)

4.3 Orientation of Full-sized Panels

Install all full-size panels with the Quick Kerf™ edge facing in the same direction to provide access consistency. Pay attention to this alignment process. Minor variations in placement can be difficult to see from the scaffold, but will become obvious when looking down long runs of panels.

4.4 Odd-size Panels – Field

Panels that are less than full size must be cut to replicate factory edges or ordered from Armstrong as a special size panel. This would be the recommended method for field panels.

- Removing a Quick Kerf edge will require a reverse Tegular edge to be created to support the cut Quick Kerf side of the panel by inserting Border Clips (item 441) within 6" of the end and spaced 12" along the cut edge to rest on the flange of the suspension system (*Fig 15*).
- If a reverse Tegular edge is removed in the field, it needs to be recreated but does not need additional support from Border Clips (item 441) (*Fig 16*).

4.4.1 Re-cut the Edge Detail

Turn the panel over and re-cut the reverse Tegular edge. Protect the face of the panel from damage.

4.4.2 Treating Field Cut Edges

All field cut edges "exposed to view" should be painted to match the factory finish. Armstrong® SuperCoat™ Ceiling Panel Touch-up Paint (items 5760 and 5761) is recommended. Allow the paint to skin over before installing the panels.

Use a larger 1" wide brush to apply the touch-up paint to the cut edge. Apply a liberal amount of paint to the brush and coat several inches of the cut edge. For best results, use as few strokes as possible to cover the area. Avoid getting paint on the face of the panel and wipe off any excess as soon as possible. Paint will dry in approximately 30 minutes.

5. MEP AND AXIOM® DETAILS

Interfacing with Axiom® Vector® trim (full size) (*Fig 17*).

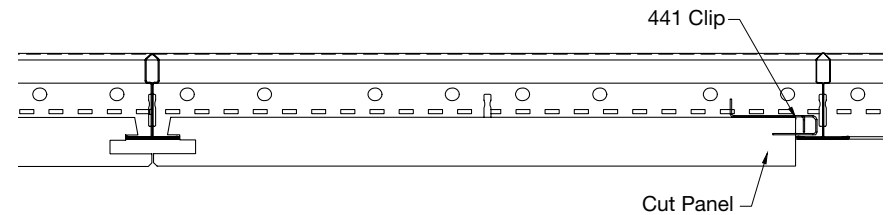

(Fig 15)

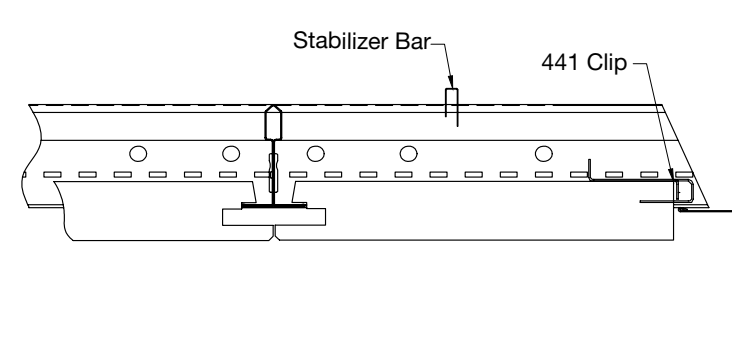

(Fig 16)

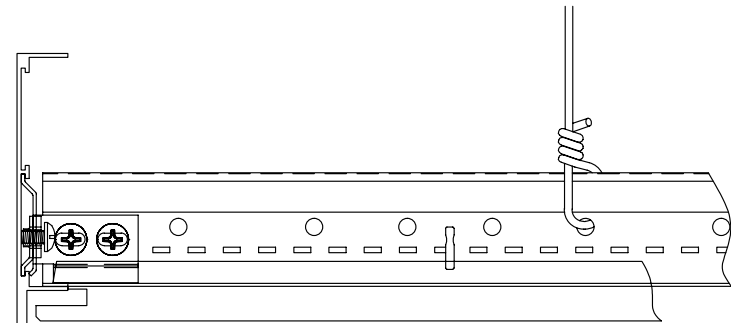

(Fig 17)

CEILING PANEL ITEMS:

Optima® PB Concealed

8537 – 24 x 48 x 7/8"

8535 – 24 x 72 x 7/8"

8536 – 24 x 96 x 7/8"

8534 – 30 x 30 x 7/8"

8538 – 48 x 48 x 7/8"

8539 – 48 x 48 x 7/8"

(with foil back)

Lyra® Concealed

8430 – 30 x 30 x 7/8"

8433 – 24 x 48 x 7/8"

8431 – 24 x 72 x 7/8"

8432 – 24 x 96 x 7/8"

8434 – 48 x 48 x 7/8"

Other sizes – W: 4" – 30" / L: 12" – 96",
W: >30" – 48" / L: 12" – 48", 7/8" Thick

CEILING PANEL ACCESSORIES:

441 – Border Clip

442A – Hold Down Clip

7425 – 24" Stabilizer Bar

7431 – 30" Stabilizer Bar

7445 – 48" Stabilizer Bar

7870 – Spring Border Clip

523 – Mid-point Clip

BERC2 – Beam End Retaining Clip

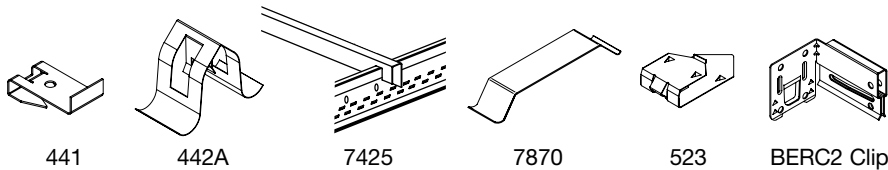

MORE INFORMATION

For more information, or for an Armstrong Ceilings representative, call 1 877 276-7876.

For complete technical information, detail drawings, CAD design assistance, installation information, and many other technical services, call TechLine customer support at 1 877 276-7876 or FAX 1 800 572-TECH.

All trademarks used herein are the property of AWI Licensing LLC and/or its affiliates.
© 2021 AWI Licensing Company Printed in the United States of America

BPLA-298368-621

Armstrong®
CEILING & WALL SOLUTIONS