

Prelude® XL Max® Suspension System – Data Center Ceiling Solutions

Assembly and Installation Instructions

Hardware to be Purchased Separately

Screws are fine listed as shown:

- Min 1-1/4" or longer #8 Truss head self-tapping screws for attaching structural wall angle, lateral support bar 16" or 24" O.C. to structure
- #8 truss head self-tapping screw 1/2" to secure XTAC clips to the structural wall angle
- #8 truss head sharp point screw 1/2" long for the top lock clips and for PMLC clips
- Blind Steel Pop Rivets, 1/8" Dia. x .337" Long, .126" – .186" Grip Range, Shear Strength: 260 lbs.
- 3/8" Threaded Rod for Connections to Structure
- Blind Steel Pop Rivets 3/16" Diameter for installation of the TLMBS

SYSTEM OVERVIEW

1.1 Product Description

The Prelude® XL Max® Suspension System is designed to offer flexible and reconfigurable support of cable trays, bus bars, hot aisle containment, and other hanging elements via 3/8" threaded rod connections to structure. The diagram below provides an overview of the suspension system components, clips, and accessories.

NOTE: These panels are specially sized and engineered for Prelude® XL Max® and must be used with the system. These panels do not fit in other suspension systems.

Full-size panels may be required in installations that do not use load-carrying clips, as these clips reduce the grid opening size. Alternatively, a shim can be added next to the panel to help keep it centered within the opening.

IMPORTANT: The Prelude® XL Max® Load Connector item PMLC is designed to be used with Prelude® XL Max® Suspension System only. They are designed for specific duty loads that are specified in the load charts provided on the last page of this document. When hanging heavy loads greater than those specified in the load charts, consultation by a local engineer is required. Also, please be sure to review the installation and securing recommendations for any load that will be supported by the suspension system. Armstrong is not liable for improper use or improper installation of the Prelude® XL Max® Suspension System or its components.

Please refer to the load charts for specific information on the allowable loads for the suspension system.

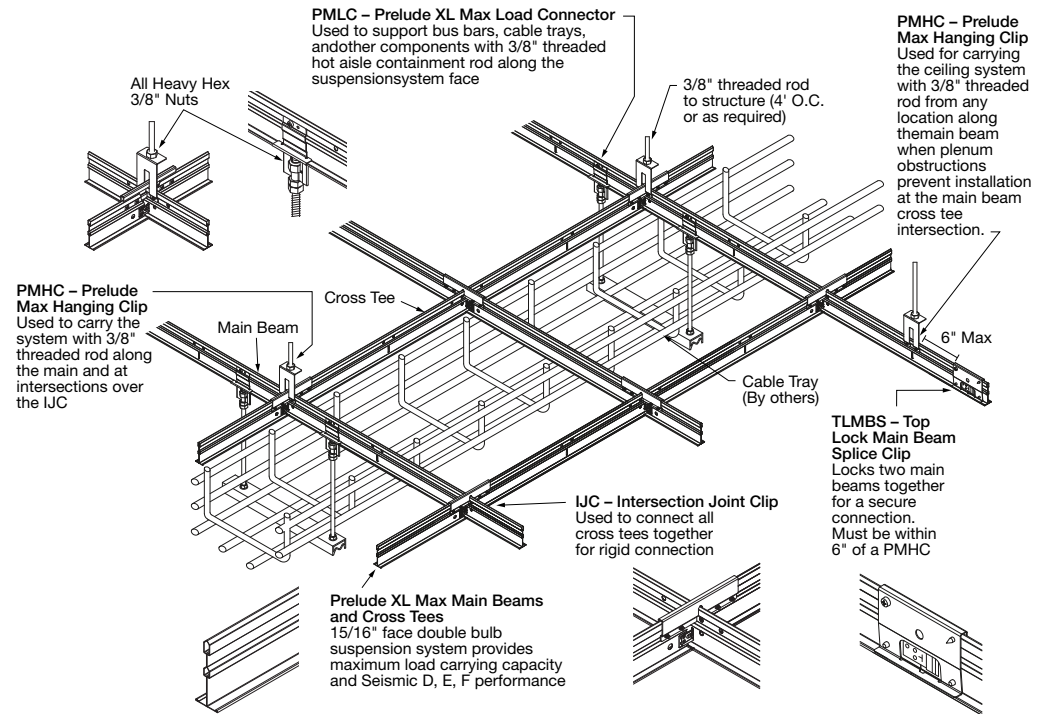

INSTALLATION CONSIDERATIONS

The Prelude® XL Max® Suspension System is designed to be installed with 3/8" threaded rod from structure. However, you may find it easier to hang and level the suspension system first, using standard 12 gauge hanger wire before replacing all hanger wire with 3/8" threaded rod.

2.1 Lay out the space, marking the locations of the hanger rods, main beams, and cross tees, and note any mechanicals that will be supported overhead. Be sure to follow the locations and direction of the threaded rod, hangers, main beams, cross tees of the engineering drawing if working from a Reflected Ceiling Plan from a specifying architect/engineer. If plumb threaded rod drops are not possible, then a trapeze or sub framing may be required. This sub or trapeze framing must be engineered to support the designed loads. You may also reference our trapeze chart in our Technical Guide.

2.2 Install the Structural Wall Angle item SWA9878HRC. Screw attach structural wall angle to studs or structure 16" or maximum 24" on center, with #8 truss head, self-tapping screws. All cross tees and main beams are to be connected to the structural wall angle with an XTAC Clip, using two steel pop rivets.

IMPORTANT: Rivets are properly installed when the compressed rivet body protrudes a minimum of 1/8" past the XTAC surface.

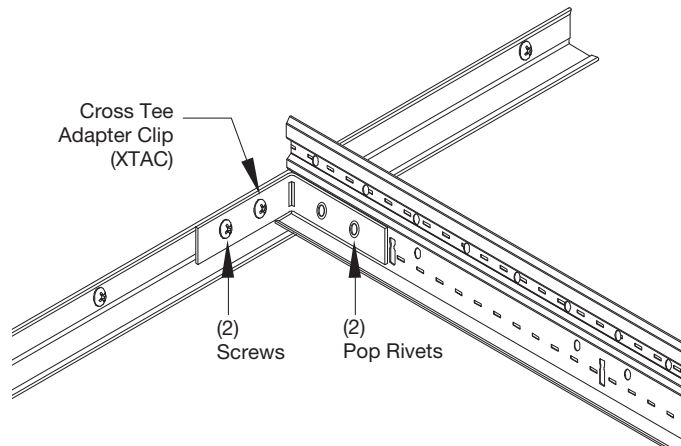

Fig 1

2.2.1 In seismic installations requiring free-floating connections, Lateral Support Bars (LSB) shall be installed to support perimeter cross tees and main beams in place of connections to the structural wall angle with an XTAC clip. In addition to allowing free-floating connections, the Lateral Support Bar also serves as a stabilizer bar keeping perimeter components from spreading apart. The LSB eliminates the need for perimeter support wires and 2" wall angle molding. To install, slide the lower leg of the Lateral Support Bar over the top bulb of each cross tee and main beam that require the free-floating connection (as shown in the detail below). Screw attach the upper leg of the Lateral Support Bar to wall studs or structure at maximum 24" O.C., with #8 truss head, self-tapping screws. The Lateral Support Bar must be screw attached to the wall before the placement of lay-in panels.

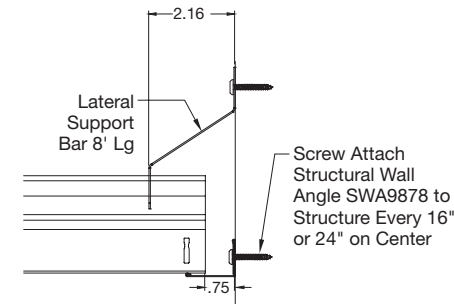

Fig 2

3. Mark the locations of the main beams and cross tees on the wall angle.
4. Install 3/8" threaded rod hangers into the deck per the recommendations from the deck anchor manufacturer. Threaded hanger rods must be installed plumb with the Prelude Max Hanging Clip (PMHC) in all main beam-to-cross tee intersections 4' O.C., unless otherwise specified.

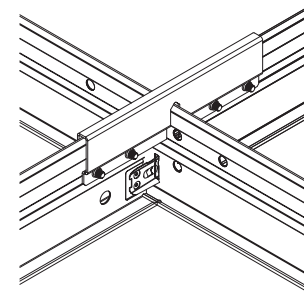

Fig 3

- Insert the PMHC over the main and install M5 machine screws into holes through main and into the PMHC. Set the torque to a low torque on the drill motor for this process.

NOTE: Clips must be replaced if any screws are stripped out.

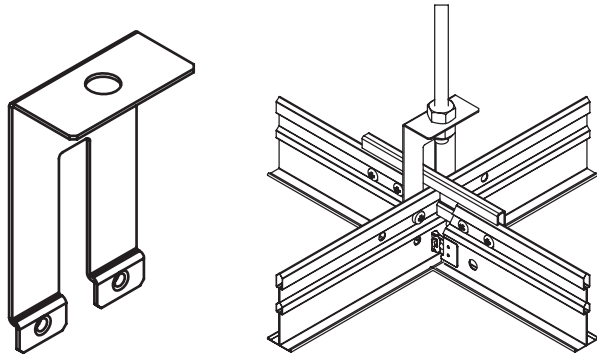

Fig 4

PMHC – Prelude Max Hanging Clip

- Thread the nut on the threaded rod per the installation detail. Tighten the 3/8-16" nuts until metal to metal contact is made and then turn an additional 1/4 turn with a wrench. Use all hardware provided with the PMHC. Threadlocker is required and has been pre-applied for ease of install.

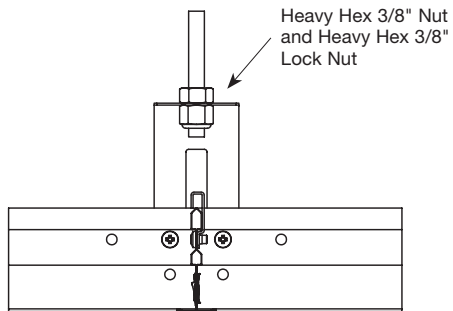

Fig 5

PMHC – Prelude Max Hanging Clip

- Install the cross tees as they would be installed on any standard suspension system.

- On every main beam-to-cross tee intersection and every 4' cross tee-to-2' cross tee intersection, you must install an Intersection Joint Clip (IJC). The IJC is used to connect all tees together structurally. Attach the IJC to the cross tees using four M5 machine screws and thread locker adhesive as shown below (Included with IJC; do not substitute). All IJCs running in the same line of grid need to be in the same orientation; facing the same direction. This will allow for easier ceiling panel installation.

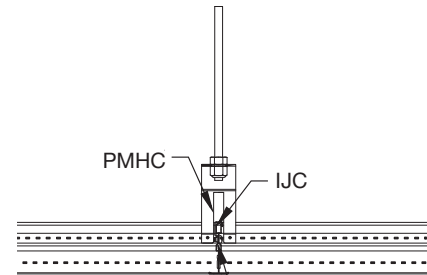
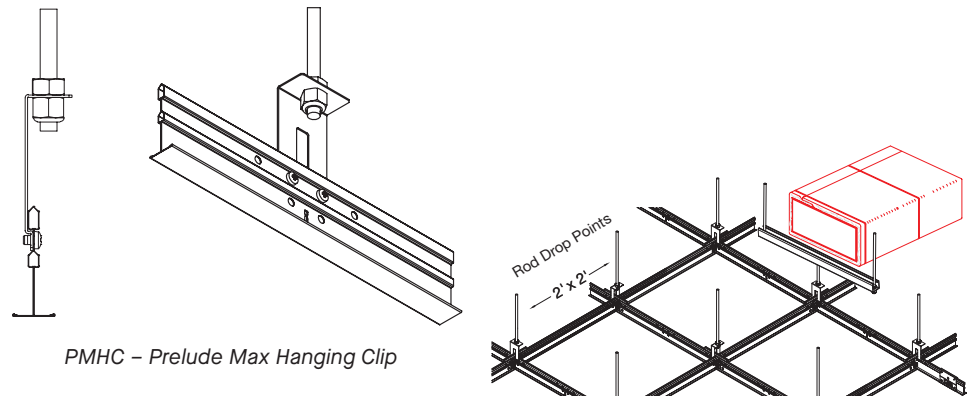

Fig 6

Prelude XL Max
4' Cross Tee

NOTE: New rod location must be carefully located so that the new span does not exceed allowable limit per engineer.



PMHC – Prelude Max Hanging Clip

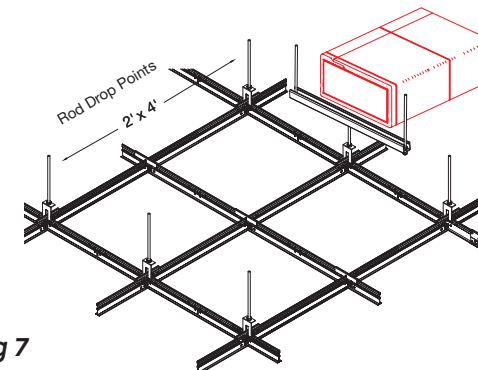

Fig 7

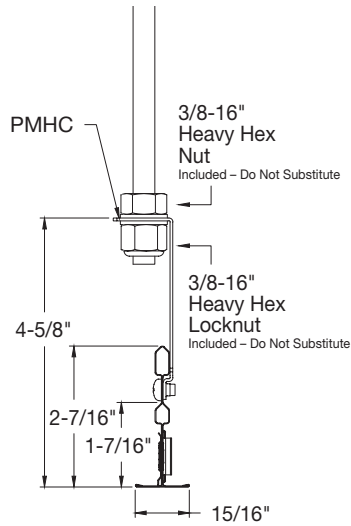

Fig 8

8. When a desired location for the threaded rod to structure cannot be achieved at intersections (due to obstructions in the plenum), the Prelude Max Hanging Clip (PMHC) can be used in other locations along the length of the mainbeam. All PMHC clips need to be installed in the same direction, orientation as described above.

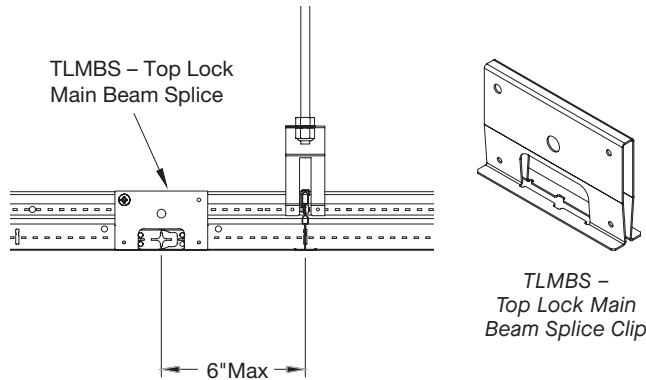

Fig 9 Top Lock Main Beam Splice Clip Installation on two Prelude® XL Max® Main Beams

9. Install the Top Lock Main Beam Splice (TLMS) onto each main beam coupling to secure the connection using two #8 truss head sharp point screws and two blind 3/16" steel pop rivets as shown in the detail below. Two holes must be drilled in the main beam to accommodate the two blind rivets. The Top Lock Main Beam Splice is required at every main beam splice location in the field of the installation.

IMPORTANT: To ensure rated load capacity, the threaded rod to structure must be installed within 6" of TLMS as shown in the image above.

IMPORTANT: Rivets are properly installed when the compressed rivet body protrudes a minimum of 1/8" past the TLMBS surface.

NOTE: For rivet installation, installer must drill 3/16" holes through grid once the TLMBS is located. For rivet installation the installer must clamp the TLMBS in position, then drill the 3/16" holes through the grid. With the clamp still in place, pop-rivet the TLMBS and main beam connection.

10. For perimeter treatment, rods must be located within 2' off the wall to carry 15lb/SFT. Spacing of the threaded rods can be increased if 15lb/SFT isn't needed for the data center layout. Consult your engineer and the Technical Guide for more information.
11. Once all the main beams and cross tees are installed, verify that all connections on the Prelude Max Hanging Clip (PMHC) are tight and a thread locking compound was used before proceeding with the installation. A locking compound is not required, if using a locknut per the illustration on the PMHC connection.
12. Locate the positions of the mechanical equipment (cable trays, bus bars, etc.) that are to be supported and attach the Prelude® XL Max® Load Connector (PMLC) to the face of the suspension system. Slide the clip open and engage it on the face of the suspension system. Be sure the two halves of the clip fully engage the clip around the flange of the suspension system and are interlocked together.

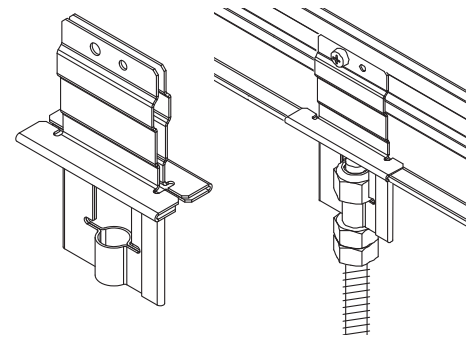

Fig 9

PMLC - Load Connector Clip

13. Screw the Prelude® XL Max® Load Connector (PMLC) clip to the suspension system using a #8 truss head sharp point screw as shown above. Be sure to screw from the larger hole (the pilot hole) into the smaller hole of the other clip. Only one screw is required to properly install the PMLC. Install the threaded rod that will be used to support the load using the provided hardware as shown in the detail bottom left. Hand tighten nuts 1 & 2 until metal to metal contact is made and then turn an additional 1/4 turn with a wrench. Then hand tighten nut 3 to nut 2 until metal to metal contact is made and then turn an additional 1/4 turn with a wrench. A thread locking compound is required for this connection if you do not use a locknut as shown in the detail above. Do not use standard 3/8" nuts.

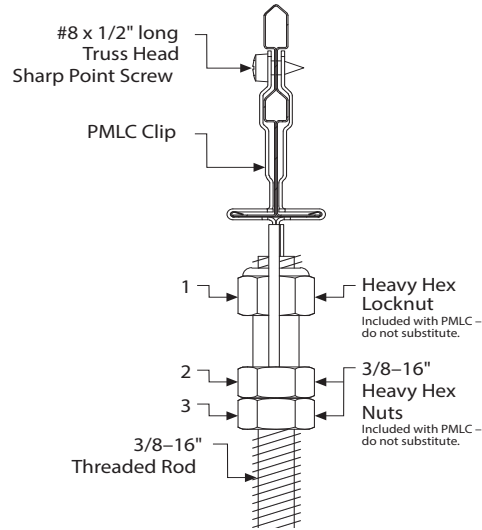

Fig 9 Load Connector Clip Installation

14. Install the ceiling panels – Please see BPCS-4933 Prelude® XL Max® Data Page for coordinating ceiling panels.

NOTE: These panels are specially sized and engineered for Prelude® XL Max® and must be used with the system. These panels do not fit in other suspension systems. Full-size panels may be required in installations that do not use load-carrying clips, as these clips reduce the grid opening size. Alternatively, a shim can be added next to the panel to help keep it centered within the opening.

IMPORTANT: The Prelude® XL Max® Load Connector item PMLC is designed to be used with Prelude® XL Max® Suspension System only. They are designed for specific duty loads that are specified in the load charts provided on the last page of this document. When hanging heavy loads greater than those specified in the load charts, consultation by a local engineer is required. Also, please be sure to review the installation and securing recommendations for any load that will be supported by the suspension system. Armstrong is not liable for improper use or improper installation of the Prelude® XL Max® Suspension System or its components.

15. If your project requires the Maximum Hold Down Clips, these will be installed in a progressive layout. Leave one panel unclipped for access to the plenum space, and then install the clips progressively from this panel. If there is a specific area of the plenum that will require more access, leave this as your unclipped panel. If access to other panels is needed, remove the clips in reverse order in which they were installed.

Seismic Data

IBC categories D, E and F must also meet these additional requirements:

- Structural wall angle is to be used along the perimeter with a XTAC clip attaching the grid to the angle molding, as directed in section 2.
- Grid must be attached to two adjacent walls –opposite walls must have a 3/4" clearance in accordance with ASTM E580.
- Ends of main beams and cross tees must be tied together to prevent their spreading. These should be locked into place using the lateral support bar.
- Ultra Heavy-duty grid system. See load data.
- Ceiling areas over 1,000 SF must have standard rigid bracing for the grid.
- Ceilings without rigid bracing must have 2" oversized trim rings for sprinklers and other penetrations.
- Changes in ceiling plane must have positive bracing.
- Mechanicals (Cable trays, electrical, etc) may be attached and supported by the ceiling grid, per our instructions. However, mechanicals must be seismically braced by others.
- Suspended ceilings will be subject to special inspection.

NOTE: Consult your local code professional for information specific to your region. California projects may be governed by DSA and OSHPD.

Prelude® XL Max® Load Connector – Max Single Point Loads

NOTES: These values are based on the spans being installed in a 2' x 2' module (using a 2' tee). Unbraced or 2' x 4' modules will have a lower mid span load value. For additional loading configurations, contact Techline for guidance and a qualified engineering professional.

Cross Tee, 4' Span

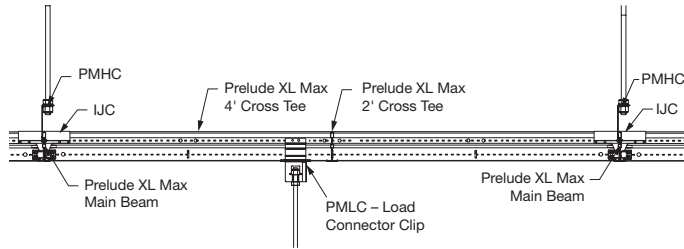

Max mid span load = 93 lbs
Max point load within 3" of threaded rod = 300 lbs

Main Beam, 4' Span

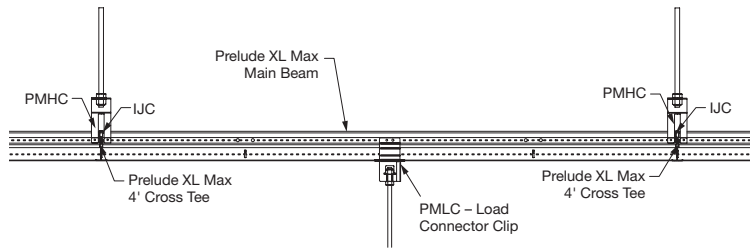

Max mid span load = 93 lbs
Max point load within 3" of threaded rod = 300 lbs

MORE INFORMATION

For more information, or for an Armstrong Ceilings representative, call 877 276-7876. For complete technical information, detail drawings, CAD design assistance, installation information, and many other technical services, call TechLine customer support at 877 276-7876.

All trademarks used herein are the property of AWI Licensing LLC and/or its affiliates.

© 2026 AWI Licensing Company Printed in the United States of America

BPLA-298020-326



Armstrong[®]
World Industries