

SOUNDSOAK® Acoustical Baffles

Assembly and Installation Instructions

1.0 GENERAL

1.1 Product Description

Soundsoak® Baffles with fiberglass core are available standard in a 24" x 48" size with fabric and sailcloth finish options. Baffles use either a grommet or eye hook for attachment or suspension from structure. 24 x 48 x 2" baffles have an eye hook and 24 x 48 x 1-1/2" baffles have a grommet. Baffles are not to be cut or field modified during installation.

Additional colors, sizes, and edge details are available as custom options; contact Architectural Specialties at 1 877 276 7876, select options 1-1-4.

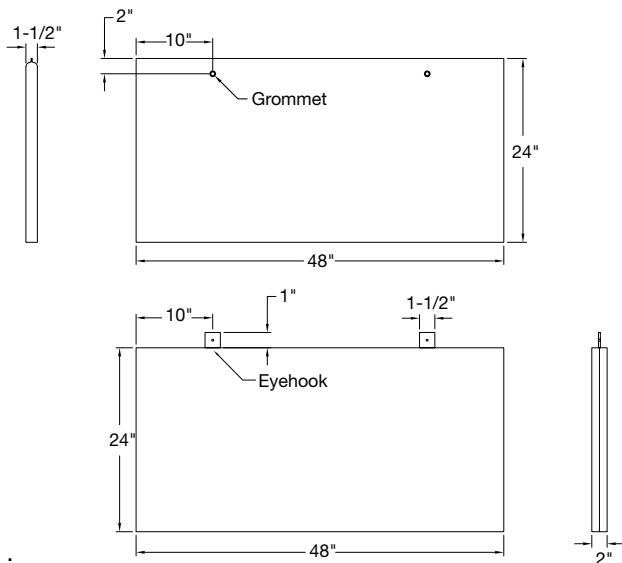

1.2 Materials and Finishes

Soundsoak Baffles are available with a rigid fiberglass core encased in fabric or nylon. There are 22 standard fabric color options and 8 sailcloth options for the finished panels.

1.3 Storage and Handling

The ceiling components shall be stored in a dry interior location and shall remain in original cartons prior to installation to avoid damage. The cartons shall be stored in a flat, horizontal position. Proper care should be taken to locate the hardware packet immediately upon opening the carton and to save the top carton lid for use during installation as a guide for hanging the canopies. The panels should not be removed from their carton and the plastic film and protectors around the panels should not be removed until installation is complete. Proper care should be taken when handling to avoid damage and soiling.

1.4 Precautionary Measures: During the installation, be certain that the work site is well ventilated and avoid breathing dust. If high dust levels are anticipated during installation, such as with the use of power tools, use appropriate NIOSH designated dust respirator. Avoid contact with skin or eyes. Wear long-sleeve, loose fitting clothes, gloves, and eye protection.

1.5 Temperature and Humidity During Installation

The product can be installed up to 100°F (38°C). It cannot be used in exterior applications, where standing water is present, or where moisture will come in direct contact with the baffle.

Installation must not be carried out in areas in excess of 90% RH. Following practical completion, conditions must be maintained below 70% RH.

1.6 Fire Performance

Soundsoak Baffles, as with other architectural features located in the ceiling plane, may obstruct or skew the existing or planned fire sprinkler water distribution pattern, or possibly delay the activation of the fire sprinkler or fire detection system. Designers and installers are advised to consult a fire protection engineer, NFPA 13, and their local codes for guidance on the proper installation techniques where fire detection or suppression systems are present. Contact TechLine at 1-877-276-7876, option 1, then 2, then 3, for specific U.S. and Canadian fire performance data.

2.0 Installation

Soundsoak Baffles are installed using tie wire or aircraft cable with options for various plenum conditions.

2.1 Baffle Hanging Kit – Fully Suspended

Soundsoak® Baffles can be independently suspended using the Baffle Hanging Kit (item #5670). Each kit contains two 8-1/16" aircraft cables, two carabiners, and two quick release adjusters.

Determine the location to hang the baffles. Fasten an appropriate anchor to the structure. You must have a hole to loop the aircraft cable through the anchor. Slip the quick release adjuster onto the cable.

Next, thread the end of the cable back into the other end of the adjuster to secure the cable loop onto the anchor. Adjust the elevation of the cable carabiner to be at the top of the baffle. To release the cable, take all weight off the adjuster, use your thumb to pull the side release tab down, and simply slide the cable out as needed. For baffles with a fiberglass core, snap the carabiner into the baffle grommet or eye hook. If needed, adjust the elevation using the quick release adjuster to level. For baffles with a BioAcoustic™ core, install with the cable and adjuster attached to the baffle and the carabiner to the anchor.

NOTE: Cable kit can be installed reversed. Cinch the loop end of the cable to the anchor and loop the cable with adjuster through the carabiner. Snap the carabiner to the baffle grommet or eye hook.

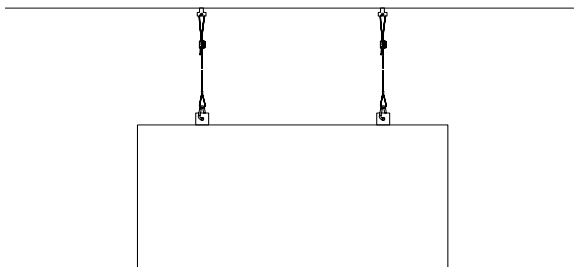

2.2 Attach to Bar Joists – Parallel

Soundsoak Baffles can be wire tied directly to the top or bottom of bar joists. These baffles will be parallel to the bar joists. Baffles attached at the top will hang beside the joist. Baffles attached at the bottom will hang below the joist. Thread the tie wire through the grommet or eye hook and then around the bar joist. Twist the wire to complete the connection.

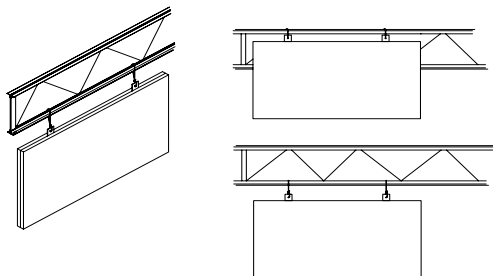

2.3 Attach to Bar Joists – Perpendicular

Soundsoak Baffles can be installed perpendicular to the bottom of bar joists. Install a tight cable support system (by others) for baffle attachment. Secure anchors at both ends into the wall. Attach the cable, thread the cable above the lower bar of the joists, and use a turnbuckle to tighten the cable. For long runs of cable or wide spacing of bar joists, additional vertical cable support may be required. Attach the baffle to the cable with tie wire. Tie wire connection should be snug to the cable to minimize baffle slippage.

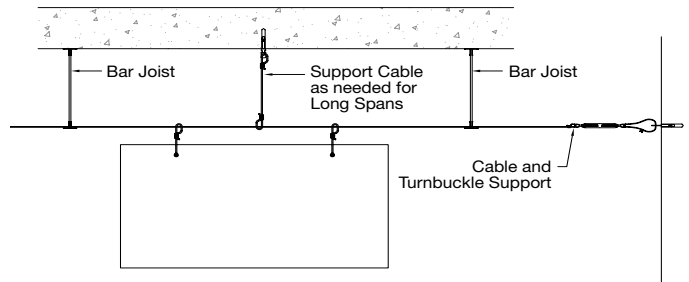

2.4 Direct to Structure

Attach the appropriate anchor to structure. Thread the tie wire through the grommet or eye hook in the baffle. Next, thread the tie wire through the hole in the anchor. Twist the wire to complete the connection. Do not overtighten the wire or put excessive force on the grommet, as this may cause baffle failure. Tie wires should be plumb. Avoid wires at angles that cause stress to the grommet or eye hook.

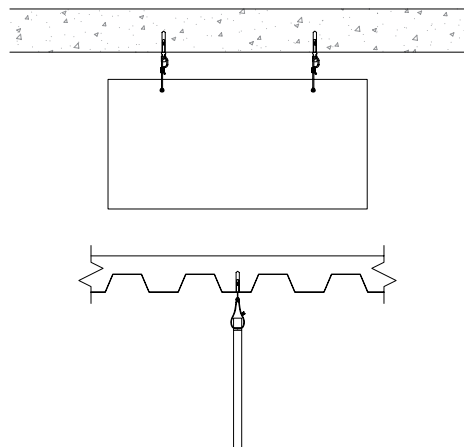

3.0 Seismic Restraint and Installation

The International Building Code allows architectural components to swing freely as long as they will not be damaged or cause damage. Baffles suspended will swing no more than 18" in any direction for each panel. Restraint of baffles is not recommended.*

**Pendulum reaction information is based on full-scale testing and computer modeling conducted at the Structural Engineering Earthquake Simulation Lab located at the State University of New York at Buffalo.*

4.0 Cleaning Instructions

Woven fabrics are colorfast to both water-based and solvent-based cleaning solutions and may be cleaned with all conventional upholstery cleaning systems.

Note that the following are general recommendations for the panel fabric only. Some fabric cleaning methods may cause damage to underlying materials in panel or wall panel systems. Contact the panel manufacturer for recommendations and precautions prior to attempting any of the following procedures:

1. Vacuum the fabric periodically to remove accumulated dirt and dust. The frequency of this and any other routine maintenance is determined by end use conditions.
2. Blot fresh spills immediately.
3. Ensure that the fabric is adequately rinsed after cleaning, as residual cleaning agents may accelerate soiling.
4. Have the fabric professionally cleaned whenever large stains or an overall soiled condition occurs.

For most water-based stains, a clean, absorbent cloth dampened with a detergent solution (e.g., 1 teaspoon laundry detergent/1 pint warm water) should be applied to the stain. Blot the fabric with the treated cloth, working from the outer edge of the stained area moving inward. In order to effectively draw out the stain, renew the cleaning cloth frequently. Rinse well with clear water, and dry the fabric as quickly as practical. Oil-based stains may be treated in a similar manner, substituting a volatile solvent-based cleaner for the detergent solution. Always follow the manufacturer's recommendation for using such products, and always pretest an inconspicuous area of the fabric for colorfastness to the cleaning agent.

For sailcloth fabrics, common dirt and stains may be removed by rubbing lightly with a moistened cloth, sponge, or soft bristle brush using a mild soap, detergent, or non-abrasive cleanser. It is important that clean water be used on a constant basis and that the material be towel dried.

MORE INFORMATION

For more information, or for an Armstrong representative, call 1 877 276 7876.

For complete technical information, detail drawings, CAD design assistance, installation information, and many other technical services, call TechLine customer support at 1 877 276 7876 or FAX 1 800 572 TECH.

For the latest product selection and specification data, visit armstrongceilings.com/blades

Inspiring Great Spaces® is a registered trademark of AFI Licensing LLC.

All other trademarks used herein are the property of AWI Licensing LLC and/or its affiliates.

© 2018 AWI Licensing LLC • Printed in the United States of America

BPLA-297749-1218

