

OPTIMA[®], ULTIMA[®], CALLA[®], and LYRA[®] Vector[®]

Assembly and Installation Instructions

1. GENERAL

Installed on standard Prelude[®] XL[®] 15/16" suspension system, Vector[®] panels have a unique edge detail providing a 1/4" reveal. When installed properly, they offer an upscale, monolithic appearance.

1.1 Product Description

The Vector[®] products referenced in these instructions are made from fiberglass or mineral fiber. All are 100% downward accessible and all full panels can be removed and reinstalled without entering the plenum.

Two sides support installed panels. These edges have specially designed kerf details, which allow one edge of the panel to be raised slightly off of the suspension system flange and then moved out of position. The other two sides have reverse Tegular edges, which center the panel in the suspension system.

IMPORTANT NOTE: Walls or bulkheads surrounding the ceiling installation must be constructed and braced to limit lateral movement at the elevation of the ceiling to less than 1/4" under the loads anticipated. Where bracing is not possible, the perimeter closure element is to be detached from the wall surface and mechanically fastened to the ceiling suspension system (diaphragm). For additional details, contact our Techline team. Additional support to structure will be needed to replace support which would have been provided through wall attachment.

1.1.1. Working with Fiberglass & Mineral Fiber Products

Precautionary Measures: During the installation, be certain that the work site is well ventilated and avoid breathing dust. If high dust levels are anticipated during installation, such as with the use of power tools, use appropriate NIOSH designated dust respirator. All power cutting tools must be equipped with dust collectors. Avoid contact with skin or eyes.

First Aid Measures: If contact occurs, flush eyes and skin irritation with plenty of water for at least 15 minutes and remove contaminated clothing. Wash work clothes with warm water and mild soap.

Refer to Armstrong[®] Ceilings MSDS (which includes information on established occupational exposure limits), which are available from Armstrong World Industries (AWI).

1.1.2. Installation Accessories

Accessories are not supplied with the panels and must be ordered separately.

These clips are packaged in cartons of 50 pieces.

- Ultima[®] Vector[®] Border Clips (item 440) – Required whenever two edges must be removed from a panel, most commonly for corner panel installation. These clips are used on projects using perimeter option B.
- Optima[®] and Lyra[®] Vector[®] Border Clips (item 441) – Required whenever two edges must be removed from a panel, most commonly for corner panel installation. These clips are used on projects using perimeter option B.
- Calla[®] Vector[®] Border Clips (item 443) – Required whenever two edges must be removed from a panel, most commonly for corner panel installation. These clips are used on projects using perimeter option B.
- Vector Hold Down Clips (item 442A) – Required for use for all installations of Ultima, Optima, Calla, and Lyra Vector, regardless of Seismic Design Category. The hold down clip will keep the panel tight in the suspension system, help maintain proper panel alignment, and prevent the panel from disengaging due to system movement or vibrations.
- Mid-Point Clips (item 522) – Required to support the “C” and “D” edges of Optima Vector and Ultima Vector panels longer than 30".
- Mid-Point Clips (item 523) – Required to support the “C” and “D” edges of Calla Vector panels equal to or greater than 30".

- Spring Border Clips (item 7870) – Used on installations with the panel resting on the wall molding, perimeter option A.
- Stabilizer Bars (items 7425, 7431, 7445) – Used at borders to limit movement of grid in the absence of perimeter clips (BERC2, GCWA) or Axiom® trim clips (AXTBC, AXVTBC). Required throughout the field of the installation for 2' x 8' panels.
- Vector® Trim Kits – Used to trim out full-module fixtures or accessories that sit in the suspension system. Vector Trim Kits are made from pre-mitered lengths of steel molding that snap onto the flanges of the grid with speed clips. They are available in different lengths and packaged in quantities of 24 pieces per carton, with the speed clips included.

Protect Finished Edges

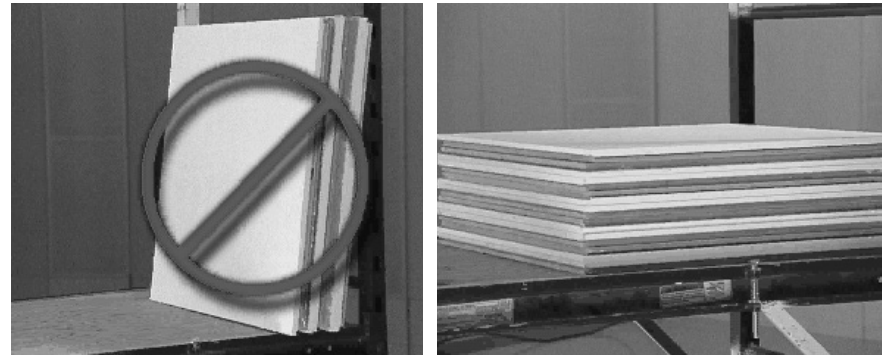

Do not stand the panels on edge.

Keep them face-to-face, back-to-back and flat on the work surface.

(Fig 1)

1.2. Surface Finish

The Armstrong® DuraBrite® surface of Ultima® and Optima® panels is scratch- and soil-resistant and washable. The panel edges are finished with a factory-applied paint. Calla®, Lyra®, and Optima panels have square edges. Ultima panels have beveled edges. Optima items 3901, 3903, and 3905 have CAC foil backing.

1.3. Storage and Handling

Panels shall be stored in a dry interior location and remain in cartons in a flat position to avoid damage (Fig 1). Proper care should be taken when handling to avoid damage or soiling.

NOTE: Vector panel edges are exposed when installed. Exercise care to avoid unnecessary contact with the panel edges. Suspension system flanges will not conceal panel edge damage, as the panel face extends below the face of the suspension system (Fig 2).

1.4. Site Conditions

Areas of installation shall be free of construction dust and debris. Products with HumiGuard® Plus performance can be installed in conditions between 32°F (0°C) and 120°F (49°C) and in spaces before the building is enclosed, where HVAC systems are cycled or not operating. These products are not recommended for exterior applications, or where standing water is present, or where moisture will come in direct contact with the ceiling.

1.5. Plenum

Installation of Vector panels requires a minimum of 3" of space in the plenum to install the hanger wires for the suspension system.

NOTE: Light fixtures and air handling systems require more space and will determine the minimum plenum height for the installation.

Avoid Damaging Finished Edges

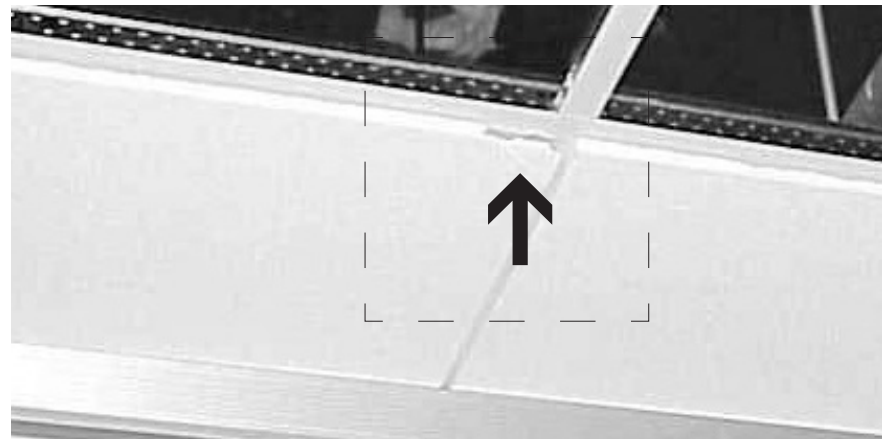

(Fig 2)

1.6 Installation Rate

Field panels install at approximately the same rate as Tegular panels. Depending on border installation methods, borders could be 2 to 3 times slower than Tegular borders.

1.7 Maintenance

Dust and loose dirt may easily be removed by brushing or with a vacuum cleaner. Vacuum cleaner brush attachments such as those designed for cleaning upholstery or walls do the best job. Be certain to clean in one direction only. This will prevent rubbing dust into the surface of the ceiling. Use a clean, dry, soft, white cloth to wipe off any dirt or greasy fingerprints. If this does not clean the panel, use a damp, clean, soft, white cloth or sponge with a mild detergent to wipe the panel. Remove any remaining moisture with a dry cloth.

1.8 Field Painting Precautions

AWI cannot guarantee that the published surface burning characteristics, fire resistance ratings, acoustical performance, dimensional stability/sag, or light reflectance will remain the same after repainting. Field painting panels upon installation will void the warranty.

1.9 Armstrong SuperCoat™ Ceiling Panel Touch-up Paint – Items 5760 and 5761 White Latex Paint

SuperCoat Ceiling Panel Touch-up Paint is intended to hide minor scratches and nicks in the surface.

1.10 For Surface Scratch or Edge Damage

Use a small brush to apply paint to the affected area. Only apply paint to the damaged area with a dabbing motion to prevent getting excess paint on the finished area. Blend or feather the paint edges to the existing panel surface.

1.11 Directions for Applying #5761 Touch-up Paint

1. Remove loose dust from the material with a brush or vacuum cleaner attachment
2. Stir paint before and occasionally during use
3. Apply to damaged areas – avoid filling in scrim perforations
4. Quickly wipe off excess paint
5. Drying timing is approximately 30 minutes

2. GENERAL EXPLANATION OF EDGE DETAILS

2.1 Access Vector Kerf Edge (“A” Kerf)

The panel edge designated as “A” has a stepped groove detail and is called the access kerf. This edge is the first to engage the suspension system. An arrow printed on the back of the panel will identify this edge (*Fig 3*).

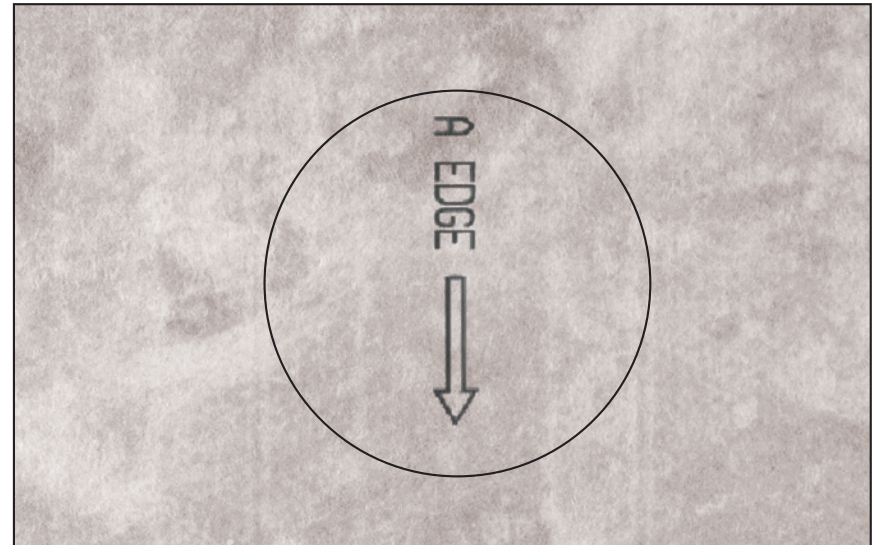

(Fig 3)

2.2 Registration Kerf (“B” Kerf)

Edge “B” has a single kerf detail that supports the second side and centers the panel in the “A - B” direction. This edge is referred to as the registration kerf and is opposite edge “A” (Fig 4).

2.3 Reverse Tegular Edges

The two remaining panel edges center the panel in the “C - D” direction and are called reverse Tegular edges (Fig 5).

2.3.1. Mid-Point Clips (MPC) Required for “C” and “D” edges of Vector® Panels:

- Mid-Point Clip – Item 522 – Optima Vector Item 3909 – 48" x 48"
- Mid-Point Clip – Item 523 – Calla Vector Item 2813 – 30" x 30"
- Made-to-order sizes ≥ 30 " in length

Use a Mid-Point Clip at the middle of both “C” and “D” edges to support the panel on the suspension system flange. Rest the bottom of the clip on top of the “C” or “D” edge and gently push the clip into the edge as shown (Fig 6).

Once the A and B edges are engaged in the grid, gently push up on the “C” and “D” edges at the location of the Mid-Point Clip to engage the clip on the suspension system flange (Fig 7).

3. SUSPENSION SYSTEM

3.1 General

The suspension system shall be Prelude® XL® or existing 15/16" intermediate-duty or heavy-duty grid, installed using no less than 12 gauge galvanized steel hanger wire (item 7891). Suspension system installation shall conform to ASTM C636 requirements.

3.2 Leveling Suspension System

The suspension system, whether new or existing, must be leveled to within 1/4" in 10' and must be square to within 1/16" in 2'. Installation on suspension systems that do not meet this tolerance will produce unacceptable Vector® panel alignment. Do not attempt to install Vector panels until the suspension system is properly squared (Fig 8).

3.3 Stabilizer Bars – Perimeter Clips

- Item 7425 – 24" Stabilizer Bar
- Item 7431 – 30" Stabilizer Bar
- Item 7445 – 48" Stabilizer Bar
- BERC – Beam End Retaining Clip
- BERC2 – Beam End Retaining Clip
- GCWA – Grip Clip Wall Attachment

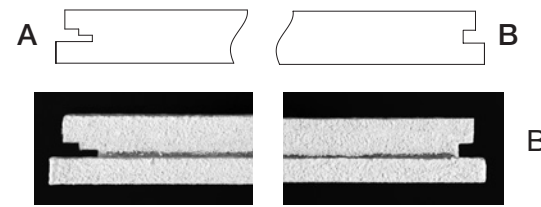

(Fig 4)

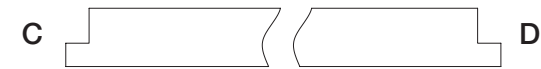

(Fig 5)

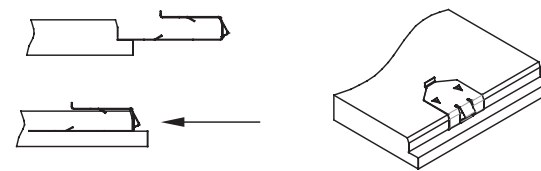

(Fig 6)

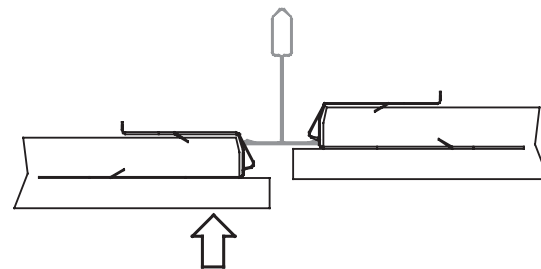

(Fig 7)



(Fig 8)

3.4 Stabilizer Bars at Perimeter

Stabilizer bars or BERC/BERC2/GCWA Clips are recommended at the perimeters of all installations to stabilize cross tees and maintain proper panel alignment. Their use greatly improves ease of installation and removal of border panels.

3.5 Stabilizer Bars in the Field (item 3907)

Stabilizer bars are required at the midpoint of all panels over 5' in length for the entire installation, and can be installed during suspension system installation. 24", 30", and 48" sizes are available depending on project conditions (Fig 9).

3.6 Vector Hold Down Clip Application

Vector Hold Down Clips (item 442A) are required for all Vector panels regardless of Seismic Design Category. Clips should be applied to the suspension system before the installation of panels and should be located near the center of the kerfed edges.

All "A" edges must have Vector Hold Down Clips. Clips do not interfere with panel installation or removal (Fig 10).

Snap the clips onto the suspension system so they will press down on the "A" edge of all panels. A single clip at the midpoint is used for panels up to 48" long. Panels greater than 48" long use a clip 12" from each end.

Do not install Vector Hold Down Clips on "C" or "D" edges. These edges are unsupported, and the pressure of the hold down clip will deform the plank and create a poor visual.

3.7. Panel Penetrations

Holes cut for sprinkler heads and other services that penetrate the ceiling panel must be cut slightly oval shaped to allow the panel to move 1/4" in the direction of the "A" edge. Additionally, trim rings for these devices must be wide enough to accommodate this 1/4" movement (Fig 11).

PENETRATIONS THROUGH VECTOR® CEILINGS

Most Vector ceilings will be installed with penetrations through the panels such as sprinklers or "can" lights. Because the ceiling panels may not be in place when these penetrations are installed, the suspension system flange will be the installers' primary reference for ceiling plane height. The installers must be advised that THE ACTUAL CEILING PLANE WILL BE LOWER THAN THE SUSPENSION SYSTEM FLANGE HEIGHT.

PANEL FACE OFFSET

The face of Optima®, Ultima®, Calla®, and Lyra® Vector panels extend 1/2" below the suspension system. The height of components that interface with the ceiling panels, such as sprinkler heads and light fixture trim rings, must be adjusted to accommodate this 1/2" offset (Fig 12).

3.7.1 Proper Penetration Installation (Fig 13)

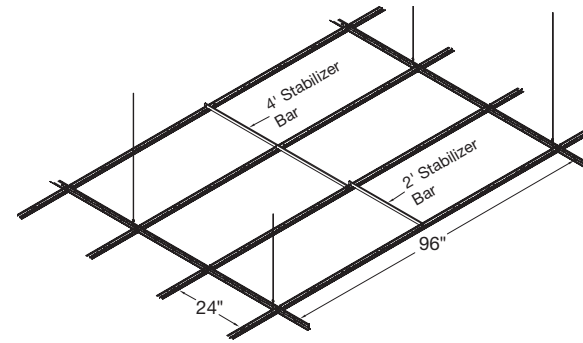

24" x 96" Panel Installation

(Fig 9)

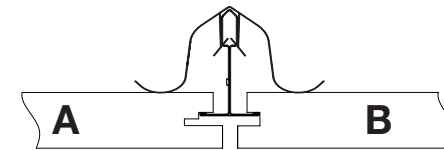

(Fig 10)

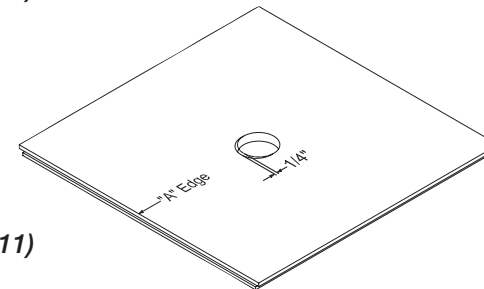

(Fig 11)

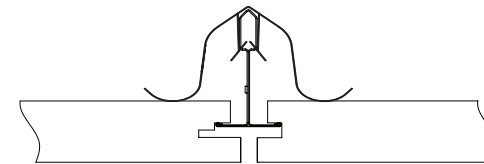

(Fig 12)

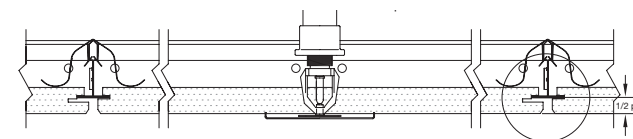

(Fig 13)

3.8 Potential Penetration Issues

3.8.1. Creating an Uneven Visual

Unlike in this example, Vector panels should maintain a 1/4" reveal between panels in all directions (*Fig 14*).

3.8.2. Shift Creating Misaligned Reveal

These are usually panels that receive sprinkler heads and high hat fixtures. The holes for penetrations must be large enough to allow the panel to be properly aligned (*Fig 15*).

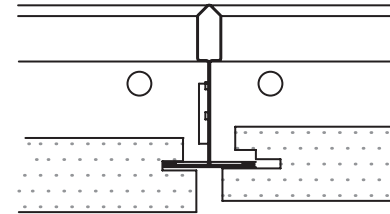

4. PANEL INSTALLATION & REMOVAL

4.1. General

Vector® ceiling panels are easily installed and removed from below the suspension system without the aid of tools or special equipment, allowing easy downward access to the plenum.

NOTE: The use of two installers is recommended for 24" x 96" panels. This will ease the installation of the long kerfed edges and proper fit into the suspension system.

4.2. Installing and Removing Full-size Panels

See page 15.

4.3. Orientation of Full-sized Panels

Install all full-size panels with the "A" edge facing in the same direction to provide access consistency. Border panels on non-directional panels may be quarter turned to avoid losing kerfed edges due to cuts. Align panels as you proceed to ensure a uniform reveal width in both directions. Pay attention to this alignment process. Minor variations in placement can be difficult to see from the scaffold, but will become obvious when looking down long runs of panels.

4.4. Odd-size Panels

Panels within the field of the install that are not full module size (ex. 20" x 24" panel next to linear light) can be ordered as made-to-order or must be field cut to replicate the factory edges. Example: Odd-sized panels next to a linear air diffuser.



(Fig 14)

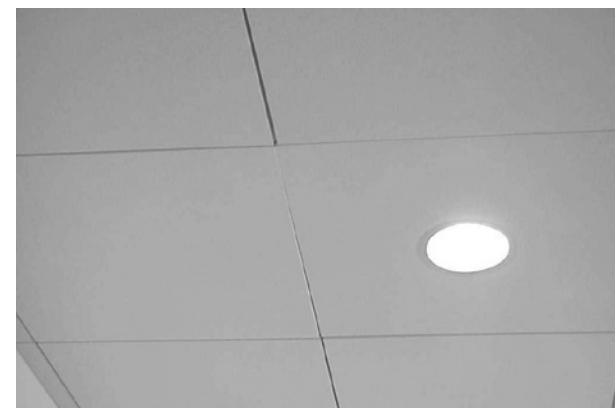
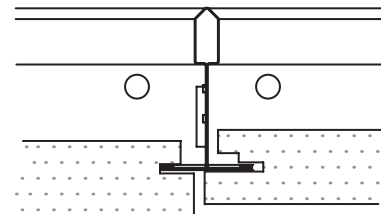

(Fig 15)

4.4.1. Measuring Odd-sized Panels

Measure, mark, and cut the panel 1/4" smaller than the dimension required. For example, if the panel is to fit into an 18" x 24" on center opening, it would be cut 17-3/4" wide (*Fig 16*).

4.4.2. Re-cut the Edge Detail

Turn the panel over and re-cut the reverse Tegular edge as dimensioned in the drawing below. Protect the face of the panel from damage (*Fig 17*).

4.4.3. Treating Field Cut Edges

All field cut edges "exposed to view" should be painted to match the factory finish. Armstrong® SuperCoat™ Ceiling Panel Touch-up Paint is recommended (items 5760 and 5761). Allow the paint to skin over before installing the panels.

Use a larger 1" wide brush to apply the touch-up paint to the cut edge. Apply a liberal amount of paint to the brush and coat several inches of the cut edge. For best results, use as few strokes as possible to cover the area. Avoid getting paint on the face of the panel and wipe off any excess as soon as possible. Paint will dry in approximately 30 minutes.

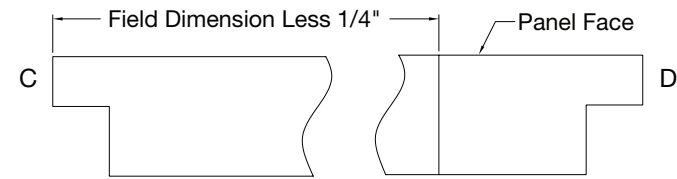

(Fig 16)

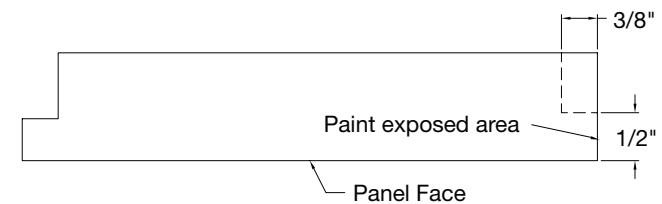

(Fig 17)

5. VECTOR® FIXTURE TRIM

Item No.	Length	Color*	Substrate	Pcs per Carton
VETK4ZW	4"	Blizzard White	Steel	24
VETK6ZW	6"	Blizzard White	Steel	24
VETK24ZW	24"	Blizzard White	Steel	24
VETK48ZW	48"	Blizzard White	Steel	24
VETK96ZW	96"	Blizzard White	Steel	24
Made-to-order	4"-96"	Blizzard White	Steel	24

*Additional colors available

5.1. General

The design of the Vector edge details creates a gap between the face of the suspension system and the kerf of the panel. This gap is necessary to allow the panel to lift sufficiently to allow installation and removal. This gap may be objectionable when type G light fixtures and air diffusers are used. For this reason, fixture trim kits are available for use with Vector panels.

5.2. Trim Installation

Vector Trim Kits are pre-mitered lengths of steel molding that snap onto the flanges of the grid with speed clips at the location of lay-in light fixtures or other accessories that sit in the suspension system (*Fig 18*). Vector Trim Kits include 24 straight pieces and the required speed clips.

- The trim kits should be installed before installing the ceiling panels.
- Speed clips should be placed with the flat side on the top of the grid flange to allow the panels to sit properly.
- Speed Clips should be placed near the ends of each piece, then no more than 2' on center thereafter (2 clips per 4", 6", and 24" piece, 3 clips per 48" piece, 5 clips per 96" piece).

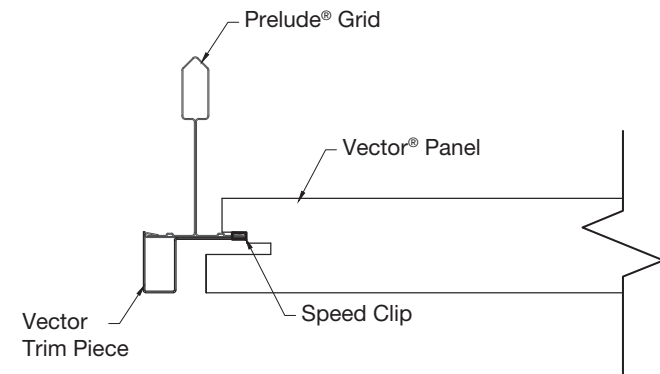

(Fig 18)

6. PERIMETER DETAILS

6.1. "A/B" General

There are two options for perimeter detailing:

- A) Panel face resting on molding
- B) Suspension flange resting on molding

Follow the instructions appropriate for the job conditions.

OPTION A

PANEL FACE RESTING ON MOLDING FLANGE

6.2.A Panel Face Resting on Molding

Molding items and accessories:

- 7808 – 2" "L" Wall Molding
- 7800 – 7/8" "L" Wall Molding
- 7875 – Shadow Molding
- 7897 – Seismic Shadow Molding for Vector®
- 7870 – Spring Border Clip
- BERC2 – Beam End Retaining Clip
- GCWA – Grip Clip Wall Attachment
- 2' and 4' Stabilizer Bars (Items 7425, 7445)

This installation method can be used for non-directional and directional panels. The suspension system is raised above the molding by 1/2". This clearance will allow the face of the panel to pass over and rest upon the support leg of the shadow molding, while the suspension system rests on the "step" of the shadow molding (item 7875 or seismic item 7897). An alternate option would be to use a standard "L" angle molding but hold the suspension system 1/2" above the horizontal flange (*Figs 19 & 20*).

6.2.1.A Corner Panel Installation

It is recommended to install corner panels first. Preparation of the corner panel will require the removal of two edges. Install the panel from above the suspension system and align the "B" edge with the suspension system flange. It may be necessary to swing a cross tee to the side to ease installation. Spring Border Clips (item 7870) must be used on two sides to maintain the location of the panel.

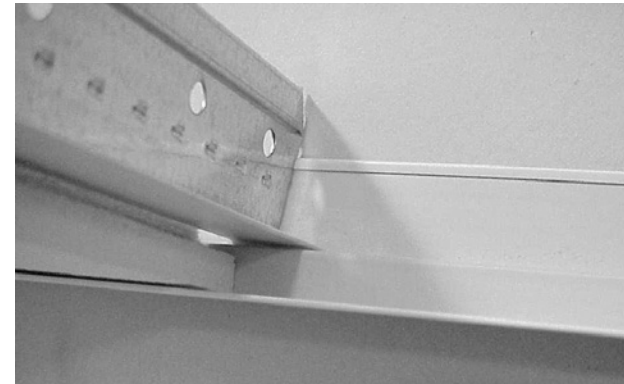
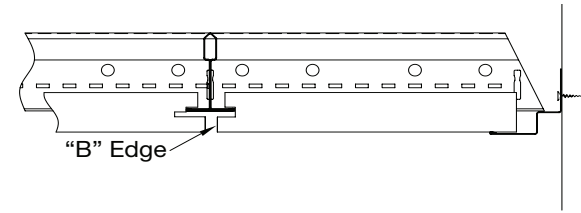

Correct shadow molding installation

This method will create a reveal where the suspension system passes over the molding flange, but it eliminates field cut panel edges that may be exposed to view.

(Fig 19)



Option A: Shadow Molding is the most user-friendly; items #7875 or #7897 (seismic) are recommended.

(Fig 20)

6.2.2.A Measuring Border Panels

Measure the distance from the edge of the suspension system flange to the step of the shadow molding (or wall, if you are using angle "L" molding) and add 1/8". Use this dimension to cut your border panel as outlined in the following section (Fig 21).

6.2.3.A Cutting Border Panels

Non-directional panels:

Mark and cut the panel to retain the "B" edge (removing the "A" edge). Non-directional panels can be quarter turned so that the "B" edge can be retained for all borders. Cut from the face side of the panel with a sharp knife and a straight edge.

Directional panels:

Installations with directional panels will require different methods on adjacent walls. Two opposite walls will be cut as detailed above (removing the "A" edge, wall 1). Because the panels are directional, the other two opposite walls will require a "C" or "D" edge to be removed, retaining portions of both the "A" and "B" edges of the panel (wall 2). Cut from the face side of the panel with a sharp knife and a straight edge (Fig 22).

6.2.4.A Installing Border Panels

Non-directional panels:

These panels install similarly to full size panels.

- 1) Start with the cut edge going up and over the flange of the molding and toward the wall
- 2) Raise the "B" edge of the panel up so that the panel is horizontal
- 3) Slide the "B" edge back onto the grid flange (Fig 23)

Use Mid-Point Clips on "C" or "D" edges (as detailed in section 2.3.1) if the border panel is equal to or greater than 30" wide.

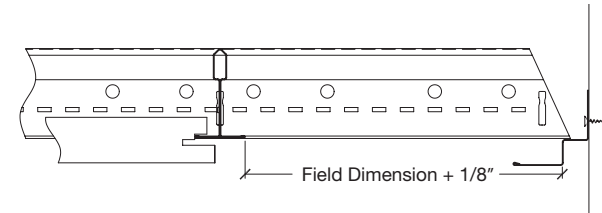

(Fig 21)

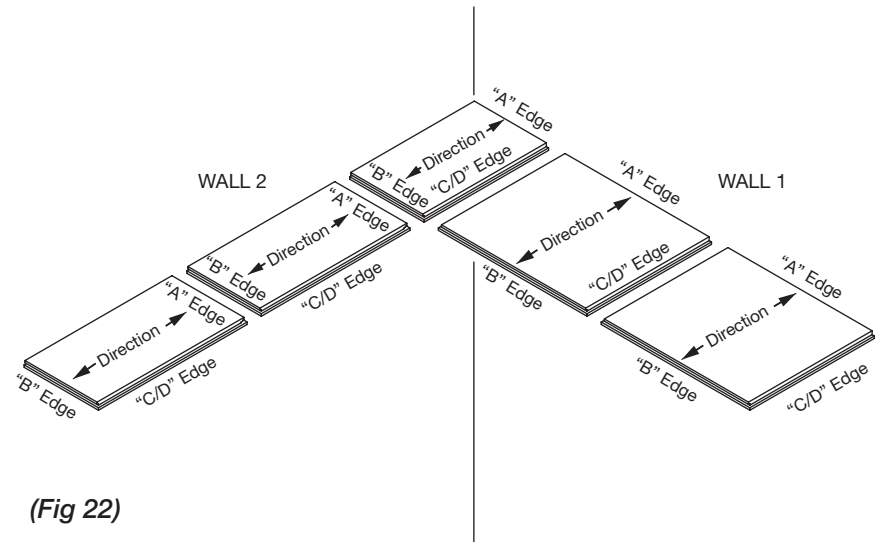

(Fig 22)

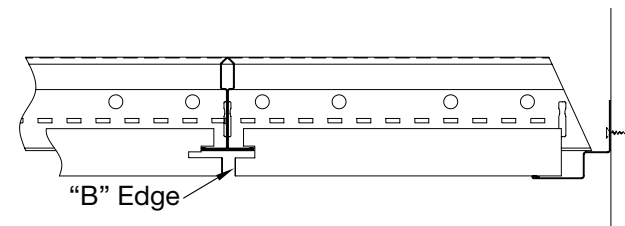

(Fig 23)

Directional panels:

Installations with directional panels will require different methods on adjacent walls. The two opposite walls with cut panels that retained the “B” edge will be installed following the steps above used for non-directional panels.

Cut border panels for the other two opposite walls (which retained portions of the “A” and “B” edge), require a different installation method. These panels require both the “A” and “B” edges to engage the grid flanges with the cut edge resting on the molding (*Fig 24*).

If Stabilizer Bars are being used at the perimeter:

- 1) Start with the cut edge going up and over the flange of the molding and toward the wall
- 2) Raise the ends of the grid so that the “A” and “B” edges can be engaged on the grid flanges

If GCWA or BERC2 clips are being used at the perimeter:

- 1) Start with the cut edge going up and over the flange of the molding and toward the wall
- 2) In order to have to the clearance needed to shift the panel to engage the “A” and “B” edges you may have to slide a cross tee to the side or roll the flange of the grid.

6.2.5.A Shimming Border Panels

All cut border panels installed with the panel face resting on molding require Spring Border Clips. Spring Border Clips serve two functions:

- 1) to maintain a consistent reveal
- 2) to prevent panels with only one engagement edge from shifting and disengaging from the grid flange. Insert Spring Border Clips between the edge of the panel and the molding (*Figs 25 & 26*).

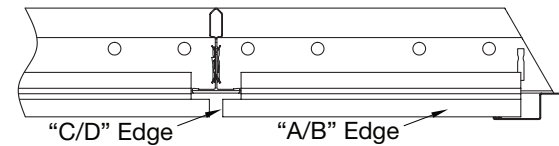

*Hold Down Clips not shown, but required

(Fig 24)

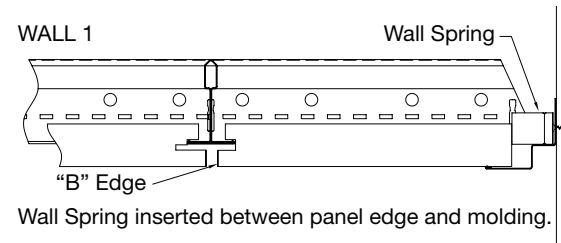

(Fig 25)

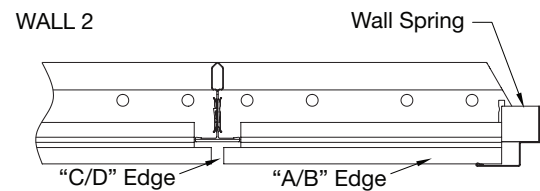



Wall Spring inserted between panel edge and molding.
NOTE: Hold Down Clips not shown, but required.

(Fig 26)

OPTION A

Panel Face Resting on Molding

24" x 24"
30" x 30"

-  **Vector® Hold Down Clip**
(item #442A)
-  **Mid-Point Clip**
(item #522 or 523)
-  **Spring Border Clip**
(item #7870)
- Stabilizer Bar – 2'**
(item #7425)
- Stabilizer Bar – 4'**
(item #7445)

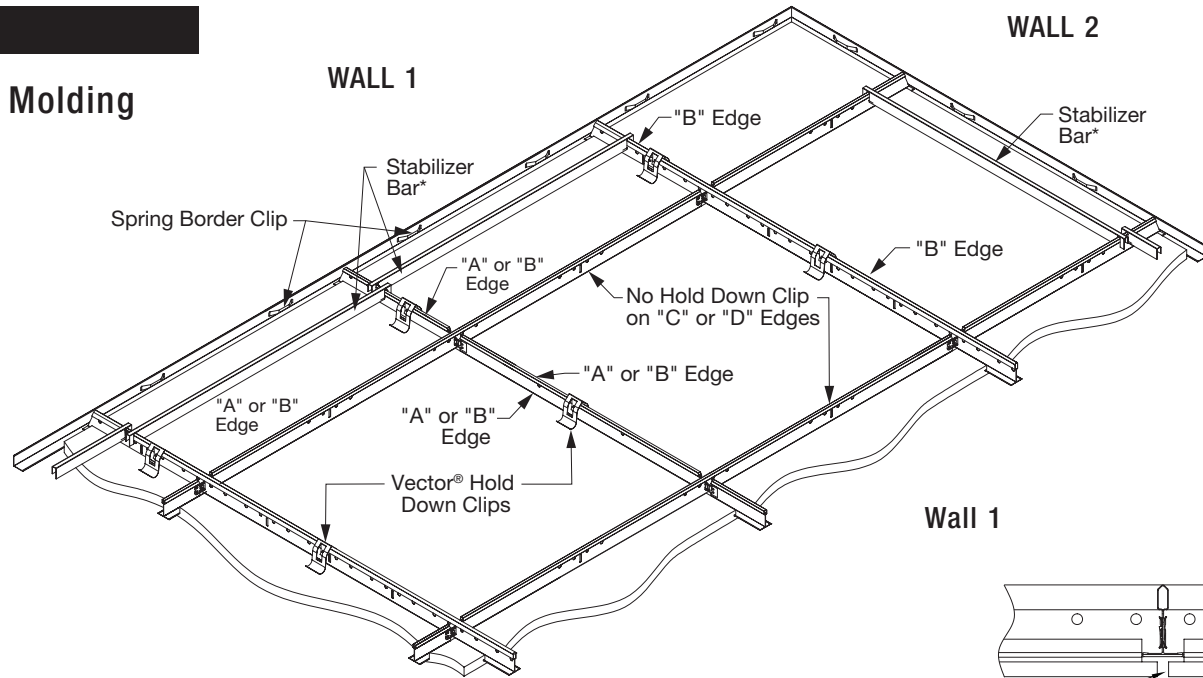

Wall 1

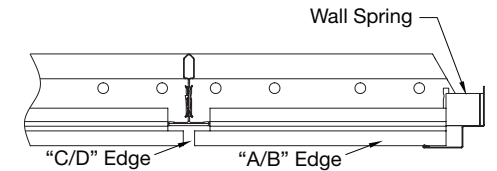

Wall Spring inserted between panel edge and molding.
NOTE: Hold Down Clips not shown, but required.

Wall 2

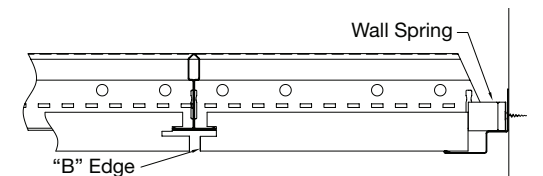

Wall Spring inserted between panel edge and molding.

Panels with C/D edges over 30" in length 48" x 48", Made-to-order sizes

* Stabilizer Bars may be replaced by BERC, BERC2, or GCWA to stabilize cross tees at the perimeter.

In Seismic Design Categories D, E, and F, BERC2 is required if any molding other than 2" "L" angle (item #7808) molding is used.

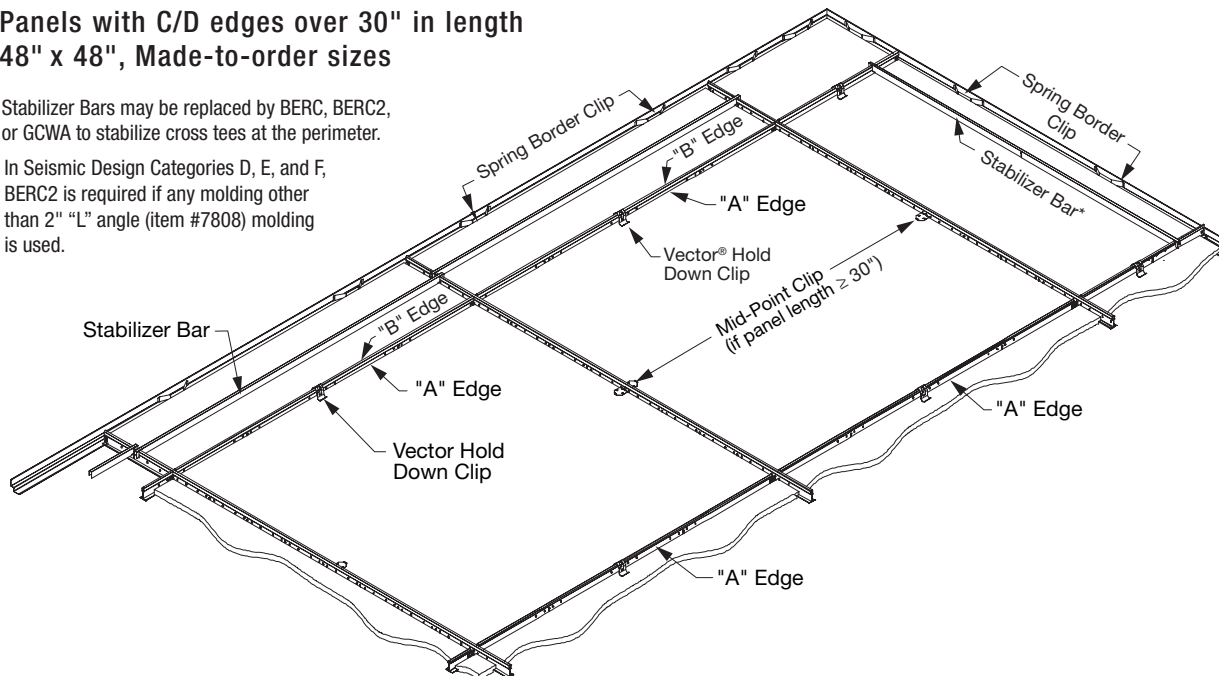

OPTION B

GRID RESTING ON MOLDING FLANGE

6.2.B Suspension System Resting on Molding

- Item 440 – Ultima® Border Clip
- Item 441 – Optima® and Lyra® Border Clip
- Item 443 – Calla® Border Clip

Wall Molding Options:

- Item 7808 – 2" "L" Wall Molding
- Item 7800 – 7/8" "L" Wall Molding

Grid Spacing at Perimeter Options:

- Item BERC2 – Beam End Retaining Clips
- Item GCWA – Grip Clip Wall Attachment
- Items 7425, 7445 – 2' and 4' Stabilizer Bars

When the suspension system rests directly on the molding flange, the border panels are field cut against the molding.

6.2.1.B "C/D" Edge along the Perimeter

When this option is used, the cut is made parallel to either the "C" or "D" edge of the panel (*Fig 27*). This will retain the "A" and "B" details on opposite sides of the border panel. Non-directional, non-plank panels may be rotated as you move around the walls to retain the kerfed edges on two opposite sides of each panel; directional and plank panels cannot.

6.2.2.B. Measuring Border Panels

Measure the size of the opening from the edge of the suspension to the edge of the molding and add 7/16". Measure and mark the face side of the panel at both edges (*Fig 28*).

6.3.B Border Panel Orientation – Directional and Plank

Directional and plank panels cannot be quarter turned at the perimeters. Different procedures are required along perimeters that run parallel with the "A" and "B" edges.

6.4.B "A" Kerf along the Perimeter

When this option is used, the cut is made parallel to the kerfed edge of the panel. For ease of installation and panel accessibility, retain the "A" kerf and cut off the "B" kerf if possible. Support the cut side of the panel by inserting Vector® Border Clips. Clips must be within 6" of the end and spaced 12" along the cut edge (*Fig 29*).

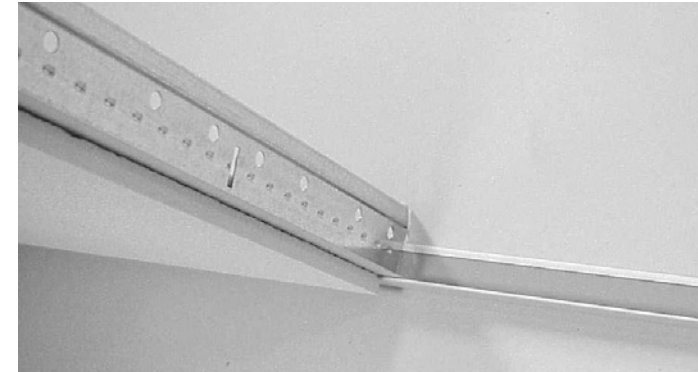
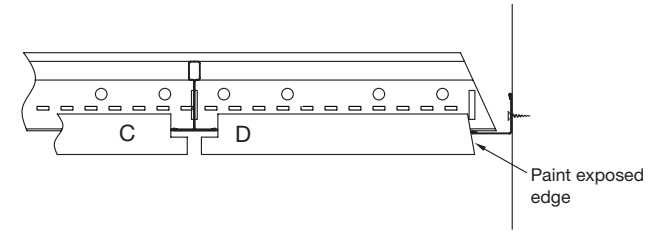

(Fig 27)

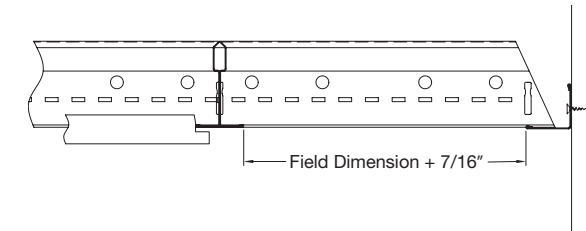

(Fig 28)

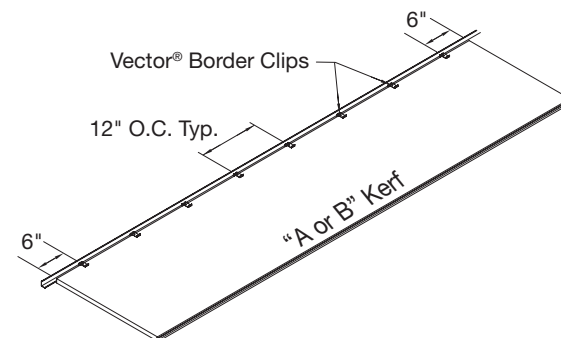

(Fig 29)

To install this panel, fully engage the “A” kerf on the suspension system. Raise the cut edge up until the border clips are above the wall molding. Slide the panel towards the wall until the access kerf of “A” edge drops down into the correct position. The Vector Border Clips will support the cut edge along the wall molding (*Fig 30*).

6.5.B. “B” Kerf along the Perimeter

This option may be used when required but makes the panel non-accessible. The cut is made parallel to the “B” kerf. To install this panel, engage the “B” kerf on the suspension system and raise the cut edge up until it is above the wall molding. From above the suspension system, insert a Vector Border Clip along the cut edge. Clips must be within 6” of the end and spaced 12” along the cut edge (*Fig 31*).

6.6.B Cutting and Installing the Panel

Cut from the face side using a sharp knife and a straight edge. Install the same as a full-size panel.

6.6.1.B. Curved and Angled Walls

Panels that meet curved or angled walls can be marked using the same method that is used for standard Tegular edge panels. Cut the panel large enough to rest on the suspension system and wall molding as shown.

Slide the panel away from the wall until it touches the web of the suspension system. Scribe and cut the panel to the edge of the flexible wall molding. Use Vector® Border Clips to support the edge if needed (*Fig 32*).

6.6.2.B Corner Panel Installation

Preparation of the corner panel will require the removal of two edges. Mark and cut the panel to retain a portion of the “A” edge. Support the opposite side of the panel by inserting Vector Border Clips. Install clips 6” from the edge and then every 12” O.C. Follow Section 6.5.B., if the “B” kerf is retained.

6.6.3.B Ceiling Height Partitions Walls (*Fig 33*)

For ceiling height partitions, field scribe the panel against the wall.

7. SEISMIC CONSIDERATIONS

7.1 Border Clips (Screw Attachment)

The following modification to the Vector Border Clip is required for Optima® and Lyra® Vector large panel sizes including 48” x 48”, 24” x 72”, 24” x 96”, and made-to-order panels greater than 48” in length installed in Seismic Design Categories C, D, E, and F (*Fig 34*).

Insert the Vector Border Clip on the panel. Push an 8 x 9/16 sheet metal screw (or equivalent) through the clip into the plank to secure the border clip to the panel.

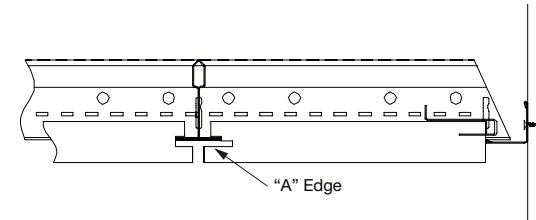

(Fig 30)

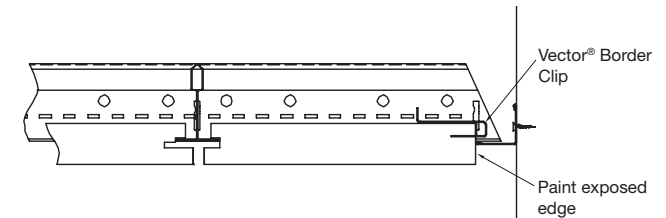

(Fig 31)

**Hold down clips not shown, but required*

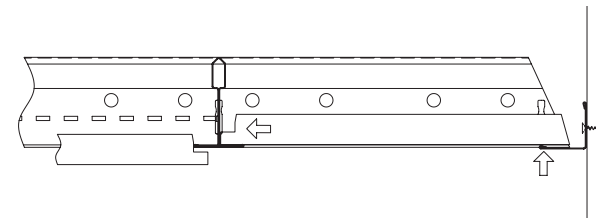

(Fig 32)

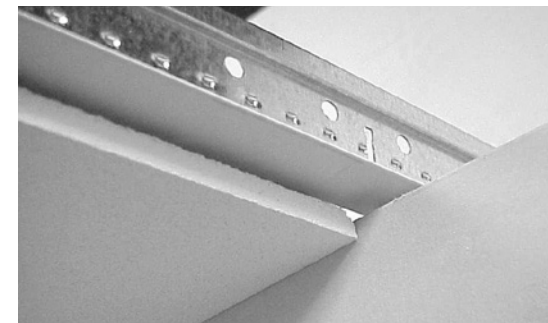



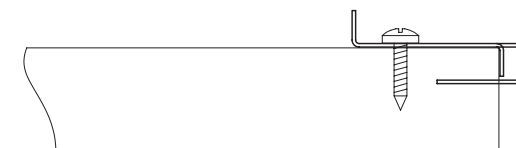

(Fig 33)



(Fig 34)

OPTION B

Suspension System Resting on Molding 24" x 24"

-  **Ultima® Border Clip** (item #440)
-  **Optima® and Lyra® Vector® Border Clip** (item #441)
-  **Calla® Vector Border Clip** (item #443)
-  **Vector Hold Down Clip** (item #442A)
-  **Mid-Point Clip** (item #522 or 523)
- Stabilizer Bar – 2'** (item #7425)
- Stabilizer Bar – 4'** (item #7445)

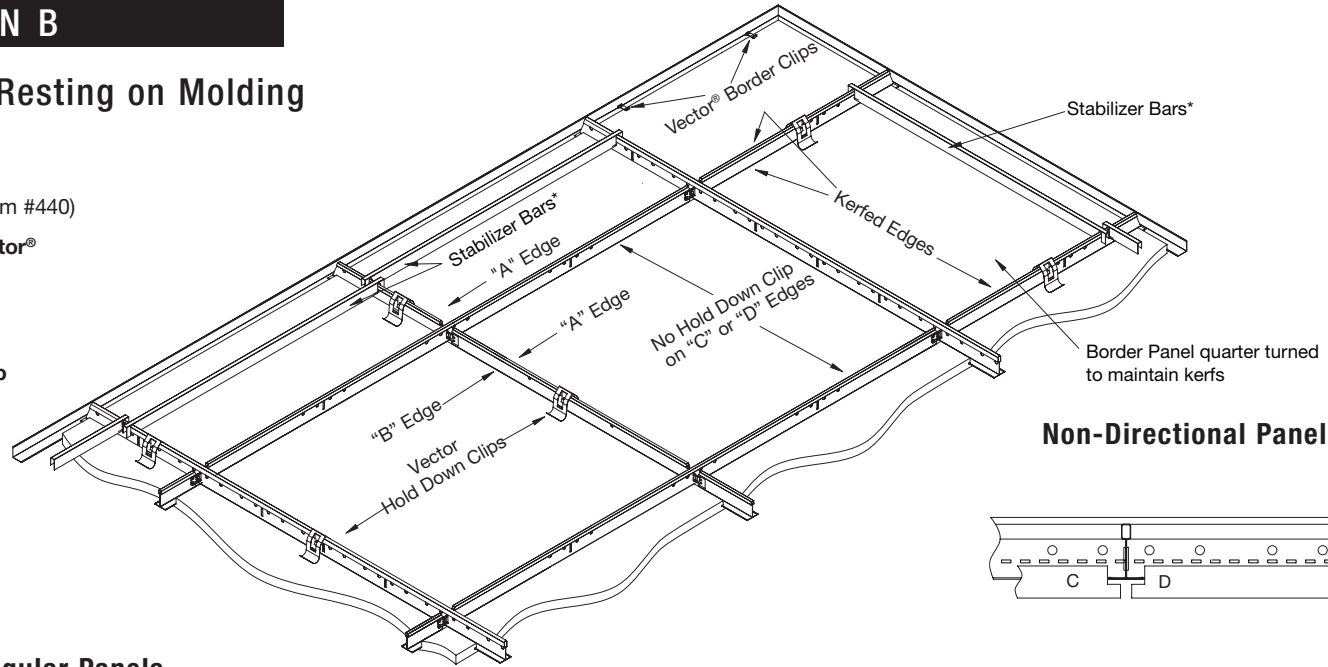

Directional and Rectangular Panels

Wall 1

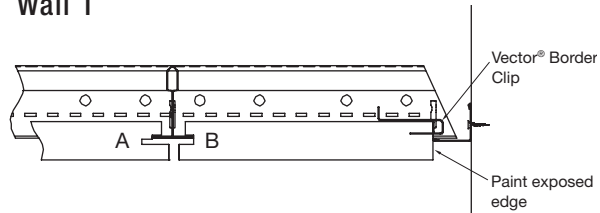

Wall 2

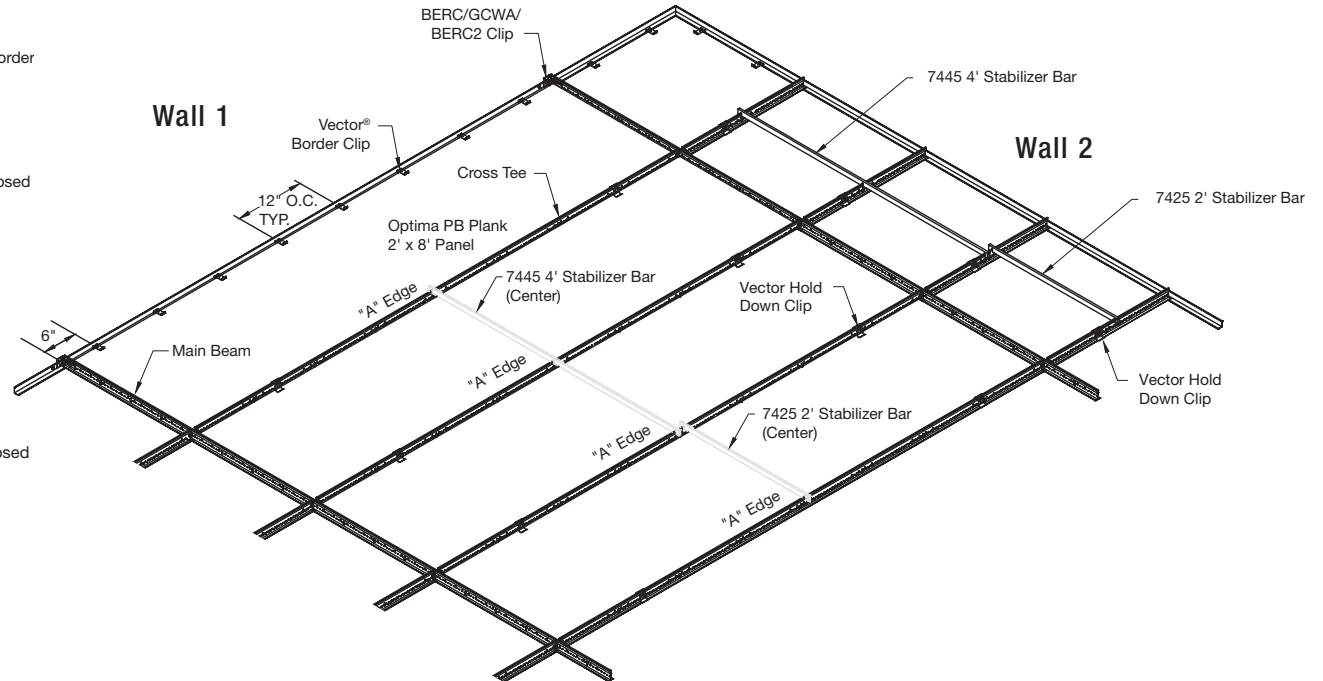
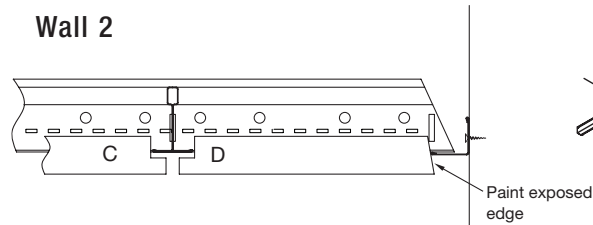

* Stabilizer Bars may be replaced by BERC, BERC2, or GCWA to stabilize cross tees at the perimeter.

In Seismic Design Categories D, E, and F, BERC2 is required if any molding other than 2" "L" angle (item #7808) molding is used.

HOW TO INSTALL Vector® Panels

1. Place the deepest portion of the “A” kerfed edge onto the suspension system flange.

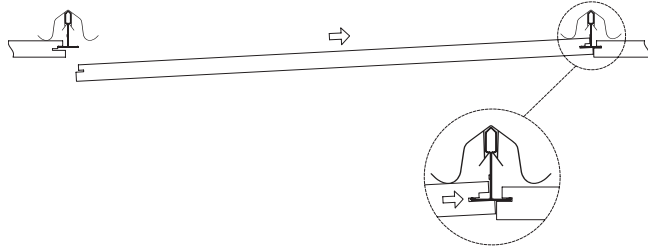

2. Raise the opposite “B” kerfed edge up into the suspension system opening.

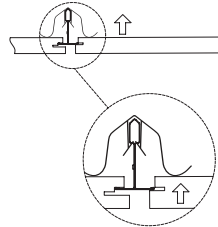

3. Slide the panel back onto the suspension system flange. Make sure that the “A” edge drops into position as shown.

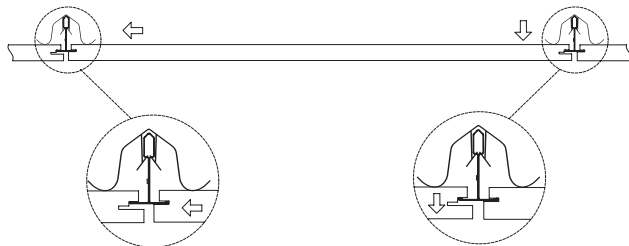

4. **Required for panels equal to or greater than 30" in length.** Gently push up on the “C” and “D” edges at the location of the Mid-Point Clip to engage the clip on the suspension system flange.

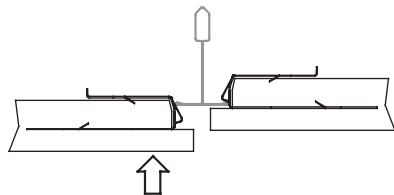

HOW TO REMOVE Vector Panels

1. Push the panel up against the suspension system flanges and find the one direction it will move.

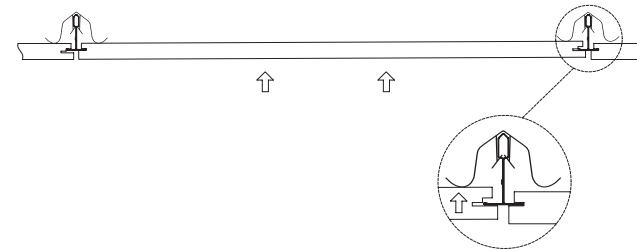

2. Slide the panel until it contacts the adjacent panel.

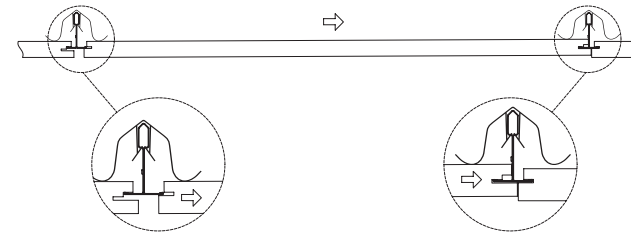

3. Lower the opposite edge out of the suspension system opening. Slide the panel off of the flange. Do not allow the panel to hinge or hang on the suspension system flange, as this may cause damage to the kerf, resulting in poor alignment when the panel is reinstalled.

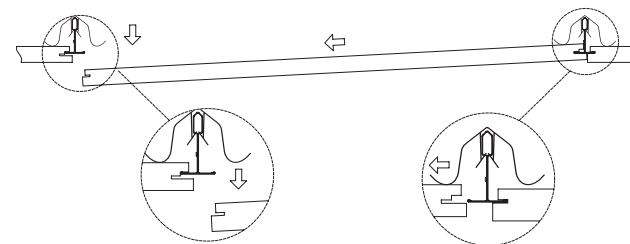

CEILING PANEL ITEMS		
Product	Item #	Directional
OPTIMA	3900, 3901, 3902, 3903, 3904, 3905, 3906, 3907, 3908, 3908, 3909	Non-directional
ULTIMA	1907, 1908, 1920, 1921	Non-directional
ULTIMA Create!	Z1920UC1	Directional
OPTIMA Create!	Z3901OC1	Directional
LYRA	8494, 8495, 8496, 8497, 9498, 8499	Directional
CALLA	2814, 2815	Directional
Other sizes available – see data pages for more information		
CEILING PANEL ACCESSORIES		
Item #	Item Name	
440	Ultima Border Clip for Vector® Panel	
441	Optima and Lyra Border Clip for Vector Panel	
442A	Hold Down Clip for Vector Panels	
443	Calla Border Clip for Vector Panels	
7425	24" Stabilizer Bar	
7431	30" Stabilizer Bar	
7445	48" Stabilizer Bar	
7870	Spring Border Clip	
522	Mid-Point Clip (Optima Vector, Ultima Vector)	
523	Mid-Point Clip (Calla Vector)	
VETK	Vector Trim Kits	

MORE INFORMATION

For more information, or for an Armstrong Ceilings representative, call 1 877 276 7876.

For complete technical information, detail drawings, CAD design assistance, installation information, and many other technical services, call TechLine customer support at 1 877 276 7876 or FAX 1 800 572 TECH.

All trademarks used herein are the property of AWI Licensing LLC and/or its affiliates.

© 2021 AWI Licensing Company Printed in the United States of America

