

Wall Application

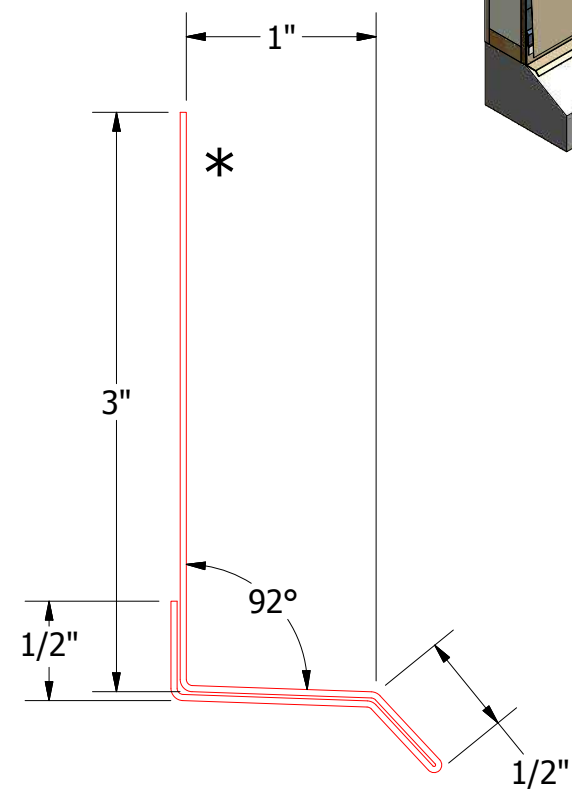

HCAXXX-Base Trim

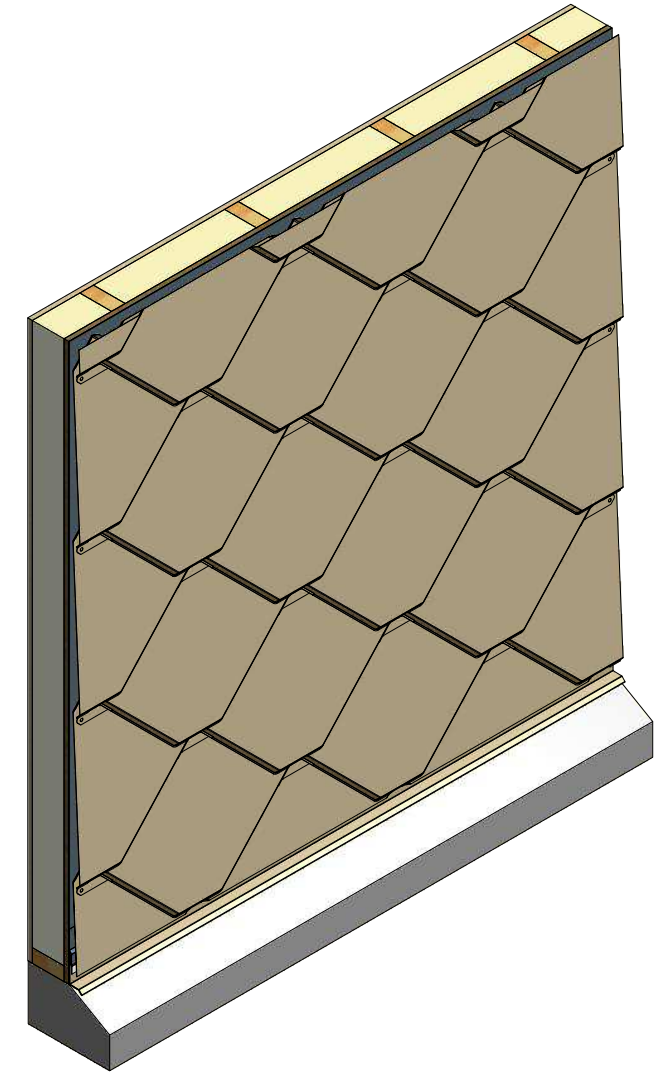
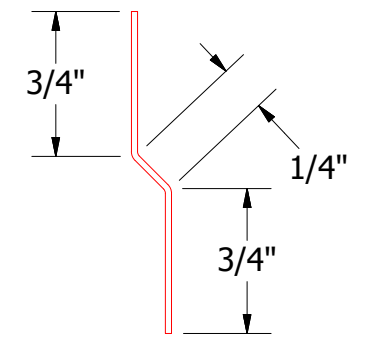

HCA975-Joggle Cleat



ATAS INTERNATIONAL, INC
 Allentown PA
 610-395-8445
 Mesa AZ
 480-558-7210

REV. NO.	DATE	DESCRIPTION OF REVISION	BY	APP

TITLE			Castle Top Base Detail		
DWG. NO.	DR	DATE	APP	DATE	
	KRK	9/2/2014			
MATERIAL			SH. SIZE	SCALE	
			B	X:X	

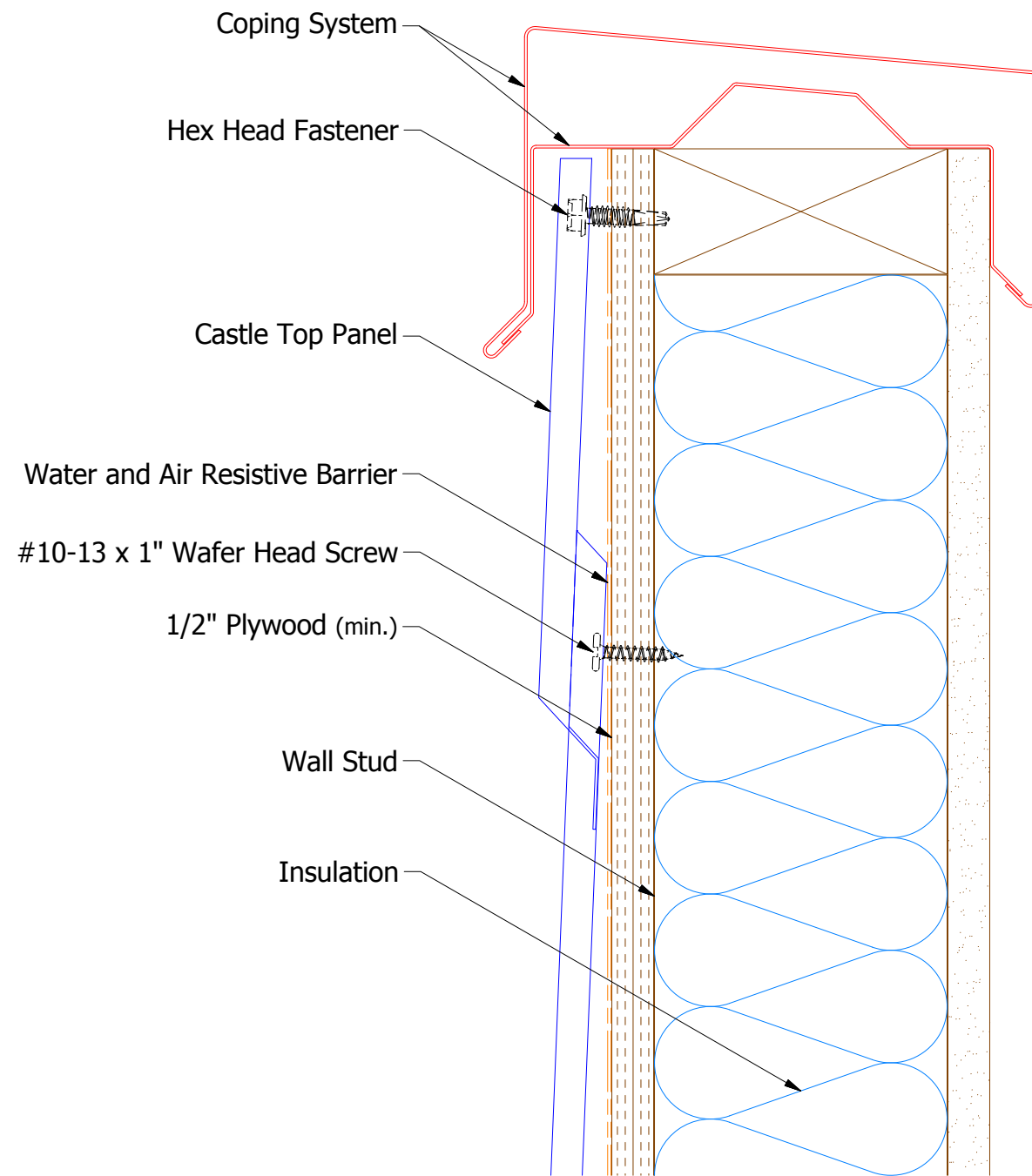

Wall Application

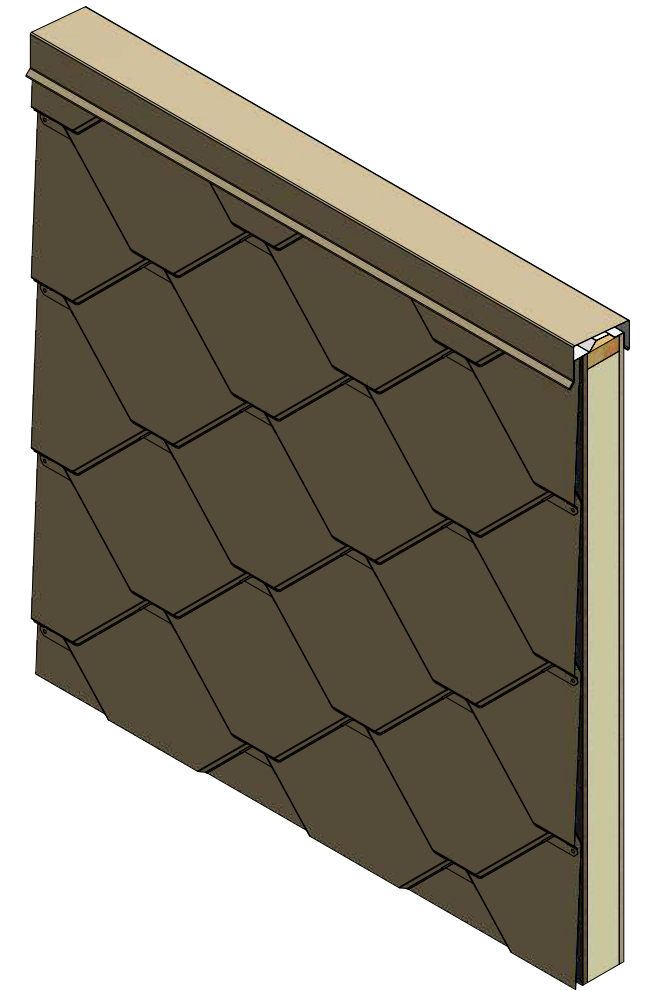

ATAS INTERNATIONAL, INC
 Allentown PA
 610-395-8445
 Mesa AZ
 480-558-7210

TITLE		Castle Top Coping Detail	
DWG. NO.	DR	DATE	8/29/2014
	KRK	APP	DATE
MATERIAL	SH. SIZE	B	SCALE
			X:X

REV. NO.	DATE	DESCRIPTION OF REVISION	BY	APP

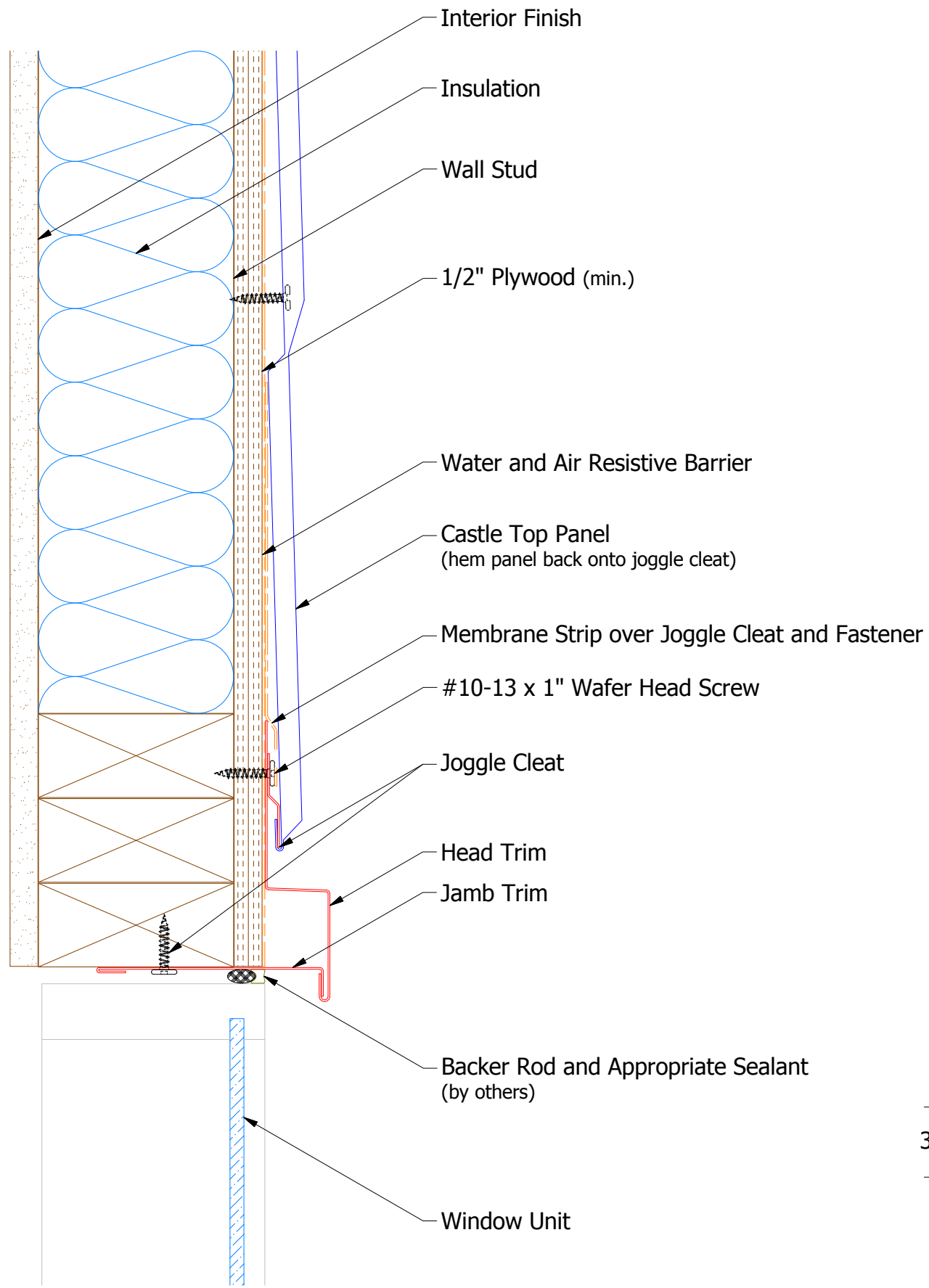

Wall Application

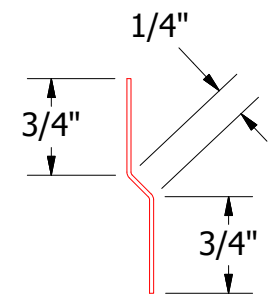

HCA975-Joggle Cleat

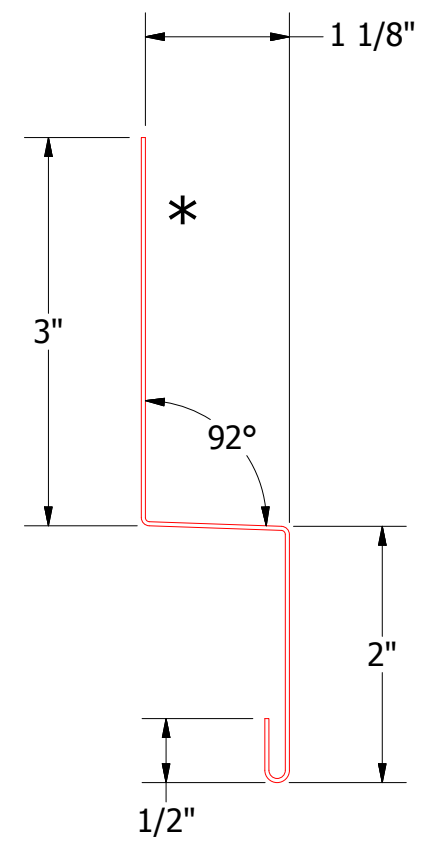

HCAXXX-Head Trim

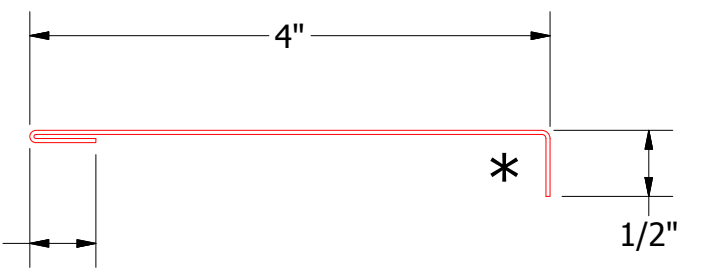
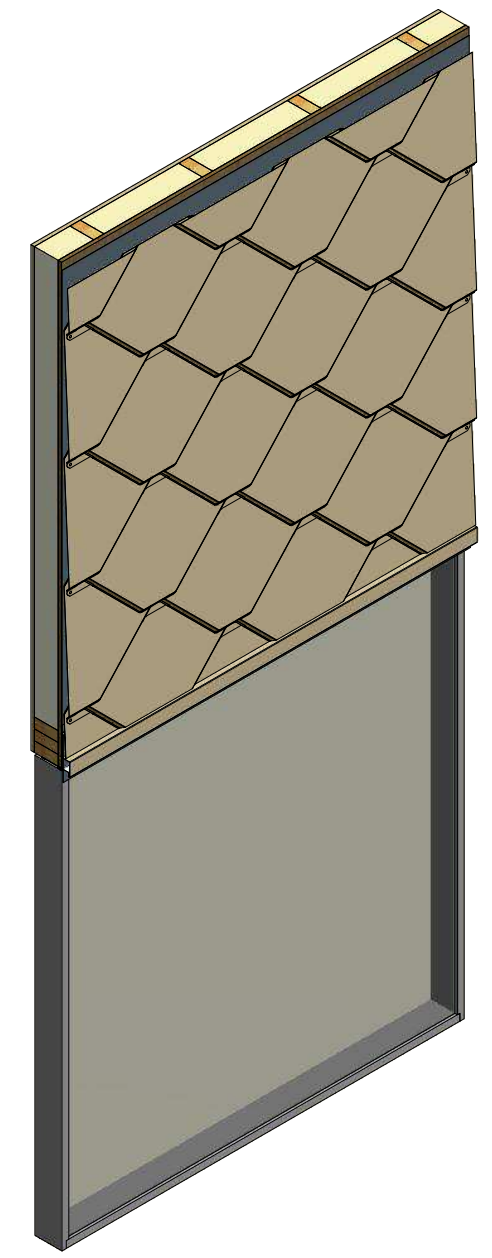

HCA671-Jamb Trim

 ATAS INTERNATIONAL, INC Allentown PA 610-395-8445 Mesa AZ 480-558-7210		TITLE	
		Castle Top Head Detail	
DWG. NO.	DR	DATE	
	KRK	8/29/2014	
MATERIAL	APP	DATE	
REV. NO.	DATE	DESCRIPTION OF REVISION	BY APP
	SH. SIZE	B	SCALE X:X

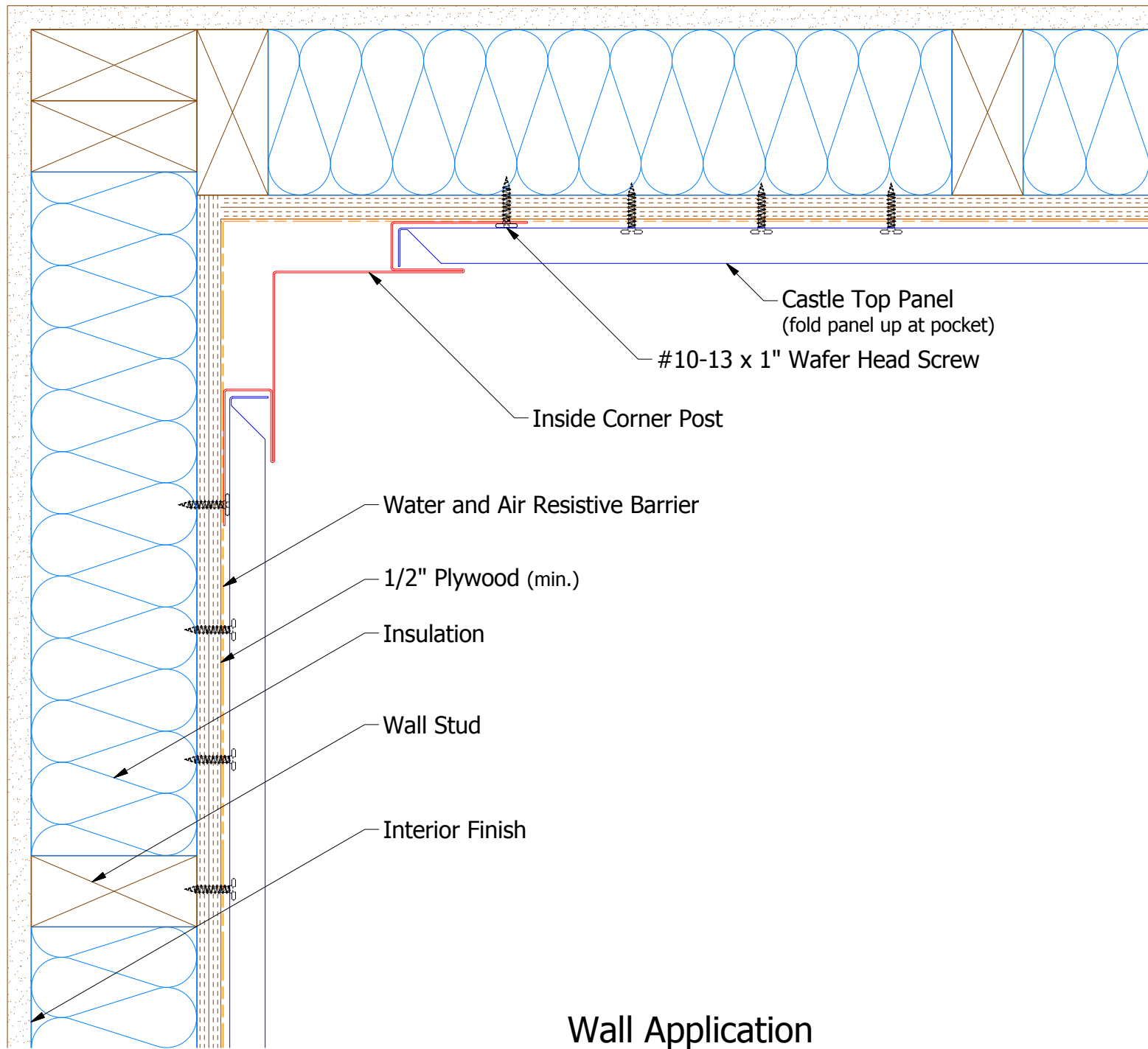

Wall Application

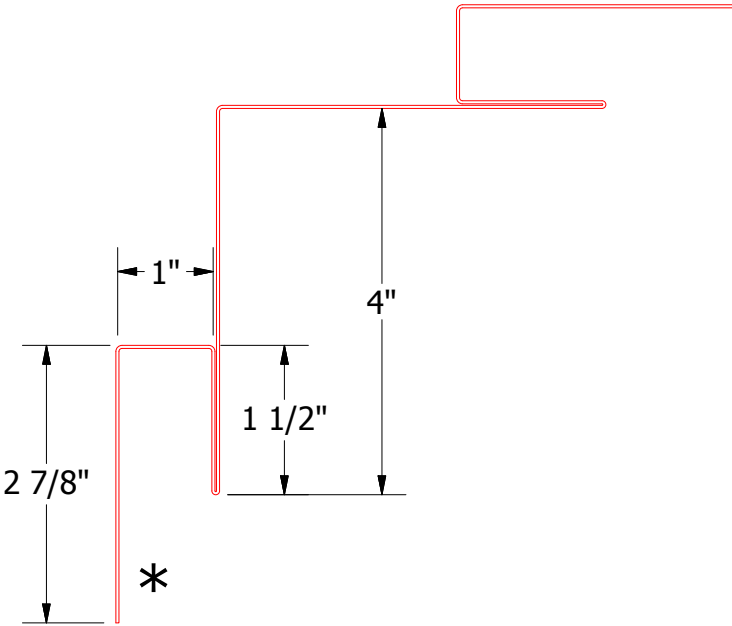
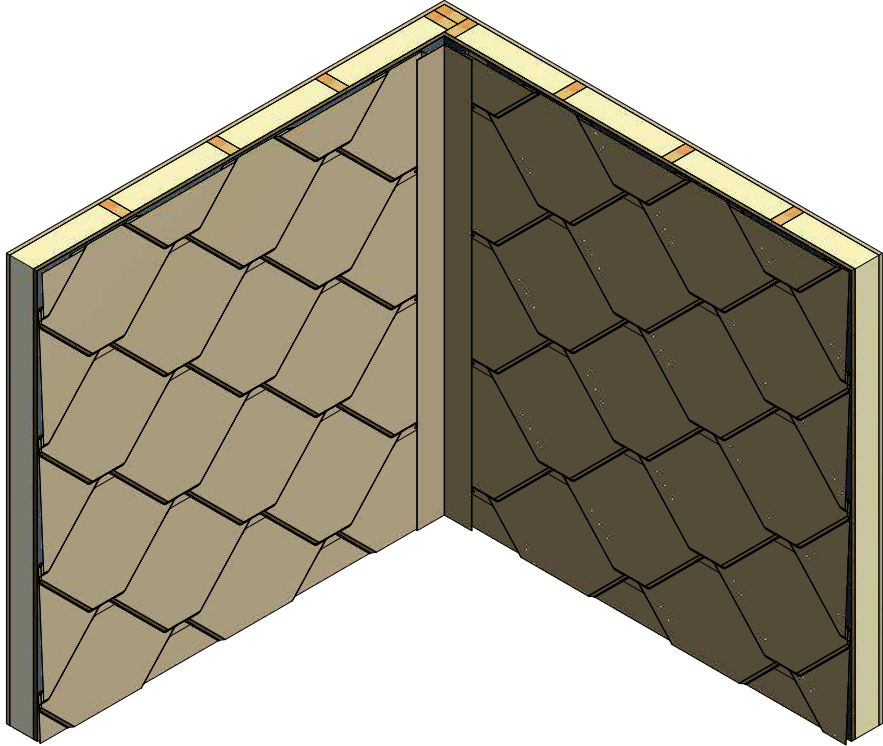

HCAXXX-Inside Corner Post



ATAS INTERNATIONAL, INC
 Allentown PA
 610-395-8445
 Mesa AZ
 480-558-7210

TITLE		Castle Top Inside Corner Detail	
DWG. NO.	DR	DATE	8/29/2014
	KRK	APP	DATE
MATERIAL	SH. SIZE	SCALE	X:X
	B		

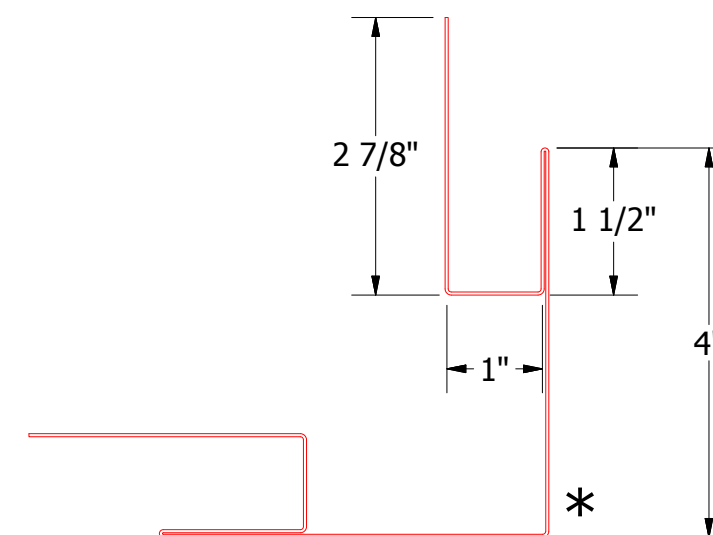
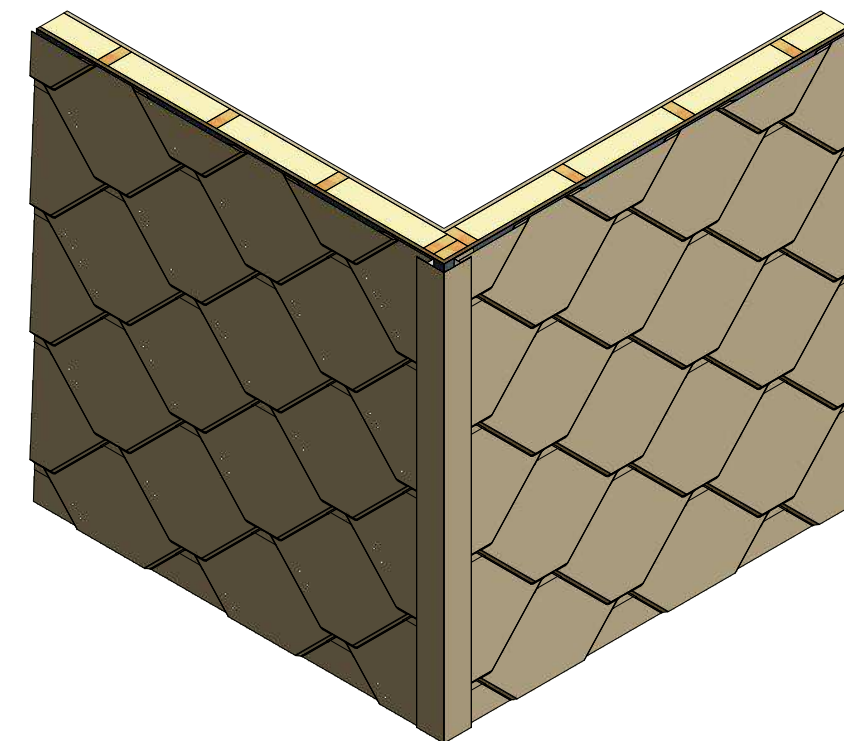
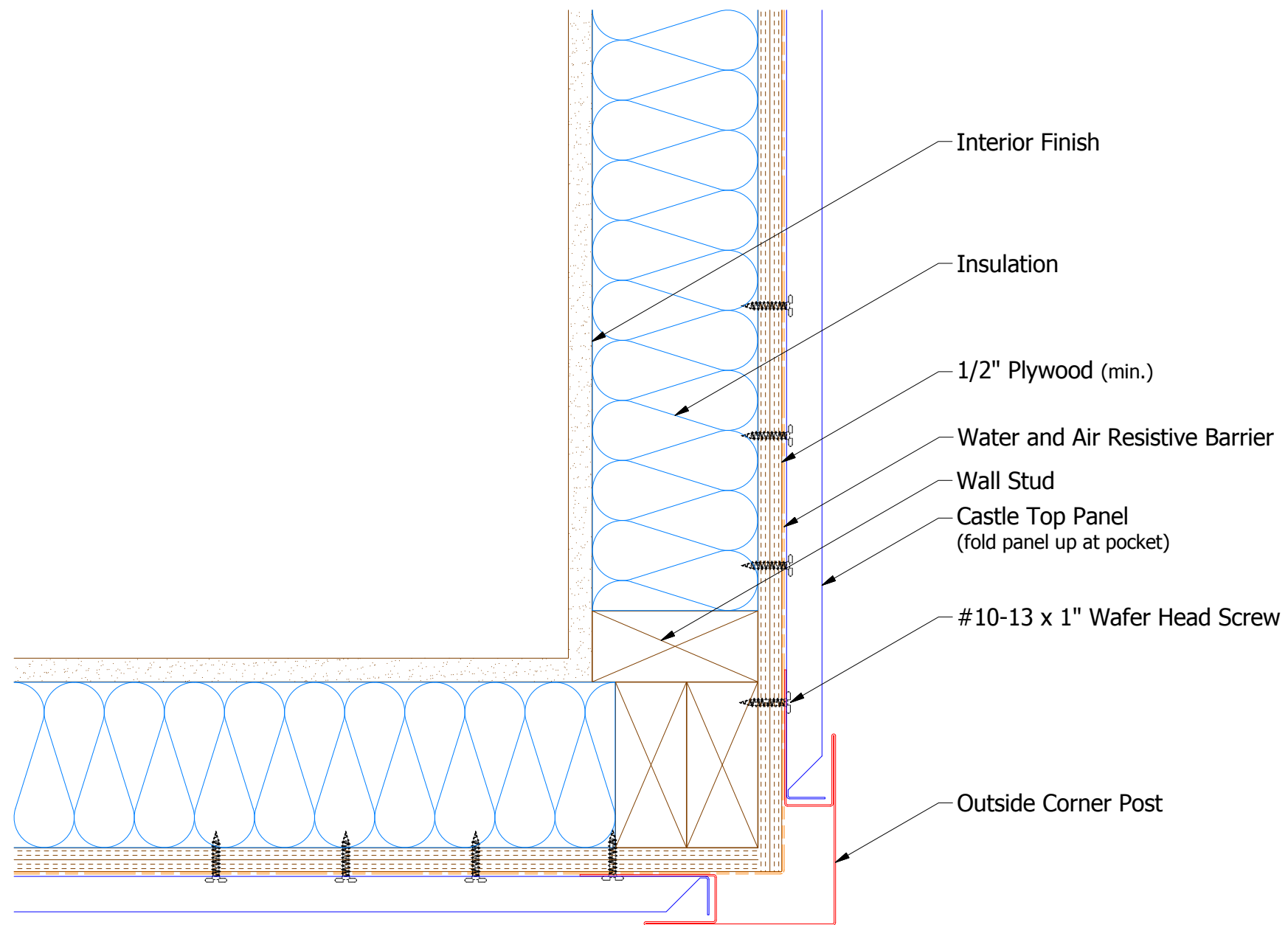
REV. NO.	DATE	DESCRIPTION OF REVISION	BY	APP

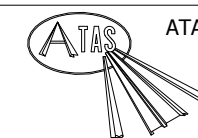

HCAXXX-Outside Corner Post



ATAS INTERNATIONAL, INC
 Allentown PA
 610-395-8445
 Mesa AZ
 480-558-7210

TITLE **Castle Top Outside Corner Detail**

REV. NO.	DATE	DESCRIPTION OF REVISION	BY	APP	DWG. NO.	DR	DATE
						KRK	9/2/2014
					MATERIAL	APP	DATE
						SH. SIZE	SCALE
						B	X:X

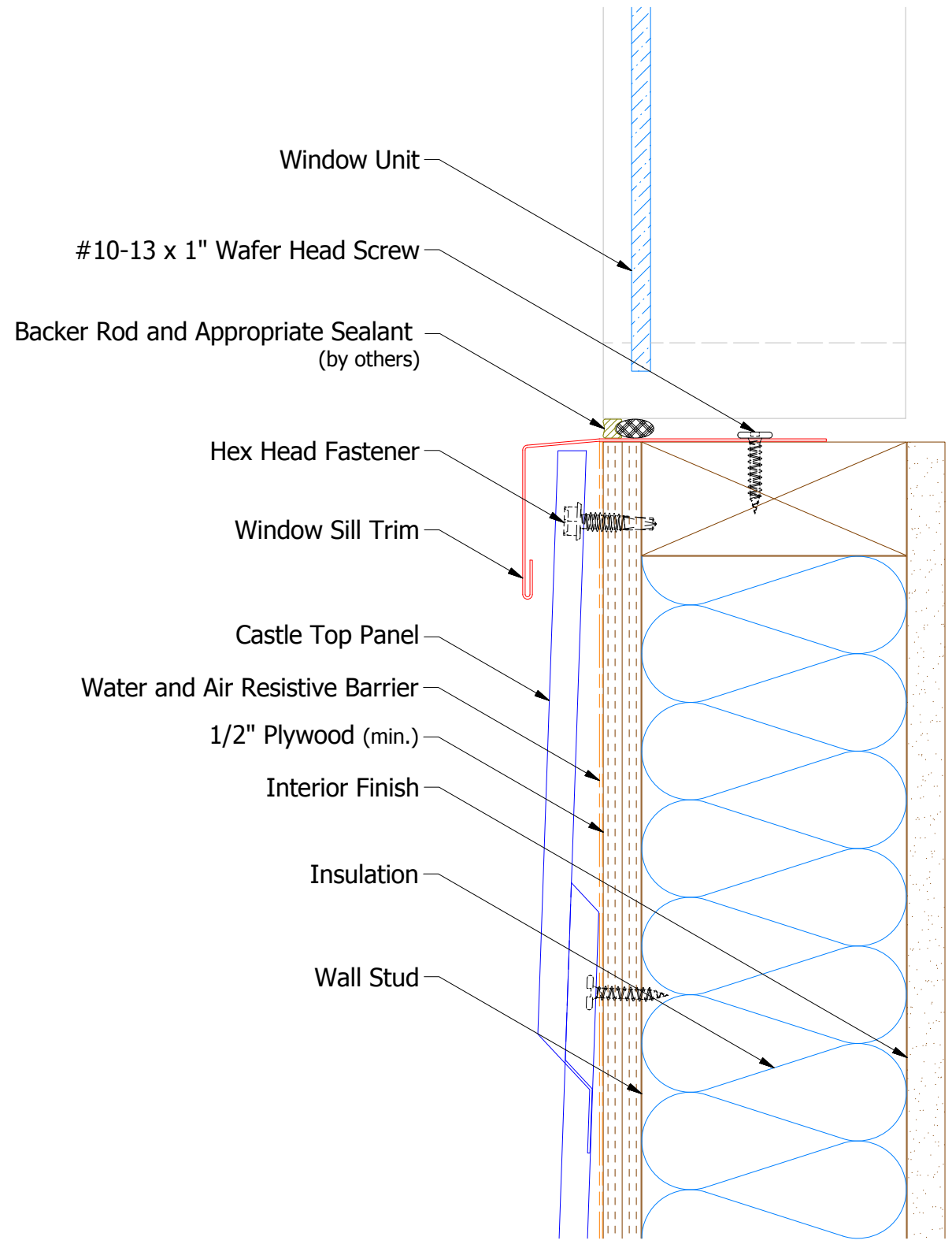

Wall Application

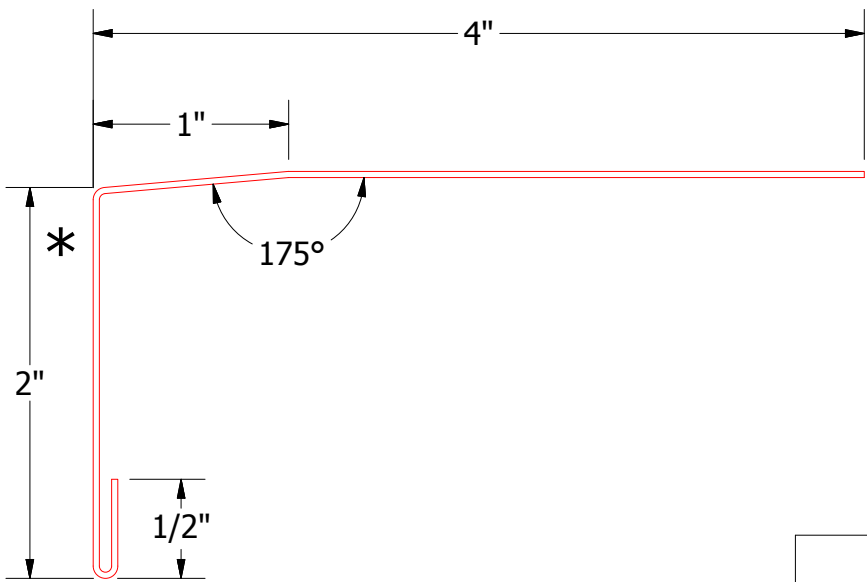
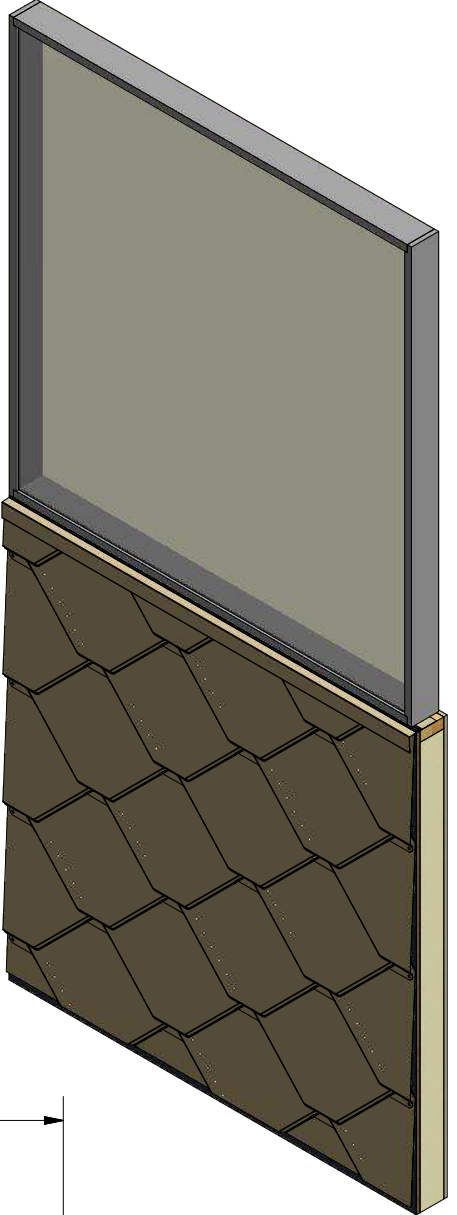

HCA~~XXX~~-Window Sill Trim

ATAS ATAS INTERNATIONAL, INC
 Allentown PA
 610-395-8445
 Mesa AZ
 480-558-7210

TITLE				Castle Top Window Sill Detail	
DWG. NO.		DR		DATE	
		KRK		9/2/2014	
MATERIAL		APP		DATE	
		SH. SIZE		SCALE	
		B		X:X	
REV. NO.	DATE	DESCRIPTION OF REVISION	BY	APP	

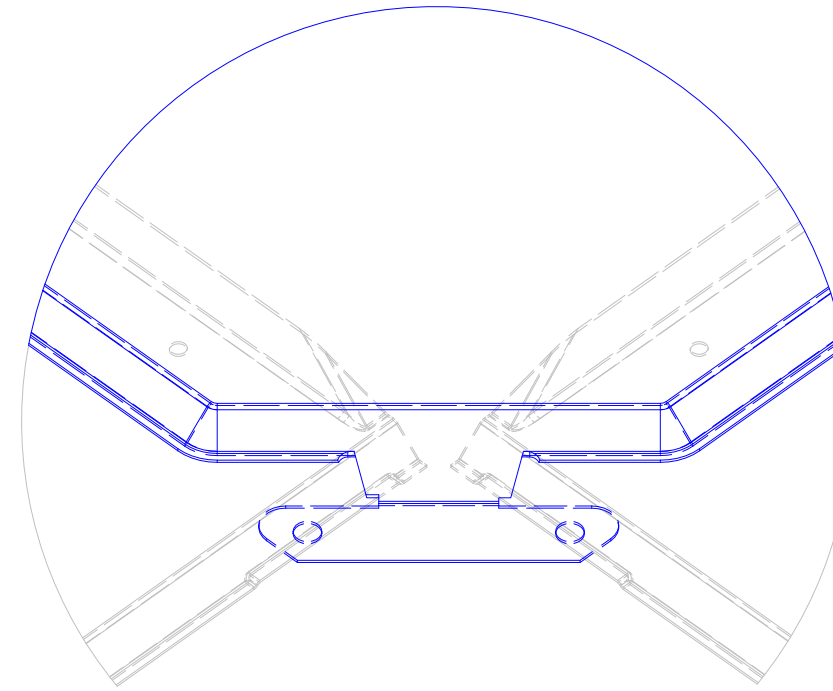
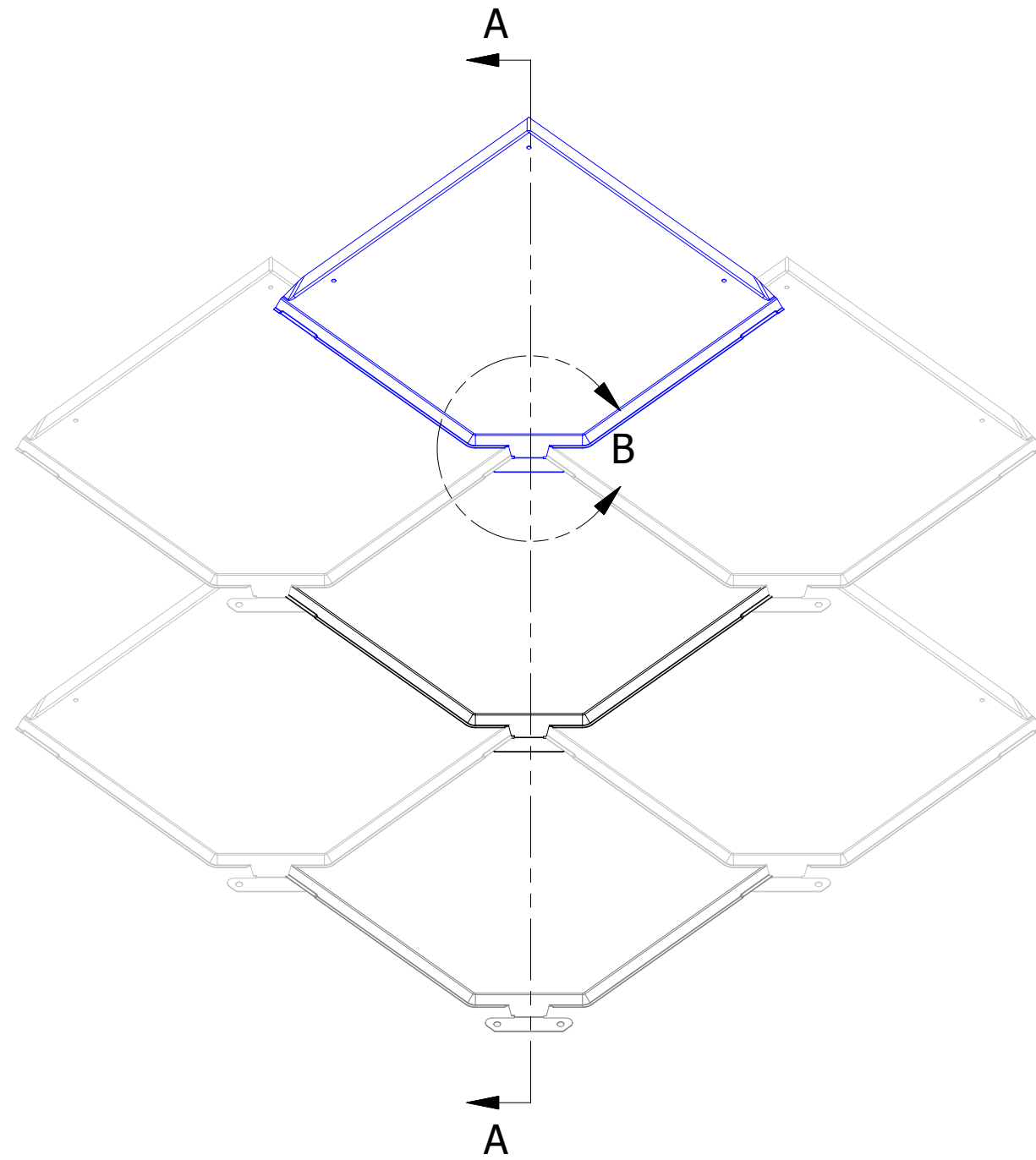

DETAIL B

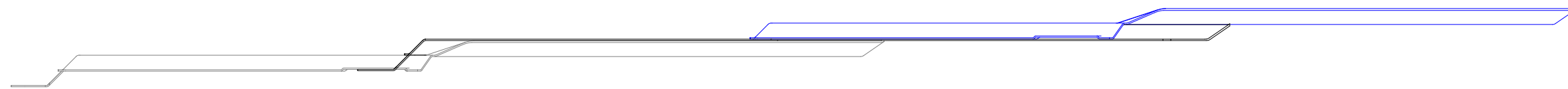

SECTION A-A



ATAS INTERNATIONAL, INC
 Allentown PA
 610-395-8445
 Mesa AZ
 480-558-7210

TITLE
CastleTop Panel Assembly Detail

REV. NO.	DATE	DESCRIPTION OF REVISION	BY	APP	DWG. NO.	DR	KRK	DATE	7/2/2014
						APP		DATE	
					MATERIAL	SH. SIZE	B	SCALE	X:X

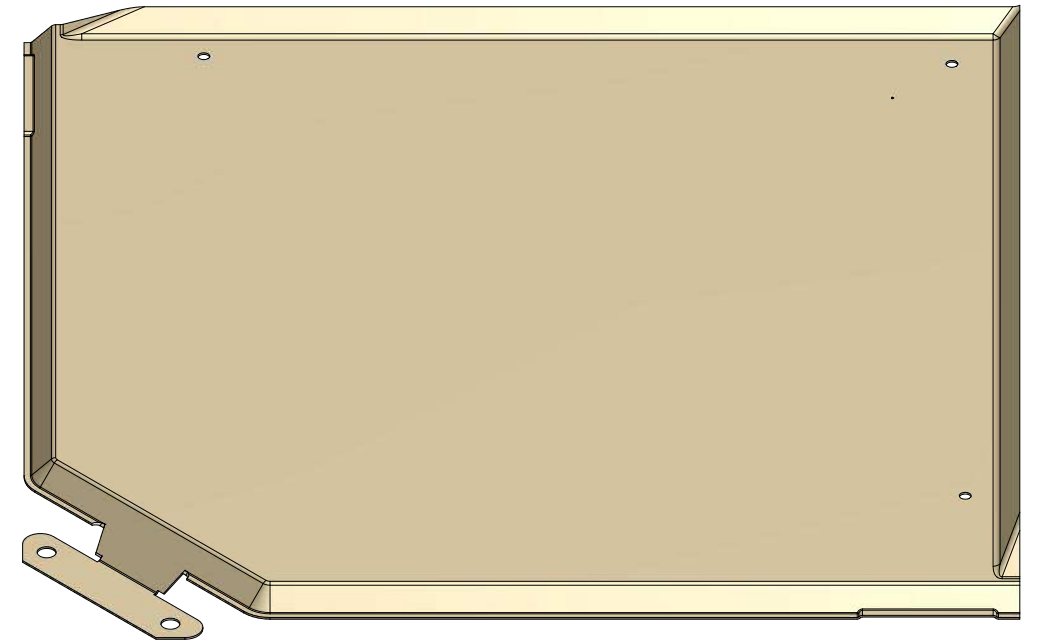
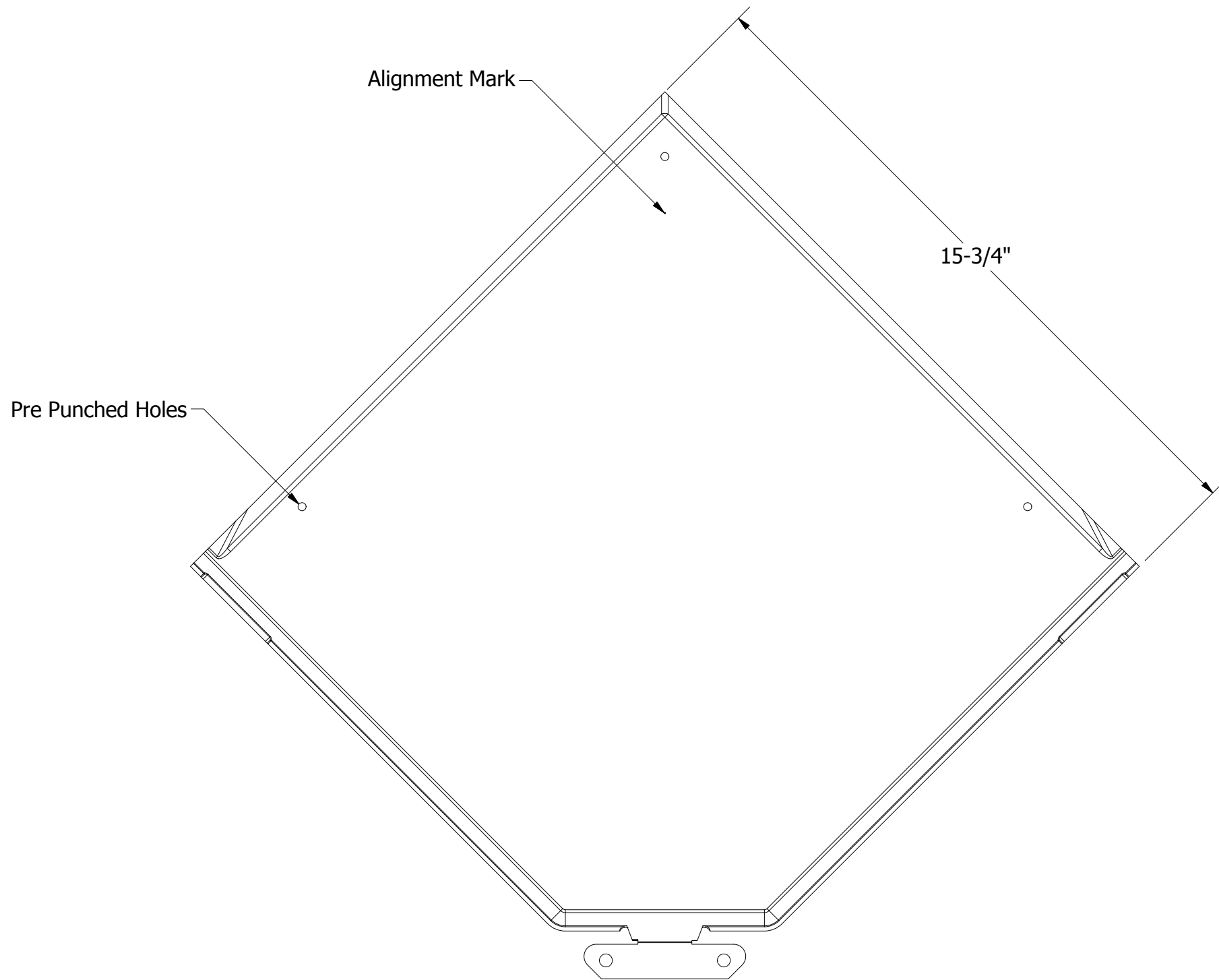

ATAS ATAS INTERNATIONAL, INC
 Allentown PA
 610-395-8445
 Mesa AZ
 480-558-7210

TITLE		CastleTop Panel Profile Detail	
DWG. NO.	DR	KRK	DATE 7/9/2014
	APP		DATE
MATERIAL	SH. SIZE	B	SCALE X:X

REV. NO.	DATE	DESCRIPTION OF REVISION	BY	APP