

Hinge Replacement – Roof Scuttle

HINGE REMOVAL

Tools needed for this procedure: grinder with cutting wheel, hammer and punch, drill with #30 drill bit, ½” socket wrench, vice grip, needle nose pliers

***Note:** The springs and the hold open arm have already been uninstalled before this procedure starts. To do this, consult the Spring Removal Manual before attempting this procedure.

- 1) This procedure begins outside of the closed door.
- 2) First take the grinder with the cutting wheel attached and remove the heads of the bolts. This will detach the hinges from the cover of the door.
(See Figures 1 and 2)



Figure 1



Figure 2

Hinge Replacement – Roof Scuttle

- 3) Once the heads of the bolts have been removed, take a hammer and a punch to knock the rest of the bolt out of the frame. (Figure 3)



Figure 3

- 4) Now you can carefully remove the cover from the frame.
- 5) Using the drill with #30 drill bit, drill the pop-riquet cap off of the pop-riquet. (Figure 4)



Figure 4

Hinge Replacement – Roof Scuttle

- 6) With the pop-rievet cap removed you can now use the hammer and punch to remove the pop-rievet from the hinge pin as shown in Figure 5. If the pop-rievet doesn't fall out it may be necessary to use vice grips to remove it such as in Figure 6.



Figure 5



Figure 6

Hinge Replacement – Roof Scuttle

- 7) Now there is nothing holding the pin of the hinge in place and both the pin and the cover hinge can be removed. (Figure 7)



Figure 7

- 8) To remove the remaining frame hinge attached to the frame, use a ½” socket wrench and take out the bolts. Once this is done the hinge has been completely removed. (Figures 8 & 9)



Figure 8

Hinge Replacement – Roof Scuttle



Figure 9

Hinge Replacement – Roof Scuttle

HINGE INSTALLATION

- 9) To begin the installation of the hinge, first place the frame hinge on the frame of the door. Line up the holes and screw the bolts them into the frame, tightening with the ½” socket wrench. (Figure 10)



Figure 10

- 10) Next attach the cover hinge to the cover with new nuts and bolts. Tighten these with ½” socket wrench as well. (Figures 11 & 12)



Figure 11

Hinge Replacement – Roof Scuttle



Figure 12

11) Lay the cover on top of the frame. (Figure 13)



Figure 13

12) Line up the two parts of the hinges so that the pin can be placed through the hole.

Hinge Replacement – Roof Scuttle

13) With the hinges pinned together you can now open the door. (Figure 14)



Figure 14

14) Rotate the pin so that the hole is facing outward. Now insert the carter pin to make sure the pin doesn't come out of the hinge. (Figure 15)



Figure 15

Hinge Replacement – Roof Scuttle

- 15) Bend the two halves of the carter pin so that they spread out, increasing the security of the pin. (Figure 16)



Figure 16

- 16) You must now reinstall the hold open arm and springs for the door to be fully operational.

Hinge Replacement – Roof Scuttle

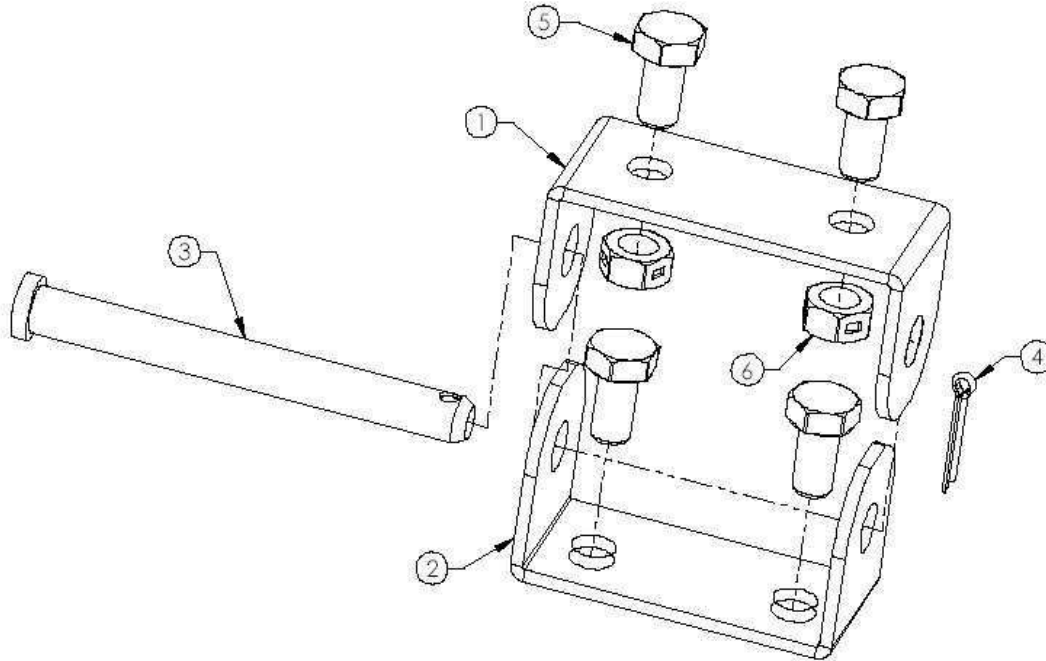

ITEM NO.	PART NO.	DESCRIPTION	QTY.
1	SD13-P	HINGE-R.S. COVER ZINC PLATED	1
2	SD14-P	HINGE-R.S. FRAME ZINC PLATED	1
3	SD12-Y	PIN-SCUTTLE HINGE YELLOW CHRMT	1
4	SD11	COTTER PIN, 1/4 X 2 1/2	1
5	SD27-Y	SCREW-HHCS 5/16"-18 x 5/8" YELLOW CHRMT	4
6	SD18-Y	NUT-HEX LOCK 5/16"-18 YELLOW CHRMT	2