

Bilco LadderUP[®]

SAFETY POST

Installation Instructions

Important: Install only on structurally sound ladder. Use pull-up loop for raising post only, not suitable for attaching a safety harness lanyard.

The Bilco LadderUP safety post is furnished completely assembled for ready attachment to fixed ladder rungs. Included are two (2) channel clamping brackets, four (4) 2" (50mm) stainless steel bolts, and eight (8) stainless steel washers (note: washers are only used when securing to 3/4" (19mm) square or round ladder rungs - see detail below).

- (A) Pull Loop** **(E) Stainless Steel Mounting Bolts**
- (B) Post Release** **(F) Channel Clamping Brackets**
- (C) Spring Nuts** **(G) Coil Spring**
- (D) Instructions** **(H) Washers**

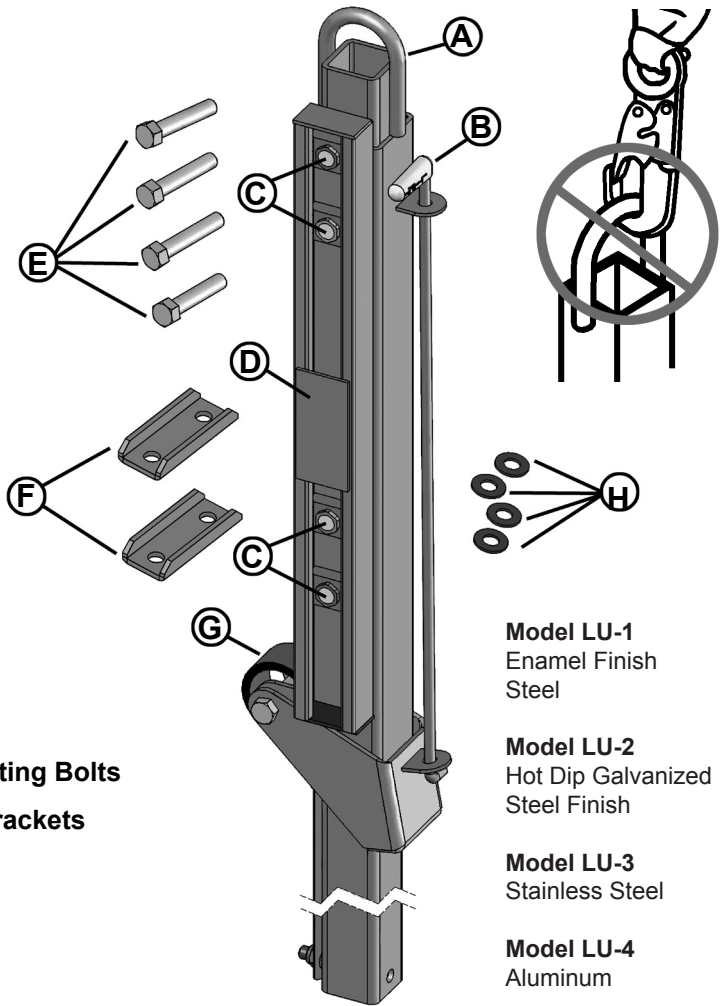

Standard Installation:

It is recommended that two persons install the LadderUP Safety Post

1. Position the LadderUP safety post opposite the climbing side of the ladder as shown below. Note: Spring nuts can be moved to accommodate ladder rung spacing. Simply push in spring nut slightly and slide into position.
2. Determine the diameter of the ladder rungs and secure post to the top two ladder rungs as instructed below using the clamping brackets, bolts and washers provided. Tighten bolts securely.

For 3/4" (19mm) or 1" (25mm) diameter ladder rungs

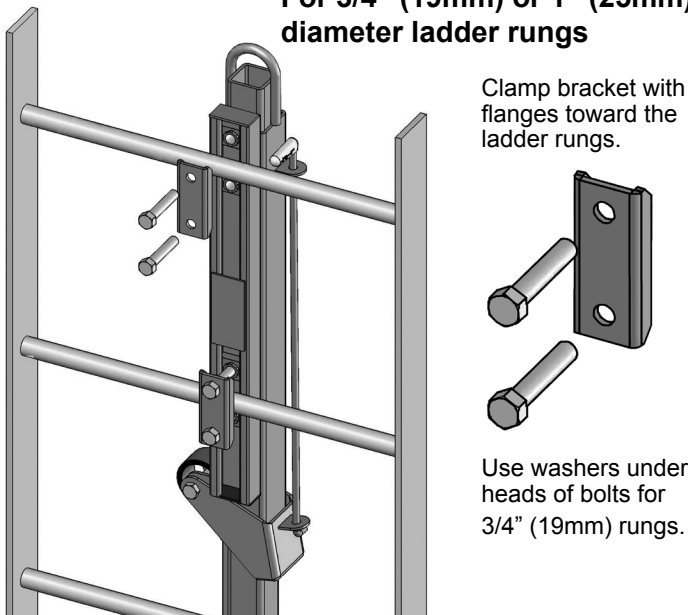

For 1-1/4" (32mm) diameter ladder rungs

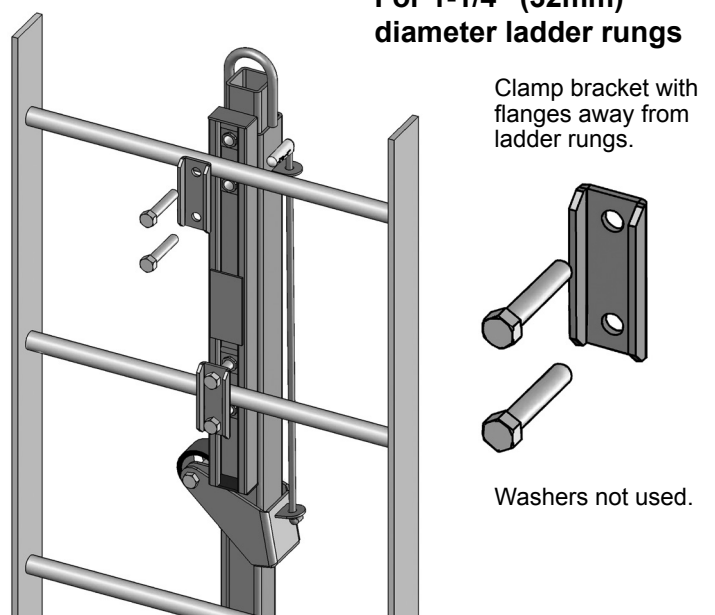

See reverse side for special applications and additional installation methods

Bilco ladderUP[®] SAFETY POST

Installation Instructions

Important: Install only on structurally sound ladder. Use pull-up loop for raising post only, not suitable for attaching a safety harness lanyard.



Special applications and additional installation methods

It is recommended that two persons install the LadderUP Safety Post

Mounting on Hollow Ladder Rungs

On hollow round rung ladders, two pieces of solid aluminum or steel round bar are required to fit inside the rungs. Insert these pieces into the two rungs to which then safety post will be fastened. This will provide additional strength and a solid support to prevent crushing when the bolts are tightened. See reverse side for attachment instructions.

Mounting on Precast Ladder Rungs that are too narrow for a standard installation

Where rungs are installed in precast concrete and the rung spacing is too narrow to permit standard center mounting, the LadderUP Safety Post can be mounted to the side of the rungs as shown below.

1. Position the LadderUP safety post. Note: Spring nuts can be moved to accommodate spacing. Simply push in spring nut slightly and slide into position.
2. Secure the post to the top two ladder rungs using the clamping brackets, bolts and washers provided. Tighten bolts securely.

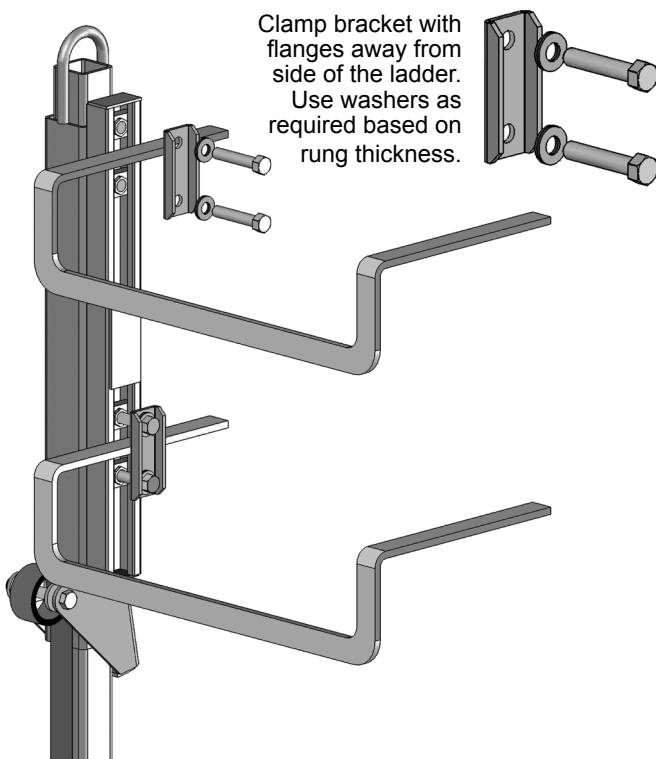

Mounting on the Side of the Ladder

The LadderUP Safety Post may be mounted on one of the fixed ladder rails instead of on the rungs if desired.

1. Position the LadderUP safety post at the top of the ladder rail as shown and mark its location on the ladder.
2. Transfer the hole locations for the safety post spring nuts onto the ladder rail. Note: Spring nuts can be moved if they interfere with a ladder rung. Simply push in spring nut slightly and slide into position.
3. Drill (4) 7/16" (12 mm) diameter holes into the ladder rail.
3. Secure the post to the rail using bolts and washers provided. Tighten bolts securely.

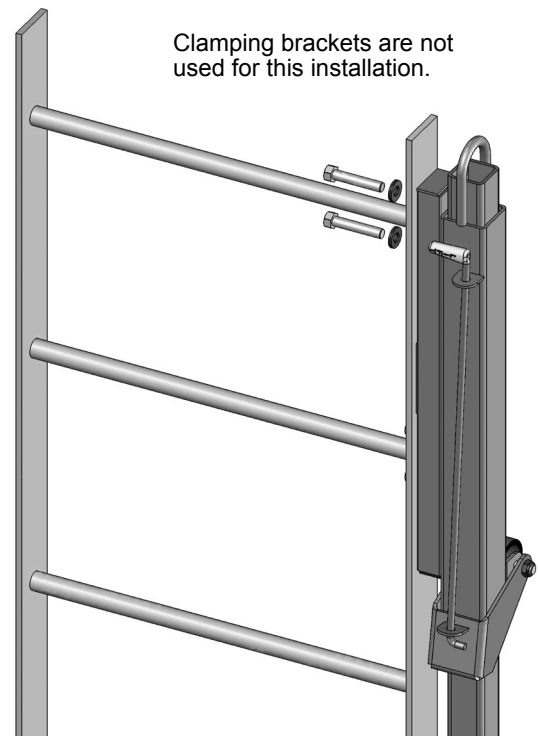

www.bilco.com