



**Boise Cascade**  
Engineered Wood Products

The information in this document pertains to use in the UNITED STATES ONLY. Allowable Stress Design. Refer to the ALLJOIST Specifier Guide Canada for use in Canada, Limit States Design.



# ALLJOIST®

## INSTALLATION GUIDE

Includes AJS®  
140 / 150 / 20 / 190 / 25  
and VERSA-LAM® BEAMS



2x3 Flanges AJS® 140 / 150 / 20 / 190  
2x4 Flanges AJS® 25



## US Version

product manufactured in  
St. Jacques, New Brunswick  
CANADA



### Lifetime Guaranteed Quality and Performance

Boise Cascade warrants its BCI® Joist, VERSA-LAM®, and ALLJOIST® products to comply with our specifications, to be free from defects in material and workmanship, and to meet or exceed our performance specifications for the normal and expected life of the structure when correctly stored, installed, and used according to our Installation Guide.

**Boise Cascade has not evaluated the effects of any pressure or topical applications or treatments on its BCI® Joist, VERSA-LAM®, and ALLJOIST® products.**

For information about Boise Cascade's engineered wood products, including sales terms and conditions, warranties and disclaimers, **visit our website at [www.BCewp.com](http://www.BCewp.com)**

To locate your nearest Boise Cascade Engineered Wood Products distributor, call **1-800-232-0788**

# ALLJOIST® Product Profiles

## AJS® 140

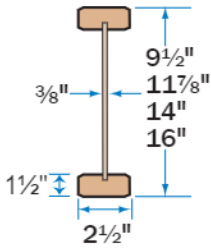

## AJS® 150

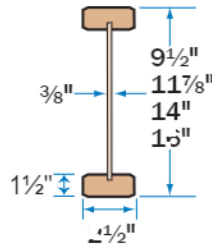

## AJS® 20

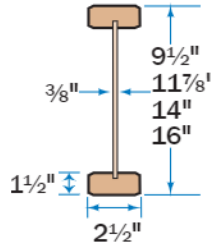

## AJS® 190

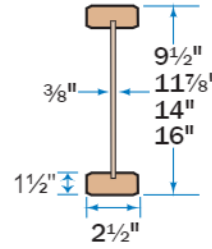

## AJS® 25

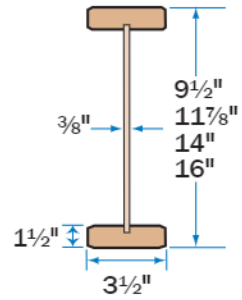

2x3 Flanges

2x4 Flanges



Information on deeper depth AJS® joists is available in the ALLJOIST® Commercial Guide

## AJS® 25 Deeper Depths

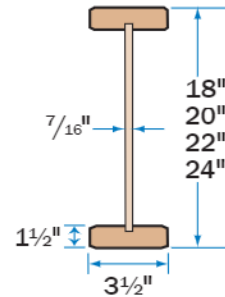

## AJS® 30 Deeper Depths

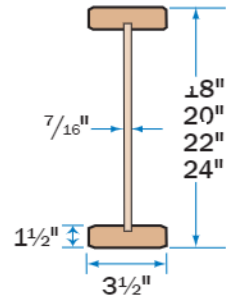

2x4 Flanges

### WARNING

### THE FOLLOWING USES ARE NOT ALLOWED

#### SAFETY WARNING

**DO NOT ALLOW WORKERS ON AJS® JOISTS UNTIL ALL HANGERS, AJS® RIM JOISTS, RIM BOARDS, AJS® BLOCKING PANELS, X-BRACING AND TEMPORARY 1x4 STRUT LINES ARE INSTALLED AS SPECIFIED BELOW. SERIOUS ACCIDENTS CAN RESULT FROM INSUFFICIENT ATTENTION TO PROPER BRACING DURING CONSTRUCTION. ACCIDENTS CAN BE AVOIDED UNDER NORMAL CONDITIONS BY FOLLOWING THESE GUIDELINES:**

- Build a braced end wall at the end of the bay, or permanently install the first eight feet of AJS® Joists and the first course of sheathing. As an alternate, temporary sheathing may be nailed to the first four feet of AJS® Joists at the end of the bay.
- All hangers, AJS® rim joists, rim boards, AJS® blocking panels, and x-bracing must be completely installed and properly nailed as each AJS® Joist is set.
- Install temporary 1x4 strut lines at no more than eight feet on center as additional AJS® Joists are set. Nail the strut lines to the sheathed area, or braced end wall, and to each AJS® Joist with two 8d nails.

**DO NOT** notch or drill beams without prior approval from Boise Cascade EWP Engineering.

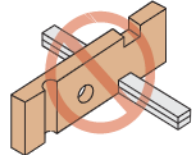

**DO NOT** cut beyond inside edge of bearing.

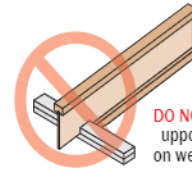
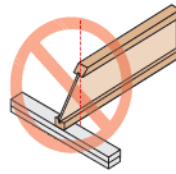

**DO NOT** support joist on web.

**DO NOT** cut holes too close to supports or to each other.

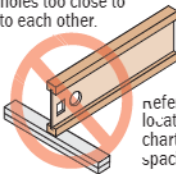

Refer to hole location and spacing chart for size and spacing.

**DO NOT** nail closer than 1 1/2" from end of joist.

**DO NOT** use 16d common nails.

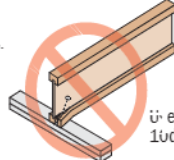

Use 8d nails or 16d/16u box nails

**DO NOT** cut or notch flange.

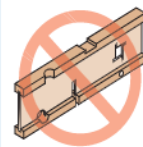

See roof and floor details, this sheet, for allowed cutting of flange.

**DO NOT** walk on joist until proper bracing is in place.

**DO NOT** load joist beyond design capacity.

**DO NOT** stack building materials on unbraced joists.



**DO NOT** install tongue of floor sheathing flush with either 1" or 1 1/2" thick BOISE CASCADE® rim board (tongue OK w/1 1/2" and thicker BOISE CASCADE® rim board).

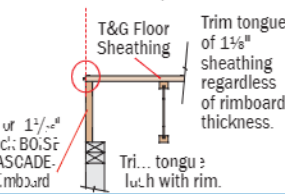
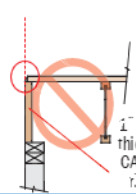

Trim tongue of 1 1/2" sheathing regardless of rimboard thickness.

Trim tongue flush with rim.

**DO NOT** hammer on web unless removing knockout holes.

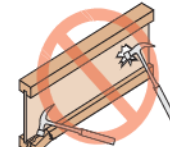

**DO NOT** hammer on flange.

- The ends of cantilevers must be temporarily secured by strut lines on both the top and bottom flanges.
- Straighten the AJS® Joists to within 1/2 inch of true alignment before attaching strut lines and sheathing.
- Remove the temporary strut lines only as required to install the permanent sheathing.
- Failure to install temporary bracing may result in sideways buckling or roll-over under light construction loads
- DO NOT stack construction materials (sheathing, drywall, etc) in the middle of AJS® Joist spans, contact Boise Cascade EWP Engineering for proper storage and shoring information.



## About Floor Performance

Homeowner's expectations and opinions vary greatly due to the subjective nature of raising a new floor. Communication with the ultimate end user to determine their expectation is critical. **Vibration** is usually the cause of most complaints. Installing lateral bridging may help; however, squeaks may occur if not installed properly. Spacing the joists closer together does little to affect the perception of the floor's performance. The most common methods used to increase the performance and reduce vibration of wood floor systems is to

**increase the joist depth, limit joist deflections, glue and screw a thicker tongue-and-groove subfloor, install the joists vertically, subfloor with level-bearing supports and install a direct-attached ceiling to the bottom flanges of the joists.**

The floor span tables listed below offer three very different performance options, based on performance requirements of the homeowner.

Joist Depth	ALLJOIST® Series	★★★.THREE STAR★★★				★★★★FOUR STAR★★★★				C-SECTION		★MINIMUM STIFFNESS ALLOWED BY CODE★		CAUTION			
		12" o.c.	16" o.c.	19.2" o.c.	24" o.c.	12" o.c.	16" o.c.	19.2" o.c.	24" o.c.	12" o.c.	16" o.c.	19.2" o.c.	24" o.c.	Live Load deflection limited to L/330: Floors that meet the minimum building code L/360 criteria are structurally sound to carry the specified loads; however, there is a much higher risk of floor performance issues. This table should only be used for applications where floor performance is not a concern.			
1 1/2"	140	17'-9"	16'-3"	15'-4"	14'-11"	13'-11"	12'-8"	11'-11"	11'-1"	19'-8"	17'-0"	15'-6"	13'-11"	Live Load deflection limited to L/450: This common industry and design community standard for residential floor joists, 53% stiffer than L/360 code minimum. However, floor performance may still be an issue in certain applications, especially with 9 1/2" and 11 7/8" deep joists without a direct-attached ceiling.			
	150	18'-1"	16'-7"	15'-8"	14'-7"	14'-2"	12'-11"	11'-2"	11'-3"	20'-0"	15'-3"	16'-8"	14'-11"				
	20	19'-1"	17'-5"	16'-0"	15'-4"	14'-10"	13'-6"	12'-9"	11'-10"	21'-1"	19'-3"	13'-2"	16'-4"				
	190	19'-4"	17'-8"	16'-8"	15'-6"	15'-1"	13'-9"	12'-11"	12'-0"	21'-4"	19'-7"	16'-6"	17'-3"				
	25	21'-0"	19'-1"	18'-0"	16'-9"	16'-4"	14'-10"	14'-0"	12'-11"	23'-2"	21'-1"	19'-3"	17'-2"				
1 7/8"	140	21'-2"	19'-4"	17'-8"	15'-10"	16'-7"	15'-1"	14'-3"	13'-3"	22'-5"	19'-5"	17'-8"	15'-10"				
	150	21'-7"	19'-8"	18'-7"	17'-0"	16'-10"	15'-4"	14'-6"	13'-5"	23'-10"	20'-10"	19'-0"	17'-0"				
	20	22'-8"	20'-9"	19'-7"	18'-3"	17'-9"	16'-2"	15'-2"	14'-1"	25'-1"	22'-10"	20'-10"	18'-8"				
	190	23'-0"	21'-0"	19'-10"	18'-6"	18'-0"	16'-4"	15'-5"	14'-4"	25'-5"	23'-3"	21'-11"	19'-0"				
	25	24'-11"	22'-9"	21'-5"	18'-3"	19'-6"	17'-8"	16'-8"	15'-5"	27'-3"	24'-0"	21'-11"	18'-3"				
2"	140	24'-0"	21'-4"	19'-5"	17'-4"	18'-10"	17'-2"	16'-2"	15'-0"	24'-3"	21'-4"	19'-5"	17'-4"				
	150	24'-6"	22'-4"	20'-11"	18'-9"	19'-2"	17'-6"	16'-5"	15'-3"	26'-6"	22'-11"	20'-11"	18'-9"				
	20	25'-9"	23'-6"	22'-2"	19'-1"	20'-2"	18'-4"	17'-3"	16'-0"	28'-5"	25'-1"	22'-11"	19'-1"				
	190	26'-1"	23'-10"	22'-6"	19'-1"	20'-5"	18'-7"	17'-6"	16'-3"	28'-10"	26'-4"	23'-11"	19'-1"				
	25	28'-4"	25'-10"	22'-11"	18'-4"	22'-1"	20'-1"	18'-11"	17'-6"	30'-5"	26'-4"	22'-11"	18'-4"				
2 1/2"	140	26'-6"	22'-11"	20'-11"	18'-9"	20'-10"	19'-0"	17'-11"	16'-8"	26'-6"	22'-11"	20'-11"	18'-9"				
	150	27'-1"	24'-7"	22'-5"	19'-3"	21'-3"	19'-4"	18'-3"	16'-11"	28'-5"	24'-7"	22'-5"	19'-3"				
	20	28'-6"	26'-0"	24'-2"	19'-3"	22'-4"	20'-4"	19'-1"	17'-9"	31'-3"	27'-0"	24'-2"	19'-3"				
	190	28'-11"	26'-5"	24'-2"	19'-3"	22'-8"	20'-7"	19'-5"	18'-0"	31'-11"	28'-11"	24'-2"	19'-3"				
	25	31'-4"	27'-10"	23'-2"	18'-6"	24'-6"	22'-3"	20'-11"	18'-6"	32'-9"	27'-10"	23'-2"	18'-6"				

- Table values based on residential floor loads of 40 psf live load and 10 psf dead load (12 psf dead load for AJS® 25 joists).
- Table values assume that 1/2" thick plywood/OSB rated sheathing is glued and nailed to joists.
- Table values represent the most restrictive or simple or multiple span applications.
- Table values are the maximum allowable clear distance between supports. Analyze multiple span joists with BC CALC sizing software if the length of any span is less than half the length of an adjacent span.
- Table values assume minimum bearing lengths without web stiffeners for joist depths of 1 1/2 inches and less.

- Floor tile will increase dead load and may require specific deflection limits, contact Boise Cascade EWP Engineering for further information
- This table was designed to apply to a broad range of applications. It may be possible to exceed the limitations of this table by analyzing a specific application with the BC CALC® sizing software.

Shaded values do not satisfy the requirements of the North Carolina State Building Code. Refer to the THREESTAR table when spans exceed 20 feet.

## One-Hour Floor/Ceiling Assembly

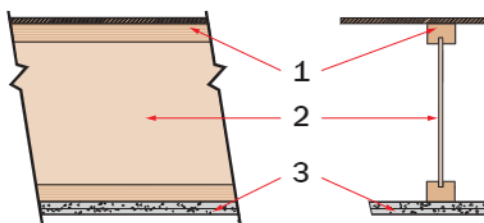

See the US version of the Boise Cascade Fire Design & Installation Guide for specific assembly information and other fire resistive options or contact your local Boise Cascade representative.

### FIRE ASSEMBLY COMPONENTS

1. Min. 1/2-inch T&G Wood Structural Panels. A construction adhesive must be applied to the top of the joists prior to placing sheathing. The sheets shall be installed with their long edge perpendicular to the joists with end joints centered over the top flange of joists and staggered one joist spacing with adjacent sheets.
2. AJS® Joists at 24" o.c. or less.
3. Two layers 1/2" Type C or two layers 5/8" Type X gypsum board

### SOUND ASSEMBLY COMPONENTS

When constructed with resilient channels

- Add carpet & pad to fire assembly;
- Add 3 1/2" glass fiber insulation to fire assembly;
- Add an additional layer of minimum 5/8" sheathing and 9 1/2" glass fiber insulation to fire assembly;

STC=54	IIC=68	or
STC=55	IIC=46	
STC=61	IIC=50	

# Floor Framing

Additional roof framing details available with BC FRAMER® software

**NOTE**

The illustration below is showing several suggested applications for the Boise Cascade EWP products with treated wood. It is not intended to show an actual house under construction.

**NO MIDSPAN BRIDGING IS REQUIRED FOR ALLJOIST® PRODUCT**

**FOR INSTALLATION STABILITY**  
Temporary strut lines (max. min.) 8' on center max. Fasten at each joist with 2-8d nails minimum.

Dimension lumber is not suitable for use as a rim board in ALLJOIST® floor systems.

AJS® rim joist. See Floor Details page 5.

F01 F02

F07  
BOISE CASCADE® Rimboard. See pages 6 and 27 of the ALLJOIST® Specifier Guide.

For load-bearing cantilever details, see page 9.

F06 AJS® blocking or 2x4 "squash" block on each side required when supporting a load-bearing wall above.  
F09

When installing Boise Cascade EWP products with treated wood, use only connectors/fasteners that are approved for use with the corresponding wood treatment.

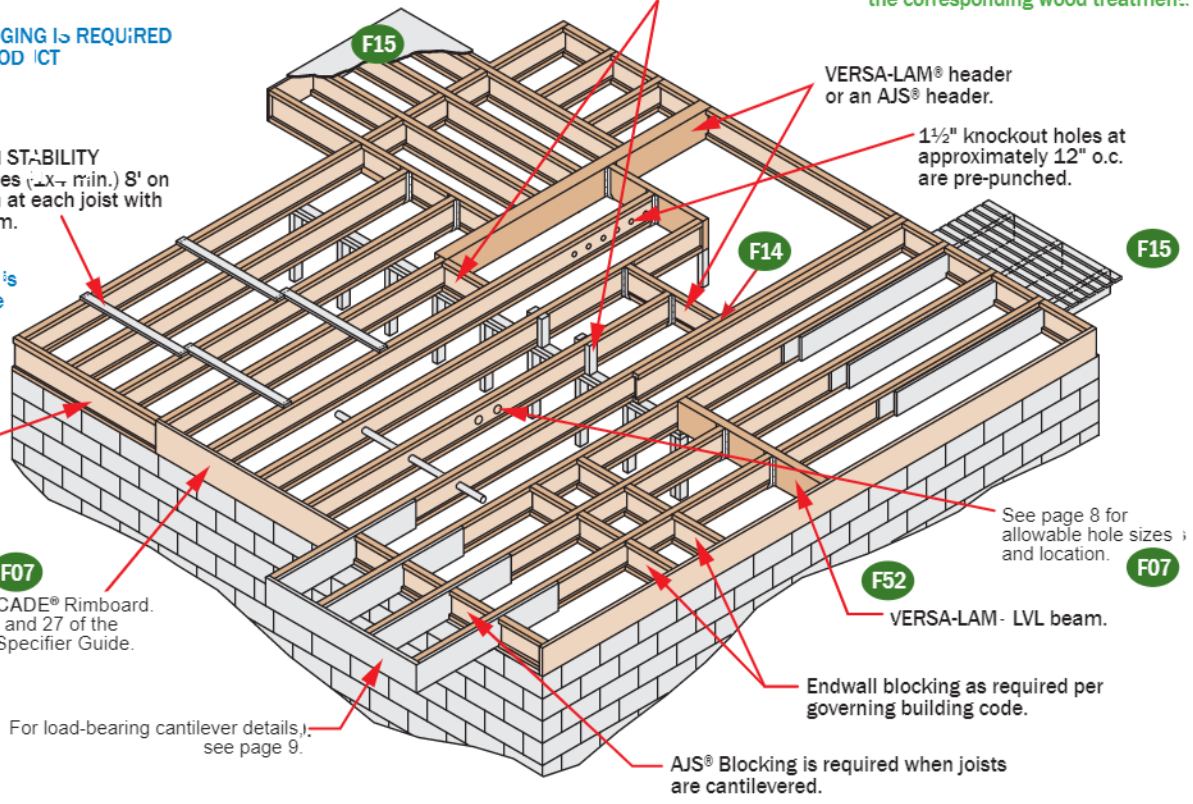

## Web Stiffener Requirements

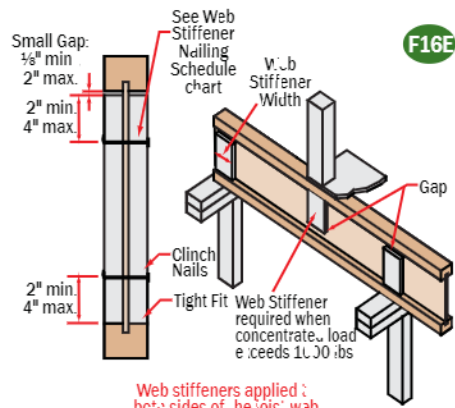

Web stiffeners applied to both sides of the joist web

Web Stiffener Nailing Schedule

AJS® Series	Joist Depth	Nailing	
140 150 20	3½" - 11¾"	3-10d	
190 25			14" - 16"

**NOTES**

- Web stiffeners are optional except as noted below.
- Web stiffeners are always required for 18" and deeper AJS® joists at all bearing locations.
- Web stiffeners are always required in hangers that do not extend up to support the top flange of the AJS® Joist. Web stiffeners may be required with certain sloped or skewed hangers or to achieve uplift values. Refer to the hanger manufacturer's installation requirements.
- Web stiffeners are always required in certain roof applications. See *Roof Framing Details* on page 7.
- Web stiffeners are always required under concentrated loads that exceed 1000 pounds. Install the web stiffeners snug to the top flange in this situation. Follow the nailing schedule for intermediate bearings.
- Web stiffeners may be used to increase allowable reaction values. See *AJS® Design Properties* on page 26 of the ASG or the BC CALC® software.

Structural Panel Web Stiffener

AJS® Series	Minimum Thickness		Minimum Width
	In Hanger	No Hanger	
140 / 150 / 20 / 190	1"	1½"	2 <sup>5</sup> / <sub>16</sub> "
25	2x4 lumber (vertical)		



Additional floor framing details available with BC FRAMER® software

## END BEARING DETAILS

**F07**

Full Boise CASCADE® Rimboard. Pinned and to AJS® Joists with 2d nails in end flange. Dimension lumber is not suitable for use as rim board with AJS® Joists.

**F07A**

Dimension lumber is not suitable for use as rim board with AJS® Joists. Blocking may be required perpendicular to wall, consult design professional of record a/d/or local building official.

**F07B**

2x\_ ledger.

**F02**

AJS® rim joist. Use of AJS® rimjoist requires 2x6 wall for minimum joist bearing.

**F01**

AJS® blocking.

**F27A**

Top Flange or Face Mount Joist Hanger. VERSA-LAM®

**F52**

One 8d nail each side at bearing. 1 1/2" minimum bearing length (1 3/4" required for 18" and deeper joists). To limit splitting flange, start nails at least 1 1/2" from end. Nails may need to be driven at an angle to limit splitting of bearing plate.

**F08**

Solid block all posts from above to bearing below.

**F03**

BOISE CASCADE® Rimboard. Note: AJS® floor joist must be designed to carry wall above when not stacked over wall below. Blocking required underneath braced wall panels and shear walls, consult design professional of record.

## INTERMEDIATE BEARING DETAILS

**F06**

AJS® Joist blocking. For load bearing wall above (stacked over wall below).

**F09**

Load bearing wall above (stacked over wall below). 1/4" gap. Nail block with one 10d nail into each flange.

**F10**

Backer block (minimum 12" wide). Nail with 10 - 10d nails. Filler block. Nail with 10 - 10d nails. Backer block required where top flange joist hanger load exceeds 250 lbs. Install tight to top flange.

**F58**

Double AJS® Joist Connection. Filler Block (see chart below). Web-Filler Nailing 12" on-center. Connection valid for all applications. Contact Boise Cascade EWP Engineering for specific conditions.

**F05**

Sheathing or rimboard closure. AJS® blocking required for cantilever. For load bearing cantilever, see pages 9 and 10. Uplift on backspan shall be considered in all cantilever designs.

**F14**

AJS® Joist Slope Cut Reinforcement. Detail used to restore original allowable shear/reaction value to cut end of AJS® joist. AJS® Joist shall not be used as a collar or rafter tension tie. 2x3 min. rafter. Rafter shall be supported by ridge beam or other bearing support. 6 min. 12. 16" max. AJS® depth. Heel Depth (see table below). 24". 2" blocking required at bearing (not shown for clarity). 3/4" min. plywood, OSB rated sheathing as reinforcement. Install reinforcement with 10d gage in horizontal. Install on bottom flange of the joist tight to bottom flange. 1/4" gap between reinforcement and bottom of top flange. Apply construction adhesive to contact surfaces and fasten with 3 rows of min. 10d box nails at 6" o.c. Alternate nailing from each side and clinch.

End Wall Bearing	Minimum Heel Depth					
	6/12	7/12	8/12	9/12	10/12	2/12
2 x 4	4 3/8"	4 3/8"	4 3/4"	4 3/4"	4 3/4"	4 3/4"
2 x 6	3 3/4"	3 3/4"	2 3/4"	2 3/4"	2 3/4"	2 3/4"

Size	Joist Spacing [in]			
	12	16	19.2	24
2x4	1347	1347	1183	2251
2x6	7013	5251	4363	3106

1. Joist blocking is to be installed in contact with upper floor and lower wall plate.  
2. Capacities shown are for a double squash blocks at each joist, SPP on center.

## LATERAL SUPPORT

- AJS® Joists must be laterally supported at the ends with hangers, AJS® rim joists, rim boards, AJS® blocking panels or bracing. AJS® blocking panels or bracing are required at cantilever supports.
- Blocking may be required at intermediate bearings for floor diaphragm per IRC in high seismic areas, consult local building official.

## MINIMUM BEARING LENGTH FOR AJS® JOISTS

- 1 1/2 inches is required at end supports. 3 1/2 inches is required at cantilever and intermediate supports.
- Longer bearing lengths allow higher reaction values. Refer to the building code evaluation report or the EFCALC® software.

## NAILING REQUIREMENTS

- AJS® rim joist, rim board or closure panel to AJS® Joist:
  - Rims or closure panel 1 1/2 inches thick and less: 2-8d nails, one each in the top and bottom flange.
  - AJS® 140/150/20/190 rim joist: 2-16d box nails, one each in the top and bottom flange
  - AJS® 25 rim joist. Toe-nail top flange to rim joist with 2 10d box nails, one each side of flange.
- AJS® rim joist, rim board or AJS® blocking panel to support.
  - 2d nails at 6 inches on center.
  - When used for shear transfer, follow the building designer's specification.

## AJS® Joist to support.

- 2-8d nails, one on each side of the web, placed 1 1/2 inches minimum from the end of the AJS® Joist to limit splitting
- Sheathing to AJS® joist, rim joist, blocking:
  - Prescriptive residential floor sheathing nailing requires 8d common nails @ 6" o.c. on edges and @ 12" o.c. in the field IRC Table R602.3(1). Closer nail spacing may be required per design professional of record.
  - 14 gauge staples may be substituted for 8d nails if the staples penetrate at least 1 inch into the joist.
  - Wood screws may be acceptable, contact local building official and/or Boise Cascade EWP Engineering for further information.

## BACKER AND FILLER BLOCK DIMENSIONS

AJS® Series	Backer Block Thickness	Filler Block Thickness
140	1 1/2" or two 1/2" wood panels	2x_ + 5/8" wood panel
150		
20		
190		
25	2x_ lumber	Double 2x_ lumber

- Cut backer and filler blocks to a maximum depth equal to the web depth minus 1/4" to avoid a forced fit.
- For deeper AJS® Joists, stack 2x lumber or use multiple pieces of 3/4" wood panels.

## WEB STIFFENER REQUIREMENTS

- See *Web Stiffener Requirements* on page 4.

## PROTECT AJS® JOISTS FROM THE WEATHER

- AJS® Joists are intended only for applications that provide permanent protection from the weather. Bundles of product should be covered and stored off of the ground on stickers.

## AJS® RIM JOISTS AND BLOCKING

Joist Depth	Vertical Load Transfer Capacity (plf)
9 1/2"	1875
11 3/8"	1680
14"	1500
16"	1340

- 1) Web stiffeners required at each end of blocking panel. Distance between stiffeners must be less than 24".

## AJS® Rafters

Additional roof framing details available with BC FRAME® software

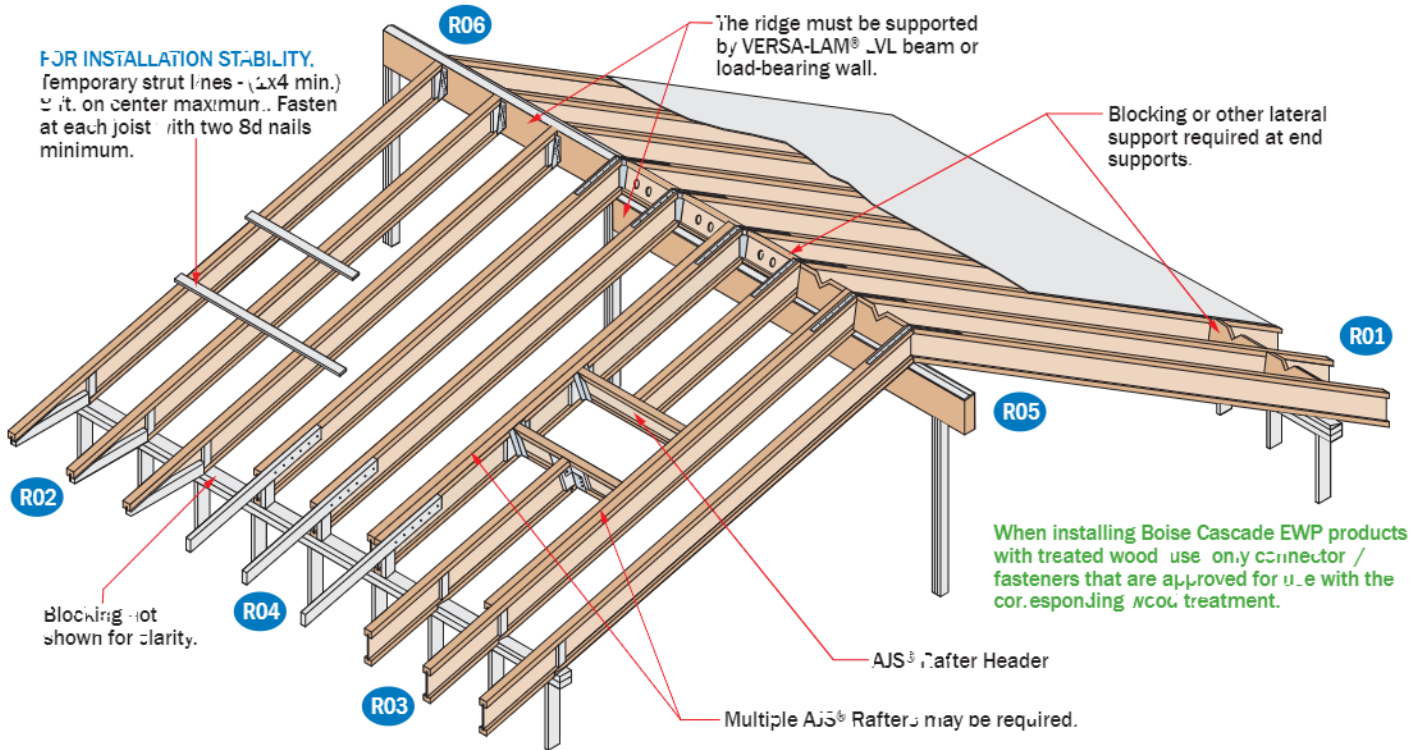

### SAFETY WARNING

**DO NOT ALLOW WORKERS ON AJS® JOISTS UNTIL ALL HANGERS, AJS® RIM JOISTS, RIM BOARDS, AJS® BLOCKING PANELS, X-BRACING AND TEMPORARY 1x4 STRUT LINES ARE INSTALLED AS SPECIFIED BELOW.**

**SERIOUS ACCIDENTS CAN RESULT FROM INSUFFICIENT ATTENTION TO PROPER BRACING DURING CONSTRUCTION. ACCIDENTS CAN BE AVOIDED UNDER NORMAL CONDITIONS BY FOLLOWING THESE GUIDELINES:**

- Build a braced end wall at the end of the bay, or permanently install the first eight feet of AJS® Joists and the first course of sheathing. As an alternate, temporary sheathing may be nailed to the first four feet of AJS® joists at the end of the bay.
- All hangers, AJS® rim joists, rim boards, AJS® blocking panels, and bracing must be completely installed and properly nailed as each AJS® Joist is set
- Install temporary 1x4 strut lines at no more than eight feet on center as additional AJS® Joists are set. Nail the strut lines to the sheathed area, or braced end wall, and to each AJS® Joist with two 8d nails.

- The ends of cantilevers must be temporarily secured by strut lines on both the top and bottom flanges.
- Straighten the AJS® Joist to within 1/2 inch of true alignment before attaching strut lines and sheathing.
- Remove the temporary strut lines only as required to install the permanent sheathing.
- Failure to install temporary bracing may result in sideways buckling or roll-over under light construction loads

### AJS® Ceiling Joist with Level End Cut (For Limited-Access Attics Only)

**AJS® Joist shall not be used as collar/tension tie. Roof rafter shall be supported by ridge beam or other upper bearing support.**

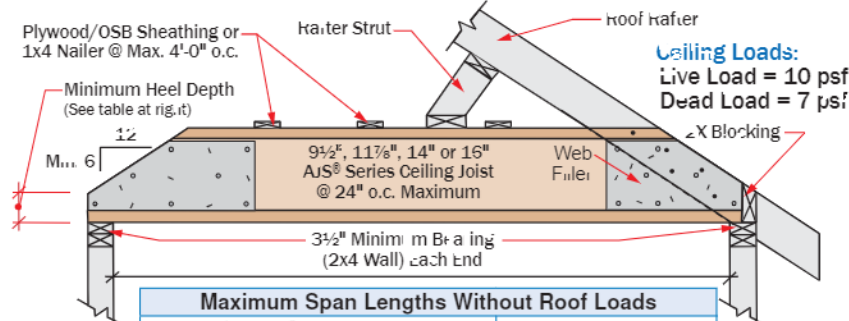

If roof loads transfer to ceiling joists through struts, analyze with BC CALC® software, not exceeding end reaction limit stated in Note 2 (see right).

Minimum Heel Depths	Joist Depth	End Wall	
		2 x 4	2 x 6
9 1/2"	9 1/2"	2 1/2"	1 1/2"
11 7/8"	11 7/8"	3 1/2"	2 1/2"
14"	14"	4 1/2"	3 1/2"

#### Notes:

- Detail is to be used only for ceiling joists with no access to attic space.
- Ceiling joist must be designed to carry all roof load transferred through rafter struts as shown.
- AJS® ceiling joist end reaction may not exceed 550 pounds.
- Minimum roof slope is 7/12.
- Nail roof rafter to AJS® top flange with 1-16d sinker or box nail.
- 1x4 nails shall be continuous and nailed to an end wall braced to the roof diaphragm.
- Install a 24" long web stiffener on each side of AJS® Joist at beveled ends. Nail roof rafter to AJS® Joist per building code requirements for ceiling joist to roof rafter connection.



## Additional roof framing details available with BC FRAMER® software

**R01**

2x beveled plate for slope greater than 7/12.

Simpson VPA or USP TMP connectors or equal can be used in lieu of beveled plate for slopes from 3/12 to 12/12.

**R04**

10d nails at 6" o.c.

2x4 one side for 135 PLF max.  
2x6 one side for 240 PLF max.

Backer block. Thickness per corresponding AJS® series.

2x block

AJS® blocking Holes cut for ventilation.

4'-0" horiz.

2'-6" horiz.

**R02**

Rimboard / VERSA-LAM® blocking. Ventilation "V" cut: 1/3 of length, 1/2 of depth

2x4 blocking for soffit support.

2'-6" max.

Flange of AJS® Joists may be birdsmouth cut only at the low end of the joist. Birds-mouth cut AJS® joist must bear fully on plate, web stiffener required each side. Bottom flange shall be fully supported

**DN05**

**DO NOT** bevel-cut joist beyond inside face of wall, except for specific conditions in details shown on pages 6 and 15 of the ALLJOIST® Specifier Guide.

**R03**

Rimboard / VERSA-LAM® blocking. Ventilation "V" cut: 1/3 of length, 1/2 of depth

Tight fit for lateral stability.

Flange of AJS® Joists may be birdsmouth cut only at the low end of the joist. Birds-mouth cut AJS® Joist must bear fully on plate, web stiffener required each side.

2'-6" max.

**R07**

Backer block (minimum 12" wide). Nail with 10-10d nails

Joist Hanger

Filler block. Nail with 10-10d nails

Backer block required where top flange joist hanger load exceeds 250 lbs. Install tight to top flange

**R05**

Simpson or USP LSTA24 strap, nailing per governing building code.

AJS® Blocking: Row on each side of ridge or alternate. Holes cut for ventilation.

VERSA-LAM® LVL support beam.

Double-beveled plate, connect to ridge with 2 rows 10d nails at 12" o.c.

**R06**

Simpson or USP LSTA24 strap where slope exceeds 7/12 (straps may be required for lower slope, in high-wind areas). Nailing per governing building code.

VERSA-LAM® LVL support beam.

Beveled web stiffener on each side.

Simpson LSSUI or USP TMU hanger.

**R11**

Double joist may be required when L exceeds rafter spacing.

Blocking as required.

Nail outrigger through AJS® web.

2" x outrigger notched around AJS® top flange. Outrigger spacing no greater than 24" on-center.

End Wall.

L (L=0" max.)

### LATERAL SUPPORT

- AJS® Joists must be laterally supported at the ends with hangers, AJS® rim joists, rim boards, AJS® blocking panels or x-bracing. AJS® blocking panels or x-bracing are required at cantilevers, joints
- Blocking may be required at intermediate bearings for floor diaphragm per IRC in high seismic areas, consult local building official.

### MINIMUM BEARING LENGTH FOR AJS® JOISTS

- 1½ inches is required at end supports. 3½ inches is required at cantilever and intermediate supports.
- Longer bearing lengths allow higher reaction values. Refer to the building code evaluation report or the BC CALC® software.

### NAILING REQUIREMENTS

- AJS® rim joist, rim board or closure panel to AJS® Joist:
  - Rims or closure panel 1½ inches thick and less: 2-8d nails, one each in the top and bottom flange.
  - AJS® 140/150/20/190 rim joist: 2-16d box nails, one each in the top and bottom flange.
  - AJS® 25 rim joist: Toe-nail top flange to rim joist with 2-10d box nails, one each side of flange
- AJS® rim joist, rim board or AJS® blocking panel to support:
  - 8d nails at 6 inches on center.
  - When used for shear transfer, follow the building designer's specification.

### BACKER AND FILLER BLOCK DIMENSIONS

- AJS® Joist to support:
  - 2-8d nails, one on each side of the web, placed 1½ inches minimum from the end of the AJS® Joist to limit splitting.
- Sheathing to AJS® joist, rim joist, blocking:
  - Prescriptive residential roof sheathing nailing requires 8d common nails @ 6" o.c. on edges and @ 12" o.c. in the field IRC table R602.3(1). Closer nail spacing may be required per design professional of record.
  - 14 gauge staples may be substituted for 8d nails if the staples penetrate at least 1 inch into the joist.
  - Wood screws may be acceptable, contact local building official and/or Boise Cascade EWP Engineering for further information.

### BACKER AND FILLER BLOCK DIMENSIONS

AJS® Series	Backer Block Thickness	Filler Block Thickness
140		
150	1½" or two ½"	2x ½" wood panel
20		
190		
25	2x lumber	Double 2x lumber

- Cut backer and filler blocks to a maximum depth equal to the web depth minus ¼" to avoid a forced fit.
- For deeper AJS® Joists, stack 2x lumber or use multiple pieces of ¾" wood panels.

### WEB STIFFENER REQUIREMENTS

- See *Web Stiffener Requirements* on page 4.

### PROTECT AJS® JOISTS FROM THE WEATHER

- AJS® Joists are intended only for application that provide permanent protection from the weather. Builders of AJS® Joists should be covered and stored off of the ground on stickers.

### MAXIMUM SLOPE

- Unless otherwise noted, all roof details are valid for slopes of 12 in 12 or less.

### VENTILATION

- The ½ inch, pre-stamped knock-out holes spaced at 12 inches on center along the AJS® Joist may all be knocked out and used for cross ventilation. Deeper joists than what is structurally needed may be advantageous in ventilation design. Consult local building official and/or ventilation specialist for specific ventilation requirements.

### BIRDSMOUTH CUTS

- AJS® Joists may be birdsmouth cut only at the low end support. AJS® Joists with birdsmouth cuts may cantilever up to 2'-6" past the low end support. The bottom flange must sit fully on the support and may not overhang the inside face of the support. High end supports and intermediate supports may not be birdsmouth cut.

# AJS® Joist Hole Location & Sizing

AJS® Joists are manufactured with 1½" round perforated knockouts in the web at approximately 12" on center

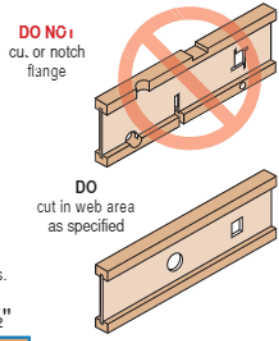
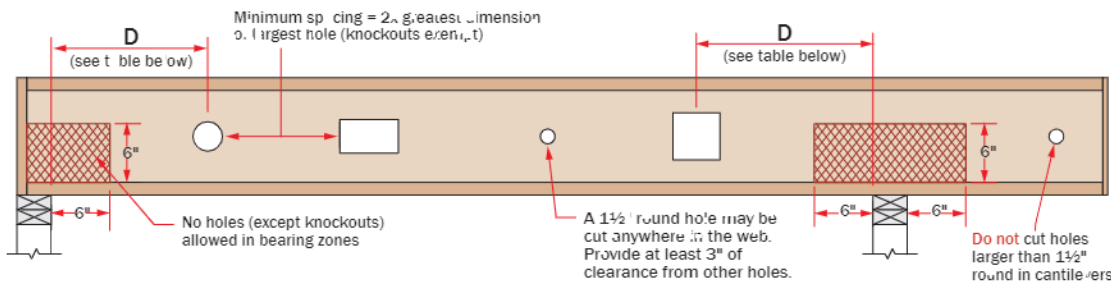

Minimum distance from support, listed in table below, is required for all holes greater than 1½"

MINIMUM DISTANCE (D) FROM ANY SUPPORT TO THE CENTERLINE OF THE HOLE

Round Hole Diameter [in]		2	3	4	5	6	6½	7	8	8¾	9	10	11	12	13	
Rectangular Hole Side [in]		-	-	2	4	6	6	-	-	-	-	-	-	-	-	
Any 1½" Joist	Span [ft]	8	2'-0"	2'-5"	2'-11"	3'-5"	3'-10"	4'-0"								
		12	3'-0"	3'-6"	4'-5"	5'-1"	5'-10"	6'-0"								
		13	4'-0"	4'-11"	5'-11"	6'-10"	7'-9"	8'-0"								
Round Hole Diameter [in]		2	3	4	5	6	6½	7	8	8¾	9	10	11	12	13	
Rectangular Hole Side [in]		-	-	-	2	3	4	5	7	8	-	-	-	-	-	
Any 17/8" Joist	Span [ft]	8	1'-0"	1'-3"	1'-10"	2'-3"	2'-8"	2'-11"	3'-1"	3'-6"	3'-11"					
		12	1'-5"	2'-1"	2'-9"	3'-5"	4'-0"	4'-4"	4'-8"	5'-4"	5'-11"					
		16	1'-11"	2'-10"	3'-8"	4'-6"	5'-5"	5'-10"	6'-3"	7'-1"	7'-10"					
		20	2'-5"	3'-6"	4'-11"	5'-8"	6'-9"	7'-3"	7'-10"	8'-11"	9'-10"					
Round Hole Diameter [in]		2	3	4	5	6	6½	7	8	8¾	9	10	11	12	13	
Rectangular Hole Side [in]		-	-	-	-	2	3	3	5	6	6	8	9	-	-	
Any 14" Joist	Span [ft]	8	1'-0"	1'-1"	1'-2"	1'-4"	1'-8"	1'-11"	2'-1"	2'-6"	2'-10"	2'-11"	3'-4"	3'-11"		
		12	1'-0"	1'-1"	1'-4"	2'-0"	2'-7"	2'-11"	3'-2"	3'-10"	4'-4"	4'-5"	5'-0"	5'-7"		
		16	1'-0"	1'-1"	1'-10"	2'-0"	2'-5"	3'-10"	4'-3"	5'-1"	5'-9"	5'-11"	6'-8"	7'-6"		
		20	1'-0"	1'-3"	2'-4"	3'-4"	4'-4"	4'-10"	5'-4"	6'-4"	7'-3"	7'-4"	8'-5"	9'-5"		
		24	1'-0"	1'-7"	2'-9"	4'-0"	5'-2"	5'-10"	6'-5"	7'-8"	8'-8"	8'-10"	10'-1"	11'-3"		
Round Hole Diameter [in]		2	3	4	5	6	6½	7	8	8¾	9	10	11	12	13	
Rectangular Hole Side [in]		-	-	-	-	-	-	2	3	5	5	6	8	9	10	
Any 16" Joist	Span [ft]	8	1'-0"	1'-1"	1'-2"	1'-2"	1'-3"	1'-3"	1'-3"	1'-8"	2'-0"	2'-1"	2'-5"	2'-10"	3'-2"	3'-7"
		12	1'-0"	1'-1"	1'-2"	1'-2"	1'-4"	1'-8"	1'-11"	2'-6"	3'-0"	3'-1"	3'-8"	4'-3"	4'-10"	5'-5"
		16	1'-0"	1'-1"	1'-2"	1'-2"	1'-10"	2'-2"	2'-7"	3'-4"	4'-0"	4'-2"	4'-11"	5'-8"	6'-5"	7'-2"
		20	1'-0"	1'-1"	1'-2"	1'-4"	2'-0"	2'-3"	2'-3"	4'-3"	5'-1"	5'-2"	6'-2"	7'-1"	7'-1"	9'-0"
		24	1'-0"	1'-1"	1'-2"	1'-7"	2'-9"	3'-4"	3'-11"	5'-1"	6'-1"	6'-3"	7'-4"	8'-6"	9'-8"	10'-10"

- Select a table row based on joist depth and the actual joist span rounded up to the nearest table span. Scan across the row to the column headed by the appropriate round hole diameter or rectangular hole side. Use the longest side of a rectangular hole. The table value is the closest that the centerline of the hole may be to the centerline of the nearest support.
- The entire web may be cut out. **DO NOT** cut the flanges. Holes apply to either single or multiple joists in repetitive member conditions.
- For multiple holes, the amount of uncut web between holes must equal at least twice the diameter (or longest side) of the largest hole.
- 1½" round knockouts in the web may be removed by using a short piece of metal pipe and hammer.
- Holes may be positioned vertically anywhere in the web. The joist may be set with the 1½" knockout holes turned either up or down.
- This table was designed to apply to the design conditions covered by tables elsewhere in this publication. Use the BC CALC® software to check other hole sizes or holes under other design conditions. It may be possible to exceed the limitations of this table by analyzing a specific application with the BC CALC® software.



# Reinforced Load Bearing Cantilever Tables

## AJS® Joists

Joist Depth [in]	Joist Series	Roof Total Load [psf]										
		35			45			55				
		Joist Spacing [in]										
Roof Truss Span [ft]	16	19.2	24	16	19.2	24	16	19.2	24			
AJS® 10	9 1/2"	24	0	0	1	0	0	X	0	X	X	
		26	0	0	1	0	1	X	1	X	X	
		28	0	0	X	0	1	X	1	X	X	
		30	0	0	X	0	X	X	X	X	X	
		32	0	0	X	1	X	X	X	X	X	
		34	0	1	X	1	X	X	X	X	X	
	7"	36	0	1	X	1	X	X	X	X	X	
		38	0	X	X	X	X	X	X	X	X	
		40	0	X	X	X	X	X	X	X	X	
		14"	24	0	0	0	0	0	0	0	0	X
			26	0	0	0	0	0	1	0	0	X
			28	0	0	0	0	0	0	1	0	X
30	0		0	0	0	0	0	1	0	X		
32	0		0	0	0	0	X	0	1	X		
34	0		0	1	0	1	X	0	X	X		
16"	36	0	0	1	0	1	X	1	X	X		
	38	0	0	1	0	1	X	1	X	X		
	40	0	0	X	0	1	1	X	X	X		
	16"	24	0	0	0	0	0	0	0	0	WS	
		26	0	0	0	0	0	WS	0	0	WS	
		28	0	0	0	0	0	WS	0	0	1	
30		0	0	0	0	0	WS	0	0	1		
32		0	0	0	0	0	WS	0	WS	X		
34		0	0	0	0	0	1	0	WS	X		
16"	36	0	0	W	0	0	1	0	1	X		
	38	0	0	W	0	0	1	0	1	X		
	40	0	0	W	0	0	1	0	1	X		
	16"	24	0	0	0	0	0	0	0	0	WS	
		26	0	0	0	0	0	WS	0	0	WS	
		28	0	0	0	0	0	WS	0	0	WS	
30		0	0	0	0	0	WS	0	0	WS		
32		0	0	0	0	0	WS	0	WS	1		
34		0	0	WS	0	0	WS	0	WS	1		
16"	36	0	0	WS	0	0	WS	0	WS	1		
	38	0	0	WS	0	0	WS	0	WS	1		
	40	0	0	WS	0	0	WS	0	WS	X		

Joist Depth [in]	Joist Series	Roof Total Load [psf]										
		35			45			55				
		Joist Spacing [in]										
Roof Truss Span [ft]	16	19.2	24	16	19.2	24	16	19.2	24			
AJS® 10	9 1/2"	24	0	0	1	0	0	2	0	1	X	
		26	0	0	1	0	1	X	1	2	X	
		28	0	0	1	0	1	X	1	X	X	
		30	0	0	2	0	1	X	1	X	X	
		32	0	0	2	1	1	X	2	X	X	
		34	0	1	X	1	2	X	1	X	X	
	11 7/8"	36	0	1	X	1	X	X	X	X	X	
		38	0	1	X	1	X	X	X	X	X	
		40	0	1	X	2	X	X	X	X	X	
		14"	24	0	0	0	0	0	0	0	0	1
			26	0	0	0	0	0	1	0	0	1
			28	0	0	0	0	0	1	0	1	X
30	0		0	0	0	0	1	0	1	X		
32	0		0	0	0	0	1	0	1	X		
34	0		0	1	0	0	2	0	1	X		
16"	36	0	0	1	0	1	X	1	2	X		
	38	0	0	1	0	1	X	1	2	X		
	40	0	0	1	0	1	X	1	X	X		
	14"	24	0	0	0	0	0	0	0	0	WS	
		26	0	0	0	0	0	WS	0	0	WS	
		28	0	0	0	0	0	WS	0	0	1	
30		0	0	0	0	0	WS	0	WS	1		
32		0	0	0	0	0	WS	0	WS	1		
34		0	0	WS	0	0	1	0	WS	X		
16"	36	0	0	WS	0	0	1	0	1	X		
	38	0	0	WS	0	W	1	0	1	X		
	40	0	0	WS	0	W	1	W	1	X		
	16"	24	0	0	0	0	0	0	0	0	WS	
		26	0	0	0	0	0	WS	0	0	WS	
		28	0	0	0	0	0	WS	0	0	WS	
30		0	0	0	0	0	WS	0	WS	WS		
32		0	0	0	0	0	WS	0	WS	1		
34		0	0	WS	0	0	WS	0	WS	1		
16"	36	0	0	WS	0	0	WS	0	WS	1		
	38	0	0	WS	0	WS	0	WS	1	1		
	40	0	0	WS	0	WS	1	WS	WS	X		

Joist Depth [in]	Joist Series	Roof Total Load [psf]										
		35			45			55				
		Joist Spacing [in]										
Roof Truss Span [ft]	16	19.2	24	16	19.2	24	16	19.2	24			
AJS® 20	9 1/2"	24	0	0	1	0	0	2	0	2	X	
		26	0	0	1	0	1	X	1	2	X	
		28	0	0	1	0	1	X	1	2	X	
		30	0	0	2	0	2	X	1	X	X	
		32	0	0	2	1	2	X	2	X	X	
		34	0	1	2	1	2	X	2	X	X	
	11 7/8"	36	0	1	2	1	2	X	2	X	X	
		38	0	1	2	1	2	X	2	X	X	
		40	0	1	2	1	2	X	2	X	X	
		14"	24	0	0	0	0	0	0	0	0	WS
			26	0	0	0	0	0	1	0	0	2
			28	0	0	0	0	0	1	0	1	X
30	0		0	0	0	0	1	0	1	X		
32	0		0	WS	0	0	2	0	1	X		
34	0		0	1	0	0	X	0	1	X		
16"	36	0	0	1	0	1	X	1	2	X		
	38	0	0	1	0	1	X	1	2	X		
	40	0	0	1	0	1	X	1	X	X		
	14"	24	0	0	0	0	0	0	0	0	WS	
		26	0	0	0	0	0	WS	0	0	WS	
		28	0	0	0	0	0	WS	0	0	1	
30		0	0	0	0	0	WS	0	WS	1		
32		0	0	0	0	0	WS	0	WS	1		
34		0	0	0	0	0	WS	0	WS	1		
16"	36	0	0	WS	0	WS	1	0	1	X		
	38	0	0	WS	0	WS	1	0	1	X		
	40	0	0	WS	0	WS	1	WS	1	X		
	16"	24	0	0	0	0	0	0	0	0	WS	
		26	0	0	0	0	0	WS	0	0	WS	
		28	0	0	0	0	0	WS	0	0	WS	
30		0	0	0	0	0	WS	0	WS	WS		
32		0	0	0	0	0	WS	0	WS	1		
34		0	0	WS	0	0	WS	0	WS	1		
16"	36	0	0	WS	0	WS	WS	0	WS	1		
	38	0	0	WS	0	WS	WS	0	WS	1		
	40	0	0	WS	0	WS	WS	WS	WS	1		
	40	0	0	WS	0	WS	1	WS	WS	X		

Joist Depth [in]	Joist Series	Roof Total Load [psf]										
		35			45			55				
		Joist Spacing [in]										
Roof Truss Span [ft]	16	19.2	24	16	19.2	24	16	19.2	24			
AJS® 190	9 1/2"	24	0	0	1	0	0	2	0	2	X	
		26	0	0	1	0	1	X	1	2	X	
		28	0	0	1	0	1	X	1	X	X	
		30	0	0	2	0	2	X	1	X	X	
		32	0	0	2	1	2	X	2	X	X	
		34	0	1	X	1	2	X	2	X	X	
	11 7/8"	36	0	1	X	1	X	X	X	X	X	
		38	0	1	X	2	X	X	X	X	X	
		40	0	2	X	2	X	X	X	X	X	
		14"	24	0	0	0	0	0	WS	0	0	1
			26	0	0	0	0	0	1	0	0	2
			28	0	0	0	0	0	1	0	1	X
30	0		0	0	0	0	1	0	1	X		
32	0		0	WS	0	0	2	0	1	X		
34	0		0	1	0	0	X	0	1	X		
16"	36	0	0	1	0	1	X	1	2	X		
	38	0	0	1	0	1	X	1	X	X		
	40	0	0	1	0	1	X	1	X	X		
	14"	24	0	0	0	0	0	0	0	0	WS	
		26	0	0	0	0	0	WS	0	0	WS	
		28	0	0	0	0	0	WS	0	WS	1	
30		0	0	0	0	0	WS	0	WS	1		
32		0	0	0	0	0	WS	0	WS	1		
34		0	0	WS	0	0	1	0	WS	X		
16"	36	0	0	WS	0	WS	1	0	1	X		
	38	0	0	WS	0	WS	1	WS	1	X		
	40	0	0	WS	0	WS	1	WS	1	X		
	16"	24	0	0	0	0	0	0	0	0	WS	
		26	0	0	0	0	0	WS	0	0	WS	
		28	0	0	0	0	0	WS	0	0	WS	
30		0	0	0	0	0	WS	0	WS	WS		
32		0	0	0	0	0	WS	0	WS	1		
34		0	0	WS	0	0	WS	0	WS	1		
16"	36	0	0	WS	0	WS	WS	0	WS	1		
	38	0	0	WS	0	WS	WS	WS	WS	1		
	40	0	0	WS	0	WS	1	WS	WS	X		

Joist Depth [in]	Joist Series	Roof Total Load [psf]										
		35			45			55				
		Joist Spacing [in]										
Roof Truss Span [ft]	16	19.2	24	16	19.2	24	16	19.2	24			
AJS® 25	9 1/2"	24	0	0	1	0	0	X	0	2	X	
		26	0	0	1	0	1	X	1	X	X	
		28	0	0	2	0	1	X	1	X	X	
		30	0	0	2	0	2	X	2	X	X	
		32	0	0	X	1	2	X	2	X	X	
		34	0	1	X	1	X	X	X	X	X	
	11 7/8"	36	0	1	X	1	X	X	X	X	X	
		38	0	2	X	2	X	X	X	X	X	
		40	0	2	X	2	X	X	X	X	X	
		14"	24	0	0	0	0	0	0	0	0	2
			26	0	0	0	0	0	1	0	0	2
			28	0	0	0	0	0	1	0	1	X
30	0		0	0	0	0	2	0	1	X		
32	0		0	0	0	0	2	0	1	X		
34	0		0	1	0	0	2	0	2	X		
16"	36	0	0	1	0	1	X	1	2	X		
	38	0	0	1	0	1	X	1	X	X		
	40	0	0	2	0	1	X	1	X	X		
	14"	24										

# Reinforced Load Bearing Cantilever Detail

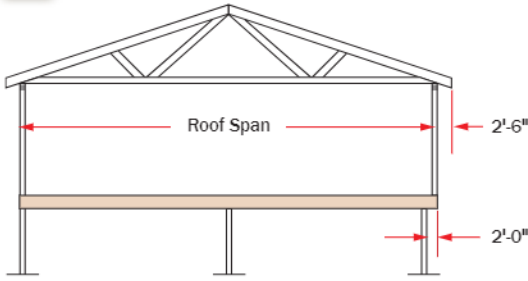

### PLYWOOD / OSB REINFORCEMENT (if Required per Table on page 3)

- 2'-0" Min. x 48" long plywood / OSB rated sheathing must match the full depth of the AJS® Joist. Nail to the AJS® Joist with 8d nails at 6" o.c. and nail with 4d nails into backer block. When reinforcing both sides, stagger nails to limit splitting. Install with horizontal face grain.
- These requirements assume a 100 PLF wall load and apply to AJS® Joists. Additional support may be required for other loadings. See BC CALC® software.
- Contact Boise Cascade EWP Engineering for reinforcement requirements on AJS® Joist depths greater than 16".

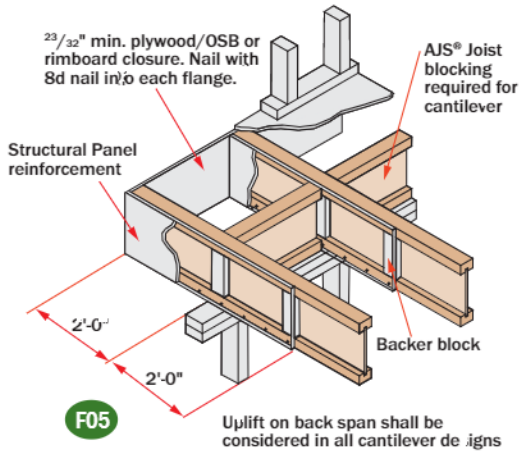

• The tables and details on pages 9 and 10 indicate the type of reinforcements, if any, that are required for load bearing cantilevers up to a maximum length of 2'-0". Cantilevers longer than 2'-0" cannot be reinforced. **Do not use longer cantilevers with lower loads than, be allowable without reinforcement. Always specify application with the BC CALC® software**

# Brick Ledge Load Bearing Cantilever

## F20A Brick Ledge With Blocking Panels

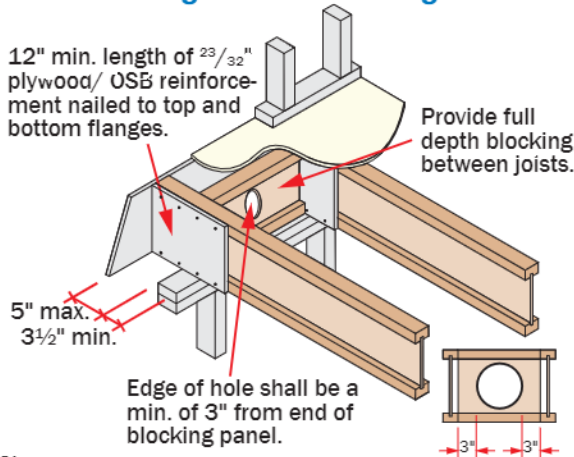

Notes:

1. Use 2<sup>3</sup>/<sub>32</sub>" min plywood/OSB rated sheathing. Install full depth of joist with face grain parallel to joist. Plywood reinforcement to bear fully on wall plate. Nail plywood to top and bottom joist flanges with 2 1/2" (8d) nails at 3" on center except 2 1/2" joists. Install nails at 2 1/2" on center.
2. Provide full depth blocking between joists.
3. Edge of hole shall be at a minimum of 3" from end of blocking panel.

## F20B Brick Ledge Without Blocking Panels

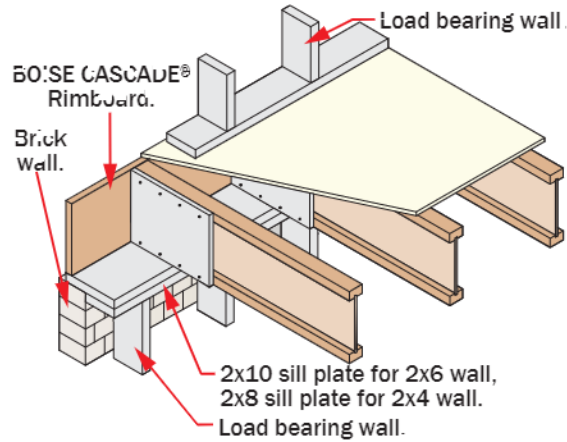

Notes:

1. Use 2<sup>3</sup>/<sub>32</sub>" min plywood/OSB rated sheathing. Install full depth of joist with face grain parallel to joist. Plywood reinforcement to bear fully on wall plate. Nail plywood to top and bottom joist flanges with 2 1/2" (8d) nails at 3" on center except 2 1/2" joists. Install nails at 2 1/2" on center.
2. See page 5 for joist and rimboard connection details.

Joist Depth (inches)	Roof Truss Span (ft)	Roof Live Load (psf)									
		20 psf			30 psf			50 psf			
		Joist Spacing o.c.									
		12"	16"	19.2"	12"	16"	19.2"	12"	16"	19.2"	
2 1/2"	24'	0	0	0	0	0	0	0	0	0	0
	26'	0	0	0	0	0	0	0	1	1	2
	28'	0	0	0	0	0	0	1	1	1	2
	30'	0	0	0	0	0	1	0	1	1	2
	32'	0	0	0	0	1	0	1	2	2	2
	34'	0	0	X	0	X	0	1	2	2	X
1 7/8"	24'	0	0	0	0	0	0	0	0	0	0
	26'	0	0	0	0	0	0	0	0	0	0
	28'	0	0	0	0	0	0	0	0	1	1
	30'	0	0	0	0	0	0	0	0	1	1
	32'	0	0	0	0	0	0	0	0	1	1
	34'	0	0	0	0	1	0	0	0	1	1
1 1/2"	24'	0	0	0	0	0	0	0	0	0	0
	26'	0	0	0	0	0	0	0	0	0	0
	28'	0	0	0	0	0	0	0	0	0	1
	30'	0	0	0	0	0	0	0	0	0	1
	32'	0	0	0	0	0	0	0	0	0	0
	34'	0	0	0	0	0	0	0	0	0	0

## Brick Ledge Reinforcement Table

### Table Design Assumptions

**Roof Loading:** 15 psf dead load plus a 100 PLF wall self-weight, in addition to roof live load shown. Maximum 2'-6" overhangs assumed on roof trusses.

**Floor Loading:** 40 psf live load plus 10 psf dead load, but spans not to exceed maximum floor spans shown on page 3.

### KEY TO TABLE:

- 0 = No Reinforcement Required
- 1 = Reinforcement Required One Side of Joist
- 2 = Reinforcement Required Both Sides of Joist
- x = Use Deeper Joists or Closer Spacing



AJS® Joists are intended only for applications that provide permanent protection from the weather.

Fasten the 2x8 minimum to the AJS® Joist by nailing through the backer block and joist web with 2 rows of 10d nails at 6" on center. Clinch all nails.

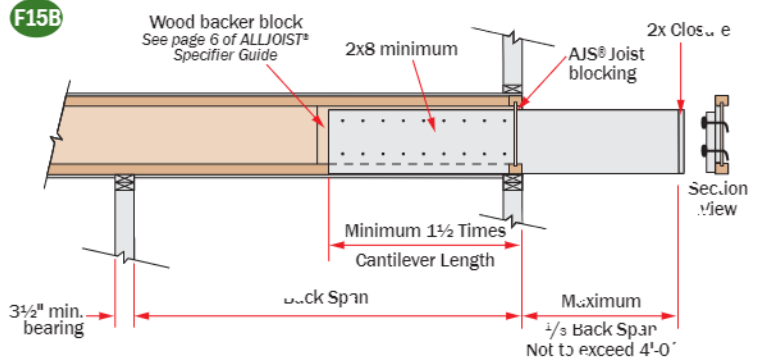
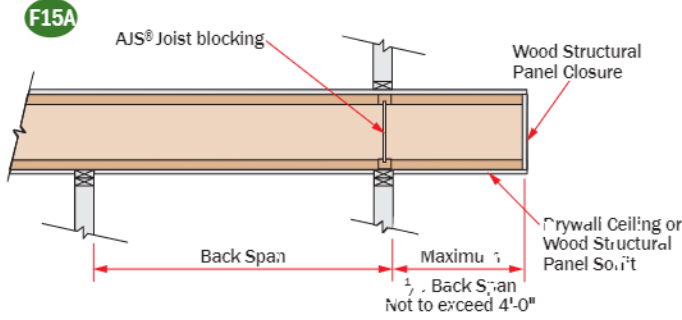

- These details apply to cantilevers with uniform loads only.
- It may be possible to exceed the limitations of these details by analyzing a specific application with the BC CALC® software.

## Large Rectangular Holes in AJS® Joists

Hole size table based on maximum uniform load of 40 psf live load and 15 psf dead load, at maximum spacing of 24" on-center.

### Single Span Joist

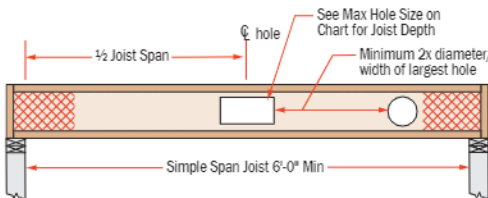

**Notes:**

Additional holes may be cut in the web provided they meet the specifications as shown in the hole distance chart shown above or as allowed using BC CALC® sizing software.

Joist Depth	Maximum Hole Size	
	Simple Span	Multiple Span
9 1/2"	6" x 12"	6" x 7"
11 7/8"	3" x 13"	8" x 8"
14"	9" x 16"	8" x 13"
	10" x 14"	9" x 11"
16"	11" x 16"	10" x 14"
	12" x 15"	11" x 12"

### Multiple Span Joist

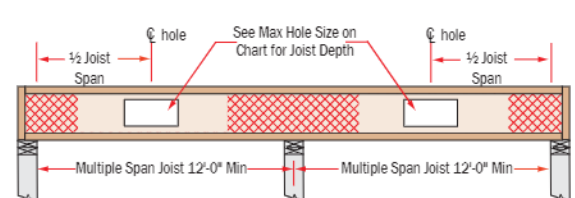

Larger holes may be possible for either Single or Multiple span joists; use BC CALC® sizing software for specific analysis.

## AJS® Joists — Connection Details

### Connection on Steel Beam

F15D

Attachment of nailer per design professional of record.

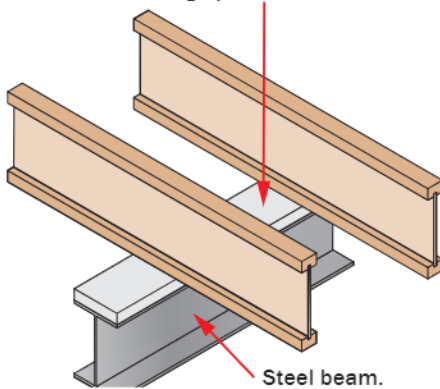

### Connection with Hanger on Steel Beam

F15E

Attachment of nailer per design professional of record.

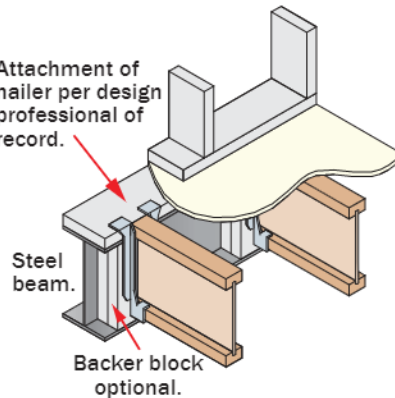

### Hanger Connections to AJS Headers

F16D

- Backer blocks shall be at least 12" long per hanger.
- Nails shall be clinched when possible.
- Verify capacity and fastening requirements of hangers and connectors.

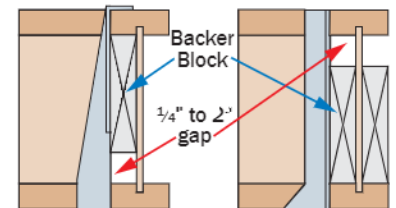

**"Top Mount"** Backer block shall be tight to bottom of top flange with 1/4" to 2" gap at top of bottom flange.

**"Face Mount"** Backer block shall be tight to bottom of top flange with 1/4" to 2" gap at top of bottom flange.

# BOISE CASCADE® Rimboard

## BOISE CASCADE® Rimboard Product Profiles

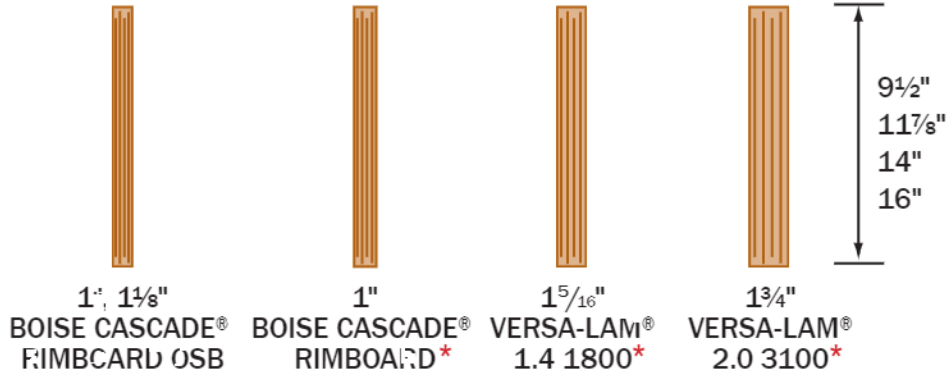

\*18 – 24 inch deep rimboard are special order product, contact local supplier or Boise Cascade representative for product availability.

**F07** **Perpendicular**  
See chart for vertical load capacity.

Min. 8d nails at 6" o.c. per IRC. Connection per design professional of record's specification for shear transfer.

**F07A** **Parallel**  
See chart for vertical load capacity.

Min. 8d nails at 6" o.c. per IRC. Connection per design professional of record's specification for shear transfer.

**F56**

1/2" dia through bolts (ASTM A307 Grades A&B, SAE J429 Grades 1 or 2, or higher) with washers and nuts or 1/2" dia lag screws (full penetration) 350 lb capacity for 1 3/8" & thicker rim, 300 lb capacity for 1" rim, per fastener.

Treated Ledger - Use only fasteners that are approved for use with corresponding wood treatment.

Design of moisture control by others (only structural components shown above)

For information regarding connection of exterior deck to interior floor systems per the 2009 IRC, section 502.2.2.3, contact Boise Cascade EWP Engineering.

## BOISE CASCADE® Rimboard Properties

Product	Vertical Load Capacity						Maximum Floor Diaphragm Lateral Capacity [lb/ft]	Specific Gravity for Lateral Nail Design	Allowable Design Values			
	Uniform [plf]			Point [lb]					Flexural Stress [lb/in <sup>2</sup> ]	Modulus of Elasticity [lb/in <sup>2</sup> ]	Horizontal Shear [lb/in <sup>2</sup> ]	Compression Perpendicular to Grain [lb/in <sup>2</sup> ]
	16" Depth & Less	18" & 20" Depth & Less	22" & 24" Depth & Less	16" Depth & Less	18" & 20" Depth & Less	22" & 24" Depth & Less						
1" BOISE CASCADE® RIMBOARD (1) & 1" BOISE CASCADE® RIMBOARD OSB (2)	3300	1650	1650	3500	3500	3300	180	0.5	Limited span capabilities, see note 2			
1 1/8" BOISE CASCADE® RIMBOARD OSB (2)	4400	3000	3000	3500	3500	3500	180	0.5	Limited span capabilities, see note 2			
1 5/16" VERSA-LAM® 1.4 1800 (1)	6000	5450	—	4450	4450	—	Permitted per building code for all nominal 2" thick framing blocked and unblocked diaphragms (4" nail spacing & greater)	0.5	1800	1,400,000	225	525
1 3/4" VERSA-LAM® 2.0 3100 (1)	5700	4300	—	4300	3900	—	Permitted per building code for all nominal 2" thick framing blocked and unblocked diaphragms (4" nail spacing & greater)	0.5	2800	2,000,000	285	750

Product	Closest Allowable Nail Spacing - Narrow Face [in]					
	8d Box	8d Common	10d & 12d Box	16d Box	10d, 12d Common & 16d Sinker	16d Common
1" BOISE CASCADE® RIMBOARD (2)	3	3	-	-	-	-
1" or 1 1/8" BOISE CASCADE® RIMBOARD OSB (2)	3	3	See note 2 for nailing information			
1 5/16" VERSA-LAM® 1.4 1800 (1)	3	3	3	3	4	6
1 3/4" VERSA-LAM® 2.0 3100 (1)	2	3	3	3	4	6

**Notes**

1. Per ICC ESR-1040.
2. See *Performance Rated Rim Boards, APA EWS #W345K* for further product information.
3. Not all products and depths may be available, check with Boise Cascade representative for product availability.



AJS® Joist Series	Depth [inches]	Weight [plf]	Moment M <sub>r</sub> [ft-lbs]	EI x 10 <sup>6</sup> [lb-in <sup>2</sup> ]	K x 10 <sup>6</sup> [lbs]	Shear V <sub>r</sub> [lbs]	End Reaction [lbs]				Intermediate Reaction [lbs]			
							1½" Bearing		3½" Bearing		3½" Bearing		5¼" Bearing	
							No WS <sup>(1)</sup>	WS <sup>(2)</sup>	No WS <sup>(1)</sup>	WS <sup>(2)</sup>	No WS <sup>(1)</sup>	WS <sup>(2)</sup>	No WS <sup>(1)</sup>	WS <sup>(2)</sup>
AJS® 140	9½	2.2	2450	182	5.2	1160	950	1240	1175	1480	2350	2450	2350	2450
	11⅞	2.5	3175	310	6.6	1490	955	1335	1215	1595	2390	2800	2390	2800
	14	2.8	3825	457	7.8	1790	960	1420	1250	1700	2430	3130	2430	3130
	16	3.1	4435	623	9.0	2065	970	1500	1285	1800	2465	3435	2465	3435
AJS® 150	9½	2.2	2820	194	5.2	1160	950	1240	1175	1480	2350	2450	2350	2450
	11⅞	2.5	3650	331	6.6	1490	955	1335	1215	1595	2390	2800	2390	2800
	14	2.8	4390	487	7.8	1790	960	1420	1250	1700	2430	3130	2430	3130
	16	3.1	5090	664	9.0	2065	970	1500	1285	1800	2465	3435	2465	3435
AJS® 20	9½	2.5	3395	232	5.2	1160	950	1240	1175	1480	2350	2450	2350	2450
	11⅞	2.8	4400	394	6.6	1490	955	1335	1215	1595	2390	2800	2390	2800
	14	3.0	5295	578	7.8	1790	960	1420	1250	1700	2430	3130	2430	3130
	16	3.3	6140	786	9.0	2065	970	1500	1285	1800	2465	3435	2465	3435
AJS® 190	9½	2.5	3895	244	5.2	1160	950	1240	1175	1480	2350	2450	2350	2450
	11⅞	2.8	5045	414	6.6	1490	955	1335	1215	1595	2390	2800	2390	2800
	14	3.0	6070	608	7.8	1790	960	1420	1250	1700	2430	3130	2430	3130
	16	3.3	7040	827	9.0	2065	970	1500	1285	1800	2465	3435	2465	3435
AJS® 25	9½	3.1	5370	322	5.3	1160	950	1240	1175	1480	2600	2850	2600	2850
	11⅞	3.4	6960	545	6.7	1490	955	1335	1215	1595	2690	3190	2690	3190
	14	3.7	8380	798	7.9	1790	960	1420	1250	1700	2770	3500	2770	3500
	16	3.9	9720	1082	9.1	2065	970	1500	1285	1800	2850	3800	2850	3800

**NOTES:**

- (1) No web stiffeners required.
- (2) Web stiffeners required.
- (3) Not applicable, web stiffeners required.
- Moment, shear and reaction values based upon a load duration of 100% and may be adjusted for other load durations.
- Design values listed are applicable for Allowable Stress Design (ASD).
- No additional repetitive member increase allowed.

$$\Delta = \frac{5wL^4}{384EI} + \frac{wL^2}{K}$$

$\Delta$  = deflection [in]  
 $w$  = uniform load [lb/in]  
 $L$  = clear span [in]  
 $EI$  = bending stiffness [lb-in<sup>2</sup>]  
 $K$  = end deformation coefficient [lb]

**BUILDING CODE EVALUATION REPORT**

- ICC ESR 1144 (IBC, IRC)

## VERSA-LAM® Design Values

Grade	Width [in]	Depth [in]	Weight [lb/ft]	Allowable Shear [lb]	Allowable Moment [ft-lb]	Moment of Inertia [in <sup>4</sup> ]	Grade	Width [in]	Depth [in]	Weight [lb/ft]	Allowable Shear [lb]	Allowable Moment [ft-lb]	Moment of Inertia [in <sup>4</sup> ]	
VERSA-STUD® 1.7 2650	1½	3½	1.5	998	776	5.4	VERSA-LAM® 2.0 3100	5¼	5¼	8.0	5237	6830	63.3	
		5½	2.4	1538	1821	20.8			5½	8.4	5486	7457	72.8	
		7¼	3.2	2066	3069	47.6			7¼	11.0	7232	12566	166.7	
VERSA-LAM® 2.0 3100	1¾	3½	1.8	1164	1058	8.3			9¼	14.1	9227	19908	346.3	
		5½	2.8	1829	2486	24.3			9½	14.5	9476	20937	375.1	
		7¼	3.7	2411	4189	55.6			11¼	17.1	11222	28814	622.9	
		9¼	4.7	3076	6636	115.4			11⅞	18.1	11845	31913	732.6	
		9½	4.8	3159	6979	125.0			14	21.3	13965	43552	1200.5	
		11¼	5.7	3741	9605	207.6			16	24.4	15960	56046	1792.0	
		11⅞	6.0	3948	10638	244.2			18	27.4	17955	70011	2551.5	
		14	7.1	4655	14517	400.2			20	30.4	19950	85428	3500.0	
		16	8.1	5320	18682	597.3			24	36.5	23940	120549	6048.0	
		18	9.1	5985	23337	850.5			7	9¼	16.6	12303	26544	461.7
		24	12.2	7980	40183	2012.0				9½	17.1	12635	27916	500.1
		5½	5.6	3658	4971	48.5				11¼	20.2	14963	38419	830.6
7¼	7.4	4821	8377	111.1	11⅞	21.4	15794	42550		976.8				
9¼	9.4	6151	13272	230.8	14	25.2	18620	58069		1600.7				
9½	9.5	6318	13958	250.1	16	28.8	21280	74728		2389.3				
11¼	11.4	7481	19210	415.3	18	32.4	23940	93348		3402.0				
11⅞	12.1	7897	21275	488.4	20	36.0	26600	113904		4666.7				
14	14.2	9310	29035	800.3	24	43.2	31920	160732	8064.0					
16	16.2	10640	37364	1194.7										
18	18.3	11970	46674	1701.0										
20	20.3	13300	56952	2333.3										

Design Property	Grade	Modulus of Elasticity	Bending	Horizontal Shear	Tension Parallel to Grain	Compression Parallel to Grain	Compression Perpendicular to Grain	Equivalent Specific Gravity for Fastener Design
		$E(x 10^3 \text{ psi})^{(1)}$	$F_b \text{ (psi)}^{(2)(3)}$	$F_v \text{ (psi)}^{(2)(4)}$	$F_t \text{ (psi)}^{(2)(5)}$	$F_c \parallel \text{ (psi)}^{(2)}$	$F_c \perp \text{ (psi)}^{(1)(6)}$	(SG)
VERSA-LAM® Beams	2.0 3100	2.0	3100	285	2150	3000	750	0.5
VERSA-LAM® Studs	1.7 2650	1.7	2650	285	1650	3000	750	0.5
VERSA-LAM® Columns	1.8 2750	1.8	2750	285	1825	3000	750	0.5

1. This value cannot be adjusted for load duration.
  2. This value is based upon a load duration of 100% and may be adjusted for other load durations.
  3. Fiber stress bending value shall be multiplied by the depth factor,  $(12/d)^{10}$  where d = member depth [in].
  4. Stress applied perpendicular to the gluelines.
  5. Tension value shall be multiplied by a length factor,  $(4/L)^{1/3}$  where L = member length [ft]. Use L = 4 for members less than four feet long.
  6. Stress applied parallel to the gluelines.
- \* Design properties are limited to dry conditions of use where the maximum moisture content of the material will not exceed 16%.

## Multiple Member Connectors

### Side-Loaded Applications

Number of Members	Maximum Uniform Side Load [plf]							
	Nailed		1/2" Dia. Through Bolt <sup>(1)</sup>			5/8" Dia. Through Bolt <sup>(1)</sup>		
	2 rows 16d Sinks @ 12" o.c.	3 rows 16d Sinks @ 12" o.c.	2 rows @ 24" o.c. staggered	2 rows @ 12" o.c. staggered	2 rows @ 6" o.c. staggered	2 rows @ 24" o.c. staggered	2 rows @ 12" o.c. staggered	2 rows @ 6" o.c. staggered
<b>1 3/4" VERSA-LAM® (Depths of 1" and less)</b>								
2	470	705	505	1010	2020	560	1120	2245
3 <sup>(2)</sup>	350	525	375	755	1515	420	840	1685
4 <sup>(2)</sup>	use bolt schedule		335	670	1345	370	745	1495
<b>3 1/2" VERSA-LAM®</b>								
2 <sup>(2)</sup>	use bolt schedule		855	1715	N/A	1125	2250	N/A
<b>1 3/4" VERSA-LAM® (Depths of 2 1/4")</b>								
Number of Members	Nailed		1/2" Dia. Through Bolt <sup>(1)</sup>			5/8" Dia. Through Bolt <sup>(1)</sup>		
	3 rows 16d Sinks @ 12" o.c.	4 rows 16d Sinks @ 12" o.c.	3 rows @ 24" o.c. staggered	3 rows @ 18" o.c. staggered	3 rows @ 12" o.c. staggered	3 rows @ 24" o.c. staggered	3 rows @ 18" o.c. staggered	3 rows @ 12" o.c. staggered
	2	3	4	3	2	3	2	3

1. Design values apply to common bolts that conform to ANSI/ACME standard B18.21-1981 (ASME A307 Grades 1 & B, SAE J429 Grades 1 or 2, or higher). A washer not less than a standard cut washer shall be between the wood and the bolt head and between the wood and the nut. The distance from the edge of the beam to the bolt holes must be at least 2" for 1/2" bolts and 2 1/2" for 5/8" bolts. Bolt holes shall be the same diameter as the bolt.
2. The nail schedules shown apply to both sides of a 3-member beam.
3. 7" wide beams must be top-loaded or loaded from both sides (lesser side shall be no less than 25% of opposite side).

### Designing Connections for Multiple VERSA-LAM® Members

When using multiple ply VERSA-LAM® beams to create a wider member, the connection of the plies is as critical as determining the beam size. When side loaded beams are not connected properly, the inside plies do not support their share of the load and thus the load-carrying capacity of the full member decreases significantly. The following is an example of how to size and connect a multiple-ply VERSA-LAM® floor beam.

Give: Beam shown below is supporting essential floor load (40 psf live load, 10 psf dead load) and is spanning 16'-0". Beam depth is limited to 14".

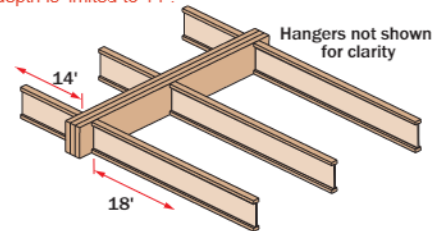

Find: A multiple 1 3/4" ply VERSA-LAM that is adequate to support the design loads and the member's proper connection schedule.

1. Calculate the tributary width that beam is supporting:  
 $14' / 2 + 18' / 2 = 16'$
2. Use PLF tables on pages 30-32 of ASG or BC CALC® to size beam.  
A Triple VERSA-LAM® 2.0 3100 1 3/4" x 14" is found to adequately support the design loads
3. Calculate the maximum plf load from one side (the right side in this case).  
Max. Side Load =  $(18' / 2) \times (40 + 10 \text{ psi}) = 450 \text{ plf}$
4. Go to the Multiple Member Connection Table, Side-Loaded Applications, 1 3/4" VERSA-LAM®, 3 members
5. The proper connection schedule must have a capacity greater than the max. side load:  
Nailed: 3 rows 16d sinks @ 12" o.c.  
525 plf is greater than 450 plf **OK**  
Bolts: 1 1/2" diameter 2 rows @ 12" staggered:  
755 plf is greater than 450 plf **OK**

### Top-Loaded Applications

For top-loaded beams and beams with side loads with less than those shown:

Ply	Depth	Nailing	Maximum Uniform Load From One Side
(2) 1 3/4" plies	Depths 1 1/2" & less	2 rows 16d box/sinker nails @ 12" o.c.	450 plf
	Depths 1 1/2" - 18"	3 rows 16d box/sinker nails @ 12" o.c.	600 plf
	Depth = 24"	4 rows 16d box/sinker nails @ 12" o.c.	800 plf
(3) 1 3/4" plies	Depths 1 1/2" & less	2 rows 16d box/sinker nails @ 12" o.c.	300 plf
	Depth = 14" - 18"	3 rows 16d box/sinker nails @ 12" o.c.	450 plf
	Depth = 24"	4 rows 16d box/sinker nails @ 12" o.c.	600 plf
(4) 1 3/4" plies	Depths 1 1/2" & less	2 rows 1/2" bolts @ 24" o.c. staggered	335 plf
	Depth = 24"	3 rows 1/2" bolts @ 24" o.c. staggered every 8"	505 plf
(2) 3 1/2" plies	Depths 18" & less	2 rows 1/2" bolts @ 24" o.c. staggered	855 plf
	Depth 20" - 24"	3 rows 1/2" bolts @ 24" o.c. staggered every 8"	1285 plf

1. Beams wider than 7" must be designed by the engineer of record.
2. All values in these tables may be increased by 25% for snow-load roofs and by 25% for non-snow-load roofs where the building code allows.
3. Use allowable load tables or BC CALC® software to size beams. An equivalent specific gravity of 0.5 may be used when designing specific connections with VERSA-LAM®.
4. Connection values are based upon the 20.0 NUS.
5. Fastener installation, Imp. on Strong-Tie SDS, and USP WS. crews may also be used to connect multiple members. VERSA-LAM® beam is not a Bolt-Cascade EWP. Eng. info. for further information.



## VERSA-LAM® Beam Details

### VERSA-LAM® Installation Notes

- Minimum of 1/2" air space between beam and wall pocket or adequate bearing must be provided between beam and concrete/masonry.
- Adequate bearing shall be provided. If not shown on plans, please refer to load tables in your region's Specifier Guide.
- VERSA-LAM® beams are intended for interior applications only and should be kept as dry as possible during construction.
- Continuous lateral support of top of beam shall be provided (side or top bearing framing).

## Closest Allowable Nail Spacing

### VERSA-LAM® & VERSA-RIM® Products

Nail Size	Nailing Parallel to Glue Lines (Narrow Face) <sup>(1)</sup>						Nailing Perpendicular to Glue Lines (Wide Face)	
	VERSA-LAM® 1.4 1800 Rimboard 1 5/16"		VERSA-LAM® 1 3/4"		VERSA-LAM® 3 1/2" & Wider		All Products	
	O.C. [inches]	End [inches]	O.C. [inches]	End [inches]	O.C. [inches]	End [inches]	O.C. [inches]	End [inches]
8d Box	3	1 1/2	2	1	2	1/2	2	1/2
8d Common	3	2	3	2	2	1	2	1
10d & 12d Box	3	2	3	2	2	1	2	1
16d Box	3	2	3	2	2	1	2	1
10d & 12d Common	4	3	4	3	2	2	2	2
16d Sinker	4	3	4	3	2	2	2	2
16d Common	6	4	6	3	2	2	2	2

- Offset and stagger nail rows from floor sheathing and wall sole plate.
- Simpson Strong-Tie A35 and LP14 connectors may be attached to the side VERSA-LAM®/VERSA-RIM®. Use nails as specified by Simpson Strong-Tie.

Nailing Parallel to Glue Lines (Narrow Face)

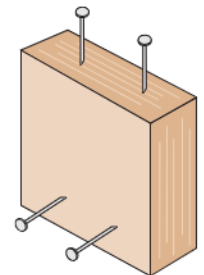

Nailing Perpendicular to Glue Lines (Wide Face)

### Nailing Notes

- For 3/4" thickness and greater, 2 rows of nails (such as with a metal strap) are allowed (use 1/2" minimum offset between rows and stagger nails).

## Allowable Holes in VERSA-LAM® Beams

### Notes

1. Square and rectangular holes are not permitted.
2. Round holes may be drilled or cut with a hole saw anywhere within the shaded area of the beam.
3. The horizontal distance between adjacent holes must be at least two times the size of the larger hole.
4. Do not drill more than three access holes in any four foot long section of beam.
5. The maximum round hole diameter permitted is:

Beam Depth	Max. Hole Diameter
5 1/2"	3/4"
7 1/4"	1"
9 1/4" and greater	2"

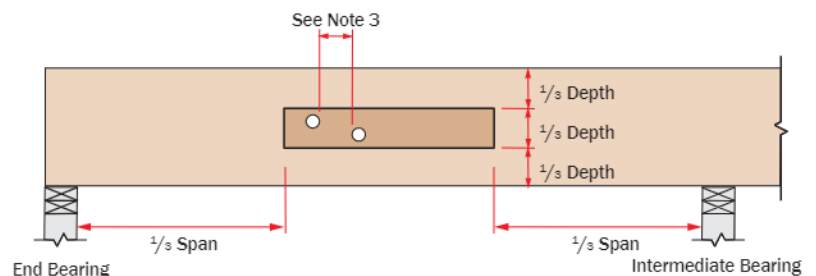

6. These limitations apply to holes drilled for plumbing or wiring access only. The size and location of holes drilled for fasteners are governed by the provisions of the *National Design Specification® for Wood Construction*.
7. Beams deflect under load. Size holes to provide clearance where required.
8. This hole chart is valid for beams supporting uniform load only. For beams supporting concentrated loads or for beams with larger holes, contact Boise Cascade EWP Engineering.

# Handling and Storage of Engineered Wood Products

## Site Storage

Protect **AJS® Joists** and **VERSA-LAM®** from the weather.

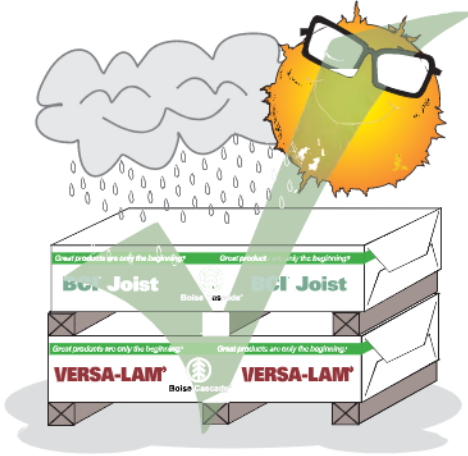

Keep at least 3½" off the ground, more in wetter areas. Align stickers one above another and space a maximum of 15 feet apart.

Leave **AJS® Joists** banded together until ready to install.

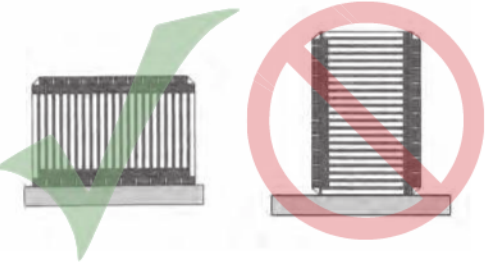

## Site Handling

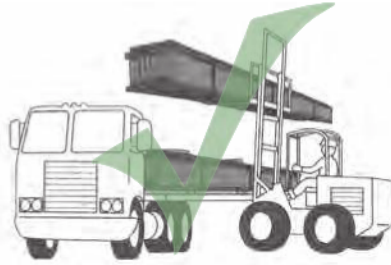

Unload from truck carefully using appropriate equipment.



DO NOT lift **AJS® Joists** by top flange.



Do not drop **AJS® Joists** from height.



Avoid lifting **AJS® Joists** horizontally.

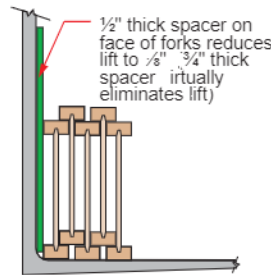
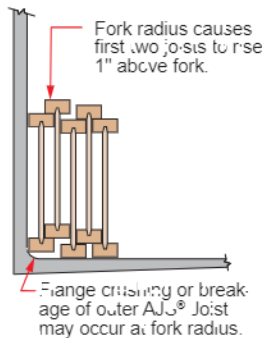

This damage can be prevented by making sure that all joists are sitting on the flat portion of the forks. This can be accomplished by making sure that the forks are not fully extended into the unit. A spacer may be required on the front face of the forks in order to assure that the joists sit on the flat portion of the forks and do not come in contact with the radius area of the forks. This procedure will equalize the pressure on the flanges of all joists.

**AJS® Fork Radius Crushing**

**BCI® Joists, VERSA-LAM® and ALLJOIST®** must be stored, installed and used in accordance with the Boise Cascade EWP Installation Guide, building codes, and to the extent not inconsistent with the Boise Cascade EWP Installation Guide, usual and customary building practices and standards. **VERSA-LAM®, ALLJOIST®, and BCI® Joists** must be wrapped, covered, and stored off the ground on stickers at all times prior to installation. **VERSA-LAM®, ALLJOIST® and BCI® Joists** are intended only for applications that assure no exposure to weather or the elements and an environment that is free from moisture from any source, or any pest, organism or substance which degrades or damages wood or glue bonds. Failure to correctly store, use or install **VERSA-LAM®, ALLJOIST®, and BCI® Joist** in accordance with the Boise Cascade EWP Installation Guide will void the limited warranty.

BOISE CASCADE TREE-IN-A-CIRCLE, BCI, BC CALC, BC CC, UWIN, BC FRAMER, BC RIM BOARD, BOISE CLICALM, SIMPLE FRAMING SYSTEM, VERSA-LAM, VERSA-RIM, VERSA-STRAND, and VERSA-STUD are trademarks of Boise Cascade Company or its affiliates.



The information in this document pertains to use in the **UNITED STATES ONLY, Allowable Stress Design**. Refer to the **ALLJOIST®** Specialist Guide Canada for use in Canada, Limit States Design.

Your Dealer is:

If no dealer is listed, call 1-800-232-0788

For information about **Boise Cascade Engineered Wood Products**, including sales terms and conditions, warranties and disclaimers,

visit our website at [www.BCewp.com](http://www.BCewp.com)



**Boise Cascade**  
Engineered Wood Products

**Great products are only the beginning.®**

Copyright © Boise Cascade Wood Products, L.L.C. 2013  
AIG US 68/29/2013 r 11/20/2018