



Boise Cascade
Engineered Wood Products

ALLJOIST® COMMERCIAL GUIDE

for ALLJOIST® products manufactured in St. Jacques, New Brunswick Canada
& VERSA-LAM® products manufactured in Alexandria [Lena], Louisiana



The SIMPLE FRAMING SYSTEM® Makes Designing Homes Easier

Architects, engineers, and designers trust Boise Cascade's engineered wood products to provide a better system for framing floors and roofs.

Boise Cascade Engineered Wood Products for Light Commercial Applications

Boise Cascade Engineered Wood Products are readily available through experienced distributors and retailers who provide valuable assistance in selecting and specifying the most economical joist and beam system. By specifying the products shown in the guide, time delays associated with so-called custom products from other manufacturers are minimized. While those products may be structurally adequate, they are only available on a "build to order" basis. That means your clients have automatically just added a minimum of 2-3 weeks to their production cycle: an eternity in today's tight construction schedules. Add that same amount of time for a single mis-cut joist and you can certainly see how quickly a well-intended specification can turn into a logistical nightmare.

This design guide is intended to provide information for the preliminary sizing of Boise Cascade Engineered Wood Products. While the products and applications shown in this guide are similar to our residential applications guide, the building code provisions and design requirements of the light commercial projects are significantly different. Concentrated floor load provisions, partition loads, wind and seismic provisions and fire protection systems are all examples of these differences. This guide helps identify these issues and provides corresponding product application details. Professional guidelines in most areas require the project's design professional of record to be responsible for the overall design

of light commercial structures. This guide is intended to assist the design professional in specifying engineered wood products in dry-use condition of such structures.

ALLJOIST® and BCI® joists and VERSA-LAM® beams are manufactured per corresponding International Code Council building code evaluation reports. Testing and quality control is certified by an independent inspection agency. Boise Cascade Engineered Wood Products are warranted for the life of the structure (see back cover of this guide). For the location of the nearest Boise Cascade representative or supplier of Boise Cascade Engineered Wood Products, please call 800-232-0788.

For complete information on fire resistance detailing and design with the entire Boise Cascade EWP product line, please refer to the US Fire Design & Installation Guide, located at www.bcewp.com.

Product Profiles, ALLJOIST® Product Architectural Specifications	3	VERSA-LAM® Details, Multiple Member Connectors	40
40 PSF - 250 PSF Live/Concentrated Load Span Tables	4 - 13	VERSA-LAM® Allowable Floor Joist Spans	41
AJS® Floor Framing Details	14 - 17	VERSA-LAM® Floor Load Tables (100% Load Duration)	42
AJS® Multiple Ply AJS® Members / Concentrated Load Connections	18	VERSA-LAM® Snow Roof Load Tables (115% Load Duration)	43
AJS® Multiple Ply AJS® Members / Header Blocking at Side Loaded	19	VERSA-LAM® Non-Snow Roof Load Tables (125% Load Duration)	44
AJS® Joist Hole Location & Sizing / Large Rectangular Holes	20	VERSA-LAM® Closest Allowable Nail Spacing	45
AJS® Cantilever Details, Web Stiffener Requirements	21	VERSA-LAM® Design values	45
AJS® Floor Load Tables	22 - 24	VERSA-LAM® Columns, VERSA-STUD®	43
AJS® Roof Framing Details	25 - 26	Computer Software	47
AJS® Roof Span Tables	27 - 32	Framing Connectors	48 - 49
AJS® Roof Load Tables	33 - 36		50
AJS® Design Properties, AJS® Allowable Nail Spacing	37		51
Boise Cascade Rimboard Products	38		51
VERSA-LAM® Products, Specifications, Allowable Holes	39	Lifetime Guarantee	Back Cover

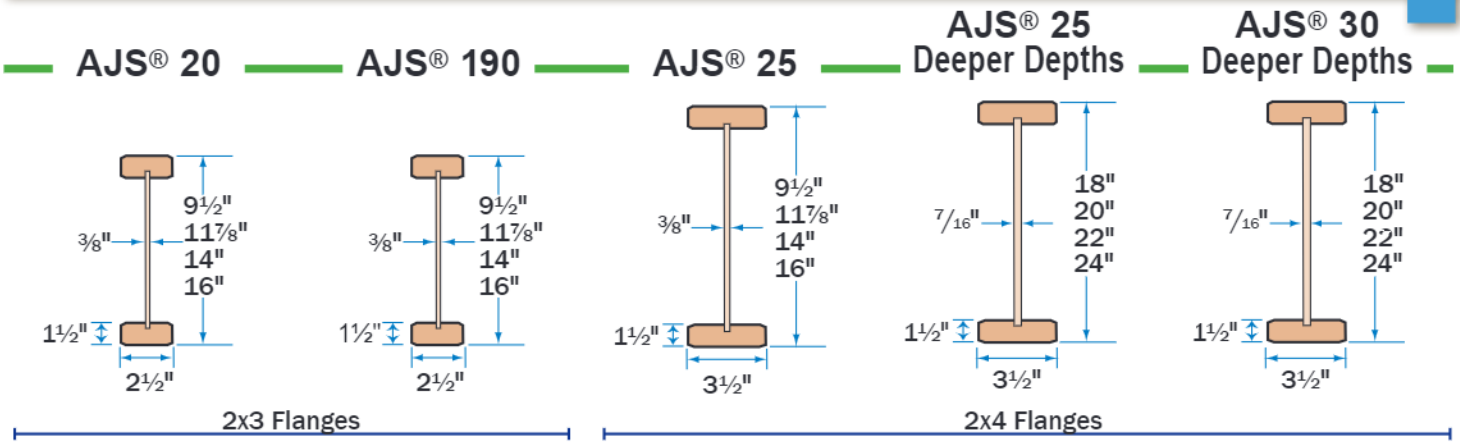

ALLJOIST® Product Architectural Specifications

EVALUATION SUBJECT: AJS® Series Prefabricated Wood I-Joists

1.0 Evaluation Scope:

Compliance with the following codes:

- *International Building Code® (IBC)*
- *International Residential Code® (IRC)*

Properties Evaluated: Structural.

2.0 Uses. The AJS® Joists are prefabricated wood joists used as floor joists, roof rafters and blocking panels, to support code required loads. Prefabricated wood I-joists described in this report comply with Section 2303.1.2 of the IRC and Section R502.1.4 of the IRC, for allowable stress design.

3.0 Description.

3.1 General: The AJS® Series prefabricated wood I-joists have solid-sawn lumber or composite lumber flanges and oriented strand board (OSB) webs. The top and bottom flanges are parallel, creating constant depth joists. The web-to-web joints of the I-joists are square butt joints and conform to the specifications in the approved quality control manuals. The web-to-flange connection is a proprietary grooved connection also conforming to the approved quality control manuals. The I-joists are available in various lengths and depths. See ESR-1144 Table 1 for full description of the AJS® I-Joists.

3.2 Material Specifications:

3.2.1 Flanges: The flanges of the I-joists are sawn lumber or composite lumber conforming to the specifications in the approved quality control manuals. The lumber flanges are 1 1/2 inch x either 2 1/2 inch or 3 1/2 inch, 3" mm x either 64 mm or

80 mm, spruce-pine-fir (SPF) and are used interchangeably with any of the sawn lumber flanges of the same dimensions. The sawn lumber flange material, grade, width and depth are noted in ESR-1144, Table 1.

3.2.2 Web: Web material for the I-Joists is 3/8-inch thick (10mm) or 1/16-inch-thick (1mm) OSB conforming to Exposure 1 requirements of DOCP-2 with further requirements set forth in the approved quality control manuals and manufacturing standard.

3.2.3 Adhesive: Adhesives used in the fabrication of the I-joists are exterior-type, heat durable adhesives complying with ASTM D 2559 and ASTM D 3055, and are specified in the quality control manuals and the manufacturing standards.

4.0 Design and Installation: Design of the prefabricated wood I-joists described in this report shall be in accordance with the applicable code. Additionally, the design and installation of the prefabricated wood I-joists shall comply with Sections 4.1 through 4.12 listed in ESR-1144 which include 4.1 Allowable Structural Capacity, 4.2 Fasteners, 4.3 Web Stiffeners, 4.4 Lateral Support, 4.5 Holes in I-Joist Web, 4.6 Duration of Load, 4.7 In-Service Moisture Conditions, 4.8 Repetitive-Member Use, 4.9 Member Spans, 4.10 Deflection, 4.11 Blocking Panels, & 4.12 Cantilevered Joists, and the manufacturer's installation instructions.

5.0 Conditions of Use: The AJS® Series I-joists described in this report comply with, or are suitable alternatives to what is specified in, those codes listed under ESR-1144, Section 1.0 Evaluation Scope of these specifications, subject to the following conditions:

- 5.1 AJS® joists must be installed in accordance with this report and the manufacturer's installation instructions.

5.2 Drawings and design details verifying compliance with this report must be submitted to the code official when requested. The drawings and calculations must be prepared by a registered design professional where required by the statutes of the jurisdiction in which the project is to be constructed.

5.3 Flanges of the I-joist may not be cut or notched, unless an engineered design prepared by a registered design professional is submitted to the code official for approval.

5.4 The AJS® joists are manufactured by Boise Cascade Wood Products, L.L.C. at their plant in St. Jacques, New Brunswick, Canada under an approved quality control program with inspections by APA – The Engineered Wood Association (AA-649).

6.0 Evidence Submitted:

Data in accordance with the ICC-ES Acceptance Criteria for Prefabricated Wood I-joists (AC14), dated February 2013.

7.0 Identification:

AJS® I-joists are identified by a stamp indicating the joist model; company name (Boise Cascade Wood Products, L.L.C.); manufacturing location; evaluation report number (ESR-1144); and the name and logo of the inspection agency (APA).

AJS® Joists in Commercial Projects. The 18" and deeper depth AJS® joists are intended for commercial projects with heavier design loads and longer spans. All commercial projects utilizing AJS® joists shall have an engineer or architect of record.



Boise Cascade
Engineered Wood Products

40 PSF Live Load Span Tables

Multi-Family Dwellings and Hotels: Private Rooms

No Web Stiffeners Required for Joist Depths of 16" and Less.

Web Stiffeners Required at All Bearing Locations for 18" and Deeper Joists

40 PSF Live Load + 25 PSF Dead Load

Joist Depth	Joist Series	3½" Interior Bearing				5¼" Interior Bearing			
		12" o.c.	16" o.c.	19.2" o.c.	24" o.c.	12" o.c.	16" o.c.	19.2" o.c.	24" o.c.
10½"	AJS® 20	19'-1"	17'-5"	16'-0"	14'-4"	19'-1"	17'-5"	16'-0"	14'-4"
	AJS® 19U	19'-4"	17'-8"	16'-8"	14'-4"	19'-4"	17'-8"	16'-8"	14'-4"
	AJS® 25	21'-0"	19'-1"	13'-0"	15'-9"	21'-0"	19'-1"	13'-0"	15'-9"
11⅝"	AJS® 20	22'-8"	20'-0"	16'-3"	14'-7"	22'-8"	20'-0"	13'-3"	14'-7"
	AJS® 19U	23'-0"	21'-0"	18'-3"	14'-7"	23'-0"	21'-0"	13'-3"	14'-7"
	AJS® 25	24'-11"	22'-9"	20'-1"	16'-1"	24'-11"	22'-9"	20'-1"	16'-1"
14"	AJS® 20	25'-2"	22'-0"	13'-7"	14'-10"	25'-5"	22'-0"	13'-7"	14'-10"
	AJS® 19U	26'-1"	22'-4"	15'-7"	14'-10"	26'-1"	22'-4"	13'-7"	14'-10"
	AJS® 25	28'-4"	24'-6"	20'-5"	16'-4"	28'-4"	24'-6"	20'-5"	16'-4"
16"	AJS® 20	27'-4"	22'-8"	18'-10"	15'-1"	27'-4"	22'-8"	18'-10"	15'-1"
	AJS® 190	28'-11"	22'-8"	18'-10"	15'-1"	28'-11"	22'-8"	18'-10"	15'-1"
	AJS® 25	31'-4"	25'-0"	20'-10"	16'-7"	31'-4"	25'-0"	20'-10"	16'-7"
18"	AJS® 25	34'-6"	31'-5"	28'-11"	25'-10"	34'-6"	31'-5"	28'-11"	25'-10"
	AJS® 30	35'-6"	32'-4"	30'-5"	28'-4"	35'-6"	32'-4"	30'-5"	28'-4"
20"	AJS® 25	37'-4"	33'-6"	30'-7"	27'-4"	37'-4"	33'-6"	30'-7"	27'-4"
	AJS® 30	38'-5"	35'-0"	33'-0"	30'-8"	38'-5"	35'-0"	33'-0"	30'-8"
22"	AJS® 25	40'-1"	35'-1"	32'-1"	28'-8"	40'-1"	35'-1"	32'-1"	28'-8"
	AJS® 30	41'-3"	37'-7"	35'-5"	32'-1"	41'-3"	37'-7"	35'-5"	32'-3"
24"	AJS® 25	42'-4"	36'-7"	33'-5"	29'-11"	42'-4"	36'-7"	33'-5"	29'-11"
	AJS® 30	44'-1"	40'-2"	37'-7"	32'-9"	44'-1"	40'-2"	37'-7"	33'-8"

NOTES

- Loading based upon Table 1607.1 of 2009/2012 International Building Code.
- Spans limited by allowable moment and reaction values, total load deflection of $L/240$. Live load deflection limited to $L/480$.
- Table values assume that $23/32$ " r.in. plywood/OSB rated sheathing is glued and nailed to joists.
- Table values represent the most restrictive of simple or multiple span applications.
- Table values are the maximum allowable clear distance between supports.
- Table assumes minimum 2¼" end bearing, no web stiffeners required for joist depths of 16" and less, web stiffeners required at all bearing locations for 18" and deeper joists.
- This table was designed to apply to a broad range of applications. It may be possible to exceed the limitations of this table by analyzing a specific application with the BC CALC® sizing software.

Medical/Dental: Private Rooms

Web Stiffeners Required at All Bearing Locations for Table Below

Spans without web stiffeners and/or shorter bearings are possible, analyze such conditions with BC CALC® sizing software

Worst Case 40 PSF or 1000 LB Concentrated Live Load] + 25 PSF Dead Load					
Joist Depth	Joist Series	3 1/2" Interior Bearing / 5 1/4" Interior Bearing			
		12" o.c.	16" o.c.	19.2" o.c.	24" o.c.
9 1/2"	AJS® 20	17'-7"	16'-1"	15'-0"	12'-9"
	AJS® 190	17'-10"	16'-4"	15'-4"	14'-1"
	AJS® 25	19'-4"	17'-8"	16'-7"	15'-5"
11 7/8"	AJS® 20	20'-11"	19'-1"	18'-0"	15'-4"
	AJS® 190	21'-3"	19'-5"	18'-4"	17'-0"
	AJS® 25	23'-1"	21'-0"	19'-9"	18'-5"
14"	AJS® 20	23'-9"	21'-8"	20'-1"	17'-7"
	AJS® 190	24'-2"	22'-0"	20'-9"	19'-2"
	AJS® 25	26'-2"	23'-10"	22'-5"	20'-10"
16"	AJS® 20	26'-4"	23'-8"	21'-7"	19'-4"
	AJS® 190	26'-9"	24'-5"	23'-0"	20'-8"
	AJS® 25	29'-0"	26'-4"	24'-10"	23'-1"
18"	AJS® 25	31'-11"	29'-1"	27'-5"	25'-6"
	AJS® 30	32'-10"	29'-10"	28'-2"	26'-2"
20"	AJS® 25	34'-6"	31'-6"	29'-8"	27'-4"
	AJS® 30	35'-6"	32'-4"	30'-6"	28'-4"
22"	AJS® 25	37'-1"	33'-10"	31'-11"	28'-8"
	AJS® 30	38'-2"	34'-9"	32'-9"	30'-5"
24"	AJS® 25	39'-7"	36'-1"	33'-5"	29'-11"
	AJS® 30	40'-10"	37'-2"	35'-0"	32'-7"

NOTES

- Loading based upon Table 1607.1 of 2009/2012 international Building Code.
- Spans limited by allowable moment and reaction values, total load deflection of L/240. Live load deflection limited to L/480 with 40 psf.
- Table values assume that 23/32" min. plywood/OSB rated sheathing is glued and nailed to joists.
- Table values represent the most restrictive of simple or multiple span applications.
- Table values are the maximum allowable clear distance between supports.
- Table values assume web stiffeners at each bearing location, minimum 2 1/4" end bearing.
- This table was designed to apply to a broad range of applications. It may be possible to exceed the limitations of this table by analyzing a specific application with the BC CALC® sizing software.

Concentrated Live Loads ("Safe" Loads)

The International Building Code requires certain types of commercial floors to be designed with a concentrated live load in addition to the prescribed uniform loads. This concentrated live load is applied to the floor without the uniform live load but with all dead load, creating a separate live load analysis. The concentrated load is either 2000 lb or 1000 lb, depending upon the floor type, and is applied to a 2 1/2 foot x 2 1/2 foot square area. This 2 1/2-foot square is applied on the floor such that would result in the highest shear and bending stress, and deflections. Since this load is intended to create maximum stress and deflection conditions, it is centered over a specific floor joist. Floor joists at 24" on-center will receive more load from the concentrated live load than joists spaced at smaller increments. For example, a joist at 24"

on-center will receive 2/2.5 or 80% of the concentrated load over a distance of 2'-6" along the joist length.

There have been some misconceptions in the design community on how the concentrated live load should be applied to floors. Boise Cascade EWP Engineering has consulted directly with ICC on this matter. The loads prescribed in section 1607.4 of the 2009/2012 IBC have been properly considered in the development of the relative floor/joist tables in this guide.

50 PSF Live, 15 PSF Partition & 2000 lb Conc. Load Span Tables

[Worst Case 50 PSF or 1000 LB Concentrated Live Load]
 + 15 PSF Partition Load + 25 PSF Dead Load
 Office Buildings: Office Area

Web Stiffeners Required at All Bearing Locations for Table Below

Spans without web stiffeners and/or shorter bearings are possible, analyze such conditions with BC CALC® sizing software.

[Worst Case 50 PSF or 1000 LB Concentrated Live Load] + 15 PSF Partition Load + 25 PSF Dead Load									
Joist Depth	Joist Series	3½" Interior Bearing				5¼" Interior Bearing			
		12" o.c.	16" o.c.	19.2" o.c.	24" o.c.	12" o.c.	16" o.c.	19.2" o.c.	24" o.c.
9½"	AJS® 20	14'-7"	11'-7"	10'-0"	4'-11"	14'-7"	11'-7"	10'-0"	4'-11"
	AJS® 190	16'-3"	12'-11"	10'-2"	4'-11"	16'-3"	12'-11"	10'-2"	4'-11"
	AJS® 25	17'-11"	16'-3"	10'-2"	4'-11"	17'-11"	16'-3"	10'-2"	4'-11"
11⅝"	AJS® 20	17'-10"	14'-3"	12'-4"	6'-1"	17'-10"	14'-3"	12'-4"	6'-1"
	AJS® 190	19'-8"	15'-10"	13'-5"	6'-1"	19'-8"	15'-10"	13'-5"	6'-1"
	AJS® 25	21'-4"	19'-4"	13'-5"	6'-1"	21'-4"	19'-4"	13'-5"	6'-1"
14"	AJS® 20	20'-8"	16'-6"	14'-3"	7'-5"	20'-8"	16'-6"	14'-3"	7'-5"
	AJS® 190	22'-4"	18'-4"	15'-11"	7'-5"	22'-4"	18'-4"	15'-11"	7'-5"
	AJS® 25	24'-2"	22'-0"	16'-10"	7'-5"	24'-2"	22'-0"	16'-10"	7'-5"
16"	AJS® 20	23'-2"	18'-6"	16'-0"	9'-1"	23'-2"	18'-6"	16'-0"	9'-1"
	AJS® 190	24'-9"	20'-7"	17'-10"	9'-1"	24'-9"	20'-7"	17'-10"	9'-1"
	AJS® 25	26'-9"	24'-4"	20'-5"	9'-1"	26'-9"	24'-4"	20'-5"	9'-1"
18"	AJS® 25	29'-6"	26'-10"	24'-7"	20'-10"	29'-6"	26'-10"	24'-7"	20'-10"
	AJS® 30	30'-4"	27'-7"	26'-0"	20'-10"	30'-4"	27'-7"	26'-0"	20'-10"
20"	AJS® 25	31'-11"	28'-6"	26'-0"	22'-7"	31'-11"	28'-6"	26'-0"	22'-7"
	AJS® 30	32'-10"	29'-11"	28'-2"	22'-7"	32'-10"	29'-11"	28'-2"	22'-7"
22"	AJS® 25	34'-4"	29'-10"	27'-3"	23'-1"	34'-4"	29'-10"	27'-3"	24'-4"
	AJS® 30	35'-4"	32'-1"	28'-11"	23'-1"	35'-4"	32'-1"	30'-3"	24'-4"
24"	AJS® 25	35'-11"	31'-1"	28'-5"	23'-8"	35'-11"	31'-1"	28'-5"	25'-4"
	AJS® 30	37'-9"	34'-4"	29'-7"	23'-8"	37'-9"	34'-4"	31'-11"	26'-1"

NOTES

- Loading based upon Table 1607.1 of 2009/2012 International Building Code
- Spans limited by allowable moment and reaction values, total load deflection of L/240. Live load deflection limited to L/600 with 50 psf, L/360 with 50 + 15 psf.
- Table values assume that 2³/₃₂" min. plywood/OSB rated sheathing is glued and nailed to joists.
- Table values represent the most restrictive of simple or multiple span applications.
- Table values are the maximum allowable clear distance between supports.
- Table values assume web stiffeners at each bearing location, minimum 2¼" end bearing.
- This table was designed to apply to a broad range of applications. It may be possible to exceed the limitations of this table by analyzing a specific application with the BC CALC® sizing software.

Deflection Criteria for Commercial Floors

The minimum deflection criterion for commercial floors is the same as for residential floors, L/360 for live load deflection and L/240 for total load deflection. Since deflection controls a significant amount of joist design, an additional deflection limit has been considered in the development of the AJS® joist span tables shown in this guide. In addition to the minimum limits at full uniform and concentrated (safe) live loads, deflection is limited to L/600 with a uniform live load of 50 psf in those tables where the code specified uniform live load is 50 psf or greater. As is the case with all joist designs, floor performance should always be considered by the design professional of record in each specific condition.

Medical/Dental: Operating Rooms & Laboratory
Library: Reading Rooms

[Worst Case 60 PSF or 1000 LB Concentrated Live Load] + 25 PSF Dead Load

Joist Depth	Joist Series	3½" Interior Bearing				5¼" Interior Bearing			
		12" o.c.	16" o.c.	19.2" o.c.	24" o.c.	12" o.c.	16" o.c.	19.2" o.c.	24" o.c.
9½"	AJS® 20	16'-3"	14'-10"	14'-3"	11'-5"	16'-3"	14'-10"	14'-0"	11'-5"
	AJS® 190	16'-3"	15'-0"	14'-2"	11'-5"	16'-3"	15'-0"	14'-2"	11'-5"
	AJS® 25	17'-1"	16'-3"	15'-4"	13'-3"	17'-11"	16'-3"	15'-4"	13'-3"
11⅞"	AJS® 20	19'-4"	17'-6"	16'-0"	13'-1"	19'-4"	17'-6"	16'-0"	13'-1"
	AJS® 190	19'-8"	17'-11"	16'-4"	13'-1"	19'-8"	17'-11"	16'-4"	13'-1"
	AJS® 25	21'-4"	19'-4"	18'-3"	14'-11"	21'-4"	19'-4"	18'-3"	14'-11"
14"	AJS® 20	22'-0"	19'-2"	17'-6"	14'-7"	22'-0"	19'-2"	17'-6"	14'-7"
	AJS® 190	22'-4"	20'-4"	18'-3"	14'-7"	22'-4"	20'-4"	18'-3"	14'-7"
	AJS® 25	24'-2"	22'-0"	20'-6"	16'-4"	24'-2"	22'-0"	20'-6"	16'-4"
16"	AJS® 20	23'-1"	20'-8"	18'-1"	16'-0"	23'-11"	20'-8"	18'-11"	16'-0"
	AJS® 190	24'-9"	22'-2"	20'-1"	16'-0"	24'-9"	22'-2"	20'-1"	16'-0"
	AJS® 25	26'-9"	24'-4"	22'-3"	17'-9"	26'-9"	24'-4"	22'-3"	17'-9"
18"	AJS® 25	29'-6"	26'-10"	25'-3"	22'-1"	29'-6"	26'-10"	25'-3"	22'-1"
	AJS® 30	30'-4"	27'-1"	26'-0"	22'-1"	30'-4"	27'-1"	26'-0"	22'-1"
20"	AJS® 25	31'-11"	29'-1"	26'-9"	23'-11"	31'-11"	29'-1"	26'-9"	23'-11"
	AJS® 30	32'-11"	29'-11"	28'-2"	23'-11"	32'-11"	29'-11"	28'-2"	23'-11"
22"	AJS® 25	34'-4"	30'-3"	28'-0"	24'-6"	34'-4"	30'-3"	28'-0"	25'-0"
	AJS® 30	35'-4"	32'-1"	30'-3"	24'-6"	35'-4"	32'-1"	30'-3"	25'-9"
24"	AJS® 25	36'-8"	32'-0"	29'-2"	25'-0"	36'-8"	32'-0"	29'-2"	26'-1"
	AJS® 30	37'-9"	34'-4"	31'-4"	25'-0"	37'-9"	34'-4"	32'-4"	27'-8"

Web Stiffeners Required at All Bearing Locations for Table Below
Spans without web stiffeners and/or shorter bearings are possible, analyze such conditions with BC CALC® sizing software.

NOTES FOR BOTH TABLES

- Loading based upon Table 1607.1 of 2009/2012 International Building Code.
- Spans limited by allowable moment and reaction values. total load deflection of L/240. Live load deflection limited to L/600 with 50 psf and L/360 with listed uniform live load.
- Table values assume that 23/32" min. plywood/OSB rated sheathing is glued and nailed to joists.
- Table values represent the most restrictive of simple or multiple span applications.
- Table values are the maximum allowable clear distance between supports.
- Table values assume web stiffeners at each bearing location, minimum 2¼" end bearing.
- This table was designed to apply to a broad range of applications. It may be possible to exceed the limitations of this table by analyzing a specific application with the BC CALC® sizing software.

Retail: Upper Floors

[Worst Case 75 PSF or 1000 LB Concentrated Live Load] + 25 PSF Dead Load

Joist Depth	Joist Series	3½" Interior Bearing				5¼" Interior Bearing			
		12" o.c.	16" o.c.	19.2" o.c.	24" o.c.	12" o.c.	16" o.c.	19.2" o.c.	24" o.c.
9½"	AJS® 20	16'-3"	14'-2"	12'-2"	9'-8"	16'-3"	14'-2"	12'-2"	9'-8"
	AJS® 190	16'-6"	14'-7"	12'-2"	9'-8"	16'-6"	14'-7"	12'-2"	9'-8"
	AJS® 25	17'-11"	16'-3"	14'-2"	11'-3"	17'-11"	16'-3"	14'-2"	11'-3"
11⅞"	AJS® 20	18'-8"	16'-1"	13'-11"	11'-1"	18'-8"	16'-1"	13'-11"	11'-1"
	AJS® 190	19'-8"	16'-8"	13'-11"	11'-1"	19'-8"	16'-8"	13'-11"	11'-1"
	AJS® 25	21'-4"	19'-0"	15'-10"	12'-8"	21'-4"	19'-0"	15'-10"	12'-8"
14"	AJS® 20	20'-5"	17'-8"	15'-6"	12'-5"	20'-5"	17'-8"	15'-6"	12'-5"
	AJS® 190	21'-11"	18'-8"	15'-6"	12'-5"	21'-11"	18'-8"	15'-6"	12'-5"
	AJS® 25	24'-2"	20'-11"	17'-5"	13'-11"	24'-2"	20'-11"	17'-5"	13'-11"
16"	AJS® 20	22'-0"	19'-1"	17'-1"	13'-7"	22'-0"	19'-1"	17'-1"	13'-7"
	AJS® 190	23'-7"	20'-5"	17'-1"	13'-7"	23'-7"	20'-5"	17'-1"	13'-7"
	AJS® 25	26'-9"	22'-8"	18'-11"	15'-1"	26'-9"	22'-8"	18'-11"	15'-1"
18"	AJS® 25	29'-6"	25'-6"	23'-4"	18'-9"	29'-6"	25'-6"	23'-4"	18'-9"
	AJS® 30	30'-4"	27'-7"	23'-6"	18'-9"	30'-4"	27'-7"	23'-6"	18'-9"
20"	AJS® 25	31'-2"	27'-0"	24'-8"	20'-4"	31'-2"	27'-0"	24'-8"	20'-4"
	AJS® 30	32'-10"	29'-11"	25'-5"	20'-4"	32'-10"	29'-11"	25'-5"	20'-4"
22"	AJS® 25	32'-8"	28'-3"	25'-10"	20'-10"	32'-8"	28'-3"	25'-10"	21'-11"
	AJS® 30	35'-4"	31'-3"	26'-0"	20'-10"	35'-4"	31'-10"	27'-5"	21'-11"
24"	AJS® 25	34'-1"	29'-6"	26'-7"	21'-3"	34'-1"	29'-6"	26'-11"	23'-6"
	AJS® 30	37'-9"	31'-11"	26'-7"	21'-3"	37'-9"	33'-3"	29'-5"	23'-6"

Medical, Schools, Libraries: Upper Floor Corridors									
[Worst Case 80 PSF or 1000 LB Concentrated Live Load] + 25 PSF Dead Load									
Joist Depth	Joist Series	3½" Interior Bearing				5¼" Interior Bearing			
		12" o.c.	16" o.c.	19.2" o.c.	24" o.c.	12" o.c.	16" o.c.	19.2" o.c.	24" o.c.
9½"	AJS® 20	15'-11"	13'-10"	11'-6"	9'-3"	15'-11"	13'-10"	11'-6"	9'-3"
	AJS® 190	16'-6"	13'-11"	11'-6"	9'-3"	16'-6"	13'-11"	11'-6"	9'-3"
	AJS® 25	17'-11"	16'-2"	13'-5"	10'-9"	17'-11"	16'-2"	13'-5"	10'-9"
11⅞"	AJS® 20	18'-2"	15'-9"	13'-3"	10'-6"	18'-2"	15'-9"	13'-3"	10'-6"
	AJS® 190	19'-6"	15'-11"	13'-3"	10'-6"	19'-6"	15'-11"	13'-3"	10'-6"
	AJS® 25	21'-4"	18'-1"	15'-1"	12'-0"	21'-4"	18'-1"	15'-1"	12'-0"
14"	AJS® 20	20'-0"	17'-3"	14'-9"	11'-10"	20'-0"	17'-3"	14'-9"	11'-10"
	AJS® 190	21'-5"	17'-9"	14'-9"	11'-10"	21'-5"	17'-9"	14'-9"	11'-10"
	AJS® 25	24'-2"	19'-11"	16'-7"	13'-3"	24'-2"	19'-11"	16'-7"	13'-3"
16"	AJS® 20	21'-6"	18'-7"	16'-3"	13'-0"	21'-6"	18'-7"	16'-3"	13'-0"
	AJS® 190	23'-0"	19'-6"	16'-3"	13'-0"	23'-0"	19'-6"	16'-3"	13'-0"
	AJS® 25	26'-9"	21'-7"	18'-0"	14'-4"	26'-9"	21'-7"	18'-0"	14'-4"
18"	AJS® 25	28'-10"	24'-11"	22'-4"	17'-10"	28'-10"	24'-11"	22'-4"	17'-10"
	AJS® 30	30'-4"	26'-10"	22'-4"	17'-10"	30'-4"	26'-10"	22'-4"	17'-10"
20"	AJS® 25	30'-5"	26'-4"	24'-1"	19'-4"	30'-5"	26'-4"	24'-1"	19'-4"
	AJS® 30	32'-10"	29'-1"	24'-2"	19'-4"	32'-10"	29'-1"	24'-2"	19'-4"
22"	AJS® 25	31'-11"	27'-7"	24'-9"	19'-10"	31'-11"	27'-7"	25'-2"	20'-10"
	AJS® 30	35'-4"	29'-9"	24'-9"	19'-10"	35'-4"	31'-1"	26'-1"	20'-10"
24"	AJS® 25	33'-3"	28'-9"	25'-4"	20'-3"	33'-3"	28'-9"	26'-3"	22'-4"
	AJS® 30	37'-5"	30'-5"	25'-4"	20'-3"	37'-5"	32'-5"	28'-0"	22'-4"

Web Stiffeners Required at All Bearing Locations for Table Below
Spans without web stiffeners and/or shorter bearings are possible, analyze such conditions with BC CALC® sizing software.

NOTES FOR BOTH TABLES

- Loading based upon Table 1607.1 of 2009/2012 International Building Code.
- Spans limited by allowable moment and reaction values, total load deflection of L/240. Live load deflection limited to L/600 with 50 psf and L/360 with listed uniform live load.
- Table values assume that 23/32" min. plywood/OSB rated sheathing is glued and nailed to joists.
- Table values represent the most restrictive of simple or multiple span applications.
- Table values are the maximum allowable clear distance between supports.
- Table values assume web stiffeners at each bearing location, minimum 2¼" end bearing.
- This table was designed to apply to a broad range of applications. It may be possible to exceed the limitations of this table by analyzing a specific application with the BC CALC® sizing software.

Retail - 1st Floor / Schools - 1st Floor Corridors									
[Worst Case 100 PSF or 1000 LB Concentrated Live Load] + 25 PSF Dead Load									
Joist Depth	Joist Series	3½" Interior Bearing				5¼" Interior Bearing			
		12" o.c.	16" o.c.	19.2" o.c.	24" o.c.	12" o.c.	16" o.c.	19.2" o.c.	24" o.c.
9½"	AJS® 20	14'-7"	11'-8"	9'-8"	7'-9"	14'-7"	11'-8"	9'-8"	7'-9"
	AJS® 190	15'-5"	11'-8"	9'-8"	7'-9"	15'-5"	11'-8"	9'-8"	7'-9"
	AJS® 25	16'-9"	13'-7"	11'-3"	9'-0"	16'-9"	13'-7"	11'-3"	9'-0"
11⅞"	AJS® 20	16'-8"	13'-4"	11'-1"	8'-10"	16'-8"	13'-4"	11'-1"	8'-10"
	AJS® 190	17'-10"	13'-4"	11'-1"	8'-10"	17'-10"	13'-4"	11'-1"	8'-10"
	AJS® 25	19'-11"	15'-2"	12'-8"	10'-1"	19'-11"	15'-2"	12'-8"	10'-1"
14"	AJS® 20	18'-3"	14'-11"	12'-5"	9'-11"	18'-3"	14'-11"	12'-5"	9'-11"
	AJS® 190	19'-7"	14'-11"	12'-5"	9'-11"	19'-7"	14'-11"	12'-5"	9'-11"
	AJS® 25	22'-3"	16'-8"	13'-11"	11'-1"	22'-3"	16'-8"	13'-11"	11'-1"
16"	AJS® 20	19'-8"	16'-4"	13'-7"	10'-10"	19'-8"	16'-4"	13'-7"	10'-10"
	AJS® 190	21'-1"	16'-4"	13'-7"	10'-10"	21'-1"	16'-4"	13'-7"	10'-10"
	AJS® 25	24'-2"	18'-1"	15'-1"	12'-0"	24'-2"	18'-1"	15'-1"	12'-0"
18"	AJS® 25	26'-5"	22'-6"	18'-9"	15'-0"	26'-5"	22'-6"	18'-9"	15'-0"
	AJS® 30	28'-5"	22'-6"	18'-9"	15'-0"	28'-5"	22'-6"	18'-9"	15'-0"
20"	AJS® 25	27'-11"	24'-2"	20'-4"	16'-3"	27'-11"	24'-2"	20'-4"	16'-3"
	AJS® 30	30'-10"	24'-5"	20'-4"	16'-3"	30'-10"	24'-5"	20'-4"	16'-3"
22"	AJS® 25	29'-3"	25'-0"	20'-10"	16'-7"	29'-3"	25'-3"	21'-11"	17'-6"
	AJS® 30	32'-11"	25'-0"	20'-10"	16'-7"	32'-11"	26'-4"	21'-11"	17'-6"
24"	AJS® 25	30'-6"	25'-6"	21'-3"	17'-0"	30'-6"	26'-4"	23'-6"	18'-9"
	AJS® 30	34'-1"	25'-6"	21'-3"	17'-0"	34'-4"	28'-2"	23'-6"	18'-9"

Office: Upper Floor Corridors

Web Stiffeners Required at All Bearing Locations for Table Below

Spans without web stiffeners and/or shorter bearings are possible, analyze such conditions with BC CALC® sizing software.

[Worst Case 80 PSF or 2000 LB Concentrated Live Load] + 25 PSF Dead Load

Joist Depth	Joist Series	3½" Interior Bearing				5¼" Interior Bearing			
		12" o.c.	16" o.c.	19.2" o.c.	24" o.c.	12" o.c.	16" o.c.	19.2" o.c.	24" o.c.
9½"	AJS® 20	14'-7"	11'-7"	10'-0"	4'-11"	14'-7"	11'-7"	10'-0"	4'-11"
	AJS® 190	16'-3"	12'-11"	10'-2"	4'-11"	16'-3"	12'-11"	10'-2"	4'-11"
	AJS® 25	17'-11"	16'-2"	10'-2"	4'-11"	17'-11"	16'-2"	10'-2"	4'-11"
11⅞"	AJS® 20	17'-10"	14'-3"	12'-4"	6'-1"	17'-10"	14'-3"	12'-4"	6'-1"
	AJS® 190	19'-6"	15'-10"	13'-3"	6'-1"	19'-6"	15'-10"	13'-3"	6'-1"
	AJS® 25	21'-4"	18'-1"	13'-5"	6'-1"	21'-4"	18'-1"	13'-5"	6'-1"
14"	AJS® 20	20'-0"	16'-6"	14'-3"	7'-5"	20'-0"	16'-6"	14'-3"	7'-5"
	AJS® 190	21'-5"	17'-9"	14'-9"	7'-5"	21'-5"	17'-9"	14'-9"	7'-5"
	AJS® 25	24'-2"	19'-11"	16'-7"	7'-5"	24'-2"	19'-11"	16'-7"	7'-5"
16"	AJS® 20	21'-6"	18'-6"	16'-0"	9'-1"	21'-6"	18'-6"	16'-0"	9'-1"
	AJS® 190	23'-0"	19'-6"	16'-3"	9'-1"	23'-0"	19'-6"	16'-3"	9'-1"
	AJS® 25	26'-9"	21'-7"	18'-0"	9'-1"	26'-9"	21'-7"	18'-0"	9'-1"
18"	AJS® 25	28'-10"	24'-11"	22'-4"	17'-10"	28'-10"	24'-11"	22'-4"	17'-10"
	AJS® 30	30'-4"	26'-10"	22'-4"	17'-10"	30'-4"	26'-10"	22'-4"	17'-10"
20"	AJS® 25	30'-5"	26'-4"	24'-1"	19'-4"	30'-5"	26'-4"	24'-1"	19'-4"
	AJS® 30	32'-10"	29'-1"	24'-2"	19'-4"	32'-10"	29'-1"	24'-2"	19'-4"
22"	AJS® 25	31'-11"	27'-7"	24'-9"	19'-10"	31'-11"	27'-7"	25'-2"	20'-10"
	AJS® 30	35'-4"	29'-9"	24'-9"	19'-10"	35'-4"	31'-1"	26'-1"	20'-10"
24"	AJS® 25	33'-3"	28'-9"	25'-4"	20'-3"	33'-3"	28'-9"	26'-3"	22'-4"
	AJS® 30	37'-5"	30'-5"	25'-4"	20'-3"	37'-5"	32'-5"	28'-0"	22'-4"

NOTES

- Loading based upon Table 1607.1 of 2009/2012 International Building Code.
- Spans limited by allowable moment and reaction values, total load deflection of L/240. Live load deflection limited to L/600 with 50 psf and L/360 with 80 psf.
- Table values assume that 23/32" min. plywood/OSB rated sheathing is glued and nailed to joists.
- Table values represent the most restrictive of simple or multiple span applications.
- Table values are the maximum allowable clear distance between supports.
- Table values assume web stiffeners at each bearing location, minimum 2¼" end bearing.
- This table was designed to apply to a broad range of applications. It may be possible to exceed the limitations of this table by analyzing a specific application with the BC CALC® sizing software.

100 PSF Live Load Span Tables

Hotels: Public Rooms & Corridors
Retail - All Corridors; Medical - 1st Floor Corridors
Restaurants & Dining Rooms

Assembly Areas & Theatres: Lobbies, Movable Seat Areas

Web Stiffeners Required at All Bearing Locations for Table Below

Spans without web stiffeners and/or shorter bearings are possible, analyze such conditions with BC CALC® sizing software.

100 PSF Live Load + 25 PSF Dead Load

Joist Depth	Joist Series	3½" Interior Bearing				5¼" Interior Bearing			
		12" o.c.	16" o.c.	19.2" o.c.	24" o.c.	12" o.c.	16" o.c.	19.2" o.c.	24" o.c.
9½"	AJS® 20	14'-7"	11'-8"	9'-8"	7'-9"	14'-7"	11'-8"	9'-8"	7'-9"
	AJS® 190	15'-5"	11'-8"	9'-8"	7'-9"	15'-5"	11'-8"	9'-8"	7'-9"
	AJS® 25	16'-9"	13'-7"	11'-3"	9'-0"	16'-9"	13'-7"	11'-3"	9'-0"
11⅞"	AJS® 20	16'-8"	13'-4"	11'-1"	8'-10"	16'-8"	13'-4"	11'-1"	8'-10"
	AJS® 190	17'-10"	13'-4"	11'-1"	8'-10"	17'-10"	13'-4"	11'-1"	8'-10"
	AJS® 25	19'-11"	15'-2"	12'-8"	10'-1"	19'-11"	15'-2"	12'-8"	10'-1"
14"	AJS® 20	18'-3"	14'-11"	12'-5"	9'-11"	18'-3"	14'-11"	12'-5"	9'-11"
	AJS® 190	19'-7"	14'-11"	12'-5"	9'-11"	19'-7"	14'-11"	12'-5"	9'-11"
	AJS® 25	22'-3"	16'-8"	13'-11"	11'-1"	22'-3"	16'-8"	13'-11"	11'-1"
16"	AJS® 20	19'-8"	16'-4"	13'-7"	10'-10"	19'-8"	16'-4"	13'-7"	10'-10"
	AJS® 190	21'-1"	16'-4"	13'-7"	10'-10"	21'-1"	16'-4"	13'-7"	10'-10"
	AJS® 25	24'-2"	18'-1"	15'-1"	12'-0"	24'-2"	18'-1"	15'-1"	12'-0"
18"	AJS® 25	26'-5"	22'-6"	18'-9"	15'-0"	26'-5"	22'-6"	18'-9"	15'-0"
	AJS® 30	28'-5"	22'-6"	18'-9"	15'-0"	28'-5"	22'-6"	18'-9"	15'-0"
20"	AJS® 25	27'-11"	24'-2"	20'-4"	16'-3"	27'-11"	24'-2"	20'-4"	16'-3"
	AJS® 30	30'-10"	24'-5"	20'-4"	16'-3"	30'-10"	24'-5"	20'-4"	16'-3"
22"	AJS® 25	29'-3"	25'-0"	20'-10"	16'-7"	29'-3"	25'-3"	21'-11"	17'-6"
	AJS® 30	32'-11"	25'-0"	20'-10"	16'-7"	32'-11"	26'-4"	21'-11"	17'-6"
24"	AJS® 25	30'-6"	25'-6"	21'-3"	17'-0"	30'-6"	26'-4"	23'-6"	18'-9"
	AJS® 30	34'-1"	25'-6"	21'-3"	17'-0"	34'-4"	28'-2"	23'-6"	18'-9"

NOTES

- Loading based upon Table 1607.1 of 2009/2012 International Building Code.
- Spans limited by allowable moment and reaction values, total load deflection of L/240. Live load deflection limited to L/600 with 50 psf and L/360 with 100 psf.
- Table values assume that 23/32" min. plywood/OSB rated sheathing is glued and nailed to joists.
- Table values represent the most restrictive of simple or multiple span applications.
- Table values are the maximum allowable clear distance between supports.
- Table values assume web stiffeners at each bearing location, minimum 2¼" end bearing.
- This table was designed to apply to a broad range of applications. It may be possible to exceed the limitations of this table by analyzing a specific application with the BC CALC® sizing software.

Office: Lobbies & 1st Floor Corridors

Web Stiffeners Required at All Bearing Locations for Table Below

Spans without web stiffeners and/or shorter bearings are possible, analyze such conditions with BC CALC® sizing software.

[Worst Case 100 PSF or 2000 LB Concentrated Live Load] + 25 PSF Dead Load

Joist Depth	Joist Series	3½" Interior Bearing				5¼" Interior Bearing			
		12" o.c.	16" o.c.	19.2" o.c.	24" o.c.	12" o.c.	16" o.c.	19.2" o.c.	24" o.c.
9½"	AJS® 20	14'-7"	11'-7"	9'-8"	4'-11"	14'-7"	11'-7"	9'-8"	4'-11"
	AJS® 190	15'-5"	11'-8"	9'-8"	4'-11"	15'-5"	11'-8"	9'-8"	4'-11"
	AJS® 25	16'-9"	13'-7"	10'-2"	4'-11"	16'-9"	13'-7"	10'-2"	4'-11"
11⅞"	AJS® 20	16'-8"	13'-4"	11'-1"	6'-1"	16'-8"	13'-4"	11'-1"	6'-1"
	AJS® 190	17'-10"	13'-4"	11'-1"	6'-1"	17'-10"	13'-4"	11'-1"	6'-1"
	AJS® 25	19'-11"	15'-2"	12'-8"	6'-1"	19'-11"	15'-2"	12'-8"	6'-1"
14"	AJS® 20	18'-3"	14'-11"	12'-5"	7'-5"	18'-3"	14'-11"	12'-5"	7'-5"
	AJS® 190	19'-7"	14'-11"	12'-5"	7'-5"	19'-7"	14'-11"	12'-5"	7'-5"
	AJS® 25	22'-3"	16'-8"	13'-11"	7'-5"	22'-3"	16'-8"	13'-11"	7'-5"
16"	AJS® 20	19'-8"	16'-4"	13'-7"	9'-1"	19'-8"	16'-4"	13'-7"	9'-1"
	AJS® 190	21'-1"	16'-4"	13'-7"	9'-1"	21'-1"	16'-4"	13'-7"	9'-1"
	AJS® 25	24'-2"	18'-1"	15'-1"	9'-1"	24'-2"	18'-1"	15'-1"	9'-1"
18"	AJS® 25	26'-5"	22'-6"	18'-9"	15'-0"	26'-5"	22'-6"	18'-9"	15'-0"
	AJS® 30	28'-5"	22'-6"	18'-9"	15'-0"	28'-5"	22'-6"	18'-9"	15'-0"
20"	AJS® 25	27'-11"	24'-2"	20'-4"	16'-3"	27'-11"	24'-2"	20'-4"	16'-3"
	AJS® 30	30'-10"	24'-5"	20'-4"	16'-3"	30'-10"	24'-5"	20'-4"	16'-3"
22"	AJS® 25	29'-3"	25'-0"	20'-10"	16'-7"	29'-3"	25'-3"	21'-11"	17'-6"
	AJS® 30	32'-11"	25'-0"	20'-10"	16'-7"	32'-11"	26'-4"	21'-11"	17'-6"
24"	AJS® 25	30'-6"	25'-6"	21'-3"	17'-0"	30'-6"	26'-4"	23'-6"	18'-9"
	AJS® 30	34'-1"	25'-6"	21'-3"	17'-0"	34'-4"	28'-2"	23'-6"	18'-9"

NOTES

- Loading based upon Table 1607.1 of 2009/2012 International Building Code.
- Spans limited by allowable moment and reaction values, total load deflection of L/240. Live load deflection limited to L/600 with 50 psf and L/360 with 100 psf.
- Table values assume that 23/32" min. plywood/OSB rated sheathing is glued and nailed to joists.
- Table values represent the most restrictive of simple or multiple span applications.
- Table values are the maximum allowable clear distance between supports.
- Table values assume web stiffeners at each bearing location, minimum 2¼" end bearing.
- This table was designed to apply to a broad range of applications. It may be possible to exceed the limitations of this table by analyzing a specific application with the BC CALC® sizing software.

125 PSF Live Load (Light Storage) Span Tables

Web Stiffeners Required at All Bearing Locations for Table Below
 Spans without web stiffeners and/or shorter bearings are possible, analyze such conditions with BC CALC® sizing software
 125 PSF Live Load + 25 PSF Dead Load

Joist Depth	Joist Series	3½" Interior Bearing				5¼" Interior Bearing			
		12" o.c.	16" o.c.	19.2" o.c.	24" o.c.	12" o.c.	16" o.c.	19.2" o.c.	24" o.c.
9½"	AJS® 20	12'-11"	9'-8"	8'-0"	6'-5"	12'-11"	9'-8"	8'-0"	6'-5"
	AJS® 190	12'-11"	9'-8"	8'-0"	6'-5"	12'-11"	9'-8"	8'-0"	6'-5"
	AJS® 25	15'-1"	11'-3"	9'-5"	7'-6"	15'-1"	11'-3"	9'-5"	7'-6"
11⅞"	AJS® 20	14'-10"	11'-1"	9'-3"	7'-4"	14'-10"	11'-1"	9'-3"	7'-4"
	AJS® 190	14'-10"	11'-1"	9'-3"	7'-4"	14'-10"	11'-1"	9'-3"	7'-4"
	AJS® 25	16'-11"	12'-8"	10'-6"	8'-5"	16'-11"	12'-8"	10'-6"	8'-5"
14"	AJS® 20	16'-7"	12'-5"	10'-4"	8'-3"	16'-7"	12'-5"	10'-4"	8'-3"
	AJS® 190	16'-7"	12'-5"	10'-4"	8'-3"	16'-7"	12'-5"	10'-4"	8'-3"
	AJS® 25	18'-7"	13'-11"	11'-6"	9'-3"	18'-7"	13'-11"	11'-6"	9'-3"
16"	AJS® 20	18'-0"	13'-7"	11'-4"	9'-0"	18'-0"	13'-7"	11'-4"	9'-0"
	AJS® 190	18'-2"	13'-7"	11'-4"	9'-0"	18'-2"	13'-7"	11'-4"	9'-0"
	AJS® 25	20'-2"	15'-1"	12'-6"	10'-0"	20'-2"	15'-1"	12'-6"	10'-0"
18"	AJS® 25	24'-1"	18'-9"	15'-7"	12'-6"	24'-1"	18'-9"	15'-7"	12'-6"
	AJS® 30	25'-1"	18'-9"	15'-7"	12'-6"	25'-1"	18'-9"	15'-7"	12'-6"
20"	AJS® 25	25'-5"	20'-4"	16'-11"	13'-6"	25'-5"	20'-4"	16'-11"	13'-6"
	AJS® 30	27'-2"	20'-4"	16'-11"	13'-6"	27'-2"	20'-4"	16'-11"	13'-6"
22"	AJS® 25	26'-8"	20'-10"	17'-4"	13'-10"	26'-8"	21'-11"	18'-3"	14'-7"
	AJS® 30	27'-9"	20'-10"	17'-4"	13'-10"	29'-3"	21'-11"	18'-3"	14'-7"
24"	AJS® 25	27'-10"	21'-3"	17'-8"	14'-2"	27'-10"	23'-6"	19'-7"	15'-7"
	AJS® 30	28'-5"	21'-3"	17'-8"	14'-2"	31'-4"	23'-6"	19'-7"	15'-7"

NOTES

- Loading based upon Light Storage - Table 1607.1 of 2009/2012 International Building Code.
- Spans limited by allowable moment and reaction values, total load deflection of L/240. Live load deflection limited to L/600 with 50 psf and L/360 with 125 psf.
- Table values assume that 23/32" min. plywood/OSB rated sheathing is glued and nailed to joists.
- Table values represent the most restrictive of simple or multiple span applications.
- Table values are the maximum allowable clear distance between supports.
- Table values assume web stiffeners at each bearing location, minimum 2¼" end bearing.
- This table was designed to apply to a broad range of applications. It may be possible to exceed the limitations of this table by analyzing a specific application with the BC CALC® sizing software.

Web Stiffeners Required at All Bearing Locations for Table Below
 Spans without web stiffeners and/or shorter bearings are possible, analyze such conditions with BC CALC® sizing software.
 250 PSF Live Load + 25 PSF Dead Load

Joist Depth	Joist Series	3½" Interior Bearing			5¼" Interior Bearing		
		12" o.c.	16" o.c.	19.2" o.c.	12" o.c.	16" o.c.	19.2" o.c.
9½"	AJS® 20	7'-0"	5'-3"	4'-4"	7'-0"	5'-3"	4'-4"
	AJS® 190	7'-0"	5'-3"	4'-4"	7'-0"	5'-3"	4'-4"
	AJS® 25	8'-2"	6'-1"	5'-1"	8'-2"	6'-1"	5'-1"
11⅞"	AJS® 20	8'-0"	6'-0"	5'-0"	8'-0"	6'-0"	5'-0"
	AJS® 190	8'-0"	6'-0"	5'-0"	8'-0"	6'-0"	5'-0"
	AJS® 25	9'-2"	6'-10"	5'-8"	9'-2"	6'-10"	5'-8"
14"	AJS® 20	9'-0"	6'-8"	5'-7"	9'-0"	6'-8"	5'-7"
	AJS® 190	9'-0"	6'-8"	5'-7"	9'-0"	6'-8"	5'-7"
	AJS® 25	10'-1"	7'-6"	6'-3"	10'-1"	7'-6"	6'-3"
16"	AJS® 20	9'-10"	7'-4"	6'-1"	9'-10"	7'-4"	6'-1"
	AJS® 190	9'-10"	7'-4"	6'-1"	9'-10"	7'-4"	6'-1"
	AJS® 25	10'-11"	8'-2"	6'-9"	10'-11"	8'-2"	6'-9"
18"	AJS® 25	13'-7"	10'-2"	8'-5"	13'-7"	10'-2"	8'-5"
	AJS® 30	13'-7"	10'-2"	8'-5"	13'-7"	10'-2"	8'-5"
20"	AJS® 25	14'-9"	11'-0"	9'-2"	14'-9"	11'-0"	9'-2"
	AJS® 30	14'-9"	11'-0"	9'-2"	14'-9"	11'-0"	9'-2"
22"	AJS® 25	15'-1"	11'-3"	9'-5"	15'-11"	11'-11"	9'-11"
	AJS® 30	15'-1"	11'-3"	9'-5"	15'-11"	11'-11"	9'-11"
24"	AJS® 25	15'-5"	11'-6"	9'-7"	17'-0"	12'-9"	10'-7"
	AJS® 30	15'-5"	11'-6"	9'-7"	17'-0"	12'-9"	10'-7"

NOTES

- Loading based upon Heavy Storage - Table 1607.1 of 2009/2012 International Building Code.
- Spans limited by allowable moment and reaction values, total load deflection of L/240. Live load deflection limited to L/600 with 50 psf and L/360 with 250 psf.
- Table values assume that 23/32" min. plywood/OSB rated sheathing is glued and nailed to joists.
- Table values represent the most restrictive of simple or multiple span applications.
- Table values are the maximum allowable clear distance between supports.
- Table values assume web stiffeners at each bearing location, minimum 2¼" end bearing.
- This table was designed to apply to a broad range of applications. It may be possible to exceed the limitations of this table by analyzing a specific application with the BC CALC® sizing software.

AJS® Joists

NOTE

The illustration below is showing several suggested applications for the Boise Cascade EWP products. It is not intended to show an actual house under construction.

NO MIDSPAN BRACING IS REQUIRED FOR ALL AJS® PRODUCTS

FOR INSTALLATION STABILITY, Temporary strut lines (1x4 min.) S' on center 12". Fasten at each joist with 2 8d nails minimum.

Dimension Lumber is not suitable for use as a rim board in ALLJOIST® floor systems.

AJS® rim joist. See page 16.

BOISE CASCADE® Rimboard See pages 15 and 34.

For load bearing cantilever details, see page 19.

See also Intermediate Bearing details, page 16

When installing Boise Cascade EWP products with treated wood, use only connectors/fasteners that are approved for use with the corresponding wood treatment.

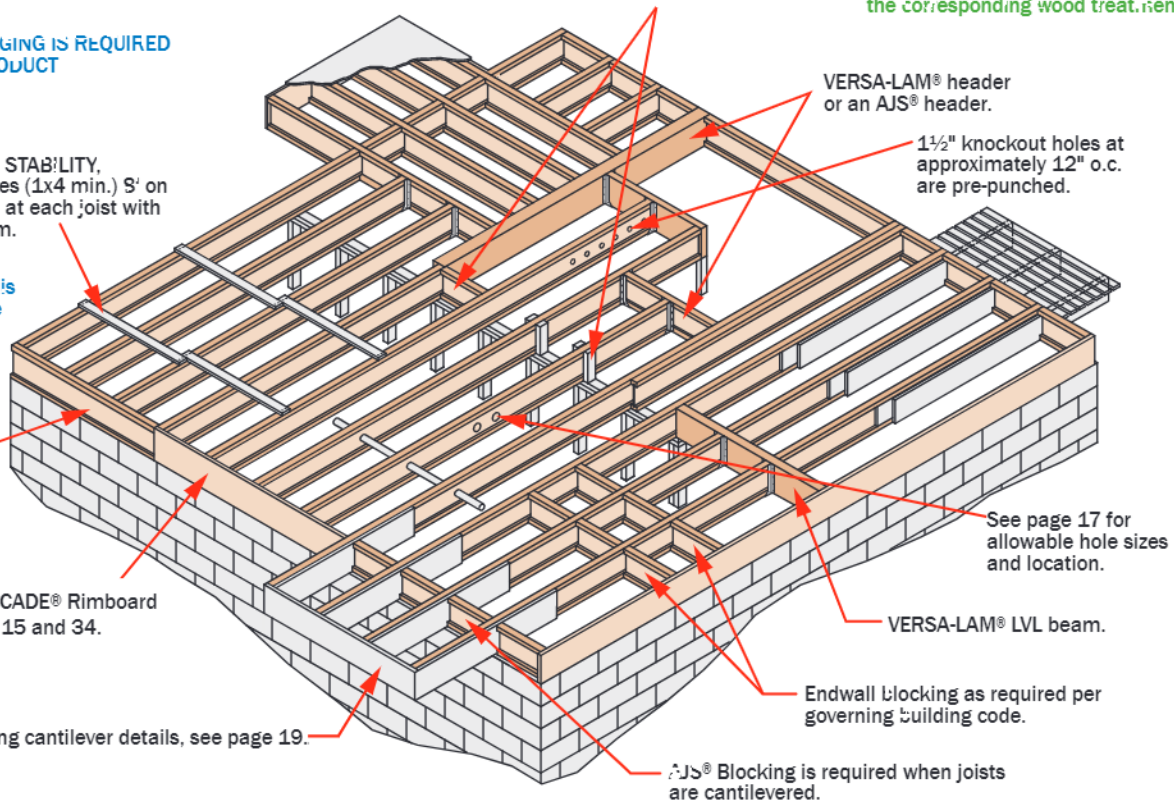

BCI® Joists, VERSA-LAM® and ALLJOIST® must be stored, installed and used in accordance with the Boise Cascade EWP Installation Guide, building codes, and to the extent not in conflict with the Boise Cascade EWP Installation Guide, local and customary building practices and standards. VERSA-LAM®, ALLJOIST®, and BCI® Joists must be wrapped, covered, and stored off of the ground on stickers at all times prior to installation. VERSA-LAM®, ALLJOIST® and BCI® Joists are intended only for applications

that assure no exposure to weather or the elements and an environment that is free from moisture from any source, or any pest, organism or substance which degrades or damages wood or glue bonds. Failure to correctly store, use or install VERSA-LAM®, ALLJOIST®, and BCI® Joist in accordance with the Boise Cascade EWP Installation Guide will void the limited warranty.

SAFETY WARNING

DO NOT ALLOW WORKERS ON AJS® JOISTS UNTIL ALL HANGERS, AJS® RIM JOISTS, RIM BOARDS, AJS® BLOCKING PANELS, X-BRACING AND TEMPORARY 1x4 STRUT LINES ARE INSTALLED AS SPECIFIED BELOW. SERIOUS ACCIDENTS CAN RESULT FROM INSUFFICIENT ATTENTION TO PROPER BRACING DURING CONSTRUCTION. ACCIDENTS CAN BE AVOIDED UNDER NORMAL CONDITIONS BY FOLLOWING THESE GUIDELINES:

- Build a braced end wall at the end of the bay, or permanently install the first eight feet of AJS® Joist and the first course of sheathing. As an alternate, temporary sheathing may be nailed to the first four feet of AJS® Joist at the end of the bay.
- All hangers, AJS® rim joists, rim boards, AJS® blocking panels, and x-bracing must be completely installed and properly nailed as each AJS® Joist is set.
- Install temporary 1x4 strut lines at no more than eight feet on center as additional AJS® Joists are set. Nail the strut lines to the sheathed area, or braced end wall, and to each AJS® Joist with two 8d nails.
- The ends of cantilevers must be temporarily secured by strut lines on both the top and bottom flanges.
- Straighten the AJS® Joist to within 1/2 inch of true alignment before attaching strut lines and sheathing.
- Remove the temporary strut lines only as required to install the permanent sheathing.
- Failure to install temporary bracing may result in sideways buckling or roll over under light construction loads.
- Do not stack construction materials (sheathing, drywall, etc) in the middle of AJS® Joist spans, contact Boise Cascade EWP Engineering for proper storage and shoring information.

PRODUCT HANDLING TO AND AT JOB SITES

There are some differences between engineered wood products and traditional lumber products in terms of product handling: AJS® joists are significantly weaker in the flat orientation. VERSA-LAM® is denser and due to the coating applied to the surface, can be more apt to sliding. Please consider these differences when transporting and handling engineered wood products.



Additional floor framing details available with BC FRAMER® software

END BEARING DETAILS

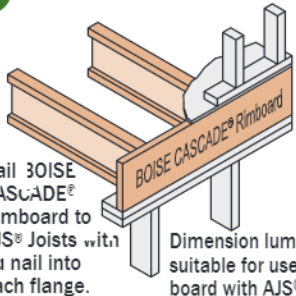
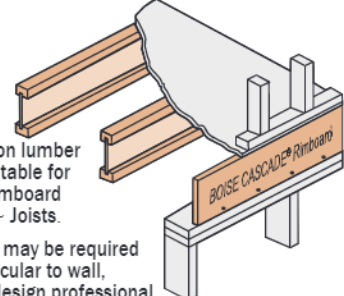
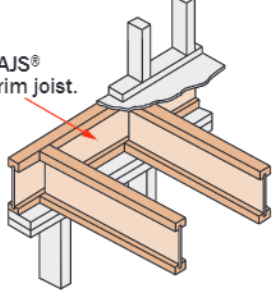
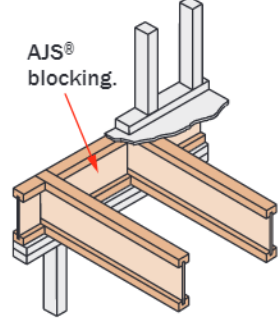
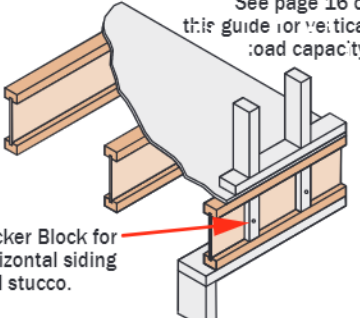
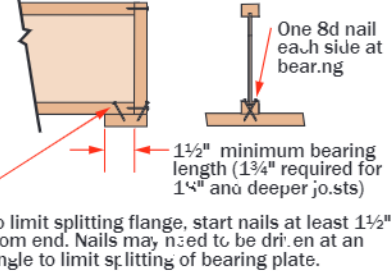
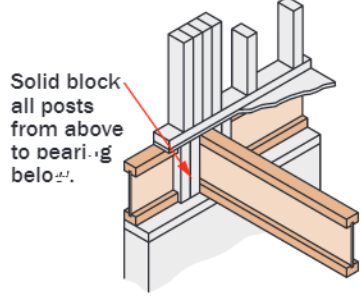
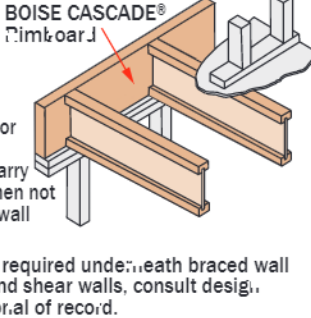
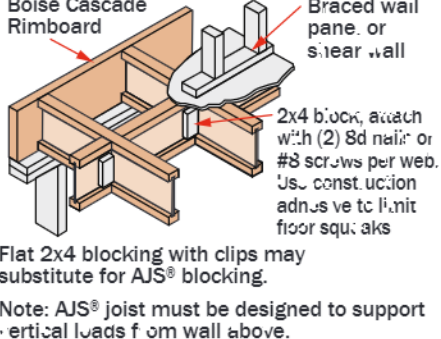
<p>F07</p>  <p>Nail JOISE CASCADE Rimboard to AJS Joists with 8u nail into each flange.</p> <p>Dimension lumber is not suitable for use as rim board with AJS Joists.</p>	<p>F07A</p>  <p>Dimension lumber is not suitable for use as rim board with AJS Joists.</p> <p>Blocking may be required perpendicular to wall, consult design professional of record and/or local building official.</p>	<p>F02</p>  <p>AJS rim joist.</p> <p>Use of AJS rimjoist requires 2x6 wall for minimum joist bearing.</p>
<p>F01</p>  <p>AJS blocking.</p>	<p>F18</p>  <p>See page 16 of this guide for vertical load capacity.</p> <p>Backer Block for horizontal siding and stucco.</p>	<p>F52</p>  <p>One 8d nail each side at bearing.</p> <p>1 1/2" minimum bearing length (1 3/4" required for 1 1/2" and deeper joists)</p> <p>To limit splitting flange, start nails at least 1 1/2" from end. Nails may need to be driven at an angle to limit splitting of bearing plate.</p>
<p>F08</p>  <p>Solid block all posts from above to bearing below.</p>	<p>F03</p>  <p>JOISE CASCADE Rimboard</p> <p>Note: AJS floor joist must be designed to carry wall above when not stacked over wall below.</p> <p>Blocking required underneath braced wall panels and shear walls, consult design professional of record.</p>	<p>F52</p>  <p>Boise Cascade Rimboard</p> <p>Braced wall panel or shear wall</p> <p>2x4 block, attach with (2) 8d nails or #8 screws per web. Use construction adhesives to limit floor squeaks.</p> <p>Flat 2x4 blocking with clips may substitute for AJS blocking.</p> <p>Note: AJS joist must be designed to support vertical loads from wall above.</p>

LATERAL SUPPORT

- AJS Joists must be laterally supported at end supports (including supports adjacent to overhangs) with hangers, rim board, or blocking (VERSA-LAM®, BOISE CASCADE® Rimboard or AJS® Joist). Metal cross bracing or other x-bracing provides adequate lateral support for AJS Joists. Consult governing building code for floor diaphragm connection provisions.
- Blocking may be required at intermediate bearings for floor diaphragm per project's structural engineer of record.

MINIMUM BEARING LENGTH FOR AJS® JOISTS

- Minimum end bearing: 1 1/2" for 9 1/2" - 16" deep joists, 1 3/4" for 18" and deeper joists. 3 1/2" minimum bearing length at cantilever and intermediate supports.
- Longer bearing lengths allow higher reaction values. Refer to the building code evaluation report or the BC CALC® software.

NAILING REQUIREMENTS

- AJS rim joist, rim board or closure panel to AJS joist:
 - Rims or closure panel 1 1/4 inches thick and deep: 2-8d nails, one each in the top and bottom flange.
 - AJS 20/190 rim joist: 2 16d box nails, one each in the top and bottom flange.
 - AJS 20/30 rim joist: Toe-nail top flange to rim joist with 2-10d box nails, one each side of flange.

- AJS rim joist, rim board or AJS blocking panel to support.
 - Min. 8d nails @ 6" o.c. per IBC.
 - Connection per design professional of record's specification for shear transfer.
- AJS joist to support:
 - 2-8d nails, one on each side of the web, placed 1 1/2 inches minimum from the end of the AJS joist to limit splitting.
- Sheathing to AJS joist:
 - Minimum nailing schedule 8d common nails @ 6" o.c. on edges and 12" o.c. in the field, see IBC table 2304.9.1 for other fastener options.
 - See closest allowable nail spacing limits on page 24 for floor diaphragm nailing specified at closer spacing than IBC.
 - Maximum bracing spacing for full lateral stability: 18" for AJS 190 & 20, 24" for larger AJS joist series.
 - 14 gauge staples may be substituted for 8d nails if the staples penetrate at least 1 inch into the joist.
 - Wood screws may be acceptable, contact local building official and/or Boise Cascade EWP Engineering for further information.

Additional floor framing details available with BC FRAMER® software

INTERMEDIATE BEARING DETAILS

F06

For load bearing wall above (stacked over wall below).

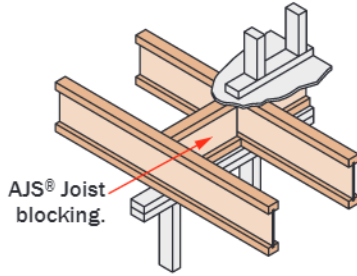

F09

Blocking may be required, consult design professional of record and/or local building official.

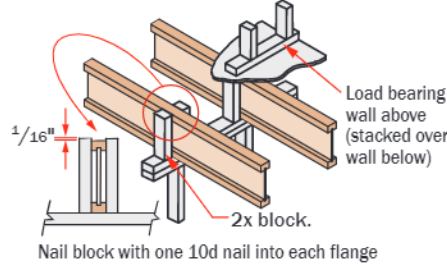

F28

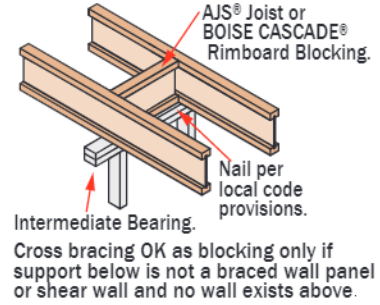

F05

Sheathing or rimboard closure

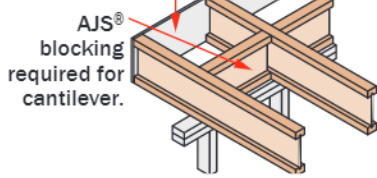

For load bearing cantilever, see page 19. Uplift on backspan shall be considered in all cantilever designs

F27A

Top Flange or Face Mount Joist Hanger

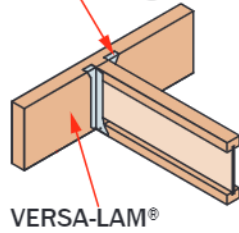

VERSA-LAM®

F14

AJS® Joist Slope Cut Reinforcement

Detail below restores original allowable shear/reaction value to cut end of AJS® joist. AJS® joist shall not be used as a collar or rafter tension tie.

2 x 6 min. rafter. Rafter shall be supported by ridge beam or other upper bearing support

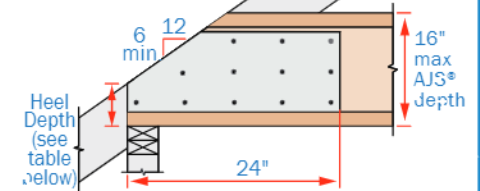

2x blocking required at bearing (not shown for clarity). 2x 4 min. plywood/OSB rated sheathing reinforcement. Install reinforcement with face grain horizontal parallel on both sides of the joist tight to bottom flange. 1/4" gap between reinforcement and bottom or top flange. Apply construction adhesive to contact surfaces and fasten with 3 rows of min. 10d box nails at 3" o.c. Alternate nailing from each side and clinch.

End Wall Bearing	Minimum Heel Depth					
	6/12	7/12	8/12	9/12	10/12	12/12
2 x 4	4 3/8"	4 5/8"	4 1/4"	4 3/4"	4 1/4"	4 1/4"
2 x 6	5 3/4"	3 3/4"	2 3/4"	2 3/4"	2 1/8"	2 1/4"

AJS® Joist Framing Flush to beam bottom edge.

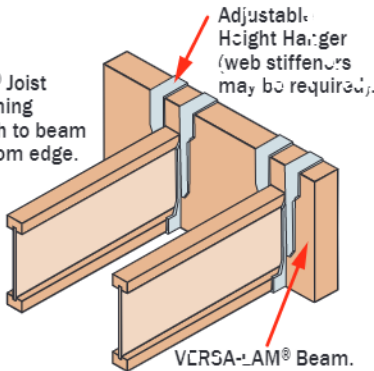

VERSA-LAM® Beam.

Connector strap nailing schedule shall adhere to AJS® closest nailing spacing provisions

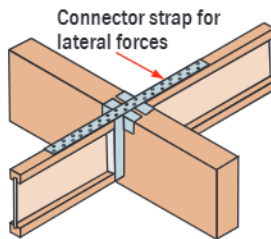

See connector manufacturer's code evaluation reports and literature for allowable loading. Axial force in top flange shall be considered in AJS® joist design.

BACKER AND FILLER BLOCK DIMENSIONS

Series	Backer Block Thickness	Filler Block Thickness
190 20	1 3/8" o. tw. 1/2" wood panels	2x_ + 5/8" wood panel
25 30	2x_ lumber	Double 2x_ lumber

- Cut backer and filler blocks to a maximum depth equal to the web depth minus 1/4" to avoid a forced fit.
- For deeper AJS® Joists, stack 2x lumber or use multiple pieces of 3/4" wood panels.

WEB STIFFENER REQUIREMENTS

- See *Web Stiffener Requirements* on page 19.

PROTECT AJS® JOISTS FROM THE WEATHER

- AJS® Joists are intended only for applications that provide permanent protection from the weather. Bundles of product should be covered and stored off of the ground on stickers.

AJS® RIM JOISTS AND BLOCKING

Joist Depth	Vertical Load Transfer Capacity (plf)
9 1/2"	1875
11 7/8"	1680
14"	1500
16"	1340
18" & 20" (1)	3200
22" & 24" (1)	2700

1) Web stiffeners required at each end of blocking panel. Distance between stiffeners must be less than 24".

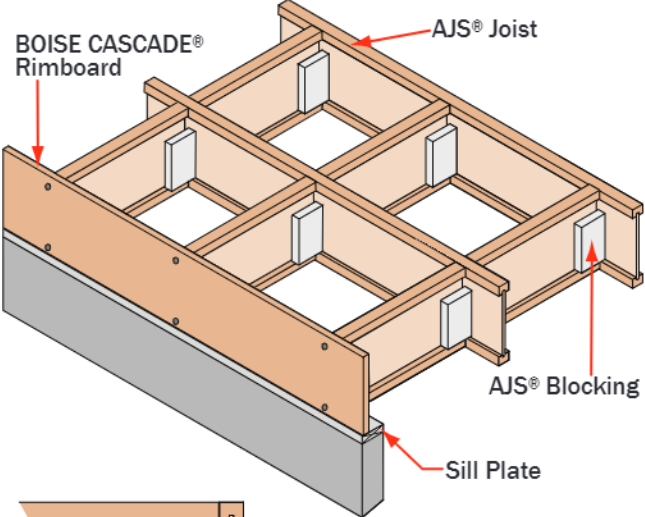
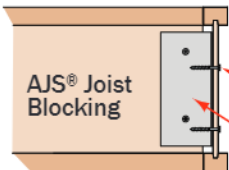
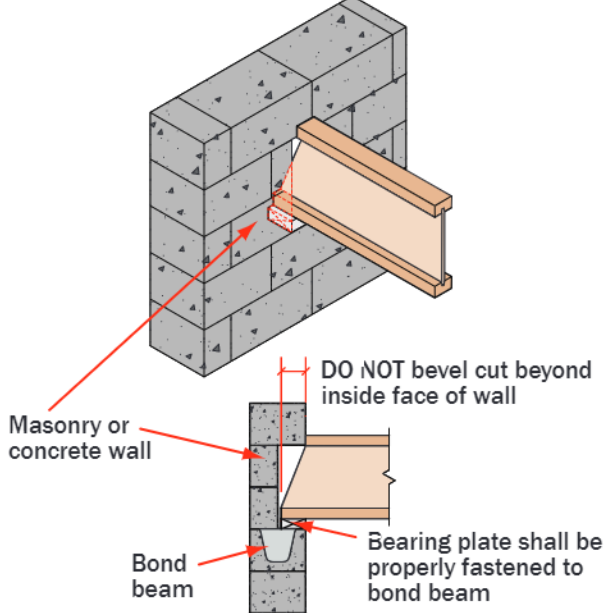
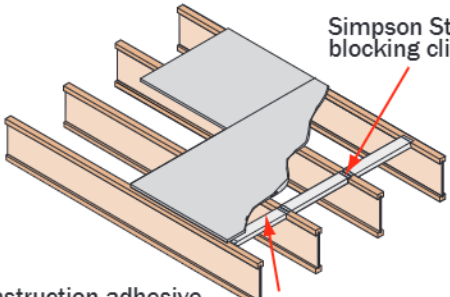
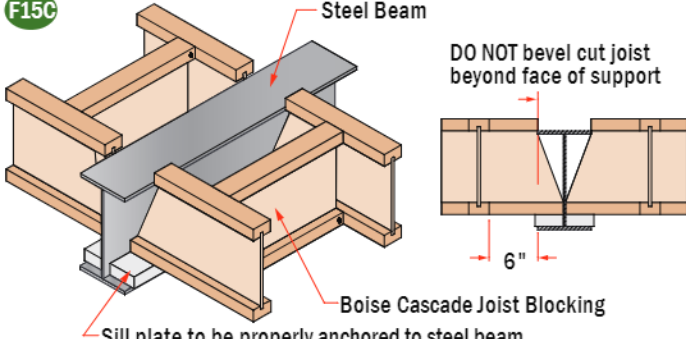
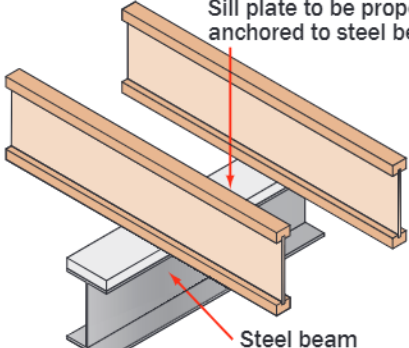
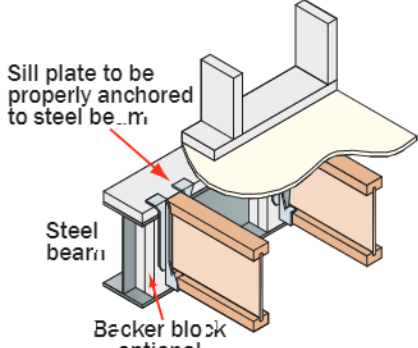
Floor Bracing for Endwall	AJS® Joist Fire Cut
<p>Block spacing per governing code and diaphragm nailing per engineer of record. Intent of blocking is to resist external lateral forces acting perpendicular to wall.</p>  <p>BOISE CASCADE® Rimboard</p> <p>AJS® Joist</p> <p>AJS® Blocking</p> <p>Sill Plate</p>  <p>AJS® Joist Blocking</p> <p>(2) 8d nails or #8 wood screws per web</p> <p>2x4 lumber</p> <p>Apply construction adhesive to contact surfaces to limit floor squeaks.</p>	 <p>Masonry or concrete wall</p> <p>Bond beam</p> <p>Bearing plate shall be properly fastened to bond beam</p> <p>DO NOT bevel cut beyond inside face of wall</p> <ol style="list-style-type: none"> 1) Joists shall be restrained from rotation at end bearing by installing blocking panels or cross-bridging between joists (not shown for clarity). 2) Joists shall not be in direct contact with masonry or concrete. A minimum of 1/2" of air space or an adequate moisture barrier shall be provided between joists and wall pocket. 3) Joists are to be installed in dry use conditions only.
Blocked Diaphragm Nailing Detail	Connection on Steel Beam Bottom Flange
 <p>Simpson Strong-Tie Z2 blocking clip</p> <p>Flat 2x4's at panel edges for diaphragm nailing</p> <p>Apply construction adhesive to contact surfaces to limit floor squeaks.</p>	<p>F15C</p>  <p>Steel Beam</p> <p>Boise Cascade Joist Blocking</p> <p>Sill plate to be properly anchored to steel beam</p> <p>DO NOT bevel cut joist beyond face of support</p> <p>6"</p>
Connection on Steel Beam	Connection on Hanger with Steel Beam
<p>F15D</p>  <p>Sill plate to be properly anchored to steel beam</p> <p>Steel beam</p>	<p>F15E</p>  <p>Sill plate to be properly anchored to steel beam</p> <p>Steel beam</p> <p>Becker block optional</p>

Filler Block Connection Specifications

Filler block connections are to be used in applications where the joists are not loaded evenly. Filler block connections shall be used for uniform and concentrated side load conditions. Top load conditions where the load is not centered or evenly distributed shall be evaluated by the project design professional of record (flange nailing is structurally adequate for non-load bearing partition walls).

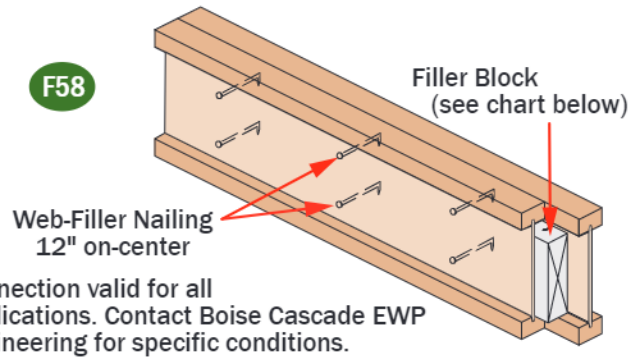

AJS® Series	Depth	Filler Block	Nailing Pattern
140, 150, 20, 190	9½", 11⅞", 14", 16"	2x lumber + ⅝" wood panel	2 rows 10d nails @ 12" o.c., staggered & clinched
25, 30	11⅞", 14", 16"	Double 2x lumber	2 rows 10d nails @ 12" o.c., staggered, nailed from both sides
25, 30	18", 20"	Double 2x lumber	2 rows 10d nails @ 12" o.c., staggered, nailed from both sides
25, 30	22", 24"	Double 2x lumber	4 rows 10d nails @ 12" o.c., staggered, nailed from both sides

Notes

- Filler block is required between AJS® joists for the full length of span to resist uniform side loads, 24" minimum at concentrated side loads. Filler blocks do not need to be continuous.
- Filler block to be installed tight to bottom flange. Specified filler block material may leave gap between top of block and bottom of top flange. If receiving joists from face mount joist hangers, this gap must be filled to within 1/8" of top flange. The same filler block material may

be stacked to fill the gap. Provide one row of 10d nails @ 12" o.c., staggered & clinched for stacked web-filler nailing in addition to nailing shown.

- Triple Members Nail first two joists as shown, then attach third with same filler and nailing.
- Nail sheathing to all joists per diaphragm nailing schedule.

Concentrated Load Connections

Concentrated Side Loads

The following detail shows the proper connection of concentrated side loads to single and multiple AJS® members:

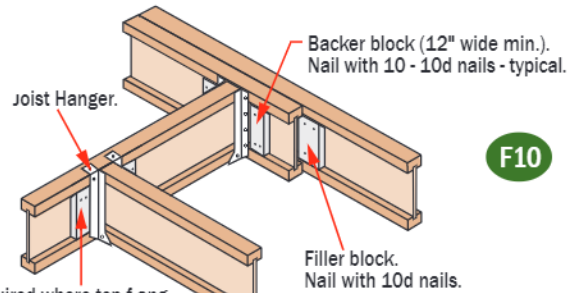

Backer block required where top flange joist hanger load exceeds 250 lbs. Install tight to top flange, or to joist hanger's tight to bottom flange for face mount hangers. Refer to hanger literature for possible reductions in hanger capacity due to a joist header.

TOP FLANGE HANGER	FACE MOUNT HANGER Single AJS® Header (typical)	FACE MOUNT HANGER Double AJS® Header (typical)
<p>Hold block tight to underside of top flange.</p> <p>Backer Block. (Backer block nails not show for clarity)</p> <p>TOP FLANGE HANGER Hanger Max Load = 750 lb (250 lb w/o Backer Block)</p>	<p>1/4" gap - typical @ face mount conditions.</p> <p>10-10d @ ea. backer block - typical.</p> <p>Backer Block each side.</p> <p>FACE MOUNT Single AJS® Header (typical) Hanger Max Load = 1500 lb</p>	<p>10-10d @ ea. backer block - typical.</p> <p>Stacked Filler Block, as req'd. (Refer to Filler Block Notes)</p> <p>Filler Block. (Nails not shown for clarity)</p> <p>Backer Block. (Backer block nails not show for clarity)</p> <p>FACE MOUNT Double AJS® Header (typical) Hanger Max Load = 2500 lb</p>

Notes:

- Use filler block thickness for corresponding AJS® series as specified in filler block connection table, page 3. For single concentrated side loads, minimum filler block length is 24" long with 6-10d connecting nails.
- Nail sheathing to all joists per diaphragm nailing schedule.
- Refer to hanger manufacturer literature for reductions in hanger capacity due to I-joist headers.
- Max loads shown are for connections only. The structural adequacy of all headers, beams, girders and hangers to be determined by the design professional of record.
- All backer blocks to be nailed with 10-10d nails.
- All nails protruding more than 1/4" to be clinched.

AJS® Header Blocking at Side Loaded Conditions

Required for triple members, recommended best practices for double members.

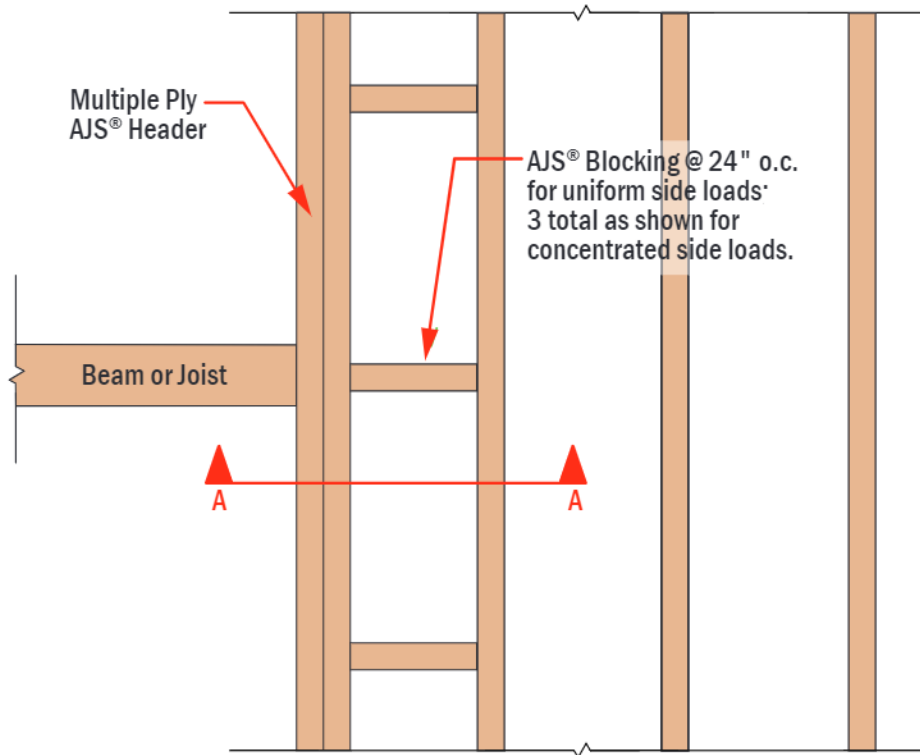

Plan

NOTE: Nail floor sheathing to all joists, blocking and headers per diaphragm nailing schedule.

AJS® Blocking @ end blocks. Fasten blocks with (2) 8d nails or 2 1/2" screws (typical)

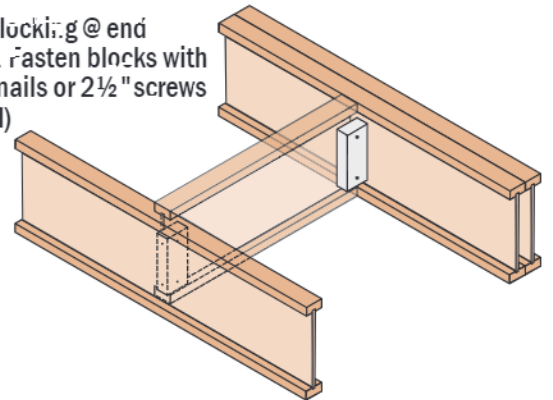

Attach floor panel to each blocking panel with (3) 8d nails, minimum.

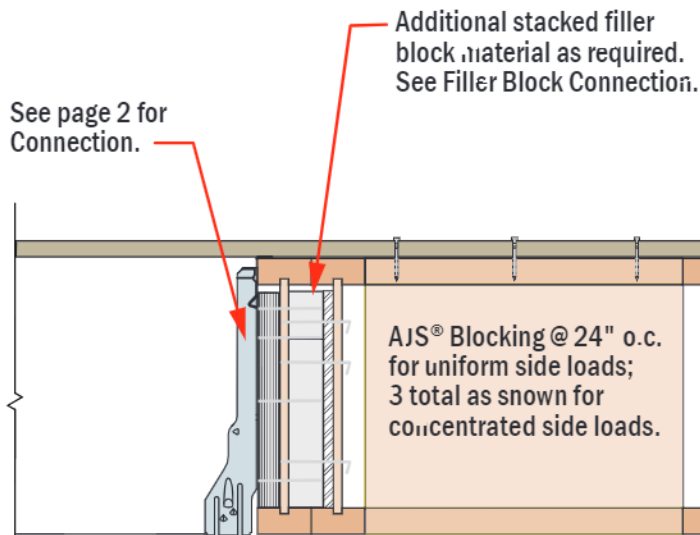

Section A-A

AJS® Joist Hole Location & Sizing

AJS® Joists are manufactured with 1 1/2" round perforated knockouts in the web at approximately 12" on center

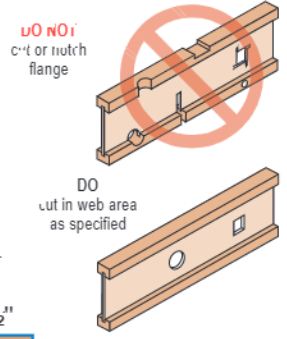
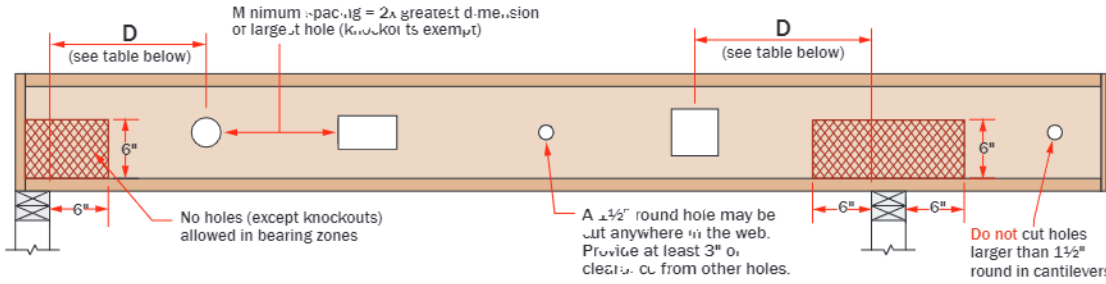

Minimum distance from support, listed in table below, is required for all holes greater than 1 1/2"

MINIMUM DISTANCE (D) FROM ANY SUPPORT TO THE CENTERLINE OF THE HOLE																
Round Hole Diameter [in]	2	3	4	5	6	6 1/2	7	8	8 3/4	9	10	11	12	13		
Rectangular Hole Side [in]	-	-	2	4	6	6	-	-	-	-	-	-	-	-		
Any 3/4" Joist	Span [ft]	8	2'-0"	2'-5"	3'-11"	3'-5"	3'-10"	4'-0"								
	12	3'-0"	3'-8"	4'-5"	5'-1"	5'-10"	6'-0"									
	16	4'-0"	4'-11"	5'-11"	6'-10"	7'-9"	8'-0"									
Round Hole Diameter [in]	2	3	4	5	6	6 1/2	7	8	8 3/4	9	10	11	12	13		
Rectangular Hole Side [in]	-	-	-	2	3	4	5	7	8							
Any 1 1/8" Joist	Span [ft]	8	1'-0"	1'-5"	1'-10"	2'-3"	2'-8"	2'-11"	3'-1"	3'-6"	3'-11"					
	12	1'-5"	2'-1"	2'-9"	3'-5"	4'-0"	4'-4"	4'-8"	5'-4"	5'-11"						
	16	1'-11"	2'-10"	3'-8"	4'-6"	5'-5"	5'-10"	6'-8"	7'-1"	7'-10"						
	20	2'-5"	3'-6"	4'-7"	5'-8"	6'-9"	7'-3"	7'-10"	8'-11"	9'-10"						
Round Hole Diameter [in]	2	3	4	5	6	6 1/2	7	8	8 3/4	9	10	11	12	13		
Rectangular Hole Side [in]	-	-	-	-	2	3	3	5	6	8	8	9	-	-		
Any 1 1/4" Joist	Span [ft]	8	1'-0"	1'-1"	1'-2"	1'-4"	1'-8"	1'-11"	2'-1"	2'-8"	2'-10"	2'-11"	3'-4"	3'-9"		
	12	1'-8"	1'-1"	1'-4"	2'-3"	2'-7"	2'-11"	3'-2"	3'-10"	4'-4"	4'-5"	5'-0"	5'-7"			
	16	1'-11"	1'-1"	1'-10"	2'-8"	3'-5"	3'-10"	4'-3"	5'-1"	5'-9"	5'-11"	6'-8"	7'-4"			
	20	1'-0"	1'-8"	2'-4"	3'-1"	4'-4"	4'-13"	5'-4"	6'-4"	7'-8"	7'-4"	8'-5"	9'-5"			
	24	1'-8"	1'-7"	2'-9"	4'-0"	5'-2"	5'-10"	6'-5"	7'-8"	8'-8"	8'-10"	10'-1"	11'-3"			
Round Hole Diameter [in]	2	3	4	5	6	6 1/2	7	8	8 3/4	9	10	11	12	13		
Rectangular Hole Side [in]	-	-	-	-	-	-	2	3	5	5	6	8	9	13		
Any 1 1/2" Joist	Span [ft]	8	1'-8"	1'-1"	1'-2"	1'-2"	1'-3"	1'-3"	1'-3"	1'-8"	2'-0"	2'-1"	2'-5"	2'-10"	3'-2"	3'-7"
	12	1'-11"	1'-1"	1'-2"	1'-2"	1'-4"	1'-8"	1'-11"	2'-5"	3'-0"	3'-1"	3'-8"	4'-3"	4'-10"	5'-5"	
	16	1'-0"	1'-1"	1'-2"	1'-2"	1'-10"	2'-2"	2'-7"	3'-4"	4'-0"	4'-2"	4'-11"	5'-8"	6'-5"	7'-2"	
	20	1'-8"	1'-1"	1'-2"	1'-4"	2'-3"	2'-9"	3'-3"	4'-3"	5'-1"	5'-2"	6'-2"	7'-1"	8'-1"	9'-8"	
	24	1'-11"	1'-1"	1'-2"	1'-7"	2'-9"	3'-4"	3'-11"	5'-1"	6'-1"	6'-3"	7'-4"	8'-11"	9'-8"	10'-10"	

- Select a table row based on joist depth and the actual joist span rounded up to the nearest table span. Scan across the row to the column headed by the appropriate round hole diameter or rectangular hole side. Use the longest side of a rectangular hole. The table value is the closest that the centerline of the hole may be to the centerline of the nearest support.
- The entire web may be cut out. **DO NOT** cut the flanges. Holes apply to either single or multiple joists in repetitive member conditions.
- For multiple holes, the amount of uncut web between holes must equal at least twice the diameter (or longest side) of the largest hole.
- 1 1/2" round knockout: in the web may be removed by using a short piece of metal pipe and hammer.
- Holes may be positioned vertically anywhere in the web. The joist may be set with the 1 1/2" knockout holes turned either up or down.
- This table was designed to apply to the design conditions covered by tables elsewhere in this publication. Use the BC CALC® software to check other hole sizes or holes under other design conditions. It may be possible to exceed the limitations of this table by analyzing a specific application with the BC CALC® software.

Large Rectangular Holes in AJS® Joists

Hole size table based on maximum uniform load of 40 psf live load and 25 psf dead load, at maximum spacing of 24" on-center.

Single Span Joist

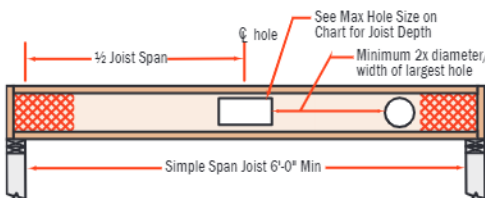

Joist Depth	Maximum Hole Size	
	Simple Span	Multiple Span
9 1/2"	6" x 12"	6" x 7"
11 3/8"	8" x 13"	8" x 8"
14"	9" x 16"	10" x 13"
	10" x 14"	9" x 11"
17"	11" x 16"	10" x 14"
	12" x 15"	11" x 12"

Multiple Span Joist

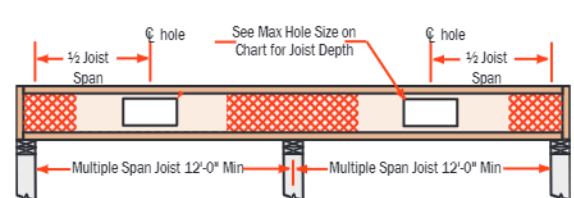

Larger holes may be possible for either Single or Multiple span joists, use BC CALC® sizing software for specific analysis.

Note: Additional holes may be cut in the web provided they meet the specifications as shown in the hole distance chart shown above or as allowed using BC CALC® sizing software.

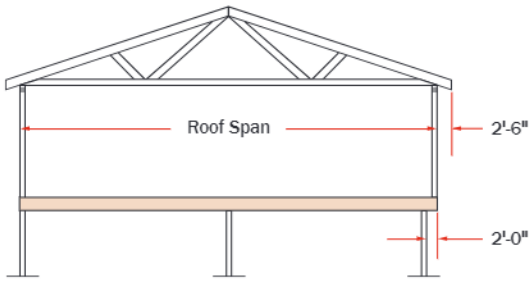

The detail to the right on this page shows the installation of cantilever reinforcement for load-bearing cantilevers up to a maximum length of 2'-0". Cantilevers longer than 2'-0" cannot be reinforced. **However, longer cantilevers with lower loads may be allowed without reinforcement. Analyze specific applications with the BC CALC® software.**

PLYWOOD / OSB REINFORCEMENT (If Required per BC CALC® analysis)

Analyze AJS® Load Bearing Cantilevers in BC CALC® Software

- 3/32" Min. x 48" long plywood / OSB rated sheathing must match the full depth of the AJS® Joist. Nail to the AJS® Joist with 8d nails at 3" o.c. and nail with 4-8d nails into backer block. When reinforcing both sides, stagger nails to limit splitting. Install with horizontal face grain.
- These requirements assume a 100 PLF wall load and apply to AJS® Joists. Additional support may be required for other loadings. See BC CALC® software.
- Contact Boise Cascade EWP Engineering for reinforcement requirements on AJS® Joist depths greater than 16"

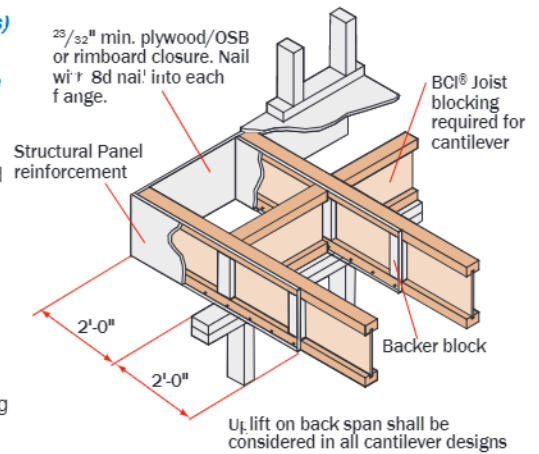

Non-Load Bearing Wall Cantilever Details

AJS® Joists are intended only for applications that provide permanent protection from the weather.

Fasten the 2x8 minimum to the AJS® Joist by nailing through the backer block and joist web with 2 rows of 10d nails at 6" on center. Clinch all nails.

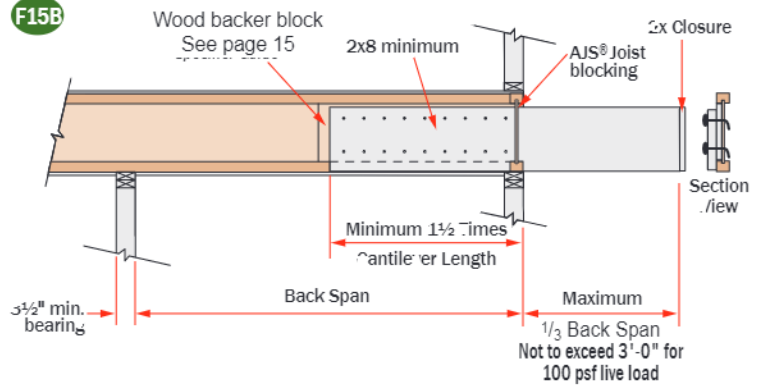
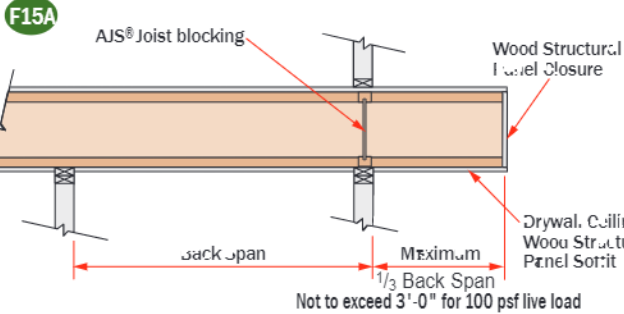

- These details apply to cantilevers with uniform loads only.
- It may be possible to exceed the limitations of these details by analyzing a specific application with the BC CALC® software.

Web Stiffener Requirements

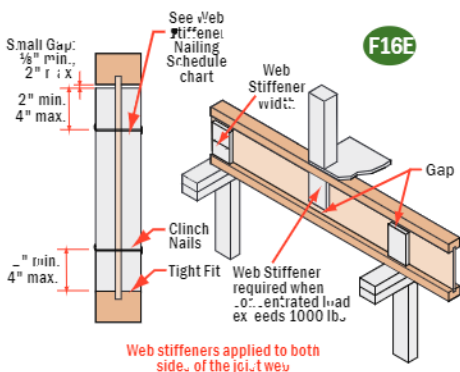

NOTES

- Web stiffeners are optional except as noted below.
- Web stiffeners are always required in hangers that do not extend up to support the top flange of the AJS® Joist. Web stiffeners may be required with certain sloped or skewer hangers or to achieve uplift values. Refer to the hanger manufacturer's installation requirements.
- Web stiffeners are always required in certain roof applications. See Roof Framing Details on page 24.
- Web stiffeners are always required under concentrated loads that exceed 1000 pounds. Install the web stiffeners snug to the top flange in this situation. Follow the nailing schedule for intermediate bearings.
- Web stiffeners may be cut from structural rated wood panels, engineered rimboard or 2x lumber (AJS® 25 and 30 series only).
- For Structural Capacity: Web stiffeners needed to increase the AJS® Joist's reaction capacity at a specific bearing location.
- Lateral Restraint in Hanger: Web stiffeners required when hanger does not laterally support the top flange (e.g., adjustable height hangers). Web stiffeners may be of multiple thickness (e.g., AJS® 20 / 190 double 1/2" panel OK).
- Web stiffeners may be used to increase allowable reaction values. See AJS® Design Properties on page 24 or the BC CALC® software.

Web Stiffener Nailing Schedule

AJS® Joist Series	Joist Depth	Nailing
20	9 1/2" – 11 7/8"	3-10d
190	14" – 16"	5-10d
25		
25	16" – 24"	5-10d
30		

Structural Panel Web Stiffener

AJS® Series	Minimum Thickness		Minimum width
	In Hanger	No Hanger	
20 / 190	1"	1 1/2"	2 3/4"
25 / 30	2x4 lumber (vertical)		

Allowable Uniform Floor Load (in pounds per lineal foot [PLF])

100% Load Duration

Span Length	AJS® 20 Series 2½" Flange Width								AJS® 190 Series 2½" Flange Width							
	9½" AJS® 20		11⅞" AJS® 20		14" AJS® 20		16" AJS® 20		9½" AJS® 190		11⅞" AJS® 190		14" AJS® 190		16" AJS® 190	
	Live Load	Total Load	Live Load	Total Load	Live Load	Total Load	Live Load	Total Load	Live Load	Total Load	Live Load	Total Load	Live Load	Total Load	Live Load	Total Load
8	-	313	-	318	-	320	-	323	-	313	-	318	-	320	-	323
9	-	268	-	272	-	274	-	277	-	268	-	272	-	274	-	277
10	-	235	-	238	-	240	-	242	-	235	-	238	-	240	-	242
11	-	208	-	212	-	215	-	215	-	208	-	212	-	213	-	215
12	-	188	-	191	-	192	-	194	-	188	-	191	-	192	-	194
13	161	170	-	173	-	174	-	176	168	170	-	173	-	174	-	176
14	128	156	-	159	-	160	-	161	133	153	-	159	-	160	-	161
15	102	144	-	146	-	147	-	149	107	144	-	146	-	147	-	149
16	80	134	-	136	-	137	-	139	87	134	-	136	-	137	-	138
17	69	120	113	127	-	129	-	129	72	125	118	127	-	128	-	129
18	57	106	95	119	-	120	-	121	60	117	99	119	-	120	-	121
19	48	93	80	112	-	112	-	114	50	101	83	112	-	112	-	114
20	41	82	68	106	98	106	-	107	43	80	71	106	102	103	-	107
21			58	97	84	101	-	102			61	100	88	101	-	102
22			50	88	73	96	-	97			53	95	76	96	-	97
23			44	79	63	91	85	92			46	90	66	91	89	92
24					55	87	74	88			40	80	58	87	78	88
25					49	80	65	84					51	83	69	84
26					43	73	58	80					45	80	61	80
27							51	77					40	76	54	77
28							46	72							48	74
29							41	67							43	71
30																
31																
32																
33																
34																
35																
36																
37																
38																
39																
40																

- Total Load values are limited by shear, moment, or deflection equal to $L/40$.
- Live Load values are limited by deflection equal to $L/480$. For deflection limits of $L/360$ and $L/960$, multiply the Live Load values by 1.33 and 0.50 respectively.
- Both the Total Load and Live Load columns must be checked. Where a Live Load value is not shown, the Total Load value will control.
- Table values apply to either simple or multiple span joists. Span is measured center to center of the minimum required bearing length. Analyze multiple span joists with the BC CALC® software if the length of any span is less than half the length of an adjacent span.
- Table values do not consider composite action from gluing and nailing floor sheathing (composite action is considered in floor span tables on page 4).
- Total Load values assume minimum bearing lengths without web stiffeners for joist depths of 16 inches and less.
- For assistance with floor design, consult the section *About Floor Performance* on page 4.
- This table was designed to apply to a broad range of applications. It may be possible to exceed the limitations of this table by analyzing a specific application with the BC CALC® software.

Allowable Uniform Floor Load (in pounds per lineal foot [PLF])

100% Load Duration

Span Length	AJS® 25 Series 3½" Flange Width															
	9½" AJS® 25		11⅞" AJS® 25		14" AJS® 25		16" AJS® 25		18" AJS® 25		20" AJS® 25		22" AJS® 25		24" AJS® 25	
	Live Load	Total Load	Live Load	Total Load	Live Load	Total Load	Live Load	Total Load	Live Load	Total Load	Live Load	Total Load	Live Load	Total Load	Live Load	Total Load
6	-	316	-	318	-	320	-	323	-	629	-	681	-	697	-	712
7	-	271	-	272	-	274	-	277	-	539	-	584	-	597	-	610
8	-	237	-	238	-	240	-	242	-	472	-	511	-	523	-	534
9	-	211	-	212	-	213	-	215	-	419	-	454	-	464	-	475
10	-	190	-	191	-	192	-	194	-	377	-	408	-	418	-	427
11	-	172	-	173	-	174	-	176	-	343	-	371	-	380	-	388
12	-	158	-	159	-	160	-	161	-	314	-	340	-	348	-	356
13	136	146	-	146	-	147	-	149	-	290	-	314	-	321	-	328
14	111	135	-	136	-	137	-	138	-	269	-	292	-	298	-	305
15	92	126	-	127	-	128	-	129	-	251	-	272	-	278	-	285
16	77	118	-	119	-	120	-	121	-	236	-	255	-	261	-	267
17	65	111	107	112	-	112	-	114	-	222	-	240	-	246	-	251
18	55	105	91	106	-	106	-	107	-	209	-	227	-	232	-	237
19	47	95	78	100	-	101	-	102	197	198	-	215	-	220	-	225
20	41	82	68	95	-	96	-	97	171	188	-	204	-	209	-	213
21			59	90	85	91	-	92	150	179	187	194	-	199	-	203
22			52	86	74	87	-	88	132	171	165	185	-	190	-	194
23			46	83	66	83	-	84	116	164	146	177	178	181	-	185
24			40	79	58	80	78	80	103	152	129	170	158	174	-	178
25					52	76	69	77	92	140	115	157	141	167	170	171
26					46	73	62	74	82	129	103	145	127	159	153	164
27					41	71	56	71	74	120	93	134	114	147	137	158
28							50	69	66	111	84	125	103	137	124	149
29							45	66	60	104	76	116	93	127	112	139
30							41	64	54	97	69	109	84	119	102	130



Allowable Uniform Floor Load (in pounds per lineal foot [PLF])

100% Load Duration

Span Length	AJS® 30 Series 3½" Flange Width							
	18" AJS® 30		20" AJS® 30		22" AJS® 30		24" AJS® 30	
	Live Load	Total Load	Live Load	Total Load	Live Load	Total Load	Live Load	Total Load
10	-	377	-	408	-	418	-	427
11	-	343	-	371	-	380	-	388
12	-	314	-	340	-	348	-	356
13	-	290	-	314	-	321	-	328
14	-	269	-	292	-	298	-	305
15	-	251	-	272	-	278	-	285
16	-	236	-	255	-	261	-	267
17	-	222	-	240	-	246	-	251
18	-	209	-	227	-	232	-	237
19	-	198	-	215	-	220	-	225
20	186	188	-	204	-	209	-	213
21	163	179	-	194	-	199	-	203
22	144	171	179	185	-	190	-	194
23	127	164	159	177	-	181	-	185
24	113	157	141	170	172	174	-	178
25	100	151	126	163	154	167	-	171
26	90	145	113	157	138	160	-	164
27	81	139	101	151	124	154	149	158
28	73	134	92	146	112	149	135	152
29	66	130	83	140	102	144	122	147
30	60	120	75	136	92	139	111	142
32	50	100	62	121	77	130	93	133
34	42	84	52	105	65	117	78	125
36			44	89	55	105	66	114
38					47	94	57	102

AJS® Rafters

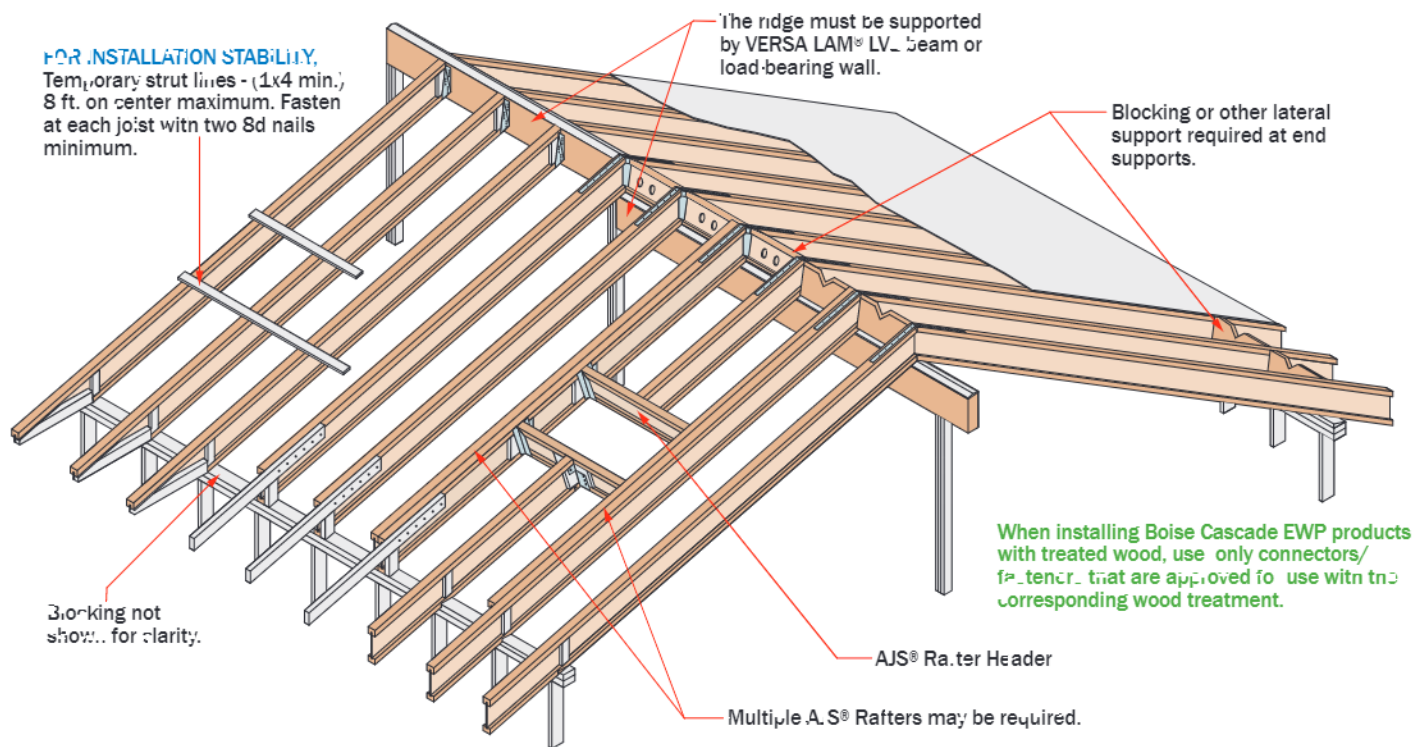

SAFETY WARNING

DO NOT ALLOW WORKERS ON AJS® JOISTS UNTIL ALL HANGERS, AJS® RIM JOISTS, RIM BOARDS, AJS® BLOCKING PANELS, X-BRACING AND TEMPORARY 1 X 4 STRUT LINES ARE INSTALLED AS SPECIFIED BELOW.

SERIOUS ACCIDENTS CAN RESULT FROM INSUFFICIENT ATTENTION TO PROPER BRACING DURING CONSTRUCTION. ACCIDENTS CAN BE AVOIDED UNDER NORMAL CONDITIONS BY FOLLOWING THESE GUIDELINES:

- Build a braced end wall at the end of the bay; or, permanently install the first eight feet of AJS® Joists and the first course of sheathing. As an alternate, temporary sheathing may be nailed to the first four feet of AJS® Joists at the end of the bay
- All hangers, AJS® rim joists, rim boards, AJS® blocking panels, and x-bracing must be completely installed and properly nailed as each AJS® Joist is set.
- Install temporary 1x4 strut lines at no more than eight feet on center as additional AJS® Joists are set. Nail the strut lines to the sheathed area, or braced end wall, and to each AJS® Joist with two 8d nails
- The ends of cantilevers must be temporarily secured by strut lines on both the top and bottom flanges.
- Straighten the AJS® Joist to within 1/2 inch of true alignment before attaching strut lines and sheathing
- Remove the temporary strut lines only as required to install the permanent sheathing.
- Failure to install temporary bracing may result in sideways buckling or roll-over under light construction loads.



Additional roof framing details available with BC FRAMER® software (see page 45)

R01

2x beveled plate for slope greater than 1/4/12.

Simpson VPA or USP TMP connectors or equal can be used in lieu of beveled plate for slopes from 3/12 to 12/12.

R02

Rimboard / VERSA-LAM® blocking. Ventilation "V" cut: 1/3 of length, 1/2 of depth.

2x4 blocking for soffit support.

2'-6" max.

Flange of AJS® Joists may be birdsmouth cut only at the low end of the joist. Birds-mouth cut AJS® joist must bear fully on plate. web stiffener required each side. Bottom flange shall be full supported.

R03

Rimboard / VERSA-LAM® blocking. Ventilation "V" cut: 1/3 of length, 1/2 of depth.

Tight fit for lateral stability.

2'-6" max.

Flange of AJS® Joists may be birdsmouth cut only at the low end of the joist. Birds-mouth cut AJS® joist must bear fully on plate. web stiffener required each side.

R04

10d nails at 6" o.c.

2x4 one side for 135 PLF max. 2x6 one side for 240 PLF max.

Backer block. Thickness per corresponding AJS® series.

2x block.

AJS® blocking. Holes cut for ventilation.

4'-0" horiz.

2'-6" horiz.

R05

Simpson or USP LSTA24 strap where slope exceeds 7/12 (straps may be required for lower slopes in high-wind areas). Nailing per governing building code.

AJS® Blocking: Row on each side of ridge or alternate. Holes cut for ventilation.

VERSA-LAM® LVL support beam.

Double-beveled plate, connect to ridge with 2 rows 16d nails at 12" o.c.

R06

Simpson LSSUI or USP TMU hanger.

VERSA-LAM® LVL support beam.

Beveled web stiffener on each side.

R07

Backer block (minimum 12" wide). Nail with 10-10d nails.

Joist Hanger.

Filler block. Nail with 10-10d nails.

Backer block required where top flange joist hanger load exceeds 250 lbs. Install tight to top flange.

R11

Double joist may be required when L exceeds rafter spacing.

Blocking as required.

Nail outrigger through AJS® web.

2" x outrigger notched around AJS® top flange. Outrigger spacing no greater than 24" on-center.

End Wall.

L (2'-0" max.)

LATERAL SUPPORT

- AJS® Joists must be laterally supported at end supports (including supports adjacent to overhangs) with hanger, rim board, or blocking (VERSA-LAM®, BOISE CASCADE® Rimboard or AJS® Joist). Metal cross bracing or other x-bracing provides adequate lateral support for AJS® Joists, consult governing building code for roof diaphragm connection provisions.
- Blocking may be required at intermediate bearings for roof diaphragm per project's structural engineer or record.

MINIMUM BEARING LENGTH FOR AJS® JOISTS

- Minimum end bearing: 1 1/2" for 9 1/2" - 16" deep joists, 1 3/4" for 18" and deeper joists. 3 1/2" minimum bearing length at cantilever and intermediate supports.
- Longer bearing lengths allow higher reaction values. Refer to the building code evaluation report or the BC CALC® software.

NAILING REQUIREMENTS

- AJS® rim joist, rim board or closure panel to AJS® joist:
 - Rims or closure panel 1/4 inches thick and less: 2-8d nails, one each in the top and bottom flange.
 - AJS® 190/20 rim joist: 2-16d box nails, one each in the top and bottom flange.
 - AJS® 25/30 rim joist: Toe-nail top flange to rim joist with 2 10d box nails, one each side of flange.
- AJS® rim joist, rim board or AJS® blocking panel to support:
 - Min. 8d nails @ 6" o.c. per IBC.
 - Connection per design professional of record's specification for shear transfer.

- AJS® joist to support:
 - 2-8d nails, one on each side of the web, placed 1 1/2 inches minimum from the end of the AJS® Joist to limit splitting.

- Sheathing to AJS® joist:
 - Minimum nailing schedule 8d common nails @ 6" o.c. on edges and 12" c.c. in the field, see IBC Table 2304.4.1 for other fastener options.
 - See closest allowable nail spacing limits on page 24 for floor diaphragm nailing specific: at closer spacing than IBC
 - Maximum bracing spacing for full lateral stability: 18" for AJS® 130 & 20, 24" for larger AJS® joist series.
 - 1 1/4 gauge staples may be substituted for 8d nails if the staples penetrate at least 1 inch into the joist.
 - Wood screws may be acceptable, contact local building official and/or Boise Cascade EWP Engineering for further information.

BACKER AND FILLER BLOCK DIMENSIONS

AJS® Series	Backer Block Thickness	Filler Block Thickness
190 20	1 1/8" or two 1/2" wood panels	2x _ + 5/8" wood panel
25 30	2x _ lumber	Double 2x _ lumber

- Cut backer and filler blocks to a maximum depth equal to the web depth minus 1/4" to avoid a forced fit.

WEB STIFFENER REQUIREMENTS

- See Web Stiffener Requirements on page 18.

PROTECT AJS® JOISTS FROM THE WEATHER

- AJS® Joists are intended only for applications that provide permanent protection from the weather. Candles on AJS® Joists should be covered and stored out of the ground or stickers.

MAXIMUM SLOPE

- Unless otherwise noted, all roof details are valid for slopes of 12 in 12 or less.

VENTILATION

- The 1 1/2 inch, pre-stamped knock-out holes spaced at 12 inches on center along the AJS® Joist may all be knocked out and used for cross ventilation. Deeper joists than what is structurally needed may be advantageous in ventilation design. Consult local building official and/or ventilation specialist for specific ventilation requirements.

BIRDSMOUTH CUTS

- AJS® Joists may be birdsmouth cut only at the low end support. AJS® joists with birdsmouth cuts may cantilever up to 2'-6" past the low end support. The bottom flange must sit fully on the support and may not overhang the inside face of the support. High end supports and intermediate supports may not be birdsmouth cut.

Maximum clear span in feet and inches, based on horizontal spans.

		115% and 125% Load Duration													
		AJS® 20 Series 2 1/2" Flange Width													
		Live Load [psf]	Dead Load [psf]	9 1/2" AJS® 20			11 7/8" AJS® 20			14" AJS® 20			16" AJS® 20		
7/12 or Less	4/12 to 8/12			6/12 to 12/12	4/12 or Less	4/12 to 6/12	8/12 to 12/12	4/12 or Less	4/12 to 8/12	8/12 to 12/12	7/12 or Less	4/12 to 8/12	6/12 to 12/12		
12" c.c.	Non-Snow 126%	20	10	27'-4"	25'-9"	23'-11"	32'-7"	30'-9"	28'-7"	37'-1"	35'-0"	32'-6"	41'-2"	38'-10"	36'-0"
		20	15	25'-10"	24'-3"	22'-5"	30'-11"	29'-0"	26'-9"	35'-2"	33'-0"	30'-5"	39'-0"	36'-7"	33'-9"
		20	20	24'-8"	23'-1"	21'-3"	29'-6"	27'-7"	25'-4"	33'-6"	31'-5"	28'-10"	37'-2"	34'-10"	32'-0"
	Snow 115%	25	10	25'-11"	24'-6"	22'-10"	31'-0"	29'-3"	27'-3"	35'-3"	33'-4"	31'-0"	39'-1"	36'-11"	34'-4"
		25	15	24'-9"	23'-3"	21'-6"	29'-7"	27'-10"	25'-9"	33'-7"	31'-8"	29'-4"	36'-11"	33'-1"	32'-6"
		30	10	24'-9"	23'-6"	21'-11"	29'-7"	28'-0"	26'-2"	33'-8"	31'-11"	29'-9"	37'-1"	35'-4"	33'-0"
		30	15	23'-9"	22'-5"	20'-10"	28'-5"	26'-9"	24'-10"	32'-4"	30'-6"	28'-3"	34'-10"	33'-10"	31'-4"
		40	10	22'-6"	21'-7"	20'-5"	26'-11"	25'-10"	24'-5"	30'-8"	29'-5"	27'-9"	33'-2"	32'-7"	30'-9"
		40	15	22'-2"	21'-0"	19'-7"	26'-6"	25'-1"	23'-5"	29'-3"	28'-7"	26'-7"	31'-7"	30'-11"	29'-6"
		50	10	20'-10"	20'-1"	19'-0"	24'-11"	23'-11"	22'-9"	28'-1"	27'-3"	25'-10"	30'-3"	29'-11"	28'-8"
50	15	20'-10"	19'-11"	18'-7"	24'-6"	23'-9"	22'-3"	26'-11"	26'-6"	25'-3"	29'-0"	28'-7"	27'-11"		
16" o.c.	Non-Snow 125%	20	10	24'-9"	23'-4"	21'-8"	29'-7"	27'-11"	25'-11"	33'-8"	31'-9"	29'-5"	37'-4"	35'-2"	32'-8"
		20	15	23'-5"	22'-0"	20'-4"	28'-0"	26'-4"	24'-3"	31'-10"	29'-11"	27'-7"	35'-4"	33'-2"	30'-7"
		20	20	22'-4"	20'-11"	19'-3"	26'-8"	25'-0"	23'-6"	30'-5"	28'-5"	26'-2"	33'-3"	31'-7"	29'-0"
	Snow 115%	25	10	23'-6"	22'-2"	20'-8"	28'-1"	26'-6"	24'-8"	31'-10"	30'-2"	28'-1"	34'-3"	33'-6"	31'-2"
		25	15	22'-5"	21'-1"	19'-6"	26'-9"	25'-2"	23'-4"	29'-8"	28'-8"	26'-7"	32'-0"	31'-1"	29'-5"
		30	10	22'-5"	21'-3"	19'-10"	26'-10"	25'-5"	23'-9"	29'-9"	28'-11"	27'-0"	32'-1"	31'-6"	29'-11"
		30	15	21'-6"	20'-4"	18'-10"	25'-6"	24'-3"	22'-6"	28'-0"	27'-4"	25'-8"	30'-2"	29'-5"	28'-5"
		40	10	20'-5"	19'-7"	18'-6"	24'-3"	23'-5"	22'-1"	26'-8"	26'-3"	25'-2"	28'-8"	28'-3"	27'-9"
		40	15	20'-1"	19'-0"	17'-9"	23'-1"	22'-7"	21'-2"	25'-4"	24'-10"	24'-1"	27'-3"	26'-9"	26'-1"
		50	10	18'-11"	18'-1"	17'-2"	22'-2"	21'-8"	20'-7"	24'-4"	24'-0"	23'-5"	26'-2"	25'-11"	25'-5"
50	15	18'-7"	18'-0"	16'-10"	21'-3"	20'-10"	20'-1"	23'-4"	22'-11"	22'-5"	25'-1"	24'-8"	23'-7"		
18" o.c.	Non-Snow 125%	20	10	23'-3"	21'-11"	20'-4"	27'-9"	26'-2"	24'-4"	31'-7"	29'-10"	27'-8"	35'-1"	33'-1"	30'-8"
		20	15	22'-0"	20'-8"	19'-1"	26'-4"	24'-8"	22'-10"	29'-11"	28'-1"	25'-11"	32'-6"	31'-2"	28'-9"
		20	20	21'-0"	19'-8"	18'-1"	25'-1"	23'-6"	21'-7"	28'-1"	26'-9"	24'-7"	30'-4"	29'-3"	27'-3"
	Snow 115%	25	10	22'-1"	20'-10"	19'-5"	26'-4"	24'-11"	23'-3"	29'-0"	28'-4"	26'-5"	31'-3"	30'-7"	29'-3"
		25	15	21'-0"	19'-10"	18'-4"	24'-8"	23'-8"	21'-11"	27'-1"	26'-4"	24'-11"	29'-2"	28'-5"	27'-5"
		30	10	21'-1"	19'-11"	18'-8"	24'-9"	23'-10"	22'-3"	27'-2"	26'-8"	25'-4"	29'-3"	28'-9"	28'-0"
		30	15	20'-2"	19'-1"	17'-8"	23'-3"	22'-8"	21'-2"	25'-6"	24'-11"	24'-1"	27'-6"	26'-10"	26'-0"
		40	10	19'-2"	18'-5"	17'-4"	22'-1"	21'-10"	20'-9"	24'-3"	23'-11"	23'-5"	26'-2"	25'-9"	25'-3"
		40	15	18'-5"	17'-10"	16'-8"	21'-0"	20'-7"	19'-11"	23'-1"	22'-8"	22'-0"	24'-11"	24'-2"	22'-11"
		50	10	17'-8"	17'-0"	16'-2"	20'-2"	19'-11"	19'-4"	22'-2"	21'-11"	21'-6"	23'-2"	22'-7"	21'-10"
50	15	17'-0"	16'-8"	15'-9"	19'-4"	19'-0"	18'-7"	21'-0"	20'-3"	19'-4"	21'-3"	20'-7"	19'-8"		
24" o.c.	Non-Snow 125%	20	10	21'-6"	20'-4"	18'-10"	25'-9"	24'-3"	22'-6"	29'-2"	27'-7"	25'-8"	31'-5"	30'-8"	28'-5"
		20	15	20'-4"	19'-1"	17'-8"	24'-4"	22'-10"	21'-1"	26'-11"	26'-0"	24'-0"	29'-1"	28'-2"	26'-8"
		20	20	19'-5"	18'-2"	16'-9"	22'-11"	21'-9"	20'-0"	25'-2"	24'-3"	22'-9"	27'-1"	26'-2"	24'-11"
	Snow 115%	25	10	20'-5"	19'-4"	18'-0"	23'-7"	23'-1"	21'-6"	25'-11"	25'-5"	24'-6"	27'-11"	27'-4"	26'-7"
		25	15	19'-4"	18'-4"	17'-0"	22'-0"	21'-5"	20'-4"	24'-2"	23'-6"	22'-8"	26'-1"	25'-4"	24'-3"
		30	10	19'-4"	18'-6"	17'-3"	22'-1"	21'-8"	20'-8"	24'-3"	23'-10"	23'-3"	26'-2"	25'-8"	25'-0"
		30	15	18'-2"	17'-8"	16'-5"	20'-9"	20'-3"	19'-7"	22'-10"	22'-3"	21'-7"	24'-6"	23'-4"	21'-11"
		40	10	17'-4"	17'-0"	16'-1"	19'-9"	19'-6"	19'-1"	21'-8"	21'-3"	20'-5"	22'-2"	21'-6"	20'-8"
		40	15	16'-6"	16'-2"	15'-5"	18'-9"	18'-5"	17'-8"	19'-9"	19'-0"	18'-0"	20'-1"	19'-3"	18'-3"
		50	10	15'-10"	15'-7"	14'-11"	17'-11"	17'-6"	16'-11"	18'-2"	17'-9"	17'-2"	18'-6"	18'-0"	17'-5"
50	15	15'-2"	14'-11"	14'-7"	16'-5"	15'-11"	15'-2"	16'-9"	16'-2"	15'-5"	17'-0"	16'-5"	15'-8"		

- Table values are limited by shear, moment, total load deflection equal to L/180 and live load deflection equal to L/240. Check the local building code for other deflection limits that may apply.
- Table values represent the most restrictive of simple or multiple span applications. Analyze multiple span joists with the BC Calc software if the length of any span is less than half the length of an adjacent span.
- Table values assume minimum bearing lengths without web stiffeners for joist depths of 13 inches and less.
- This table was designed to apply to a broad range of applications. It may be possible to exceed the limitations of this table by analyzing a specific application with the BC CALC® software.
- Slope roof joists at least 1/4" over 12" to minimize ponding.
- Allowable spans and loads shall be adjusted and checked for wind load as required by local building code.

AJS® Roof Span Tables

Maximum clear span in feet and inches, based on horizontal spans.

115% and 125% Load Duration

			AJS® 190 Series 2½" Flange Width												
			9½" AJS® 190			11¼" AJS® 190			14" AJS® 190			16" AJS® 190			
			Live Load [psf]	Dead Load [psf]	4/12 or Less	4/12 to 8/12	8/12 to 12/12	4/12 or Less	4/12 to 8/12	8/12 to 12/12	4/12 or Less	4/12 to 8/12	8/12 to 12/12	4/12 or Less	4/12 to 8/12
12" o.c.	Non-Snow 125%	20	10	27'-3"	25'-2"	24'-3"	33'-2"	31'-3"	29'-0"	37'-9"	31'-7"	33'-0"	41'-10"	39'-6"	36'-7"
		20	15	26'-3"	24'-8"	22'-9"	31'-1"	29'-6"	27'-3"	35'-9"	33'-7"	31'-0"	39'-8"	37'-3"	34'-4"
		20	20	25'-1"	23'-6"	21'-7"	30'-0"	28'-1"	25'-9"	34'-1"	31'-11"	29'-4"	37'-11"	35'-5"	32'-1"
	Snow 115%	25	10	26'-4"	24'-11"	23'-2"	31'-6"	29'-9"	27'-8"	35'-10"	33'-10"	31'-6"	39'-9"	37'-1"	34'-11"
		25	15	25'-2"	23'-8"	21'-11"	30'-0"	28'-3"	26'-2"	34'-2"	32'-2"	29'-9"	37'-11"	35'-8"	33'-0"
		30	10	25'-2"	23'-10"	22'-3"	30'-1"	28'-6"	26'-1"	34'-3"	32'-5"	30'-3"	38'-1"	36'-0"	33'-7"
		30	15	24'-2"	22'-9"	21'-2"	28'-10"	27'-3"	25'-3"	32'-10"	31'-0"	28'-9"	33'-5"	34'-4"	31'-11"
		40	10	22'-11"	22'-0"	20'-9"	27'-5"	25'-5"	24'-10"	31'-2"	29'-11"	28'-3"	34'-1"	33'-2"	31'-4"
		40	15	22'-11"	21'-4"	19'-11"	27'-0"	25'-0"	23'-9"	30'-8"	29'-1"	27'-1"	33'-11"	32'-3"	31'-0"
		50	10	21'-2"	20'-4"	19'-4"	25'-4"	24'-4"	23'-1"	28'-11"	27'-8"	25'-3"	32'-9"	30'-9"	29'-2"
50	15	21'-3"	20'-3"	18'-11"	25'-4"	24'-2"	22'-7"	28'-10"	27'-6"	25'-8"	31'-1"	30'-6"	28'-1"		
16" o.c.	Non-Snow 125%	20	10	25'-2"	23'-9"	22'-0"	30'-1"	28'-4"	26'-4"	34'-2"	32'-3"	29'-11"	37'-11"	35'-9"	33'-2"
		20	15	23'-11"	22'-4"	21'-8"	28'-6"	26'-9"	24'-8"	32'-5"	30'-5"	28'-1"	35'-11"	33'-9"	31'-2"
		20	20	22'-9"	21'-3"	19'-7"	27'-2"	25'-5"	23'-4"	30'-11"	28'-11"	26'-7"	34'-3"	32'-1"	29'-5"
	Snow 115%	25	10	23'-10"	22'-7"	21'-0"	28'-6"	27'-9"	25'-1"	32'-0"	30'-8"	28'-7"	36'-1"	34'-1"	31'-8"
		25	15	22'-9"	21'-5"	19'-10"	27'-2"	25'-7"	23'-9"	31'-0"	29'-2"	27'-0"	34'-3"	32'-4"	29'-11"
		30	10	22'-11"	21'-1"	20'-2"	27'-3"	25'-10"	24'-1"	31'-0"	29'-5"	27'-5"	34'-4"	32'-1"	30'-5"
		30	15	21'-10"	20'-8"	19'-2"	26'-2"	24'-8"	22'-11"	29'-9"	28'-1"	26'-1"	32'-4"	31'-2"	28'-11"
		40	10	20'-9"	19'-11"	18'-10"	24'-10"	23'-10"	22'-6"	28'-3"	27'-1"	25'-7"	30'-9"	30'-1"	28'-5"
		40	15	20'-9"	19'-4"	18'-0"	24'-5"	23'-1"	21'-11"	27'-2"	26'-4"	24'-6"	29'-3"	28'-8"	27'-2"
		50	10	19'-2"	18'-5"	17'-0"	22'-11"	22'-11"	20'-11"	26'-1"	25'-1"	23'-10"	27'-10"	27'-2"	26'-3"
50	15	19'-2"	18'-4"	17'-1"	22'-9"	21'-11"	20'-5"	25'-0"	24'-5"	23'-3"	25'-7"	24'-9"	23'-1"		
19.2" o.c.	Non-Snow 125%	20	10	23'-7"	22'-3"	21'-8"	28'-3"	26'-8"	24'-9"	32'-2"	30'-4"	28'-2"	35'-8"	33'-1"	31'-3"
		20	15	22'-4"	21'-0"	19'-5"	26'-9"	25'-1"	23'-2"	30'-5"	28'-7"	26'-5"	33'-9"	31'-8"	29'-3"
		20	20	21'-4"	20'-0"	18'-4"	25'-6"	23'-10"	21'-11"	29'-0"	27'-2"	25'-0"	32'-2"	30'-2"	27'-9"
	Snow 115%	25	10	22'-5"	21'-2"	19'-9"	27'-10"	25'-4"	23'-7"	30'-1"	28'-10"	26'-10"	33'-6"	32'-0"	29'-9"
		25	15	21'-4"	20'-2"	18'-8"	25'-7"	24'-1"	22'-3"	29'-0"	27'-5"	25'-4"	31'-3"	30'-5"	28'-2"
		30	10	21'-5"	20'-4"	18'-11"	25'-7"	24'-3"	22'-8"	29'-1"	27'-7"	25'-9"	31'-4"	30'-8"	28'-7"
		30	15	20'-6"	19'-5"	18'-0"	24'-7"	23'-2"	21'-6"	27'-4"	26'-4"	24'-6"	29'-6"	28'-9"	27'-2"
		40	10	19'-6"	18'-8"	17'-8"	23'-3"	22'-4"	21'-1"	26'-0"	25'-5"	24'-0"	27'-9"	27'-0"	25'-11"
		40	15	19'-2"	18'-2"	16'-11"	22'-6"	21'-8"	20'-3"	24'-9"	23'-10"	22'-7"	25'-2"	24'-2"	22'-11"
		50	10	18'-0"	17'-3"	16'-5"	21'-6"	20'-8"	19'-8"	22'-10"	22'-3"	21'-6"	23'-2"	22'-7"	21'-10"
50	15	18'-1"	17'-2"	16'-1"	20'-7"	19'-11"	19'-0"	21'-0"	20'-3"	19'-4"	21'-3"	20'-1"	19'-8"		
24" o.c.	Non-Snow 125%	20	10	21'-11"	20'-8"	19'-2"	26'-2"	24'-8"	22'-11"	29'-9"	28'-1"	26'-1"	33'-0"	31'-2"	28'-11"
		20	15	20'-8"	19'-5"	18'-0"	24'-9"	23'-3"	21'-6"	28'-2"	26'-6"	24'-5"	31'-1"	29'-4"	27'-1"
		20	20	19'-9"	18'-6"	17'-0"	23'-7"	22'-1"	20'-4"	26'-10"	25'-2"	23'-2"	29'-0"	27'-9"	25'-3"
	Snow 115%	25	10	20'-9"	19'-8"	18'-3"	24'-10"	23'-6"	21'-11"	27'-9"	26'-9"	24'-11"	29'-11"	29'-4"	27'-1"
		25	15	19'-9"	18'-8"	17'-3"	23'-7"	22'-3"	20'-8"	25'-11"	25'-3"	23'-6"	27'-0"	26'-1"	24'-11"
		30	10	19'-11"	18'-9"	17'-11"	23'-8"	22'-0"	21'-0"	26'-0"	25'-6"	23'-10"	27'-9"	26'-9"	25'-5"
		30	15	19'-11"	17'-11"	16'-8"	22'-3"	21'-5"	19'-11"	24'-2"	23'-0"	21'-7"	24'-0"	23'-4"	21'-11"
		40	10	18'-0"	17'-3"	16'-4"	21'-2"	20'-8"	19'-7"	21'-10"	21'-3"	20'-5"	22'-2"	21'-6"	20'-8"
		40	15	17'-8"	16'-9"	15'-8"	19'-11"	18'-8"	17'-8"	19'-9"	19'-0"	18'-0"	20'-1"	19'-3"	18'-3"
		50	10	16'-8"	16'-0"	15'-2"	17'-11"	17'-0"	16'-11"	18'-2"	17'-9"	17'-2"	18'-6"	18'-0"	17'-5"
50	15	16'-2"	15'-8"	14'-10"	16'-5"	15'-11"	15'-2"	16'-9"	16'-2"	15'-5"	17'-11"	16'-5"	15'-8"		

- Table values are limited by shear, moment, total load deflection equal to L/180 and live load deflection equal to L/240. Check the local building code for other deflection limits that may apply.
- Table values represent the most restrictive of simple or multiple span applications. Analyze multiple span joists with the BC Calc software if the length of any span is less than half the length of an adjacent span.
- Table values assume minimum bearing lengths without web stiffeners for joist depths of 16 inches and less. 18" joists require web stiffeners at all bearing locations.

- This table was designed to apply to a broad range of applications. It may be possible to exceed the limitations of this table by analyzing a specific application with the BC CALC® software.
- Slope roof joists at least ¼" over 12" to minimize ponding.
- Allowable spans and loads shall be adjusted and checked for wind load as required by local building code.

Maximum clear span in feet and inches, based on horizontal spans.

115% and 125% Load Duration

		AJS® 25 Series — 9½" - 16" Depths 3/8" Web Thickness — 3½" Flange Width													
		Live Load [psf] Dead Load [psf]		9½" AJS® 25			11½" AJS® 25			14" AJS® 25			16" AJS® 25		
				4/12 or Less	4/12 to 8/12	8/12 to 12/12	4/12 or Less	4/12 to 8/12	8/12 to 12/12	4/12 or Less	4/12 to 8/12	8/12 to 12/12	4/12 or Less	4/12 to 8/12	8/12 to 12/12
12" o.c.	Non-Snow 125%	20	10	30'-5"	28'-9"	26'-8"	36'-4"	34'-3"	31'-10"	41'-4"	38'-11"	36'-2"	45'-9"	43'-2"	40'-1"
		20	15	28'-10"	27'-1"	25'-0"	34'-5"	32'-4"	29'-10"	39'-1"	36'-9"	33'-11"	43'-4"	40'-8"	37'-7"
		20	20	27'-6"	25'-9"	23'-8"	32'-10"	30'-9"	28'-3"	37'-4"	34'-11"	32'-2"	41'-4"	38'-9"	35'-7"
	Snow 115%	25	10	28'-11"	27'-4"	25'-5"	34'-6"	32'-7"	30'-4"	39'-3"	37'-1"	34'-6"	43'-5"	41'-1"	38'-3"
		25	15	27'-7"	25'-11"	24'-0"	32'-11"	31'-0"	28'-8"	37'-5"	35'-3"	32'-7"	41'-5"	39'-0"	36'-2"
		30	10	27'-8"	26'-2"	24'-5"	33'-0"	31'-3"	29'-2"	37'-6"	35'-6"	33'-2"	41'-6"	39'-4"	36'-8"
		30	15	26'-6"	25'-0"	23'-2"	31'-8"	29'-10"	27'-8"	35'-11"	33'-11"	31'-6"	39'-10"	37'-7"	34'-11"
		40	10	25'-2"	24'-1"	22'-9"	30'-0"	28'-9"	27'-2"	34'-1"	32'-9"	30'-11"	37'-10"	36'-3"	34'-3"
		40	15	24'-9"	23'-5"	21'-10"	29'-7"	28'-0"	26'-1"	33'-7"	31'-10"	29'-8"	37'-3"	35'-3"	32'-10"
		50	10	23'-3"	22'-4"	21'-2"	27'-9"	26'-8"	25'-4"	31'-7"	30'-4"	28'-9"	35'-0"	33'-7"	31'-11"
50	15	23'-3"	22'-2"	20'-9"	27'-9"	26'-6"	24'-9"	31'-7"	30'-1"	28'-2"	35'-0"	33'-4"	31'-2"		
16" o.c.	Non-Snow 125%	20	10	27'-7"	26'-0"	24'-2"	32'-11"	31'-1"	28'-10"	37'-5"	35'-4"	32'-9"	41'-6"	39'-2"	36'-4"
		20	15	26'-1"	24'-6"	22'-8"	31'-2"	29'-3"	27'-1"	35'-5"	33'-4"	30'-9"	39'-3"	36'-11"	34'-1"
		20	20	24'-11"	23'-4"	21'-5"	29'-9"	27'-10"	25'-7"	33'-10"	31'-8"	29'-1"	37'-6"	35'-1"	32'-3"
	Snow 115%	25	10	26'-2"	24'-9"	23'-1"	31'-3"	29'-7"	27'-6"	35'-6"	33'-7"	31'-3"	39'-5"	37'-3"	34'-8"
		25	15	25'-0"	23'-6"	21'-9"	29'-10"	28'-1"	26'-0"	33'-11"	31'-11"	29'-7"	37'-7"	35'-4"	32'-9"
		30	10	25'-0"	23'-8"	22'-1"	29'-10"	28'-4"	26'-5"	34'-0"	32'-2"	30'-0"	37'-8"	35'-8"	33'-3"
		30	15	24'-0"	22'-8"	21'-0"	28'-8"	27'-0"	25'-1"	32'-7"	30'-9"	28'-6"	36'-1"	34'-1"	31'-7"
		40	10	22'-9"	21'-10"	20'-7"	27'-2"	26'-1"	24'-8"	30'-11"	29'-8"	28'-0"	34'-3"	32'-10"	31'-0"
		40	15	22'-5"	21'-2"	19'-9"	26'-9"	25'-4"	23'-7"	30'-5"	28'-10"	26'-10"	33'-8"	31'-11"	29'-9"
		50	10	21'-0"	20'-2"	19'-2"	25'-2"	24'-2"	22'-11"	28'-7"	27'-5"	26'-1"	31'-8"	30'-5"	28'-11"
50	15	21'-0"	20'-1"	18'-9"	25'-2"	24'-0"	22'-5"	28'-7"	27'-3"	25'-6"	29'-7"	28'-8"	27'-4"		
19.2" o.c.	Non-Snow 125%	20	10	25'-11"	24'-5"	22'-8"	30'-11"	29'-2"	27'-1"	35'-2"	33'-2"	30'-10"	39'-0"	36'-9"	34'-2"
		20	15	24'-6"	23'-0"	21'-3"	29'-3"	27'-6"	25'-5"	33'-3"	31'-3"	28'-11"	36'-11"	34'-8"	32'-0"
		20	20	23'-5"	21'-11"	20'-2"	27'-11"	26'-2"	24'-1"	31'-9"	29'-9"	27'-4"	35'-2"	32'-11"	30'-4"
	Snow 115%	25	10	24'-7"	23'-3"	21'-8"	29'-4"	27'-9"	25'-10"	33'-5"	31'-7"	29'-5"	37'-0"	35'-0"	32'-7"
		25	15	23'-5"	22'-1"	20'-5"	28'-0"	26'-4"	24'-5"	31'-10"	30'-0"	27'-9"	35'-3"	33'-3"	30'-9"
		30	10	23'-6"	22'-3"	20'-9"	28'-1"	26'-7"	24'-10"	31'-11"	30'-3"	28'-3"	35'-4"	33'-6"	31'-3"
		30	15	22'-6"	21'-3"	19'-9"	26'-11"	25'-5"	23'-7"	30'-7"	28'-10"	26'-10"	33'-11"	32'-0"	29'-8"
		40	10	21'-4"	20'-6"	19'-4"	25'-6"	24'-6"	23'-2"	29'-0"	27'-10"	26'-4"	32'-2"	30'-10"	29'-2"
		40	15	21'-0"	19'-11"	18'-7"	25'-1"	23'-9"	22'-2"	28'-3"	27'-0"	25'-3"	29'-1"	28'-0"	26'-6"
		50	10	19'-9"	18'-11"	18'-0"	23'-7"	22'-8"	21'-6"	26'-1"	25'-5"	24'-6"	26'-10"	26'-2"	25'-3"
50	15	19'-9"	18'-10"	17'-7"	23'-3"	22'-6"	21'-0"	23'-11"	23'-2"	22'-1"	24'-8"	23'-10"	22'-9"		
24" o.c.	Non-Snow 125%	20	10	24'-0"	22'-8"	21'-0"	28'-8"	27'-0"	25'-1"	32'-7"	30'-9"	28'-6"	36'-1"	34'-1"	31'-7"
		20	15	22'-8"	21'-4"	19'-8"	27'-1"	25'-6"	23'-6"	30'-10"	29'-0"	26'-9"	34'-2"	32'-1"	29'-8"
		20	20	21'-8"	20'-3"	18'-8"	25'-10"	24'-3"	22'-3"	29'-5"	27'-6"	25'-4"	32'-7"	30'-6"	28'-1"
	Snow 115%	25	10	22'-9"	21'-6"	20'-1"	27'-2"	25'-9"	23'-11"	30'-11"	29'-3"	27'-3"	34'-3"	32'-5"	30'-2"
		25	15	21'-8"	20'-5"	18'-11"	25'-11"	24'-5"	22'-7"	29'-5"	27'-9"	25'-9"	31'-10"	30'-2"	28'-1"
		30	10	21'-9"	20'-7"	19'-3"	25'-11"	24'-7"	23'-0"	29'-6"	28'-0"	26'-2"	32'-1"	30'-11"	28'-11"
		30	15	20'-10"	19'-8"	18'-3"	24'-10"	23'-6"	21'-10"	27'-7"	26'-3"	24'-7"	28'-4"	27'-0"	25'-4"
		40	10	19'-9"	18'-11"	17'-11"	23'-7"	22'-8"	21'-5"	24'-11"	24'-3"	23'-3"	25'-8"	24'-11"	23'-11"
		40	15	19'-5"	18'-5"	17'-2"	21'-11"	21'-1"	19'-11"	22'-7"	21'-8"	20'-7"	23'-3"	22'-4"	21'-2"
		50	10	18'-3"	17'-6"	16'-8"	20'-2"	19'-8"	19'-0"	20'-9"	20'-3"	19'-7"	21'-5"	20'-11"	20'-2"
50	15	17'-11"	17'-4"	16'-3"	18'-7"	17'-11"	17'-1"	19'-1"	18'-6"	17'-8"	19'-8"	19'-0"	18'-2"		



AJS® Roof Span Tables

Maximum clear span in feet and inches, based on horizontal spans.

115% and 125% Load Duration

AJS® 25 Series — Deeper Depths — 18" - 24" Depths
⁷/₈" Web Thickness — 3½" Flange Width

		Live Load [psf]	Dead Load [psf]	AJS® 25 Series — Deeper Depths — 18" - 24" Depths ⁷ / ₈ " Web Thickness — 3½" Flange Width											
				18" AJS® 25			20" AJS® 25			22" AJS® 25			24" AJS® 25		
				4/12 or Less	4/12 to 8/12	8/12 to 12/12	4/12 or Less	4/12 to 8/12	8/12 to 12/12	4/12 or Less	4/12 to 8/12	8/12 to 12/12	4/12 or Less	4/12 to 8/12	8/12 to 12/12
12" o.c.	Non-Snow 125%	20	10	48'-0"	47'-5"	44'-0"	48'-0"	48'-0"	48'-0"	48'-0"	48'-0"	48'-0"	48'-0"	48'-0"	48'-0"
		20	15	47'-8"	44'-9"	41'-3"	48'-0"	48'-0"	44'-9"	48'-0"	48'-0"	48'-0"	48'-0"	48'-0"	48'-0"
		20	20	45'-5"	42'-7"	39'-1"	48'-0"	46'-1"	42'-5"	48'-0"	48'-0"	45'-7"	48'-0"	48'-0"	48'-0"
	Snow 115%	25	10	47'-9"	45'-2"	42'-0"	48'-0"	48'-0"	45'-6"	48'-0"	48'-0"	48'-0"	48'-0"	48'-0"	48'-0"
		25	15	45'-7"	42'-11"	39'-8"	48'-0"	46'-6"	43'-0"	48'-0"	48'-0"	46'-3"	48'-0"	48'-0"	48'-0"
		30	10	45'-8"	43'-3"	40'-4"	48'-0"	46'-10"	43'-8"	48'-0"	48'-0"	47'-0"	48'-0"	48'-0"	48'-0"
		30	15	43'-10"	41'-4"	38'-4"	47'-6"	44'-9"	41'-7"	48'-0"	48'-0"	44'-8"	48'-0"	48'-0"	47'-8"
		40	10	41'-7"	39'-10"	37'-7"	45'-1"	43'-2"	40'-9"	48'-0"	46'-5"	43'-10"	48'-0"	48'-0"	46'-10"
		40	15	40'-11"	38'-9"	36'-1"	44'-4"	42'-0"	39'-1"	46'-10"	45'-2"	42'-0"	48'-0"	47'-11"	44'-11"
		50	10	38'-6"	36'-11"	35'-1"	41'-9"	40'-0"	38'-0"	44'-11"	43'-0"	40'-10"	46'-11"	46'-0"	43'-7"
50	15	38'-6"	36'-8"	34'-3"	41'-2"	39'-9"	37'-2"	43'-1"	42'-5"	39'-11"	44'-11"	44'-3"	42'-8"		
16" o.c.	Non-Snow 125%	20	10	45'-7"	43'-0"	39'-11"	48'-0"	46'-7"	43'-3"	48'-0"	48'-0"	46'-6"	48'-0"	48'-0"	48'-0"
		20	15	43'-2"	40'-7"	37'-5"	46'-10"	43'-11"	40'-7"	48'-0"	47'-3"	43'-7"	48'-0"	48'-0"	46'-7"
		20	20	41'-2"	38'-7"	35'-6"	44'-8"	41'-10"	38'-5"	48'-0"	44'-11"	41'-4"	48'-0"	48'-0"	44'-2"
	Snow 115%	25	10	43'-4"	40'-11"	38'-1"	46'-11"	44'-4"	41'-3"	48'-0"	47'-8"	44'-5"	48'-0"	48'-0"	47'-5"
		25	15	41'-4"	38'-11"	36'-0"	44'-9"	42'-2"	39'-0"	47'-5"	45'-4"	41'-11"	48'-0"	48'-0"	44'-10"
		30	10	41'-5"	39'-2"	36'-7"	44'-10"	42'-6"	39'-8"	47'-7"	45'-8"	42'-7"	48'-0"	48'-0"	45'-6"
		30	15	39'-8"	37'-5"	34'-9"	42'-9"	40'-7"	37'-8"	44'-9"	43'-8"	40'-6"	46'-8"	45'-7"	43'-3"
		40	10	37'-8"	36'-2"	34'-1"	40'-8"	39'-2"	37'-0"	42'-7"	42'-0"	39'-9"	44'-5"	43'-9"	42'-5"
		40	15	36'-7"	35'-1"	32'-9"	38'-8"	37'-11"	35'-5"	40'-6"	39'-9"	38'-1"	42'-3"	41'-5"	40'-4"
		50	10	34'-11"	33'-6"	31'-9"	37'-2"	36'-3"	34'-5"	38'-11"	38'-5"	37'-0"	40'-7"	40'-1"	39'-5"
50	15	33'-8"	33'-1"	31'-1"	35'-7"	35'-0"	33'-8"	37'-4"	36'-8"	35'-10"	38'-11"	38'-3"	37'-5"		
19.2" o.c.	Non-Snow 125%	20	10	42'-10"	40'-5"	37'-6"	46'-5"	43'-10"	40'-8"	48'-0"	47'-1"	43'-8"	48'-0"	48'-0"	46'-8"
		20	15	40'-7"	38'-1"	35'-2"	44'-0"	41'-4"	38'-2"	47'-3"	44'-5"	41'-0"	48'-0"	47'-5"	43'-9"
		20	20	38'-9"	36'-3"	33'-4"	41'-11"	39'-3"	36'-2"	45'-0"	42'-3"	38'-10"	46'-11"	45'-1"	41'-6"
	Snow 115%	25	10	40'-8"	38'-10"	35'-10"	44'-1"	41'-8"	38'-10"	46'-5"	44'-10"	41'-9"	48'-0"	47'-5"	44'-7"
		25	15	38'-10"	36'-6"	33'-10"	41'-4"	39'-7"	36'-8"	43'-3"	42'-2"	39'-5"	45'-2"	43'-11"	42'-1"
		30	10	38'-11"	36'-10"	34'-4"	41'-5"	39'-11"	37'-3"	43'-5"	42'-8"	40'-1"	45'-3"	44'-6"	42'-9"
		30	15	36'-10"	35'-2"	32'-8"	39'-0"	38'-1"	35'-5"	40'-10"	39'-11"	38'-1"	42'-7"	41'-7"	40'-3"
		40	10	35'-1"	33'-11"	32'-1"	37'-1"	36'-7"	34'-9"	38'-10"	38'-4"	37'-4"	40'-6"	39'-11"	39'-2"
		40	15	33'-4"	32'-9"	30'-9"	35'-4"	34'-7"	33'-4"	37'-0"	36'-3"	35'-3"	38'-7"	37'-10"	36'-10"
		50	10	32'-0"	31'-5"	29'-10"	33'-11"	33'-6"	32'-4"	35'-6"	35'-1"	34'-6"	37'-0"	36'-7"	35'-11"
50	15	30'-8"	30'-2"	29'-2"	32'-6"	31'-11"	31'-3"	34'-0"	33'-6"	32'-8"	35'-6"	34'-11"	34'-1"		
24" o.c.	Non-Snow 125%	20	10	39'-8"	37'-5"	34'-9"	43'-0"	40'-7"	37'-8"	46'-3"	43'-8"	40'-6"	48'-0"	46'-7"	43'-3"
		20	15	37'-7"	35'-4"	32'-7"	40'-9"	38'-3"	35'-4"	43'-1"	41'-2"	38'-0"	44'-11"	43'-7"	40'-7"
		20	20	35'-10"	33'-7"	30'-11"	38'-5"	36'-5"	33'-6"	40'-2"	38'-10"	36'-0"	41'-11"	40'-6"	38'-5"
	Snow 115%	25	10	37'-5"	35'-8"	33'-2"	39'-7"	38'-8"	36'-0"	41'-6"	40'-8"	38'-8"	43'-3"	42'-4"	41'-2"
		25	15	34'-11"	33'-10"	31'-4"	36'-11"	35'-11"	34'-0"	38'-8"	37'-8"	36'-4"	40'-4"	39'-3"	37'-11"
		30	10	35'-0"	34'-1"	31'-10"	37'-1"	36'-5"	34'-6"	38'-10"	38'-1"	37'-1"	40'-6"	39'-9"	38'-9"
		30	15	32'-11"	32'-2"	30'-3"	34'-10"	34'-0"	32'-10"	36'-6"	35'-8"	34'-6"	38'-1"	37'-2"	36'-0"
		40	10	31'-4"	30'-11"	29'-8"	33'-2"	32'-8"	32'-0"	34'-9"	34'-3"	33'-7"	36'-3"	35'-8"	35'-0"
		40	15	29'-10"	29'-3"	28'-5"	31'-6"	30'-11"	30'-1"	33'-0"	32'-5"	31'-6"	34'-6"	33'-9"	32'-11"
		50	10	28'-7"	28'-3"	27'-8"	30'-3"	29'-11"	29'-5"	31'-9"	31'-4"	30'-10"	33'-1"	32'-8"	32'-2"
50	15	27'-5"	27'-0"	26'-4"	29'-0"	28'-7"	27'-11"	30'-5"	29'-11"	29'-3"	31'-9"	31'-2"	30'-6"		

- Table values are limited by shear, moment, total load deflection equal to L/180 and live load deflection equal to L/240. Check the local building code for other deflection limits that may apply.
- Table values represent the most restrictive of simple or multiple span applications. Analyze multiple span joists with the BC Calc software if the length of any span is less than half the length of an adjacent span.
- Table values assume minimum bearing lengths, no web stiffeners for joist depths of 16" and less, web stiffeners required at all bearing locations for 18" and deeper joists.
- This table was designed to apply to a broad range of applications. It may be possible to exceed the limitations of this table by analyzing a specific application with the BC CALC® software.
- Slope roof joists at least ¼" over 12" to minimize ponding.
- Allowable spans and loads shall be adjusted and checked for wind load as required by local building code.

Maximum clear span in feet and inches, based on horizontal spans.

115% and 125% Load Duration															
AJS® 30 Series — 18" - 24" Depths 3/8" Web Thickness — 3 1/2" Flange Width															
		18" AJS® 30			20" AJS® 30			22" AJS® 30			24" AJS® 20				
		Live Load [psf]	Dead Load [psf]	4/12 or Less	4/12 to 8/12	8/12 to 12/12	4/12 or Less	4/12 to 8/12	8/12 to 12/12	4/12 or Less	4/12 to 8/12	8/12 to 12/12	4/12 or Less	4/12 to 8/12	8/12 to 12/12
12" o.c.	Non-Snow 125%	20	10	48'-0"	48'-0"	45'-5"	48'-0"	48'-0"	48'-0"	48'-0"	48'-0"	48'-0"	48'-0"	48'-0"	48'-0"
		20	15	48'-0"	46'-3"	42'-8"	48'-0"	48'-0"	46'-2"	48'-0"	48'-0"	48'-0"	48'-0"	48'-0"	48'-0"
		20	20	47'-0"	44'-0"	40'-5"	48'-0"	47'-7"	43'-9"	48'-0"	48'-0"	47'-1"	48'-0"	48'-0"	48'-0"
	Snow 115%	25	10	48'-0"	46'-8"	43'-5"	48'-0"	48'-0"	47'-0"	48'-0"	48'-0"	48'-0"	48'-0"	48'-0"	48'-0"
		25	15	47'-1"	44'-4"	41'-0"	48'-0"	48'-0"	44'-5"	48'-0"	48'-0"	47'-9"	48'-0"	48'-0"	48'-0"
		30	10	47'-2"	44'-8"	41'-8"	48'-0"	48'-0"	45'-2"	48'-0"	48'-0"	48'-0"	48'-0"	48'-0"	48'-0"
		30	15	45'-3"	42'-8"	39'-7"	48'-0"	46'-3"	42'-11"	48'-0"	48'-0"	46'-1"	48'-0"	48'-0"	48'-0"
		40	10	43'-0"	41'-2"	38'-11"	46'-6"	44'-7"	42'-1"	48'-0"	47'-11"	45'-3"	48'-0"	48'-0"	48'-0"
		40	15	42'-4"	40'-0"	37'-3"	45'-10"	43'-4"	40'-5"	48'-0"	46'-7"	43'-5"	48'-0"	48'-0"	46'-4"
		50	10	39'-10"	38'-2"	36'-3"	43'-1"	41'-4"	39'-3"	46'-4"	44'-5"	42'-2"	48'-0"	47'-6"	45'-0"
50	15	39'-10"	37'-11"	35'-5"	43'-1"	41'-1"	38'-4"	46'-4"	44'-2"	41'-3"	48'-0"	47'-2"	44'-0"		
16" o.c.	Non-Snow 125%	20	10	47'-1"	44'-5"	41'-3"	48'-0"	48'-0"	44'-8"	48'-0"	48'-0"	48'-0"	48'-0"	48'-0"	48'-0"
		20	15	44'-7"	41'-11"	38'-8"	48'-0"	45'-5"	41'-11"	48'-0"	48'-0"	45'-0"	48'-0"	48'-0"	48'-0"
		20	20	42'-7"	39'-10"	36'-8"	46'-1"	43'-2"	39'-8"	48'-0"	46'-5"	42'-8"	48'-0"	48'-0"	45'-7"
	Snow 115%	25	10	44'-9"	42'-4"	39'-4"	48'-0"	45'-10"	42'-8"	48'-0"	48'-0"	45'-10"	48'-0"	48'-0"	48'-0"
		25	15	42'-8"	40'-2"	37'-2"	46'-3"	43'-6"	40'-4"	48'-0"	46'-9"	43'-4"	48'-0"	48'-0"	46'-3"
		30	10	42'-9"	40'-6"	37'-9"	46'-4"	43'-11"	40'-11"	48'-0"	47'-2"	44'-0"	48'-0"	48'-0"	47'-0"
		30	15	41'-0"	38'-8"	35'-11"	44'-5"	41'-11"	38'-11"	47'-9"	45'-1"	41'-10"	48'-0"	48'-0"	44'-8"
		40	10	38'-11"	37'-4"	35'-3"	42'-2"	40'-5"	38'-2"	45'-4"	43'-6"	41'-0"	48'-0"	46'-5"	43'-10"
		40	15	38'-4"	36'-3"	33'-10"	41'-6"	39'-4"	36'-7"	44'-8"	42'-3"	39'-4"	47'-7"	45'-1"	42'-0"
		50	10	36'-1"	34'-7"	32'-10"	39'-1"	37'-6"	35'-7"	42'-0"	40'-3"	38'-3"	44'-10"	43'-0"	40'-10"
50	15	36'-1"	34'-4"	32'-1"	39'-1"	37'-2"	34'-9"	42'-0"	40'-0"	37'-5"	43'-10"	42'-9"	39'-11"		
19.2" o.c.	Non-Snow 125%	20	10	44'-3"	41'-9"	38'-9"	47'-11"	45'-3"	42'-0"	48'-0"	48'-0"	45'-1"	48'-0"	48'-0"	48'-0"
		20	15	41'-11"	39'-5"	36'-4"	45'-5"	42'-8"	39'-5"	48'-0"	45'-10"	42'-4"	48'-0"	48'-0"	45'-2"
		20	20	40'-0"	37'-5"	34'-5"	43'-4"	40'-7"	37'-4"	46'-7"	43'-7"	40'-1"	48'-0"	46'-7"	42'-10"
	Snow 115%	25	10	42'-0"	39'-9"	37'-0"	45'-6"	43'-1"	40'-1"	48'-0"	46'-3"	43'-1"	48'-0"	48'-0"	46'-0"
		25	15	40'-1"	37'-9"	35'-0"	43'-5"	40'-11"	37'-10"	46'-8"	43'-11"	40'-8"	48'-0"	46'-11"	43'-6"
		30	10	40'-2"	38'-1"	35'-6"	43'-6"	41'-3"	38'-6"	46'-9"	44'-4"	41'-4"	48'-0"	47'-4"	44'-2"
		30	15	38'-6"	36'-4"	33'-9"	41'-9"	39'-5"	36'-7"	44'-10"	42'-4"	39'-4"	47'-11"	45'-3"	42'-0"
		40	10	36'-7"	35'-1"	33'-1"	39'-7"	38'-0"	35'-11"	42'-7"	40'-10"	38'-7"	45'-6"	43'-7"	41'-2"
		40	15	36'-0"	34'-1"	31'-9"	39'-0"	36'-11"	34'-5"	41'-8"	39'-8"	37'-0"	43'-5"	42'-5"	39'-6"
		50	10	33'-10"	32'-6"	30'-10"	36'-8"	35'-2"	33'-5"	39'-5"	37'-10"	35'-11"	41'-8"	40'-5"	38'-4"
50	15	33'-10"	32'-3"	30'-2"	36'-7"	34'-11"	32'-8"	38'-4"	37'-7"	35'-1"	40'-0"	39'-4"	37'-6"		
24" o.c.	Non-Snow 125%	20	10	41'-0"	38'-8"	35'-11"	44'-5"	41'-11"	38'-11"	47'-9"	45'-1"	41'-10"	48'-0"	48'-0"	44'-8"
		20	15	38'-10"	36'-6"	33'-8"	42'-1"	39'-6"	36'-6"	45'-3"	42'-6"	39'-3"	48'-0"	45'-4"	41'-11"
		20	20	37'-0"	34'-8"	31'-11"	40'-2"	37'-7"	34'-7"	43'-2"	40'-5"	37'-2"	46'-1"	43'-2"	39'-8"
	Snow 115%	25	10	38'-11"	36'-10"	34'-3"	42'-2"	39'-11"	37'-2"	45'-4"	42'-11"	39'-11"	48'-0"	45'-9"	42'-8"
		25	15	37'-1"	35'-0"	32'-5"	40'-3"	37'-11"	35'-1"	43'-3"	40'-9"	37'-9"	45'-5"	43'-6"	40'-3"
		30	10	37'-3"	35'-3"	32'-11"	40'-4"	38'-2"	35'-8"	43'-4"	41'-1"	38'-4"	45'-7"	43'-10"	40'-11"
		30	15	35'-8"	33'-8"	31'-3"	38'-8"	36'-6"	33'-11"	41'-1"	39'-3"	36'-5"	42'-10"	41'-10"	38'-11"
		40	10	33'-10"	32'-6"	30'-8"	36'-8"	35'-2"	33'-3"	39'-1"	37'-10"	35'-9"	40'-10"	40'-3"	38'-2"
		40	15	33'-4"	31'-7"	29'-5"	35'-6"	34'-2"	31'-10"	37'-3"	36'-6"	34'-3"	38'-10"	38'-1"	36'-7"
		50	10	31'-4"	30'-1"	28'-7"	33'-11"	32'-7"	30'-11"	35'-9"	35'-0"	33'-3"	37'-3"	36'-10"	35'-6"
50	15	30'-11"	29'-10"	27'-11"	32'-8"	32'-2"	30'-3"	34'-3"	33'-8"	32'-6"	35'-9"	35'-2"	34'-3"		

Allowable Uniform Roof Load (in pounds per linear foot [PLF])

115% and 125% Load Duration

Use of these tables should be limited to roof slopes of 3½" per foot or less.
For steeper slopes, see pages 27-31.

Span Length	AJS® 20 Series 2½" Flange Width											
	9½" AJS® 20			11⅞" AJS® 20			14" AJS® 20			16" AJS® 20		
	Total Load		Deflect.	Total Load		Deflect.	Total Load		Deflect.	Total Load		Deflect.
	Snow (115%)	Non-Snow (125%)	L/240	Snow (115%)	Non-Snow (125%)	L/240	Snow (115%)	Non-Snow (125%)	L/240	Snow (115%)	Non-Snow (125%)	L/240
5	353	383	-	358	389	-	360	392	-	364	396	-
7	302	329	-	307	334	-	309	336	-	312	339	-
8	264	287	-	269	292	-	270	294	-	273	297	-
9	235	255	-	239	259	-	240	261	-	242	264	-
10	211	230	-	215	233	-	216	235	-	218	237	-
11	192	209	-	195	212	-	196	213	-	198	216	-
12	176	191	-	179	194	-	180	196	-	182	198	-
13	162	177	-	165	179	-	166	180	-	168	182	-
14	151	164	-	153	167	-	154	168	-	156	169	-
15	136	147	128	143	155	-	144	156	-	145	158	-
16	119	129	106	134	146	-	135	147	-	136	148	-
17	105	115	89	126	137	-	127	138	-	128	139	-
18	94	99	76	119	129	-	120	130	-	121	132	-
19	84	85	65	109	119	108	113	123	-	115	125	-
20	73	73	56	99	107	94	108	117	-	109	118	-
21	63	63	43	89	97	81	103	112	-	104	113	-
22	55	55	42	81	89	71	98	106	-	99	108	-
23	48	43	37	74	81	62	90	98	-	95	103	-
24	43	43	33	68	72	55	82	90	80	91	99	-
25				63	67	49	76	83	71	87	95	-
26				57	57	41	70	76	63	81	89	-
27				51	51	39	65	71	57	75	82	-
28				46	46	35	60	66	51	70	76	69
29				41	41	32	56	60	46	65	71	62
30							53	55	42	61	66	56
31							49	50	38	57	62	51
32							45	45	34	54	58	47
33							41	41	31	50	55	43
34										47	51	39
35										45	47	36
36										42	43	33
37										40	40	30
38												

- Total Load values are limited by shear, moment, or deflection equal to L/180.
- Deflection values (Deflect.) are limited by live load deflection equal to L/240. Check the local building code for other deflection limits that may apply.
- Both the Total Load and Deflection columns must be checked. Where a Deflection value is not shown, the Total Load value will control.

- Table values apply to either simple or multiple span joists. Span is measured center to center of the minimum required bearing length. Analyze multiple span joists with the BC CALC® software if the length of any span is less than half the length of an adjacent span.
- Slope roof joists at least ¼ inch over 12 inches to minimize ponding.
- Table values assume minimum bearing lengths without web stiffeners for joist depths of 16 inches and less.

- This table was designed to apply to a broad range of applications. It may be possible to exceed the limitations of this table by analyzing a specific application with the BC CALC® software.
- Allowable spans and loads shall be adjusted and checked for wind load as required by local building code.

Allowable Uniform Roof Load (in pounds per linear foot [PLF])

115% and 125% Load Duration

Use of these tables should be limited to roof slopes of 3½" per foot or less.
For steeper slopes, see pages 27-31.

Span Length	AJS® 190 Series 2½" Flange Width											
	9½" AJS® 190			11⅞" AJS® 190			14" AJS® 190			15" AJS® 190		
	Total Load		Deflect.	Total Load		Deflect.	Total Load		Deflect.	Total Load		Deflect.
	Snow (115%)	Non-Snow (125%)	L/240	Snow (115%)	Non-Snow (125%)	L/240	Snow (115%)	Non-Snow (125%)	L/240	Snow (115%)	Non-Snow (125%)	L/240
6	353	383	-	358	389	-	360	392	-	364	396	-
7	302	329	-	307	334	-	309	336	-	312	339	-
8	264	287	-	269	292	-	270	294	-	273	297	-
9	235	255	-	239	259	-	240	261	-	242	264	-
10	211	230	-	215	233	-	216	235	-	218	237	-
11	192	209	-	195	212	-	196	213	-	198	216	-
12	176	191	-	179	194	-	180	196	-	182	198	-
13	162	177	-	165	179	-	166	180	-	168	182	-
14	151	164	-	153	167	-	154	168	-	156	169	-
15	141	153	134	143	155	-	144	156	-	145	158	-
16	132	143	111	134	146	-	135	147	-	136	148	-
17	121	123	94	126	137	-	127	138	-	128	139	-
18	104	104	79	119	129	-	120	130	-	121	132	-
19	89	89	68	113	123	-	113	123	-	115	125	-
20	77	77	59	107	116	98	108	117	-	109	118	-
21	67	67	51	102	111	85	103	112	-	104	113	-
22	58	58	44	93	97	74	98	106	-	99	108	-
23	51	51	39	85	86	65	94	102	-	95	103	-
24	45	45	34	76	76	58	90	98	84	91	99	-
25	40	40	30	67	67	51	86	94	75	87	95	-
26				60	60	46	80	87	67	84	91	-
27				54	54	41	75	78	60	80	88	-
28				48	48	37	69	70	54	78	84	72
29				43	43	33	63	63	48	75	81	65
30							57	57	44	70	76	59
31							52	52	40	66	70	54
32							47	47	36	61	64	49
33							43	43	33	58	59	45
34							40	40	30	54	54	41
35										49	49	38
36										45	45	35
37										42	42	32
38												

- Total Load values are limited by shear, moment, or deflection equal to L/180.
- Deflection values (Deflect.) are limited by live load deflection equal to L/240. Check the local building code for other deflection limits that may apply.
- Both the Total Load and Deflection columns must be checked. Where a Deflection value is not shown, the Total Load value will control.
- Table values apply to either simple or multiple span joists. Span is measured center to center of the minimum required bearing length. Analyze multiple span joists with the BC CALC® software if the length of any span is less than half the length of an adjacent span.
- Slope roof joists at least ¼ inch over 12 inches to minimize ponding.
- Table values assume minimum bearing lengths without web stiffeners for joist depths of 16 inches and less.
- This table was designed to apply to a broad range of applications. It may be possible to exceed the limitations of this table by analyzing a specific application with the BC CALC® software.
- Allowable spans and loads shall be adjusted and checked for wind load as required by local building code.

Allowable Uniform Roof Load (in pounds per linear foot [PLF])

115% and 125% Load Duration

Use of these tables should be limited to roof slopes of 3½" per foot or less.
For steeper slopes, see pages 27-31.

Span Length	AJS® 25 Series — 9½" - 16" Depths 3/8" Web Thickness — 3½" Flange Width											
	9½" AJS® 25			11⅞" AJS® 25			14" AJS® 25			16" AJS® 25		
	Total Load		Deflect.	Total Load		Deflect.	Total Load		Deflect.	Total Load		Deflect.
	Snow (115%)	Non-Snow (125%)	L/240	Snow (115%)	Non-Snow (125%)	L/240	Snow (115%)	Non-Snow (125%)	L/240	Snow (115%)	Non-Snow (125%)	L/240
6	356	387	-	358	389	-	360	392	-	364	396	-
7	305	332	-	307	334	-	309	336	-	312	339	-
8	267	290	-	269	292	-	270	294	-	273	297	-
9	237	258	-	239	259	-	240	261	-	242	264	-
10	214	232	-	215	233	-	216	235	-	218	237	-
11	194	211	-	195	212	-	196	213	-	198	216	-
12	178	193	-	179	194	-	180	196	-	182	198	-
13	164	179	-	165	179	-	166	180	-	168	182	-
14	152	166	-	153	167	-	154	168	-	156	169	-
15	142	155	-	143	155	-	144	156	-	145	158	-
16	133	145	-	134	146	-	135	147	-	136	148	-
17	125	136	121	126	137	-	127	138	-	128	139	-
18	118	129	103	119	129	-	120	130	-	121	132	-
19	112	116	88	113	123	-	113	123	-	115	125	-
20	100	100	76	107	116	-	108	117	-	109	118	-
21	87	87	66	102	111	-	103	112	-	104	113	-
22	76	76	58	93	102	-	98	106	-	99	108	-
23	67	67	51	85	93	-	94	102	-	95	103	-
24	59	59	45	78	85	75	90	98	-	91	99	-
25	52	52	40	72	79	67	86	94	-	87	95	-
26	46	46	35	67	73	59	80	87	-	84	91	-
27	42	42	32	62	67	53	75	81	-	80	88	-
28				58	63	48	69	75	-	78	84	-
29				54	57	43	65	70	63	75	81	-
30				50	51	39	60	66	57	70	76	-
31				47	47	35	56	61	52	66	71	-
32				42	42	32	53	58	47	61	67	-
33							50	54	43	58	63	-
34							47	51	39	54	59	53
35							44	47	36	51	56	49
36							42	44	33	48	53	45
37										46	50	41
38										43	47	38

- Total Load values are limited by shear, moment, or deflection equal to L/180.
- Deflection values (Deflect.) are limited by live load deflection equal to L/240. Check the local building code for other deflection limits that may apply.
- Both the Total Load and Deflection columns must be checked. Where a Deflection value is not shown, the Total Load value will control.
- Table values apply to either simple or multiple span joists. Span is measured center to center of the minimum required bearing length. Analyze multiple span joists with the BC CALC® software if the length of any span is less than half the length of an adjacent span.
- Slope roof joists at least ¼ inch over 12 inches to minimize ponding.
- Table values assume minimum bearing lengths, no web stiffeners for joist depths of 16" and less, web stiffeners required at all bearing locations for 18" and deeper joists.
- This table was designed to apply to a broad range of applications. It may be possible to exceed the limitations of this table by analyzing a specific application with the BC CALC® software.
- Allowable spans and loads shall be adjusted and checked for wind load as required by local building code.

Allowable Uniform Roof Load (in pounds per linear foot [PLF])

115% and 125% Load Duration

Use of these tables should be limited to roof slopes of 3½" per foot or less.
For steeper slopes, see pages 27-31.

Span Length	AJS® 25 Series — Deeper Depths — 18" - 24" Depths 3/8" Web Thickness — 3½" Flange Width											
	18" AJS® 25			20" AJS® 25			22" AJS® 25			24" AJS® 25		
	Total Load		Deflect.	Total Load		Deflect.	Total Load		Deflect.	Total Load		Deflect.
	Snow (115%)	Non-Snow (125%)	L/240	Snow (115%)	Non-Snow (125%)	L/240	Snow (115%)	Non-Snow (125%)	L/240	Snow (115%)	Non-Snow (125%)	L/240
6	709	770	-	767	834	-	785	854	-	803	873	-
7	607	660	-	658	715	-	673	732	-	688	748	-
8	531	578	-	575	625	-	589	640	-	602	654	-
9	472	513	-	511	556	-	523	569	-	535	582	-
10	425	462	-	460	500	-	471	512	-	481	523	-
11	386	420	-	418	455	-	428	465	-	438	476	-
12	354	385	-	383	417	-	392	427	-	401	436	-
13	327	355	-	354	385	-	362	394	-	370	402	-
14	303	330	-	329	357	-	336	366	-	344	374	-
15	283	308	-	307	333	-	314	341	-	321	349	-
16	265	289	-	287	312	-	294	320	-	301	327	-
17	250	272	-	271	294	-	277	301	-	283	308	-
18	236	256	-	255	278	-	261	284	-	267	291	-
19	223	243	-	242	263	-	248	269	-	253	275	-
20	212	231	-	230	250	-	235	256	-	240	261	-
21	202	220	-	219	238	-	224	244	-	229	249	-
22	193	210	-	209	227	-	214	232	-	219	238	-
23	185	201	-	200	217	-	205	222	-	209	227	-
24	171	186	-	191	208	-	196	213	-	200	218	-
25	158	172	-	177	192	-	188	205	-	192	209	-
26	146	159	-	163	177	-	179	195	-	185	201	-
27	135	147	-	151	164	-	166	180	-	178	194	-
28	126	137	124	141	153	-	154	168	-	168	182	-
29	117	127	112	131	142	-	144	156	-	156	170	-
30	109	119	101	122	133	-	134	146	-	146	159	-
31	102	111	92	115	125	-	126	137	-	137	149	-
32	96	105	84	108	117	106	118	128	-	128	139	-
33	90	98	77	101	110	97	111	121	-	121	131	-
34	85	92	70	95	104	89	104	114	-	114	123	-
35	80	85	65	90	98	82	99	107	-	107	117	-
36	76	78	59	85	92	75	93	101	-	101	110	-
37	72	72	55	80	87	69	88	96	86	96	104	-
38	66	66	51	76	83	64	84	91	79	91	99	-
39	62	62	47	72	78	60	79	86	74	86	94	-
40	57	57	44	69	72	55	75	82	68	82	89	-

- Total Load values are limited by shear, moment, or deflection equal to L/180.
- Deflection values (Deflect.) are limited by live load deflection equal to L/240. Check the local building code for other deflection limits that may apply.
- Both the Total Load and Deflection columns must be checked. Where a Deflection value is not shown, the Total Load value will control.
- Table values apply to either simple or multiple span joists. Span is measured center to center of the minimum required bearing length. Analyze multiple span joists with the BC CALC® software if the length of any span is less than half the length of an adjacent span.
- Slope roof joists at least ¼ inch over 12 inches to minimize ponding.
- Table values assume: minimum bearing lengths, no web stiffeners for joist depths of 16" and less, web stiffeners required at all bearing locations for 18" and deeper joists.
- This table was designed to apply to a broad range of applications. It may be possible to exceed the limitations of this table by analyzing a specific application with the BC CALC® software.
- Allowable spans and loads shall be adjusted and checked for wind load as required by local building code.

Allowable Uniform Roof Load (in pounds per linear foot [PLF])

115% and 125% Load Duration

Use of these tables should be limited to roof slopes of 3½" per foot or less.
For steeper slopes, see pages 21-31.

AJS® 30 Series — Deeper Depths — 18" - 24" Depths 3/8" Web Thickness — 3½" Flange Width												
Span Length	18" AJS® 30			20" AJS® 30			22" AJS® 30			24" AJS® 30		
	Total Load		Deflect.	Total Load		Deflect.	Total Load		Deflect.	Total Load		Deflect.
	Snow (115%)	Non-Snow (125%)	L/240	Snow (115%)	Non-Snow (125%)	L/240	Snow (115%)	Non-Snow (125%)	L/240	Snow (115%)	Non-Snow (125%)	L/240
6	709	770	-	767	834	-	785	854	-	803	873	-
7	607	660	-	658	715	-	673	732	-	688	748	-
8	531	578	-	575	625	-	589	640	-	602	654	-
9	472	513	-	511	556	-	523	569	-	535	582	-
10	425	462	-	460	500	-	471	512	-	481	523	-
11	386	420	-	418	455	-	428	465	-	438	476	-
12	354	385	-	383	417	-	392	427	-	401	436	-
13	327	355	-	354	385	-	362	394	-	370	402	-
14	303	330	-	329	357	-	336	366	-	344	374	-
15	283	308	-	307	333	-	314	341	-	321	349	-
16	265	289	-	287	312	-	294	320	-	301	327	-
17	250	272	-	271	294	-	277	301	-	283	308	-
18	236	256	-	255	278	-	261	284	-	267	291	-
19	223	243	-	242	263	-	248	269	-	253	275	-
20	212	231	-	230	250	-	235	256	-	240	261	-
21	202	220	-	219	238	-	224	244	-	229	249	-
22	193	210	-	209	227	-	214	232	-	219	238	-
23	185	201	-	200	217	-	205	222	-	209	227	-
24	177	192	-	191	208	-	196	213	-	200	218	-
25	170	185	-	184	200	-	188	205	-	192	209	-
26	163	177	-	177	192	-	181	197	-	185	201	-
27	157	171	150	170	185	-	174	189	-	178	194	-
28	151	165	136	164	178	-	168	183	-	172	187	-
29	146	159	123	158	172	154	162	176	-	166	180	-
30	139	145	111	153	166	140	157	170	-	160	174	-
31	130	132	101	145	158	127	152	165	-	155	168	-
32	121	121	92	136	148	116	147	160	143	150	163	-
33	110	110	84	128	139	106	141	153	131	146	158	-
34	101	101	77	121	128	98	132	144	120	141	154	-
35	93	93	71	114	117	90	125	136	110	136	148	134
36	86	86	65	108	108	83	118	128	102	128	140	123
37	79	79	60	100	100	76	112	121	94	122	132	114
38	73	73	56	92	92	71	106	114	87	115	125	105
39	68	68	52	86	86	65	101	106	81	109	119	98
40	63	63	48	79	79	61	96	98	75	104	113	91

- Total Load values are limited by shear, moment, or deflection equal to L/180.
- Deflection values (Deflect.) are limited by live load deflection equal to L/240. Check the local building code for other deflection limits that may apply.
- Both the Total Load and Deflection columns must be checked. Where a Deflection value is not shown the Total Load value will control.

- Table values apply to either simple or multiple span joists. Span is measured center to center of the minimum required bearing length. Analyze multiple span joists with the B/C CALC® software if the length of any span is less than half the length of an adjacent span.
- Slope roof joists at least ¼ inch over 12 inches to minimize ponding.
- Table values assume: minimum bearing lengths, no web stiffeners for joist depths

of 1½" and less, web stiffeners required at all bearing locations for 18" and deeper joists.

- This table was designed to apply to a broad range of applications. It may be possible to exceed the limitations of this table by analyzing a specific application with the B/C CALC® software.
- Allowable spans and loads shall be adjusted and checked for wind load as required by local building code.

Joist Series	Depth [inches]	Weight [plf]	Moment [ft-lbs]	EI x 10 ⁶ [lb-in ²]	K x 10 ⁶ [lbs]	Shear [lbs]	End Reaction [lbs]				Intermediate Reaction [lbs]			
							1½" Bearing (4)		3½" Bearing		3½" Bearing		3½" Bearing	
							N, V/S(1)	V/S(2)	N, V/S(1)	WS(2)	N, V/S(1)	WS(2)	No V/S(1)	WS(2)
AJS® 20	1½	2.5	3395	232	5.2	1250	950	1240	1175	1480	2350	2450	2350	2450
	11⅝	2.8	4400	394	6.6	1570	955	1335	1215	1595	2390	2390	2390	2390
	14	3.0	5295	573	7.8	1350	960	1420	1250	1700	2430	3130	2430	3130
	16	3.3	6140	786	9.0	2100	970	1500	1285	1300	2465	3435	2465	3435
AJS® 190	1½	2.5	3895	244	5.2	1250	950	1240	1175	1480	2350	2450	2350	2450
	11⅝	2.8	5045	414	6.6	1570	955	1335	1215	1595	2390	2390	2390	2390
	14	3.1	5270	603	7.8	1350	960	1420	1250	1700	2430	3130	2430	3130
	16	3.3	7340	327	9.0	2100	970	1500	1285	1300	2465	3435	2465	3435
	18	3.9	3745	1100	12.1	3010	N/A(3)	2160	N/A(3)	2620	N/A(3)	4720	N/A(3)	4720
20	4.2	8990	1402	13.5	3240	N/A(3)	2160	N/A(3)	2980	N/A(3)	4780	N/A(3)	5110	
AJS® 25	1½	3.1	5370	322	5.3	1250	950	1240	1175	1480	2600	2350	2600	2350
	11⅝	3.4	6960	545	6.7	1570	955	1335	1215	1595	2690	3190	2690	3190
	14	3.7	3330	793	7.9	1350	960	1420	1250	1700	2770	3500	2770	3500
	16	3.9	9720	1082	9.1	2100	970	1500	1285	1300	2350	3800	2350	3300
	18	4.6	10975	1427	12.3	3010	N/A(3)	2240	N/A(3)	2620	N/A(3)	4720	N/A(3)	4720
	20	4.9	12270	1313	13.7	3240	N/A(3)	2490	N/A(3)	2980	N/A(3)	5110	N/A(3)	5110
	22	5.1	13455	2249	15.0	3470	N/A(3)	2490	N/A(3)	3150	N/A(3)	5230	N/A(3)	5505
	24	5.4	14625	2737	16.5	3690	N/A(3)	2490	N/A(3)	3320	N/A(3)	5345	N/A(3)	5900
AJS® 30	18	4.6	13905	1575	12.3	3010	N/A(3)	2240	N/A(3)	2620	N/A(3)	4720	N/A(3)	4720
	20	4.9	15540	1993	13.7	3240	N/A(3)	2490	N/A(3)	2980	N/A(3)	5110	N/A(3)	5110
	22	5.1	17040	2477	15.0	3470	N/A(3)	2490	N/A(3)	3150	N/A(3)	5230	N/A(3)	5505
	24	5.4	18525	3012	16.5	3690	N/A(3)	2490	N/A(3)	3320	N/A(3)	5345	N/A(3)	5900

NOTES:

- (1) No web stiffeners required.
- (2) Web stiffeners required.
- (3) Not applicable, web stiffeners required.
- (4) 1¼" minimum end bearing for 18" and deeper joists.
 - Moment, shear and reaction values based upon a load duration of 100% and may be adjusted for other load durations.
 - Design values listed are applicable for Allowable Stress Design (ASD).
 - No additional repetitive member increase allowed.

$$\Delta = \frac{5wL^4}{384EI} + \frac{wL^2}{K}$$

- Δ = deflection [in]
- w = uniform load [lb/in]
- L = clear span [in]
- EI = bending stiffness [lb-in²]
- K = shear deformation coefficient [lb]

BUILDING CODE EVALUATION REPORT

- ICC ESR 1144 (IBC, IRC)

AJS® Closest Allowable Nail Spacing / Diaphragm Design

Nailing Perpendicular to Glue Lines (Wide Face)

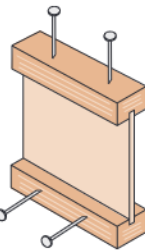

Nailing Parallel to Glue Lines (Narrow Face)

For AJS® flange nailing, lateral and withdrawal design values may be determined per the National Design Specification (NDS) for Wood Construction, using a specific gravity of 0.42.

- Nail spacing shall comply with the minimum spacing requirements prescribed by the NDS for nails installed in sawn lumber
- AJS® joists may be substituted for sawn lumber framing in horizontal wood diaphragms, as referenced in section 2306.2 of the 2012 International Building Code to Table 4.2A of ANSI/AF&PA SPPWS-2002. Reductions in diaphragm values shall be calculated per note 2 using the 0.42 specific gravity value.
- Wood screws may be substituted for nails per approval of the local building official. Consult the fastener manufacturer for diaphragm values.

BOISE CASCADE® Rimboard

BOISE CASCADE® Rimboard Product Profiles

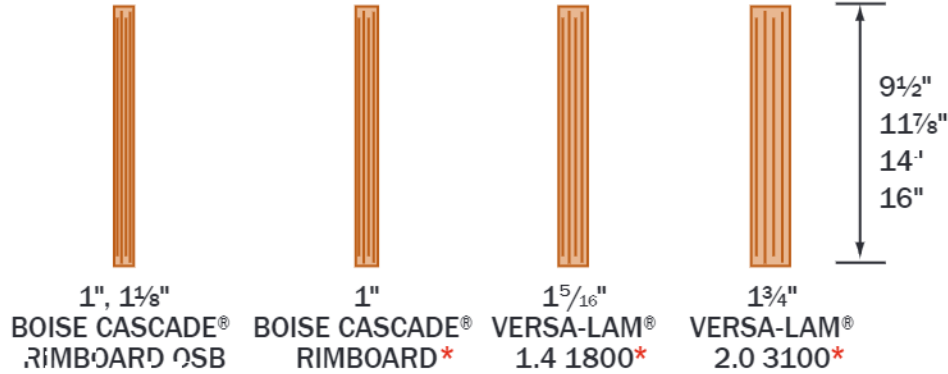

*18 – 24 inch deep rimboard are special order products, contact local supplier or Boise Cascade representative for product availability.

<p>F07 Perpendicular</p> <p>See chart for vertical load capacity.</p> <p>Connection per design professional of record's specification for shear transfer.</p>	<p>F07A Parallel</p> <p>See chart for vertical load capacity.</p> <p>Connection per design professional of record's specification for shear transfer.</p>	<p>F56</p> <p>Exterior Wall Sheathing Max. 2 5/32" thickness</p> <p>AJS® Joists Perpendicular or parallel to rim</p> <p>1/2" dia through bolts (ASTM A307 Grade 5, A508, A509 Grade 1 or 2, or higher, with washers and nuts) or 1/2" dia lag screws (full penetration) staggered</p> <p>Treated Ledger - Use only fasteners that are approved for use with corresponding wood treatment.</p> <p>BOISE CASCADE® Rimboard</p> <p>Notes:</p> <ul style="list-style-type: none"> Design of moisture control by others (only structural components shown above). Design of ledger connection per design professional of record For use of proprietary screws to attach ledger, consult screw manufacturer literature.
--	--	--

BOISE CASCADE® Rimboard Properties

Product	Vertical Load Capacity						Maximum Floor Diaphragm Lateral Capacity [lb/ft]	Specific Gravity for Lateral Nail Design	Allowable Design Values			
	Uniform [plf]			Point [lb]					Flexural Stress [lb/in ²]	Modulus of Elasticity [lb/in ²]	Horizontal Shear [lb/in ²]	Compression to Grain [lb/in ²]
16 Depth & Less	18 & 20 Depth & Less	22" & 24" Depth & Less	16 Depth & Less	18" & 20 Depth & Less	22" & 24 Depth & Less							
1" BOISE CASCADE® RIMBOARD OSB (2) & 1" BOISE CASCADE® RIMBOARD OSB (2)	3,000	1,650	1,650	3,500	3,500	3,500	180	0	Limited span capabilities, see note 2			
1 1/8" BOISE CASCADE® RIMBOARD OSB (2)	4,400	3,000	3,000	3,500	3,500	3,500	180	0.5	Limited span capabilities, see note 2			
1 5/16" VERSA-LAM® 1.4 1800 (1)	6,000	4,450	—	4,450	4,450	—	Permitted per building code for all nominal 2" thick framing blocked and unblocked diaphragms (4" nail spacing & greater)	0.5	1,800	1,400,000	225	525
1 3/4" VERSA-LAM® 2.0 3100 (1)	5,700	4,300	—	4,300	3,000	—	Permitted per building code for all nominal 2" thick framing blocked and unblocked diaphragms (4" nail spacing & greater)	0.5	2,800	2,000,000	285	750

Product	Closest Allowable Nail Spacing - Narrow Face [in]					
	8d Box	8d Common	10d & 12d Box	16d Box	10d, 12d Common & 16d Sinker	16d Common
1" BOISE CASCADE® RIMBOARD (2)	3	3	-	-	-	-
1" or 1 1/8" BOISE CASCADE® RIMBOARD OSB (2)	3	3	See note 2 for nailing information			
1 5/16" VERSA-LAM® 1.4 1800 (1)	3	3	3	3	4	6
1 3/4" VERSA-LAM® 2.0 3100 (1)	2	3	3	3	4	6

Notes

- Per ICC ESR-1040.
- See Performance Rated Rim Boards, APA EWS #WC45K for further product information.
- Not all products and depths may be available, check with Boise Cascade representative for product availability.

An Introduction to VERSA-LAM® Products



When you specify VERSA-LAM® laminated veneer headers/beams, you are building quality into your design. They are excellent as floor and roof framing supports or as headers for doors, windows and garage doors and columns.

Because they have no camber, VERSA-LAM® LVL products provide flatter, quieter floors, and consequently, the builder can expect happier customers with significantly fewer call backs.

VERSA-LAM® Beam Architectural Specifications

Scope: This work includes the complete furnishing and installation of all VERSA-LAM® beams as shown on the drawings, herein specified and necessary to complete the work.

Materials: Southern Pine or Douglas fir veneers, laminated in a press with all grain parallel with the length of the member. Glues used in lamination are phenol formaldehyde and isocyanate exterior-type adhesives which comply with ASTM D2559.

Design: VERSA-LAM® beams shall be sized and detailed to fit the dimensions and loads indicated on the plans. All designs shall be in accordance with allowable values developed in accordance with ASTM D5456 and listed in the governing

code evaluation service's report and section properties based upon standard engineering principles. Verification of design of the VERSA-LAM® beams by complete calculations shall be available upon request.

Drawings: Additional drawings showing layout and detail necessary for determining fit and placement in the buildings are (are not) to be provided by the supplier.

Fabrication: VERSA-LAM® beams shall be manufactured in a plant evaluated for fabrication by the governing code evaluation service and under the supervision of a third-party inspection agency listed by the corresponding evaluation service.

Storage and Installation: VERSA-LAM® beams, if stored prior to erection shall be stored on stickers spaced a maximum of 15 ft. apart. Beams shall be stored on a dry, level surface and protected from the weather. They shall be handled with care so they are not damaged.

VERSA-LAM® beams are to be installed in accordance with the plans and Boise Cascade EWP's Installation Guide. Temporary construction loads which cause stresses beyond design limits are not permitted. Erection bracing shall be provided to assure adequate lateral support for the individual beams and the entire system until the sheathing material has been applied.

Codes: VERSA-LAM® beams shall be evaluated by a model code evaluation service.

Allowable Holes in VERSA-LAM® Beams

Notes

1. Square and rectangular holes are not permitted.
2. Round holes may be drilled or cut with a hole saw anywhere within the shaded area of the beam.
3. The horizontal distance between adjacent holes must be at least two times the size of the larger hole.
4. Do not drill more than three access holes in any four foot long section of beam.
5. The maximum round hole diameter permitted is:

Beam Depth	Max. Hole Diameter
5½"	¾"
7¼"	1"
9¼" and greater	2"

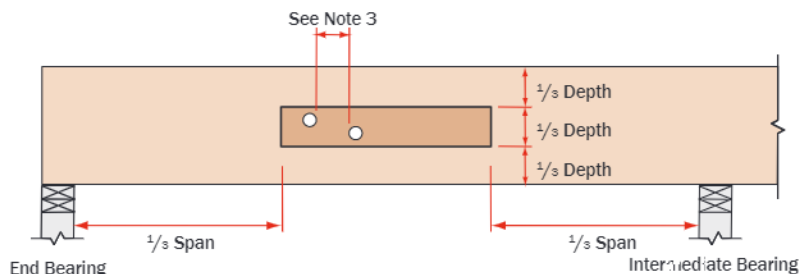

6. These limitations apply to holes drilled for plumbing or wiring access only. The size and location of holes drilled for fasteners are governed by the provisions of the *National Design Specification® for Wood Construction*.
7. Beams deflect under load. Size holes to provide clearance where required.
8. This hole chart is valid for beams supporting uniform load only. For beams supporting concentrated loads or for beams with larger holes, contact Boise Cascade EWP Engineering.

B01

B02

B03

B04

B06

B07

B08

B09

VERSA-LAM® Installation Notes

- Minimum of 1/2" air space between beam and wall pocket or adequate barrier must be provided between beam and concrete/masonry.
- Adequate bearing shall be provided. If not shown on plans, please refer to load tables in your region's Specifier Guide.
- VERSA-LAM® beams are intended for interior applications only and should be kept as dry as possible during construction.
- Continuous lateral support of top of beams shall be provided (side or top bearing framing).

Multiple Member Connectors

Side-Loaded Applications								
Number of Members	Maximum Uniform Side Load [plf]							
	Nailed		1/2" Dia. Through Bolt(s)			3/4" Dia. Through Bolt(s)		
	3 rows 16d Sinks @ 12" o.c.	4 rows 16d Sinks @ 12" o.c.	2 rows @ 24" o.c. staggered	2 rows @ 12" o.c. staggered	2 rows @ 6" o.c. staggered	2 rows @ 24" o.c. staggered	2 rows @ 12" o.c. staggered	2 rows @ 6" o.c. staggered
1 1/4" VERSA-LAM® (depths of 16" and less)								
2	470	705	505	1010	2020	600	1120	2245
3(2)	350	525	375	755	1515	20	840	1685
4(3)	use bolt schedule	335	505	1010	1345	370	745	1495
3/2" VERSA-LAM®								
2(1)	use bolt schedule	855	1715	N/A	1125	2250	N/A	N/A
1 3/4" VERSA-LAM® (depths of 24")								
Number of Members	Nailed		1/2" Dia. Through Bolt(s)			3/4" Dia. Through Bolt(s)		
	3 rows 16d Sinks @ 12" o.c.	4 rows 16d Sinks @ 12" o.c.	3 rows @ 24" o.c. staggered	3 rows @ 18" o.c. staggered	3 rows @ 12" o.c. staggered	3 rows @ 24" o.c. staggered	3 rows @ 18" o.c. staggered	3 rows @ 12" o.c. staggered
	2	705	940	755	1010	1515	840	1120
3(2)	525	705	565	755	1135	630	840	1260
4(3)	use bolt schedule	505	670	1010	560	745	1120	1120

1. Design values apply to connections bolts that conform to ANSI/AISC standards B18.21-1981 (ASTM A307) Grades A&B. SEE J-29 Grades 1 or 2, or use equivalent washers, no less than 1/4" and not cut or altered between the wood and the bolt head and between the wood and the nut. The distance from the edge of the beam to the bolt hole must be at least:
 2. For 1/2" bolts and 2 1/2" or 3" bolts. Bolt holes shall be the same diameter as the bolt.
 2. The nail schedules shown apply to both sides of a 3-member beam.
 3. 7" wide beams must be top-loaded or loaded from both sides (lesser side shall be no less than 25% of opposite side).

Top-Loaded Applications			
For top-loaded beams and beams with side loads with less than those shown:			
Plies	Depth	Nailing	Maximum Uniform Load on One Side
(2) 1 1/4" plies	Depths 11 7/8" & less	2 rows 16d box/sinker nails @ 12" o.c.	400 plf
	Depths 14" - 16"	3 rows 16d box/sinker nails @ 12" o.c.	600 plf
	Depth = 24"	3 rows 16d box/sinker nails @ 12" o.c.	800 plf
(3) 1 1/4" plies	Depths 11 7/8" & less	2 rows 16d box/sinker nails @ 12" o.c. both sides	300 plf
	Depths 14" - 18"	3 rows 16d box/sinker nails @ 12" o.c. both sides	600 plf
	Depth = 24"	3 rows 16d box/sinker nails @ 12" o.c. both sides	800 plf
(1) 1 3/4" plies	Depths 18" & less	2 rows 1/2" bolts @ 24" o.c., staggered	335 plf
	Depth = 24"	3 rows 1/2" bolts @ 24" o.c., staggered every 8"	505 plf
(2) 3/2" plies	Depths 18" & less	2 rows 1/2" bolts @ 24" o.c., staggered	855 plf
	Depth 20" - 24"	3 rows 1/2" bolts @ 24" o.c., staggered every 8"	1285 plf

1. Beams wider than 7" must be designed by the engineer of record.
2. All values in these tables may be increased by 5% for snow-load roofs and by 25% for non-snow load roofs where the building code allows.
3. Use a allowable load table of BC CALC® software to size beams.
4. An equivalent specific gravity of 0.5 may be used when designing specific connections with VERSA-LAM®.
5. Connection values are based upon the 2012 NDS.
6. **FastenMaster Tru-Lok, Strong-Tie SCL and SDW, and U, P, WS rework, may also be used to connect multiple member VERSA-LAM® beams, contact Boise Cascade EWP Engineering for further information.**

Designing Connections for Multiple VERSA-LAM® Members

When using multiple ply VERSA-LAM® beams to create a wider member, the connection of the plies is as critical as determining the beam size. When side loaded beams are not connected properly, the inside plies do not support their share of the load and thus the load-carrying capacity of the full member decreases significantly. The following is an example of how to size and connect a multiple-ply VERSA-LAM® floor beam.

Given: Beam shown below is supporting residential floor load (40 psf live load + 10 psf dead load) and is spanning 16'-0". Beam depth is limited to 14".

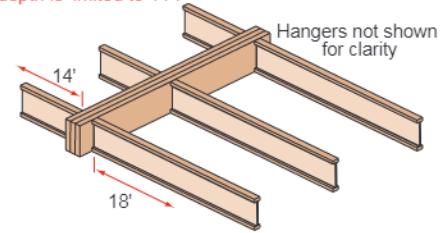

Find: A minimum 1 1/4" ply VERSA-LAM® that is adequate to support the design loads and the member's proper connection schedule

1. Calculate the tributary width that beam is supporting:

$$14' + 2 \times 18' = 50'$$
2. Use PLF tables on page 40 of EWC or BC CALC® to size beam. A Triple VERSA-LAM® 2.0 3100 1 1/4" x 14" is found to adequately support the design loads.
3. Calculate the maximum plf load from one side (the right side in this case):

$$\text{Max. Side Load} = (18' / 2) \times (40 + 10 \text{ psf}) = 450 \text{ plf}$$
4. Refer to the Multiple Member Connection Table, Side-Loaded Applications, 1 1/4" VERSA-LAM®, 3 members.
5. The proper connection schedule must have a capacity greater than the max. side load:

Nailed: 3 rows 16d sinkers @ 12" o.c.: 525 plf is greater than 450 plf OK

Bolts: 1/2" diameter 2 rows @ 12" staggered: 755 plf is greater than 450 plf OK

Heavy Storage: 250 psf Live Load / 25 psf Dead Load

O.C. Spacing	1½" VERSA-LAM® 1.7 2650				1½" VERSA-LAM® 1.7 2650					1¾" VERSA-LAM® 2.0 3100			
	7¼	9¼	11¼	14	7¼	9½	11⅞	14	16	9½	11⅞	14	16
12"	7'-8"	9'-10"	12'-0"	15'-0"	8'-1"	10'-8"	13'-4"	15'-3"	18'-1"	11'-3"	14'-1"	16'-8"	19'-1"
16"	7'-0"	8'-11"	10'-11"	13'-7"	7'-4"	9'-8"	12'-1"	14'-4"	16'-5"	10'-3"	12'-10"	15'-1"	17'-4"
19.2"	5'-7"	8'-5"	10'-3"	12'-9"	6'-11"	9'-1"	11'-5"	13'-6"	15'-5"	9'-7"	12'-0"	14'-3"	16'-3"
24"	5'-10"	7'-6"	9'-1"	11'-4"	6'-5"	8'-5"	10'-7"	12'-6"	14'-3"	8'-11"	11'-2"	13'-2"	15'-1"

- Loading based upon Heavy Storage - Table 1607.1 of 2009/2012 International Building Code.
- Spans limited by allowable moment and reaction values, total load deflection of L/240. Live load deflection limited to L/600 with 50 psf, L/360 with 250 psf.
- Table values represent the most restrictive of simple or multiple span applications.
- Table values are the maximum allowable clear distance between supports.
- Table values assume web stiffeners at each bearing location, minimum 2¼" end bearing.
- This table was designed to apply to a broad range of applications. It may be possible to exceed the limitations of this table by analyzing a specific application with the BC CALC® sizing software.
- Table based upon bearing supports of 2x6 framing.
- **Bold spans indicate applications where bearing wider than 2x6 framing may be needed at intermediate supports.**

Light Storage: 125 psf Live Load / 25 psf Dead Load

O.C. Spacing	1½" VERSA-LAM® 1.7 2650				1¾" VERSA-LAM® 1.7 2650					1¾" VERSA-LAM® 2.0 3100			
	7¼	9¼	11¼	14	7¼	9½	11⅞	14	16	9½	11⅞	14	16
12"	9'-9"	12'-5"	15'-2"	18'-11"	10'-3"	13'-6"	16'-10"	19'-11"	22'-9"	14'-3"	17'-10"	21'-0"	24'-1"
16"	8'-10"	11'-3"	13'-9"	17'-2"	9'-3"	12'-3"	15'-4"	18'-1"	20'-8"	12'-11"	16'-2"	19'-1"	21'-10"
19.2"	8'-3"	10'-7"	12'-11"	16'-2"	8'-9"	11'-6"	14'-5"	17'-0"	19'-5"	12'-2"	15'-2"	17'-11"	20'-6"
24"	7'-8"	9'-10"	12'-0"	15'-0"	8'-1"	10'-8"	13'-4"	15'-9"	18'-1"	11'-3"	14'-1"	16'-8"	19'-1"

- Loading based upon Light Storage - Table 1607.1 of 2009/2012 International Building Code.
- Spans limited by allowable moment and reaction values, total load deflection of L/240. Live load deflection limited to L/600 with 50 psf, L/360 with 125 psf.
- Table values represent the most restrictive of simple or multiple span applications.
- Table values are the maximum allowable clear distance between supports.
- Table values assume web stiffeners at each bearing location, minimum 2¼" end bearing.
- This table was designed to apply to a broad range of applications. It may be possible to exceed the limitations of this table by analyzing a specific application with the BC CALC® sizing software.
- Table based upon bearing supports of 2x6 framing.
- **Bold spans indicate applications where bearing wider than 2x6 framing may be needed at intermediate supports.**

VERSA-LAM® Floor Load Tables

VERSA-LAM® 2.0 3100 (100% Load Duration)

KEY TO TABLE	Top Figure	- Allowable Total Load [plf]
	Middle Figure	- Allowable Live Load [plf]
	Bottom Figures	- Minimum Required Bearing Length at End / Intermediate Supports [inche-]

Span [ft]	1½" VERSA-LAM® 2.0 3100				Double Ply 1½" VERSA-LAM® 2.0 3100 or ½" VERSA-LAM 2.0 3100								Triple Ply 1½" VERSA-LAM® 2.0 3100 or 5/8" VERSA-LAM 2.0 3100								Quadruple Ply 1½" VERSA-LAM® 2.0 3100 or 1" VERSA-LAM 2.0 3100					
	7/4"	3½"	1:7/8"	14"	7/4"	9½"	1:7/8"	14"	16"	18"	24"	9½"	11½"	14"	16"	18"	24"	4"	1:7/8"	14"	16"	18"	24"	4"		
6	763	1063	1424	1795	1525	2126	2949	3590	4377	5232	5226	4109	4273	5374	6570	7843	7845	7833	5697	7179	8773	10463	10459	10451		
	762	-	-	-	1525	-	-	-	-	-	-	-	-	-	-	-	-	-	-	-	-	-	-	-		
8	3/4	2.4/6.1	3.3/7.2	4.1/10.3	1.8/4.4	2.4/6.1	3.3/7.2	4.1/10.3	5/12.6	6/15	6/15	2.4/6.1	3.3/7.2	4.1/10.3	5/12.6	6/15	6/15	6/15	3.3/7.2	4.1/10.3	5/12.6	6/15	6/15	6/15		
	479	746	979	1237	957	1492	1957	2414	2876	3432	3913	2237	2936	3622	4328	5133	5876	5870	3914	4829	5771	6833	7834	7826		
10	322	724	-	-	643	1447	-	-	-	-	-	2171	-	-	-	-	-	-	-	-	-	-	-	-		
	1.5/3.7	2.3/5.7	3/7.5	3.7/9.3	1.5/3.7	2.3/5.7	3/7.5	3.7/9.3	4.4/11.1	5.2/13	6/15	2.3/5.7	3/7.5	3.7/9.3	4.4/11.1	5.2/13	6/15	6/15	3/7.5	3.7/9.3	4.4/11.1	5.2/13	6/15	6/15		
12	243	551	745	909	487	1102	14.9	18.7	2148	2532	3126	1653	2234	2726	3222	3753	4322	4322	2978	3635	4296	5033	5763	6251		
	165	370	724	-	329	741	1447	-	-	-	-	1111	2171	-	-	-	-	-	2894	-	-	-	-	-		
14	182	413	665	808	364	825	1330	1617	1934	2239	2839	1238	1995	2425	2856	3313	3830	4259	2659	3233	3837	4417	5067	5679		
	124	278	544	-	247	557	1087	-	-	-	-	335	1631	-	-	-	-	-	2175	-	-	-	-	-		
16	1.5/3	1.7/4.4	2.8/7.1	3.4/8.5	1.5/3	1.7/4.4	2.8/7.1	3.4/8.5	4/10.1	4.7/11.7	6/15	1.7/4.4	2.8/7.1	3.4/8.5	4/10.1	4.7/11.7	6/15	6/15	2.8/7.1	3.4/8.5	4/10.1	4.7/11.7	6/15	6/15		
	139	317	585	728	279	634	1173	1456	1739	1977	2631	950	1755	2134	2564	2965	3390	3931	2340	2912	3418	3953	4519	5231		
18	95	214	419	-	191	429	337	1372	-	-	-	643	1256	2053	-	-	-	-	1675	2745	-	-	-	-		
	1.5/3	1.5/3.7	2.7/6.8	3.4/8.4	1.5/3	1.5/3.7	2.7/6.8	3.4/8.4	3.9/9.9	4.6/11.4	6/15	1.5/3.7	2.7/6.8	3.4/8.4	3.9/9.9	4.6/11.4	6/15	6/15	2.7/6.8	3.4/8.4	3.9/9.9	4.6/11.4	6/15	6/15		
20	109	248	-	662	217	496	976	1324	1550	1739	2399	744	1464	1976	2326	2633	3059	3593	1952	2647	3131	3577	4078	4797		
	75	169	329	540	150	337	659	1079	-	-	-	536	978	1619	-	-	-	-	1317	2159	-	-	-	-		
22	1.5/3	1.5/3.1	2.4/6.1	3.3/7.3	1.5/3	1.5/3.1	2.4/6.1	3.3/7.3	3.9/9.7	4.5/11.2	6/15	1.5/3.1	2.4/6.1	3.3/7.3	3.9/9.7	4.5/11.2	6/15	6/15	2.4/6.1	3.3/7.3	3.9/9.7	4.5/11.2	6/15	6/15		
	6	198	390	585	173	395	779	1171	1418	1633	2226	593	1169	1756	2123	2449	2766	3338	1558	2342	2837	3265	3715	4451		
24	63	135	264	432	120	270	527	-	1290	-	-	435	791	1296	1935	-	-	-	1055	1728	2580	-	-	-		
	1.5/3	1.5/3	2.1/5.3	3.2/7.9	1.5/3	1.5/3	2.1/5.3	3.2/7.9	3.8/9.6	4.4/11.1	6/15	1.5/3	2.1/5.3	3.2/7.9	3.8/9.6	4.4/11.1	6/15	6/15	2.1/5.3	3.2/7.9	3.8/9.6	4.4/11.1	6/15	6/15		
26	73	160	316	509	139	321	631	1018	1337	1532	2076	479	947	1527	1960	2253	2558	3113	1262	2036	2614	3033	3410	4151		
	49	110	214	351	90	220	429	733	1049	1493	-	329	643	1054	1573	2240	-	-	858	1435	2098	2987	-	-		
28	1.5/3	1.5/3	1.8/4.6	2.9/7.4	1.5/3	1.5/3	1.8/4.6	2.9/7.4	3.8/9.5	4.3/10.9	6/15	1.5/3	1.8/4.6	2.9/7.4	3.8/9.5	4.3/10.9	6/15	6/15	1.8/4.6	2.9/7.4	3.8/9.5	4.3/10.9	6/15	6/15		
	57	131	259	427	113	262	518	854	1151	1390	1944	393	777	1261	1727	2005	2364	2917	1036	1733	2333	2730	3151	3839		
30	43	93	177	279	83	191	353	579	-	1230	-	271	531	894	1341	1731	2051	2552	720	1191	1708	2263	2735	3432		
	1.5/3	1.5/3	1.6/4	2.6/6.6	1.5/3	1.5/3	1.6/4	2.6/6.6	3.6/9.9	4.3/10.7	6/15	1.5/3	1.6/4	2.6/6.6	3.6/9.9	4.3/10.7	6/15	6/15	1.6/4	2.6/6.6	3.6/9.9	4.3/10.7	6/15	6/15		
32	108	215	355	93	217	430	710	1013	1274	1826	-	325	645	1065	1527	1911	2196	2739	860	1420	2036	2547	2929	3652		
	75	147	241	67	151	295	433	720	1026	-	226	442	724	1071	1539	2111	-	-	509	965	1441	2052	2814	-		
34	1.5/3	1.5/3.6	2.3/5.9	1.5/3	1.5/3	1.5/3.6	2.3/5.9	3.3/8.4	4.2/10.5	6/15	1.5/3	1.5/3.6	2.3/5.9	3.3/8.4	4.2/10.5	6/15	6/15	1.5/3.6	2.3/5.9	3.3/8.4	4.2/10.5	6/15	6/15			
	90	180	298	77	181	360	596	894	1134	1731	271	546	894	1341	1731	2051	2552	720	1191	1708	2263	2735	3432			
36	108	215	355	93	217	430	710	1013	1274	1826	-	325	645	1065	1527	1911	2196	2739	860	1420	2036	2547	2929	3652		
	75	147	241	67	151	295	433	720	1026	-	226	442	724	1071	1539	2111	-	-	509	965	1441	2052	2814	-		
38	1.5/3	1.5/3.6	2.3/5.9	1.5/3	1.5/3	1.5/3.6	2.3/5.9	3.3/8.4	4.2/10.5	6/15	1.5/3	1.5/3.6	2.3/5.9	3.3/8.4	4.2/10.5	6/15	6/15	1.5/3.6	2.3/5.9	3.3/8.4	4.2/10.5	6/15	6/15			
	90	180	298	77	181	360	596	894	1134	1731	271	546	894	1341	1731	2051	2552	720	1191	1708	2263	2735	3432			
40	108	215	355	93	217	430	710	1013	1274	1826	-	325	645	1065	1527	1911	2196	2739	860	1420	2036	2547	2929	3652		
	75	147	241	67	151	295	433	720	1026	-	226	442	724	1071	1539	2111	-	-	509	965	1441	2052	2814	-		
42	1.5/3	1.5/3.6	2.3/5.9	1.5/3	1.5/3	1.5/3.6	2.3/5.9	3.3/8.4	4.2/10.5	6/15	1.5/3	1.5/3.6	2.3/5.9	3.3/8.4	4.2/10.5	6/15	6/15	1.5/3.6	2.3/5.9	3.3/8.4	4.2/10.5	6/15	6/15			
	90	180	298	77	181	360	596	894	1134	1731	271	546	894	1341	1731	2051	2552	720	1191	1708	2263	2735	3432			
44	108	215	355	93	217	430	710	1013	1274	1826	-	325	645	1065	1527	1911	2196	2739	860	1420	2036	2547	2929	3652		
	75	147	241	67	151	295	433	720	1026	-	226	442	724	1071	1539	2111	-	-	509	965	1441	2052	2814	-		
46	1.5/3	1.5/3.6	2.3/5.9	1.5/3	1.5/3	1.5/3.6	2.3/5.9	3.3/8.4	4.2/10.5	6/15	1.5/3	1.5/3.6	2.3/5.9	3.3/8.4	4.2/10.5	6/15	6/15	1.5/3.6	2.3/5.9	3.3/8.4	4.2/10.5	6/15	6/15			
	90	180	298	77	181	360	596	894	1134	1731	271	546	894	1341	1731	2051	2552	720	1191	1708	2263	2735	3432			
48	108	215	355	93	217	430	710	1013	1274	1826	-	325	645	1065	1527	1911	2196	2739	860	1420	2036	2547	2929	3652		
	75	147	241	67	151	295	433	720	1026	-	226	442	724	1071	1539	2111	-	-	509	965	1441	2052	2814	-		
50	1.5/3	1.5/3.6	2.3/5.9	1.5/3	1.5/3	1.5/3.6	2.3/5.9	3.3/8.4	4.2/10.5	6/15	1.5/3	1.5/3.6	2.3/5.9	3.3/8.4	4.2/10.5	6/15	6/15	1.5/3.6	2.3/5.9	3.3/8.4	4.2/10.5	6/15	6/15			
	90	180	298	77	181	360	596	894	1134	1731	271	546	894	1341	1731	2051	2552	720	1191	1708	2263	2735	3432			
52	108	215	355	93	217	430	710	1013	1274	1826	-	325	645	1065	1527	1911	2196	2739	860	1420	2036	2547	2929	3652		
	75	147	241	67	151	295	433	720	1026	-	226	442	724	1071												

VERSA-LAM® 2.0 3100 (115% Load Duration)

KEY TO TABLE	Top Figure	- Allowable Total Load [plf]
	Middle Figure	- Allowable Live Load [plf]
	Bottom Figures	Minimum Required Bearing Length at End / Intermediate Supports [inches]

Span [ft]	1½" VERSA-LAM® 2.0 3100				Double Ply 1½" VERSA-LAM® 2.0 3100 or 3½" VERSA-LAM 2.0 3100								Triple Ply 1½" VERSA-LAM® 2.0 3100 or 5½" VERSA-LAM 2.0 3100								Quadruple Ply 1½" VERSA-LAM® 2.0 3100 or 7" VERSA-LAM 2.0 3100								
	7¼"	9½"	11½"	14"	7¼"	9½"	11½"	14"	16"	18"	24"	9½"	11½"	14"	16"	18"	24"	11½"	14"	16"	18"	24"	11½"	14"	16"	18"	24"		
6	878	223	639	2065	1735	2140	3278	4130	5047	5232	5220	3669	4911	5195	7570	848	845	7838	3566	8260	1009	10423	10159	13451					
	2/5	2.8/7	3.8/9.4	4.7/11.8	2/5	2.8/7	3.8/9.4	4.7/11.8	5.8/14.5	6/5	6/15	2.8/7	3.8/9.4	4.7/11.8	5.8/14.5	6/5	6/15	3.8/9.4	4.7/11.8	5.8/14.5	6/5	6/15	3.8/9.4	4.7/11.8	5.8/14.5	6/5	6/15		
8	598	858	1126	1489	1197	1717	2252	2779	3421	3915	3913	2575	3379	4168	4981	5872	5876	5870	4515	5558	6642	7829	7831	7826					
	4/2				9/5																								
10	326	577	857	1046	551	1274	1714	2092	272	2880	3120	1912	2571	3138	3739	4220	4695	388	3429	4184	4945	5759	5259	5251					
	247	556			.94	1111						1867																	
11	244	526	765	971	477	1052	1530	1861	2192	2543	2839	1577	2290	2792	3288	3814	4265	4259	3062	3723	4583	5085	5687	5679					
	1.5/	2.2/5.6	3.2/8.1	3.9/9.8	.5/	2.2/5.6	3.2/8.1	3.9/9.8	4.6/11.6	5.4/13.4	6/15	2.2/5.6	3.2/8.1	3.9/9.8	4.6/11.6	5.4/13.4	6/15	6/15	3.2/8.1	3.9/9.8	4.6/11.6	5.4/13.4	6/15	6/15	3.2/8.1	3.9/9.8	4.6/11.6	5.4/13.4	
12	167	424	674	878	374	810	1347	1670	1968	2276	2621	1272	2021	2514	2952	3414	3930	3931	2694	3303	3936	4552	5203	5201					
	1.13	2.2	3.2	4.2	2.6	6.4	10.6					9.6	18.8						25.12										
13	146	322	573	762	292	665	1146	1524	1785	2060	2399	997	1719	2287	2678	3089	3522	3598	2292	3049	3571	4119	4696	4797					
	1.12	2.53	3.94		2.25	5.00	9.28					7.59	14.82						19.76										
14	116	265	493	674	233	510	917	1349	1634	1880	2226	790	1400	2023	2400	2821	3208	3338	1973	2697	3267	3761	4278	4401					
	9.0	203	390	530	1.0	4.05	7.91	12.96				6.08	10.7	19.44					15.82	25.90									
15	94	215	423	576	188	429	816	1173	1505	1730	2070	611	1268	1759	2258	2595	2946	3113	1691	2346	3011	3559	3928	4101					
	7.3	165	322	527	1.40	3.29	6.43	10.54				.94	9.65	15.81					1.86	21.8									
16	77	176	347	515	153	352	695	1029	1327	1601	1944	528	1042	1544	1990	2302	2723	2917	1389	2058	2653	3202	3630	3889					
	6.0	1.16	2.65		1.4	1.21	2.71	5.0	8.8	12.96			1.07	7.95	11.03	19.4			10.60	17.37	25.90								
17	63	146	299	455	127	292	577	910	1173	1468	1829	418	816	1365	1760	2201	2531	2740	1154	1820	246	2935	3374	3657					
	5.3	1.1	2.21	3.62	1.01	2.25	4.42	7.24	10.81			1.9	6.63	10.86	16.21				8.1	14.48	21.61								
18	53	122	242	399	106	244	479	799	1045	1307	1720	367	720	1198	1567	1961	2364	2588	968	1598	2089	2614	3151	3351					
	4.2	95	166	305	85	191	372	610	910	1296			2.66	5.58	9.15	13.66	19.44		7.44	12.20	18.21	25.90							
19	43	103	205	319	89	200	400	677	916	1171	1634	310	615	1016	1404	1757	2147	2350	820	1354	1872	2342	2862	3267					
	3.5	1.5/3.8	2.5/6.2		.5/	.5/	1.5/3.8	2.5/6.2	3.4/8.6	4.3/10.8	6/15	1.5/	1.5/3.8	2.5/6.2	3.4/8.6	4.3/10.8	6/15	6/15	1.5/3.8	2.5/6.2	3.4/8.6	4.3/10.8	6/15	6/15	1.5/3.8	2.5/6.2	3.4/8.6	4.3/10.8	
20	88	175	349	515	176	350	690	1173	1505	1730	2070	611	1268	1759	2258	2595	2946	3113	1691	2346	3011	3559	3928	4101					
	6.9	1.6	3.22	5.15	1.9	2.71	4.45	7.24	10.81			1.9	6.63	10.86	16.21				8.1	14.48	21.61								
22	65	130	260	390	140	280	420	630	840	1050	1400	420	630	840	1050	1400	1800	2100	1050	1500	2100	2700	3300	3600					
	5.2	1.02	1.67		1.04	2.04	3.4	4.99	7.0			1.5/	3.00	5.01	7.48	10.65	15.61		1.08	3.8	9.97	1.20	19.48						
24	99	164	328	492	198	396	792	1188	1584	2016	2688	872	1744	2616	3488	4360	5232	5712	1440	2880	4320	5760	7200	8100					
	7.9	1.29			1.5/	1.5/	1.5/3.9	2.3/5.9	3.3/8.3	5.9/14.7	1.5/	1.5/	1.5/3.9	2.3/5.9	3.3/8.3	5.9/14.7	1.5/	1.5/3.9	2.3/5.9	3.3/8.3	5.9/14.7	1.5/	1.5/3.9	2.3/5.9	3.3/8.3	5.9/14.7			
26	76	128	256	384	152	304	608	912	1216	1620	2160	768	1536	2304	3072	3840	4608	5040	1280	2560	3840	5120	6400	7200					
	6.2	1.01			1.5/	1.5/	1.5/3.3	2/5	2.8/7.1	5.4/13.5	1.5/	1.5/	1.5/3.3	2/5	2.8/7.1	5.4/13.5	1.5/	1.5/3.3	2/5	2.8/7.1	5.4/13.5	1.5/	1.5/3.3	2/5	2.8/7.1	5.4/13.5			
28	60	101	202	303	120	202	404	606	808	1010	1344	606	1212	1818	2424	3030	3636	3960	1212	2424	3636	4848	6060	6831					
	4.9	81			1.5/	1.5/	1.5/	1.7/4.3	2.1/6.1	5/12.6	1.5/	1.5/	1.5/	1.7/4.3	2.1/6.1	5/12.6	1.5/	1.5/	1.5/	1.7/4.3	2.1/6.1	5/12.6	1.5/	1.5/	1.5/	1.7/4.3	2.1/6.1		
30	48	81	162	243	96	162	324	486	648	864	1152	486	972	1458	1944	2592	3180	3420	972	1944	2916	3888	4860	5496					
	3.8	1.5/			1.5/	1.5/	1.5/3.7	2.1/5.3	4.7/11.7	1.5/	1.5/	1.5/	1.5/3.7	2.1/5.3	4.7/11.7	1.5/	1.5/	1.5/	1.5/3.7	2.1/5.3	4.7/11.7	1.5/	1.5/	1.5/	1.5/3.7	2.1/5.3			

- Total Load values are limited by shear, moment or deflection equal to L/180. Total Load values are the capacity of the beam in addition to its own weight.
- Live Load values are limited by deflection equal to L/240. Check the local building code for other deflection limits that may apply.
- Where a Live Load value is not shown, the Total Load value will control.
- Table values represent the most restrictive of simple or multiple span applications. Span is measured center to center of the supports. Analyze multiple span beams with the BC CALC® software if the length of any span is less than half the length of an adjacent span.
- Table values assume that lateral support is provided at each support and continuously along the top edge and applicable compression edges of the beam.
- Table values for minimum Required Bearing Lengths are based on the allowable compression design value perpendicular to grain for the beam and the Total Load value shown. Other design considerations such as a weaker support material, may warrant longer bearing lengths. Table values assume that support is provided across the full width of the beam.
- For 2-ply 3-ply or 4-ply beams, double, triple or quadruple Allowable Total Load and Allowable Live Load values. Minimum Required Bearing Lengths remain the same for any number of plies.
- 1½ inch members deeper than 14 inches are to be used as multiple-member beam only.
- This table was designed to apply to a broad range of applications. It may be possible to exceed the limitations of this table by analyzing a specific application with the BC CALC® software.

VERSA-LAM® Roof Load Tables

VERSA-LAM® 2.0 3100 (125% Load Duration)

KEY TO TABLE	Top Figure - Allowable Total Load [plf]
	Middle Figure - Allowable Live Load [plf]
	Bottom Figures - Minimum Required Bearing Length at End / Intermediate Supports [inches]

Span [ft]	1½" VERSA-LAM® 2.0 3100				Double Ply 1½" VERSA-LAM® 2.0 3100 or 3½" VERSA-LAM 2.0 3100								Triple Ply 1½" VERSA-LAM® 2.0 3100 or 5½" VERSA-LAM 2.0 3100								Quadruple Ply 1½" VERSA-LAM® 2.0 3100 or 7" VERSA-LAM 2.0 3100					
	7½"	9½"	11½"	14"	7½"	9½"	11½"	14"	16"	18"	24"	9½"	11½"	14"	16"	18"	24"	11½"	14"	16"	18"	20"	24"			
-	954	1300	1782	2245	1908	2660	3564	4494	5334	532	526	3390	5346	726	1851	1648	1745	1738	1728	3081	1047	1043	1045	1045		
-	-	-	-	-	-	-	-	-	-	-	-	-	-	-	-	-	-	-	-	-	-	-	-	-		
-	2.2/5.5	3.1/7.6	4.1/10.7	5.1/12.9	2.2/5.5	3.1/7.6	4.1/10.7	5.1/12.9	6/15	7/15	8/15	3.1/7.6	4.1/10.7	5.1/12.9	6/15	7/15	8/15	3.1/7.6	4.1/10.7	5.1/12.9	6/15	7/15	8/15			
1	640	935	1225	1511	1279	1867	2449	3022	3611	3919	3913	2800	3674	4532	5417	5279	5676	5870	4999	3043	1222	7838	7834	7826		
1	482	-	-	-	965	-	-	-	-	-	-	-	-	-	-	-	-	-	-	-	-	-	-	-		
1	7/4	2.9/7.7	3.8/9.4	4.6/11.6	2/4.9	2.9/7.7	3.8/9.4	4.6/11.6	5.5/13.8	6/15	7/15	2.9/7.7	3.8/9.4	4.6/11.6	5.5/13.8	6/15	7/15	3.8/9.4	4.6/11.6	5.5/13.8	6/15	7/15	8/15			
1	376	583	932	1138	651	1386	1864	2275	2689	3322	3326	2679	2797	3413	4333	4698	4695	4686	3729	4550	5378	2263	2259	2251		
1	247	550	-	-	494	1111	-	-	-	-	-	1617	-	-	-	-	-	-	-	-	-	-	-	-		
1	1.5/3	2.7/6.6	3.6/8.9	4.4/10.8	1.5/3	2.7/6.6	3.6/8.9	4.4/10.8	5.2/12.9	6/15	6/15	2.7/6.6	3.6/8.9	4.4/10.8	5.2/12.9	6/15	6/15	3.6/8.9	4.4/10.8	5.2/12.9	6/15	6/15	6/15			
1	244	552	833	1012	437	1104	1665	2024	2384	2765	2839	1656	2498	3037	3576	448	4265	4259	3330	4049	4767	5531	5687	5679		
1	180	476	815	-	371	835	1631	-	-	-	-	1253	2446	-	-	-	-	3702	-	-	-	-	-	-		
1	1.5/3	2.3/5.8	3.5/8.8	4.3/10.7	1.5/3	2.3/5.8	3.5/8.8	4.3/10.7	5/12.6	5.8/14.6	6/15	2.3/5.8	3.5/8.8	4.3/10.7	5/12.6	5.8/14.6	6/15	6/15	3.5/8.8	4.3/10.7	5/12.6	5.8/14.6	6/15	6/15		
1	187	424	738	912	374	671	1465	1323	2141	2475	2007	1272	2198	2735	3211	3713	3107	3401	2401	3647	4781	4461	5209	5201		
1	143	322	628	-	280	645	1256	-	-	-	-	965	1814	-	-	-	-	-	2512	-	-	-	-	-		
1	1.5/3	2/4.9	3.4/8.4	4.2/10.6	1.5/3	2/4.9	3.4/8.4	4.2/10.6	5.4/12.3	6/15	6/15	2/4.9	3.4/8.4	4.2/10.6	5.4/12.3	6/15	6/15	3.4/8.4	4.2/10.6	5.4/12.3	6/15	6/15	6/15			
1	140	332	625	821	292	665	1247	1658	1942	2240	2399	947	1670	2487	2913	3360	3604	3598	2494	3316	3884	4480	4806	4797		
1	112	253	494	810	225	501	980	1619	-	-	-	751	1482	2429	-	-	-	-	1176	3238	-	-	-	-		
1	1.5/3	1.7/4.2	3.1/7.8	4.1/10.4	1.5/3	1.7/4.2	3.1/7.8	4.1/10.4	5.1/12.6	5.8/14.4	6/15	1.7/4.2	3.1/7.8	4.1/10.4	5.1/12.6	5.8/14.4	6/15	6/15	3.1/7.8	4.1/10.4	5.1/12.6	5.8/14.4	6/15	6/15		
1	16	265	521	734	233	530	1043	1467	1777	2046	2226	791	1564	2201	2666	3068	3345	3338	2085	2934	3554	4091	4459	4451		
1	90	205	390	611	180	405	791	1296	-	-	-	608	187	1444	-	-	-	-	1502	253	-	-	-	-		
1	1.5/3	1.5/3.6	2.0/7	4/6.9	1.5/3	1.5/3.6	2.0/7	4/6.9	4.6/12	5.5/13.3	6/15	1.5/3.6	2.0/7	4/6.9	4.8/12.3	5.5/13.3	6/15	6/15	2.0/7	4/6.9	4.6/12	5.5/13.3	6/15	6/15		
1	94	215	423	630	186	421	810	1276	1638	1882	2076	614	1268	1114	2456	2823	3120	3112	1091	2552	3275	3763	4159	4151		
1	73	165	322	527	141	321	643	1054	1573	-	-	494	965	1581	2360	-	-	-	1286	2108	3146	-	-	-		
1	1.5/3	1.5/3.1	2.5/6.1	3.7/9.2	1.5/3	1.5/3.1	2.5/6.1	3.7/9.2	4.7/11	8.5/19.3	6/15	1.5/3	2.5/6.1	3.7/9.2	4.7/11	8.5/19.3	6/15	6/15	2.5/6.1	3.7/9.2	4.7/11	8.5/19.3	6/15	6/15		
1	77	171	347	560	153	352	695	1120	1443	1742	1344	528	1042	1680	2165	2613	2917	2917	1389	2140	2887	3484	5397	3889		
1	60	130	265	434	121	271	530	811	1296	-	-	407	795	1333	1944	-	-	-	1000	1737	2563	-	-	-		
1	1.5/3	1.5/3	2.2/5.4	3.5/8.6	1.5/3	1.5/3	2.2/5.4	3.5/8.6	4.4/11	15.4/13.4	6/15	1.5/3	2.2/5.4	3.5/8.6	4.4/11	15.4/13.4	6/15	6/15	2.2/5.4	3.5/8.6	4.4/11	15.4/13.4	6/15	6/15		
1	63	143	281	476	127	292	577	951	1277	1597	1829	438	865	1427	1915	2395	2749	2743	1154	1902	2553	3193	3665	3657		
1	50	113	221	362	101	220	442	724	1081	1539	-	331	663	1086	1621	2308	-	-	684	1448	2111	3078	-	-		
1	1.5/3	1.5/3	1.9/4.2	3.1/7.8	1.5/3	1.5/3	1.9/4.2	3.1/7.8	4.2/10.5	5.2/13.1	6/15	1.5/3	1.9/4.2	3.1/7.8	4.2/10.5	5.2/13.1	6/15	6/15	1.9/4.2	3.1/7.8	4.2/10.5	5.2/13.1	6/15	6/15		
1	58	122	242	391	101	244	474	796	1137	1422	1726	367	726	1198	1705	2133	2572	2588	908	1598	2274	2845	3429	3451		
1	42	95	181	305	85	191	372	610	910	1296	-	280	558	915	1366	1944	-	-	744	1120	1821	253	-	-		
1	1.5/3	1.5/3	1.7/4.3	2.8/7	1.5/3	1.5/3	1.7/4.3	2.8/7	4/9	4.1/12.3	6/15	1.5/3	1.7/4.3	2.8/7	4/9	4.1/12.3	6/15	6/15	1.7/4.3	2.8/7	4/9	4.1/12.3	6/15	6/15		
1	103	205	331	489	89	200	400	677	1016	1275	1634	311	615	1016	1524	1912	2336	2450	870	1354	2032	2549	3115	3267		
1	81	158	251	421	72	162	310	511	774	1102	-	243	475	770	1161	1653	2168	-	-	633	1037	1548	2204	3024	-	
1	1.5/3	1.5/3.2	2.5/6.3	3.7/9.2	1.5/3	1.5/3.2	2.5/6.3	3.7/9.2	4.7/11.7	6/15	6/15	1.5/3	1.5/3.2	2.5/6.3	3.7/9.2	4.7/11.7	6/15	6/15	1.5/3.2	2.5/6.3	3.7/9.2	4.7/11.7	6/15	6/15		
1	68	175	281	471	75	170	350	571	861	1149	1551	263	525	861	1303	1723	2105	2326	691	1157	1737	2297	2807	3101		
1	69	136	222	362	121	271	445	614	945	-	-	208	407	667	991	1418	1944	-	543	881	1327	1890	2593	-		
1	1.5/3	1.5/3.4	2.3/5.6	3.4/8.4	1.5/3	1.5/3.4	2.3/5.6	3.4/8.4	4.4/11.1	6/15	6/15	1.5/3	1.5/3.4	2.3/5.6	3.4/8.4	4.4/11.1	6/15	6/15	1.5/3.4	2.3/5.6	3.4/8.4	4.4/11.1	6/15	6/15		
1	65	130	216	354	54	130	240	431	646	928	1407	114	390	647	973	1393	1735	2111	520	862	1297	1857	2313	2815		
1	52	102	167	271	41	104	204	334	491	710	-	151	300	501	748	1065	1461	-	400	611	997	1420	1948	-		
1	1.5/3	1.5/3	1.9/4.7	2.8/7	1.5/3	1.5/3	1.9/4.7	2.8/7	4/9	4.1/12.3	6/15	1.5/3	1.5/3	1.9/4.7	2.8/7	4/9	4.1/12.3	6/15	1.5/3	1.9/4.7	2.8/7	4/9	4.1/12.3	6/15		
1	99	164	-	-	98	197	311	491	711	1288	-	140	290	493	744	1066	1453	1832	395	650	992	1422	1937	2576		
1	79	171	-	-	80	151	251	384	541	-	-	121	231	381	570	820	1125	-	314	515	766	1094	1500	-		
1	1.5/3	1.6/3.9	2.3/5.9	3.3/8.3	1.5/3	1.5/3	1.6/3.9	2.3/5.9	3.3/8.3	6/15	6/15	1.5/3	1.5/3	1.6/3.9	2.3/5.9	3.3/8.3	4.5/11.3	6/15	1.5/3	1.6/3.9	2.3/5.9	3.3/8.3	4.5/11.3	6/15		
1	76	176	-	-	75	153	250	387	555	1164	12	221	383	500	833	1150	1747	305	51	773	1110	1533	2329			
1	62	101	-	-	62	124	202	302	430	1020	95	185	304	453	645	885	1529	241	405	604	860	1190	2039			
1	1.5/3	1.5/2.3	1.5/3.3	2/5	2.8/7.1	5.1/14.7	1.5/3	1.5/3	1.5/3.3	2/5	2.8/7.1	5.1/14.7	1.5/3	1.5/3	1.5/3.3	2/5	2.8/7.1	5.1/14.7	1.5/3	1.5/3.3	2/5	2.8/7.1	5.1/14.7	6/15	6/15	
1	60	101	-	-	58	120	202	300	441	1001	87	180	303	451	661	914	1501	240	404	612	882	1219	2001			
1	49	91	-	-	51	99	162	242	344	810	76	148	243	363	517	701	1224	198	324	484	686	945	1633			
1	1.5/3	1.5/3	-	-	1.5/3	1.5/3	1.7/4.3	2.4/6.1	5.5/13.7	1.5/3	1.5/3	1.5/3	1.7/4.3	2.4/6.1	5.5/13.7	1.5/3	1.5/3	1.7/4.3	2.4/6.1	5.5/13.7	1.5/3	1.5/3	1.7/4.3	2.4/6.1	5.5/13.7	
1	81	-	-	-	95	161	241	355																		

Closest Allowable Nail Spacing

VERSA-LAM® & VERSA-RIM® Products

Nail Size	VERSA-LAM® & VERSA-RIM® Products						Nailing Perpendicular to Glue Lines (Wide Face)	
	VERSA-LAM® 1.4 1:00 Rimboard 1 7/16"		VERSA-LAM® 1-4"		VERSA-LAM® 3 1/2" & Wider		All Products	
	O.C. [inches]	End [inches]	O.C. [inches]	End [inches]	O.C. [inches]	End [inches]	O.C. [inches]	End [inches]
8d Box	3	1 1/2	2	1	2	1/2	2	1/2
8d Common	3	2	3	2	2	1	2	1
10d & 12d Box	3	2	3	2	2	1	2	1
16d Box	3	2	3	2	2	1	2	1
10d & 12d Common	4	3	4	3	2	2	2	2
16d Sinker	4	3	4	3	2	2	2	2
16d Common	6	4	6	3	2	2	2	2

Nailing Parallel to Glue Lines (Narrow Face)

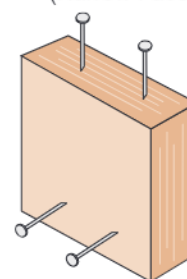

Nailing Perpendicular to Glue Lines (Wide Face)

Nailing Notes
 1) For 1 7/16" thickness and greater, 2 rows of nails (such as for a metal cap) are allowed (use 1/2" minimum offset between rows and stagger nails).

- Offset and stagger nail rows from floor sheathing and wall sole plate
- Simpson Strong-Tie A35 and LFT4 connectors may be attached to the side VERSA-LAM®, VERSA-RIM®. Use nails as specified by Simpson Strong-Tie.

VERSA-LAM® Design Values

Grade	Width [in]	Depth [in]	Weight [lb/ft]	Allowable Shear [lb]	Allowable Moment [ft-lb]	Moment of Inertia [in ⁴]	Grade	Width [in]	Depth [in]	Weight [lb/ft]	Allowable Shear [lb]	Allowable Moment [ft-lb]	Moment of Inertia [in ⁴]	
VERSA-STUD® 1.7 2:65C	1 1/2	3 1/2	1.5	968	776	5.4	VERSA-LAM® 2.0 3:100	5 1/4	5 1/4	8.0	5237	6330	3.3	
		5 1/2	2.4	1558	1821	20.8			5 1/2	8.4	4866	7457	72.8	
		7 1/4	3.2	2066	3039	47.6			7 1/4	11.0	7232	12366	166.7	
VERSA-LAM® 2.0 3:100	1 3/4	3 1/2	1.8	1164	1058	6.3			9 1/4	14.1	9227	19908	346.3	
		5 1/2	2.8	1829	2486	24.3			9 1/2	14.5	9476	20937	375.1	
		7 1/4	3.7	2411	4189	55.6			11 1/4	17.1	11222	28814	622.9	
		9 1/4	4.7	3076	6636	115.4			11 1/2	18.1	11845	31913	732.6	
		9 1/2	4.8	3159	6979	125.0			14	21.3	13965	43552	1200.5	
		11 1/4	5.7	3741	9605	207.6			16	24.4	15360	56046	1792.0	
		11 1/2	6.0	3948	10638	244.2			18	27.4	17355	70011	2551.5	
		14	7.1	4655	14517	400.2			20	30.4	19950	85428	3500.0	
		16	8.1	5320	18682	597.3			24	36.0	23940	120549	6048.0	
		18	9.1	5985	23337	850.5			7	9 1/4	16.6	12303	26544	461.7
		24	12.2	7980	40183	2016.0				9 1/2	17.1	12635	27916	500.1
		VERSA-LAM® 2.0 3:100	3 1/2	5 1/2	5.6	3658				4971	48.5	11 1/4	20.2	14963
7 1/4	7.4			4821	8377	111.1	11 1/2	21.4		15794	42550	976.8		
9 1/4	9.4			6151	13272	230.8	14	25.2		18620	58069	1600.7		
9 1/2	9.6			6318	13958	250.1	16	28.8		21280	74728	2389.3		
11 1/4	11.4			7481	19210	415.3	18	32.4		23940	93348	3402.0		
11 1/2	12.1			7897	21275	488.4	20	36.0		26600	113904	4666.7		
14	14.2			9310	29035	800.3	24	43.2	31920	160732	8064.0			
16	16.2			10640	37364	1194.7								
18	18.3	11970	46674	1701.0										
20	20.3	13300	56952	2333.3										

Design Property	Grade	Modulus of Elasticity	Bending	Horizontal Shear	Tension Parallel to Grain	Compression Parallel to Grain	Compression Perpendicular to Grain	Equivalent Specific Gravity for Fastener Design (SG)
		E (x 10 ⁶ psi) ⁽¹⁾	F _b (psi) ^{(2);(3)}	F _v (psi) ^{(2);(4)}	F _t (psi) ⁽⁵⁾	F _c (psi) ⁽²⁾	F _{c⊥} (psi) ^{(1);(6)}	
VERSA-LAM® Beams	2.0 3:100	2.0	3100	285	2150	3000	750	0.5
VERSA-LAM® Studs	1.7 2:65C	1.7	2650	285	1650	3000	750	0.5
VERSA-LAM® Columns	1.8 2:750	1.8	2750	285	1825	3000	750	0.5

1. This value cannot be adjusted for load duration.
 2. This value is based upon a load duration of 100% and may be adjusted for other load durations.
 3. Fiber stress bending value shall be multiplied by the depth factor, (12/d)^{1/8} where d = member depth [in].
 4. Stress applied perpendicular to the glue lines.
 5. Tension value shall be multiplied by a length factor, (4/L)^{1/8} where L = member length [ft]. Use L = 4 for members less than four feet long.
 6. Stress applied parallel to the glue lines.
- * Design properties are limited to dry conditions of use where the maximum moisture content of the material will not exceed 16%.

VERSA-LAM® 1.8 2750 Columns

Column Length [ft]	Allowable Axial Load (lb)														
	3 1/2" x 3 1/2"			3 1/2" x 4 3/8"			3 1/2" x 5 1/4"			3 1/2" x 5 1/2"			3 1/2" x 7"		
	100%	115%	125%	100%	115%	125%	100%	115%	125%	100%	115%	125%	100%	115%	125%
4	15,265	16,750	17,650	19,100	20,950	22,070	22,920	25,150	26,500	24,020	26,350	27,770	30,570	33,545	35,345
5	12,830	13,770	14,320	16,050	17,220	17,910	19,260	20,670	21,505	20,185	21,660	22,530	25,690	27,580	28,680
6	10,580	11,190	11,540	13,240	13,990	14,440	15,890	16,800	17,335	16,645	17,605	18,165	21,190	22,410	23,120
7	8,745	9,160	9,400	10,940	11,460	11,760	13,130	13,760	14,120	13,755	14,410	14,795	17,510	18,350	18,835
8	7,295	7,590	7,765	9,120	9,490	9,710	10,950	11,400	11,660	11,475	11,945	12,215	14,610	15,210	15,555
9	6,155	6,375	6,500	7,700	7,970	8,130	9,245	9,575	9,765	9,685	10,030	10,230	12,330	12,770	13,025
10	5,250	5,415	5,510	6,570	6,770	6,890	7,885	8,135	8,280	8,260	8,525	8,675	10,520	10,850	11,040
11	4,525	4,655	4,730	5,660	5,820	5,910	6,795	6,990	7,100	7,120	7,325	7,440	9,065	9,325	9,475
12	3,935	4,040	4,095	4,920	5,050	5,120	5,910	6,065	6,150	6,195	6,355	6,445	7,885	8,090	8,210
13	3,455	3,535	3,580	4,320	4,420	4,480	5,185	5,310	5,380	5,435	5,565	5,635	6,920	7,080	7,175
14	3,050	3,120	3,155	3,820	3,900	3,950	4,585	4,685	4,740	4,805	4,905	4,965	6,115	6,250	6,325
Column Length [ft]	3 1/2" x 7 1/4"			5 1/4" x 5 1/4"			5 1/4" x 5 1/2"			5 1/4" x 7"			5 1/4" x 7 1/4"		
	100%	115%	125%	100%	115%	125%	100%	115%	125%	100%	115%	125%	100%	115%	125%
	4	31,670	34,750	36,625											
5	26,615	28,560	29,705												
6	21,950	23,215	23,950	34,355	37,695	39,715	36,010	39,495	41,610						
7	18,140	19,005	19,505	30,700	33,170	34,625	32,165	34,750	36,280						
8	15,135	15,755	16,110	27,095	28,910	29,975	28,390	30,295	31,405	36,160	38,590	40,000	37,450	39,960	41,420
9	12,770	13,225	13,490	23,815	25,180	25,980	24,950	26,385	27,220	31,770	33,600	34,670	32,910	34,800	35,910
10	10,895	11,240	11,440	20,950	22,005	22,620	21,950	23,060	23,700	27,950	29,360	30,190	28,960	30,420	31,260
11	9,390	9,660	9,810	18,500	19,340	19,820	19,385	20,260	20,770	24,690	25,810	26,450	25,570	26,720	27,400
12	8,170	8,380	8,500	16,420	17,085	17,475	17,200	17,910	18,305	21,910	22,800	23,320	22,690	23,620	24,150
13	7,165	7,335	7,430	14,640	15,185	15,500	15,340	15,910	16,240	19,540	20,270	20,680	20,230	20,990	21,430
14	6,335	6,470	6,550	13,120	13,570	13,830	13,750	14,220	14,490	17,510	18,110	18,460	18,140	18,760	19,110
15				11,820	12,195	12,405	12,385	12,775	13,000	15,770	16,270	16,560	16,330	16,850	17,150
16				10,690	11,005	11,185	11,200	11,530	11,720	14,270	14,690	14,930	14,780	15,210	15,460
17				9,715	9,980	10,135	10,180	10,460	10,620	12,960	13,320	13,520	13,420	13,790	14,010
18				8,860	9,090	9,220	9,285	9,525	9,660	11,820	12,130	12,300	12,250	12,560	12,740
19				8,110	8,310	8,420	8,500	8,705	8,825	10,820	11,090	11,240	11,210	11,480	11,640
20				7,455	7,625	7,720	7,810	7,990	8,090	9,950	10,170	10,300	10,300	10,540	10,670
21				6,870	7,020	7,105	7,195	7,355	7,445	9,170	9,370	9,480	9,490	9,700	9,820
22															

Allowable Design Stresses	
Modulus of Elasticity:	$E = 1.8 \times 10^6$ psi
Bending: Parallel to Gluelines (Beam):	$F_b = 2750 \cdot (12/d)^{1/9}$ psi
Perp to Gluelines (Plank):	$F_b = 2500 \cdot (12/d)^{1/9}$ psi
Compression Parallel to Grain:	$F_{c } = 3000$ psi
Compression Perpendicular to Grain:	
Parallel to Gluelines (Beam):	$F_{c\perp} = 750$ psi
Perp to Gluelines (Plank):	$F_{c\perp} = 450$ psi
Tension Parallel to Grain:	$F_t = 1650$ psi

- Notes**
- Table assumes that the column is braced at column ends only. Effective column length is equal to actual column length.
 - Allowable loads are based upon one-piece (solid) column members used in dry service conditions. Contact project's design professional of record or Boise Cascade EWP Engineering for multi-piece column design.
 - Allowable loads are based on an eccentricity value equal to 0.167 multiplied by either the column thickness or width (worst case).
 - Allowable loads are based on axial loaded columns using the design provisions of the National Design Specification for Wood Construction (NDS), 2012 edition. For side or other combined bending and axial loads, see provisions of NDS, 2012 edition.
 - Load values are not shown for short lengths due to loads exceeding common connector capacities. Load values are not shown for longer lengths if the controlling slenderness ratio exceeds 50 (per NDS).
 - Lateral loads (wind loading) are not considered in this table.

VERSA-STUD® 1.7 2650

Allowable Design Values

Product	Bending F_b [psi]	Compression Parallel to Grain F_c [psi]	Modulus of Elasticity E [psi]	Horizontal Shear F_v [psi]
VERSA-STUD® 1.7 2650	2650	3000	1,700,000	285
Spruce Pine Fir (North) # 1 / 2 Grade	875	1150	1,400,000	135
Hem-Fir # 2 Grade	850	1300	1,300,000	150
Western Woods # 2 Grade	675	900	1,000,000	135

Notes:

- Design values are for loads applied to the narrow face of the studs.
- Dimension lumber values taken from 2012 NDS Supplement: Design Values for Wood Construction (per 2012 IBC/IRC).

- Repetitive member and size factors have not been applied. For further design information, please see VERSA-STUD 1.7 2650 Eastern Tall Wall Guide.



New BC FRAMER® represents a huge technological leap to help you improve the efficiency and profitability of your engineered wood products business. Boise Cascade will provide you what we believe is now the industry's best design software, offering far greater productivity than even our current version of BC FRAMER®. This new software package will help your design department work faster and accomplish more. You don't get paid to do drawings, but at least now you can do them in less time, and better.

- Shrink design time with BC FRAMER® model sharing.
- Save time & prevent mistakes with best-in-industry file integration.
- Experience the efficiencies of BC FRAMER® whole house modeling.
- Draw floor and wall plans simultaneously with BC FRAMER®.
- Check the plan every possible way with BC FRAMER® full 3-D viewer.
- Create a master plan and multiple options that can be quickly selected and exported to a plot-specific file in a few minutes – a fraction of the time it could have taken in the past.

Information can also be obtained at 1-800-405-5969 or email us at EWPSupport@BC.com.

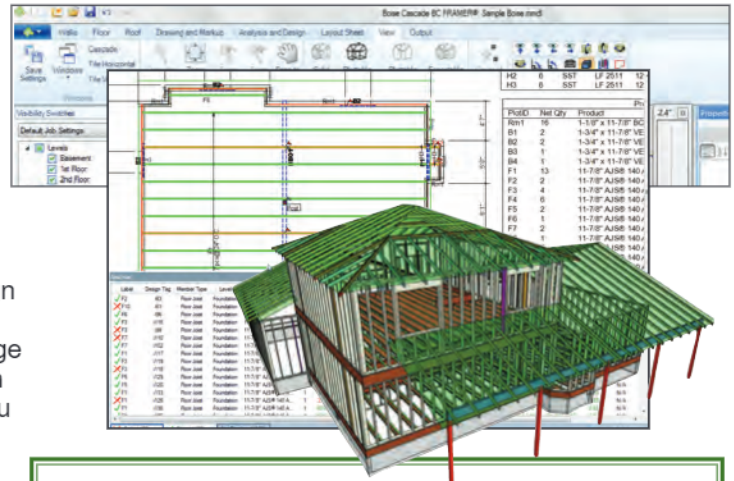

RECOMMENDED HARDWARE

- **CPU:** Quad Core 64 bit Intel i7 Processor (4th Generation or Newer)
- **L2 Cache:** 3MB/above
- **RAM:** 8GB (12.0 - 16GB highly recommended for designing large structures)
- **Video:** Full support for DirectX 9; Single monitor 512MB; Dual monitor 1GB (Resolution 1366x768 Minimum)
- **Free Storage:** 80GB (average 6,000-6,000 jobs)
- **Operating Systems:** Windows 7 (Professional Edition 64-bit), and Windows 8 (Professional Edition 64-bit), Windows 10 (Pro or Enterprise Edition 64-bit)*

*Apple Mac or Windows Emulator not supported

BC CALC® Sizing Software

This generation of BC CALC® was redesigned from the ground up with a focus on productivity and expanded functionality. BC CALC® performs engineering analysis to help our customers size beams, joists, columns, studs and tall walls for their building projects. It is simple to use yet flexible enough to analyze a variety of common applications. The user enters the member geometry, adds loads, holes and other relevant data and then selects a product for analysis. The program helps the user identify which of Boise Cascade's engineered wood products meet the demands of the application.

After the analysis has been run, the user can create an easy-to-read PDF design report that clearly shows important span and load information as well as the analysis results.

Boise Cascade has provided BC CALC® free of charge to the design community since 1994.



COMPUTER REQUIREMENTS

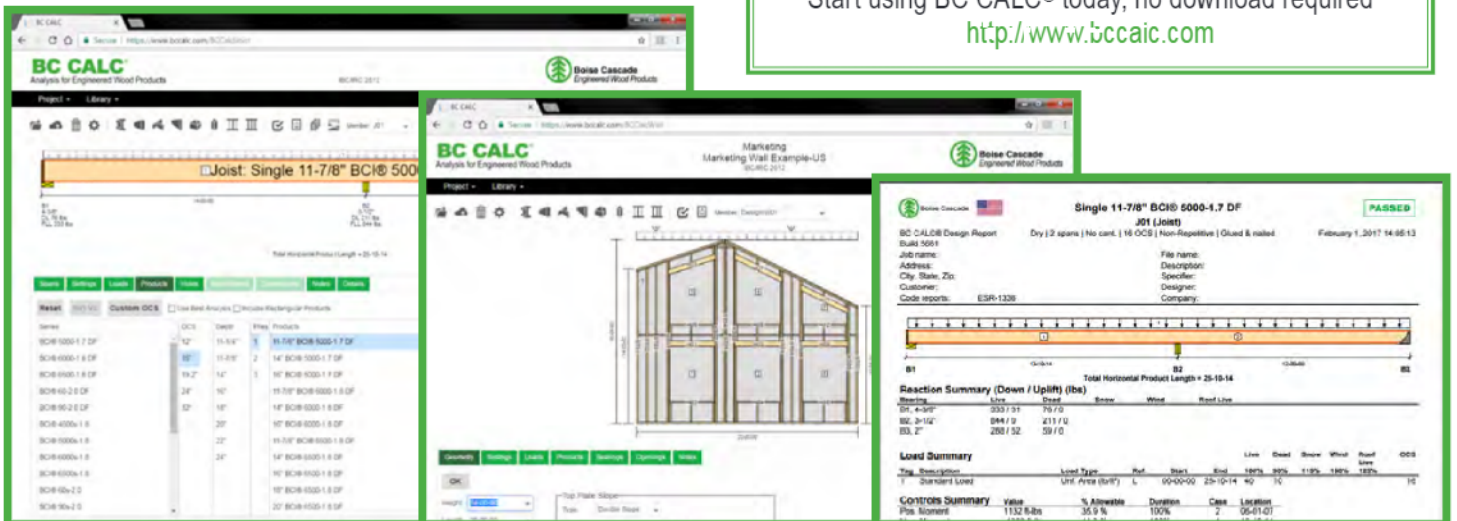

BC CALC® is now a web-based application available online and can be used on Windows or Apple operating systems via Internet Explorer, Edge, Chrome or Safari browsers. Additionally, iOS and Android tablets are now supported. For questions regarding BC CALC®, call 1-800-405-5969 or email EWPSupport@BC.com.

Start using BC CALC® today, no download required
<http://www.bccalc.com>

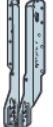
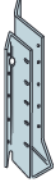

Framing Connectors - Simpson Strong-Tie

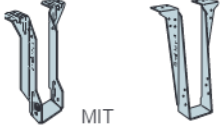
Single Joist - Top Flange						Single Joist - Face Mount						Face Mount Skewed 45° Joist Hanger					
																	
Joist Depth	AJS®	Hanger	Capacity [lbs]	Nailing		Joist Depth	AJS®	Hanger	Capacity [lbs]	Nailing		Joist Depth	AJS®	Hanger	Capacity [lbs]	Nailing	
				Header	Joist					Header	Joist					Header	Joist
9½"	20/190	ITS2.56/9.5	1006	6-10d	—	9½"	20/190	IUS2.56/9.5	950	8-10d	—	9½"	20/190	SUR/L2.56/9	1139	14-16d	2-10dx1½"
	25/30	ITS3.56/9.5	1006	6-10d	—		25/30	IUS3.56/9.5	1006	10-10d	—		25/30	SUR/L410	1076	14-16d	6-16d
11½"	20/190	ITS2.56/11.88	1020	6-10d	—	11½"	20/190	IUS2.56/11.88	1020	10-10d	—	11½"	20/190	SUR/L2.56/11	1174	16-16d	2-10dx1½"
	25/30	ITS3.56/11.88	1020	6-10d	—		25/30	IUS3.56/11.88	1020	12-10d	—		25/30	SUR/L410	1101	14-16d	6-16d
14"	20/190	ITS2.56/14	1032	6-10d	—	14"	20/190	IUS2.56/14	1032	12-10d	—	14"	20/190	SUR/L2.56/14	1204	18-16d	2-10dx1½"
	25/30	ITS3.56/14	1032	6-10d	—		25/30	IUS3.56/14	1032	12-10d	—		25/30	SUR/L414	1123	18-16d	8-16d
16"	20/190	ITS2.56/16	1048	6-10d	—	16"	20/190	IUS2.56/16	1048	14-10d	—	16"	20/190	SUR/L2.56/16	1235	18-16d	2-10dx1½"
	25/30	ITS3.56/16	1048	6-10d	—		25/30	IUS3.56/16	1048	14-10d	—		25/30	SUR/L414	1127	18-16d	8-16d

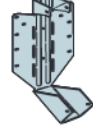

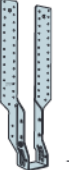
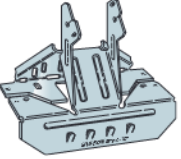
Double Joist - Top Flange						Double Joist - Face Mount						Field Slope and Skew Joist Hanger					
																	
Joist Depth	AJS®	Hanger	Capacity [lbs]	Nailing		Joist Depth	AJS®	Hanger	Capacity [lbs]	Nailing		Joist Depth	AJS®	Hanger	Capacity [lbs]	Nailing	
				Header	Joist					Header	Joist					Header	Joist
9½"	20/190	MIT39.5-2	2125	8-16d	2-10dx1½"	9½"	20/190	MIU5.12/10	2125	16-16d	2-10dx1½"	9½"	20/190	LSU410	1410	14-10d	12-10dx1½"
	25/30	B7.12/9.5	2720	14-16d	6-16d		25/30	HU410-2	2610	18-16d	8-16d		25/30	LSSU410	1410	14-10d	12-10dx1½"
11½"	20/190	MIT311.88-2	2170	8-16d	2-10dx1½"	11½"	20/190	MIU5.12/11	2170	20-16d	2-10dx1½"	11½"	20/190	LSSUH310	1505	14-10d	12-10dx1½"
	25/30	B7.12/11.88	2930	14-16d	6-16d		25/30	HU412-2	2930	22-16d	8-16d		25/30	LSSU410	1505	14-10d	12-10dx1½"
14"	20/190	MIT314-2	2210	8-16d	2-10dx1½"	14"	20/190	MIU5.12/14	2210	22-16d	2-10dx1½"	14"	20/190	LSSUH310	1600	14-10d	12-10dx1½"
	25/30	B7.12/14	3120	14-16d	6-16d		25/30	HU414-2	3120	26-16d	12-16d		25/30	LSSU410	1625	14-10d	12-10dx1½"
16"	20/190	MIT5.12/16	2255	8-16d	2-10dx1½"	16"	20/190	MIU5.12/16	2255	24-16d	2-10dx1½"	16"	20/190	—	—	—	—
	25/30	B7.12/16	3305	14-16d	6-16d		25/30	HU414-2	3305	26-16d	12-16d		25/30	—	—	—	—

Adjustable Height Joist Hanger						Variable Pitch Joist Connector					
											
Joist Depth	AJS®	Hanger	Capacity [lbs]	Nailing		Joist Depth	AJS®	Hanger	Capacity [lbs]	Fastener	
				Header	Joist					Top Plate	Rafter
9½"	20/190	THA12.06/22	1181	6-10d	2-10dx1½"	9½"	20/190	vPA3	1006	9-10d	2-10dx1½"
	25/30	THA15.22	1393	6-10d	2-10dx1½"		25/30	vPA4	1006	11-10d	2-10dx1½"
11½"	20/190	THA12.06/22	1443	6-10d	2-10dx1½"	11½"	20/190	vPA3	1020	9-10d	2-10dx1½"
	25/30	THA14.22	1710	6-10d	2-10dx1½"		25/30	vPA4	1020	11-10d	2-10dx1½"
14"	20/190	THA12.06/22	1500	6-10d	2-10dx1½"	14"	20/190	vPA3	1032	9-10d	2-10dx1½"
	25/30	THA13.22	1800	6-10d	2-10dx1½"		25/30	vPA4	1032	11-10d	2-10dx1½"
16"	20/190	THA13.22	1562	6-10d	2-10dx1½"	16"	20/190	vPA3	1048	9-10d	2-10dx1½"
	25/30	THA14.22	1710	6-10d	2-10dx1½"		25/30	vPA4	1048	11-10d	2-10dx1½"

SIMPSON Strong-Tie CONNECTORS

For more information, call Simpson Strong-Tie at 1-800-999-5399 or visit their website at www.strongtie.com

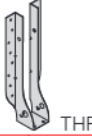
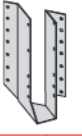
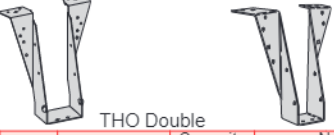
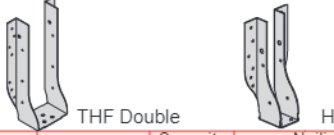
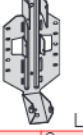
- General Notes**
- **Bold italic hangers require web stiffeners.**
 - Capacities will vary with different nailing criteria and/or support conditions; contact supplier or Simpson Strong-Tie for further information.
 - Capacity values shown are either hanger capacity values (see support requirements below) or AJS® Joist and reaction capacities — whichever is less.
 - All capacity values are downward loads at 100% load duration.
 - Use sloped seat hangers and b-value web stiffeners when AJS® Joist slope exceeds ¼" per foot.
 - Leave 1/8" clearance (¾" maximum) between the end of the supported joist and the head of the hanger.
 - At maximum design capacity shown, hangers may exceed standard 1/8" deflection by 1/32".
 - For proper installation of the VPA, the 2-10dx1½" joist nails through the end tabs must be installed at approximately a 45-degree angle.
- Support Requirements**
- Support must be assumed to be **BC** or **Cascade structural composite lumber or sawn timber (Douglas fir or southern pine species)**.
 - Minimum support width for single and double-joist top mount hangers is 1".
 - Minimum support width for face mount hangers with 10d and 16d nails is 1½" and 2", respectively.

Single Joist - Top Flange						Single Joist - Face Mount						Face Mount Skewed 45° Joist Hanger					
																	
Joist Depth	AJS®	Hanger	Capacity [lbs]	Nailing		Joist Depth	AJS®	Hanger	Capacity [lbs]	Nailing		Joist Depth	AJS®	Hanger	Capacity [lbs]	Nailing	
				Header	Joist					Header	Joist					Header	Joist
9½"	20 190	TFL2595	1006	6-10d	2-10dx1½"	9½"	20 190	THF25925	1062	12-10d	2-10dx1½"	9½"	20 190	SKH2520L/R	992	14-10d	10-10dx1½"
	25 30	THO35950	1048	10-10d	2-10dx1½"		25 30	THF35925	1062	12-10d	2-10dx1½"		25 30	SKH416L/R	1062	16-16d	10-16d
11½"	20 190	TFL25118	1020	6-10d	2-10dx1½"	11½"	20 190	THF25112	1085	14-10d	2-10dx1½"	11½"	20 190	SKH2520L/R	1003	14-10d	10-10dx1½"
	25 30	THO35118	1068	10-10d	2-10dx1½"		25 30	THF35112	1085	16-10d	2-10dx1½"		25 30	SKH410L/R	1055	16-16d	10-16d
14"	20 190	TFL2514	1032	6-10d	2-10dx1½"	14"	20 190	THF25140	1105	18-10d	2-10dx1½"	14"	20 190	SKH2524L/R	1014	16-10d	10-10dx1½"
	25 30	THO35140	1086	12-10d	2-10dx1½"		25 30	THF35140	1105	20-10d	2-10dx1½"		25 30	SKH414L/R	1105	22-16d	10-16d
16"	20 190	TFL2516	1048	6-10d	2-10dx1½"	16"	20 190	THF25160	1127	22-10d	2-10dx1½"	16"	20 190	SKH2524L/R	1029	16-10d	10-10dx1½"
	25 30	THO35160	1107	12-10d	2-10dx1½"		25 30	THF35157	1127	22-10d	2-10dx1½"		25 30	SKH414L/R	1127	22-16d	10-16d
Double Joist - Top Flange						Double Joist - Face Mount						Field Slope and Skew Joist Hanger					
																	
Joist Depth	AJS®	Hanger	Capacity [lbs]	Nailing		Joist Depth	AJS®	Hanger	Capacity [lbs]	Nailing		Joist Depth	AJS®	Hanger	Capacity [lbs]	Nailing	
				Header	Joist					Header	Joist					Header	Joist
9½"	20 190	THO25950-2	2237	10-16d	6-10d	9½"	20 190	THF25925-2	1390	12-10d	6-10d	9½"	20 190	LSSH25	1420	14-16d	12-10dx1½"
	25 30	BPH7195	2690	10-16d	6-10d		25 30	HD7100	1690	12-10d	6-10d		25 30	LSSH35	1420	14-16d	12-10dx1½"
11½"	20 190	THO25118-2	2300	10-16d	6-10d	11½"	20 190	THF25112-2	1355	16-10d	6-10d	11½"	20 190	LSSH25	1530	14-16d	12-10dx1½"
	25 30	BPH71118	3060	10-16d	6-10d		25 30	HD7120	2255	16-10d	6-10d		25 30	LSSH35	1530	14-16d	12-10dx1½"
14"	20 190	THO25140-2	2355	12-16d	6-10d	14"	20 190	THF25140-2	2210	20-10d	6-10d	14"	20 190	LSSH25	1630	14-16d	12-10dx1½"
	25 30	BPH7114	3260	10-16d	6-10d		25 30	HD7140	2520	20-10d	8-10d		25 30	LSSH35	1630	14-16d	12-10dx1½"
16"	20 190	THO25160-2	2412	12-16d	6-10d	16"	20 190	THF25160-2	2255	24-10d	8-10d	16"	20 190	LSSH25	1725	14-16d	12-10dx1½"
	25 30	BPH7116	3452	10-16d	6-10d		25 30	HD7160	3305	24-10d	8-10d		25 30	LSSH35	1725	14-16d	12-10dx1½"
Adjustable Height Joist Hanger						Variable Pitch Joist Connector											
																	
Joist Depth	AJS®	Hanger	Capacity [lbs]	Nailing		Joist Depth	AJS®	Hanger	Capacity [lbs]	Fastener							
				Header	Joist					Top Plate	Rafter						
9½"	20 190	MSH322	1270	16-10d	4-10dx1½"	9½"	20 190	TMP25	1175	6-10d	4-10dx1½"						
	25 30	MSH422IF	1770	22-10d	4-10d		25 30	TMP4	1175	6-10d	4-10dx1½"						
11½"	20 190	MSH322	1367	16-10d	4-10dx1½"	11½"	20 190	TMP25	1215	6-10d	4-10dx1½"						
	25 30	MSH422IF	1867	22-10d	4-10d		25 30	TMP4	1215	6-10d	4-10dx1½"						
14"	20 190	MSH322	1455	16-10d	4-10dx1½"	14"	20 190	TMP25	1250	6-10d	4-10dx1½"						
	25 30	MSH422IF	1955	22-10d	4-10d		25 30	TMP4	1250	6-10d	4-10dx1½"						
16"	20 190	MSH322	1413	16-10d	4-10dx1½"	16"	20 190	TMP25	1285	6-10d	4-10dx1½"						
	25 30	MSH422IF	1913	22-10d	4-10d		25 30	TMP4	1285	6-10d	4-10dx1½"						

USP STRUCTURAL CONNECTORS®
A Milltek Company

For more information, contact
USP Structural Connectors
at 1-800-320-5934 or
www.uspconnectors.com

- General Notes**
- **Bold italic hangers required web stiffeners.**
 - Capacities will vary with different nailing criteria and/or support conditions; contact supplier or USP Structural Connectors for further information.
 - Capacity values shown are either hanger capacity values (see support requirements below) or AJS® Joist end reaction capacities — whichever is less.
 - All capacity values are downward loads at 100% load duration.
 - Use sloped seat hangers and beveled web stiffeners when AJS® Joist slope exceeds 1" per foot.
 - Leave 1/8" clearance (1/4" maximum) between the end of the supported joist and the head of the hanger.
 - For AJS® Joist applications consult USP for capacity reduction.
- Support Requirements**
- Support material assumed to be Boise Cascade structural composite lumber or sawn lumber (Douglas fir or southern pine species).
 - Minimum support width for single- and double-joist top mount hangers is 3" (1½" for THO hangers).
 - Minimum support width for face mount hangers with 10d and 16d nails is 1½" and 2", respectively.



Boise Cascade Engineered Wood Products has a proven track record of providing quality wood products and a nationwide building materials distribution network for our customers, helping them to enhance their own businesses.

Boise Cascade Engineered Wood Products build better homes with stronger, stiffer floors using only wood purchased in compliance with a number of green building programs. Take a moment to view our sustainability certification site at <http://www.bc.com/sustainability/certification-audits/> or view our green brochure at www.bc.com/install.

Boise Cascade Engineered Wood Products throughout North America can now be ordered FSC® Chain-of-Custody (COC) certified, enabling homebuilders to achieve LEED® points residential and commercial green building programs including LEED for Homes and LEED for New Construction. Boise Cascade Engineered Wood Products are available as PEFC® Chain-of-Custody certified, SFI® Chain-of-Custody certified and SFI® Fiber-Sourcing certified, as well as NAHB Research Center Green Approved, enabling homebuilders to also obtain green building points through the Green Building Standards.

Lifetime Guaranteed Quality and Performance

Boise Cascade warrants its BCI® Joist, VERSA-LAM®, and ALLJOIST® products to comply with our specifications, to be free from defects in material and workmanship, and to meet or exceed our performance specifications for the normal and expected life of the structure when correctly stored, installed and used according to our Installation Guide.

If in doubt, ask!
For the number of the closest
Boise Cascade EWP
distributor/support center, call
800-232-0788

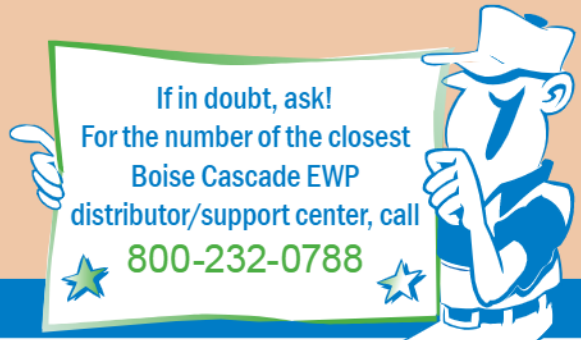

BOISE CASCADE, TREE-IN-A-CIRCLE, AJS, ALLJOIST, BCI, BC CALC, BC COLUMN, BC FRAMER, BOISE CASCADE, DIM BOARD, BOISE GLULAM, SIMPLE FRAMING SYSTEM, VERSA-LAM, VERSA-RIM, VERSA-STANDARD, and VERSA-STUD are trademarks of Boise Cascade Company or its affiliates.

For information about
Boise Cascade Engineered Wood Products,
including sales terms and conditions,
warranties and disclaimers,
visit our website at www.BCewp.com



Boise Cascade
Engineered Wood Products

Great products are only the beginning.®

Your Dealer is:

If no dealer is listed, call 1-800-232-0788