



Boise Cascade®
ENGINEERED WOOD PRODUCTS

Specifier Guide
AJS® Joists and Versa-Lam® LVL



AJS JOIST AND VERSA-LAM LVL SPECIFIER GUIDE

AJS Joists 140, 150, 20, 190, 25
and Versa-Lam LVL Beams

bc.com/ewp

Reorder #MTP-E7600

What You're Made of Matters

Boise Cascade AJS® joists are engineered to perform. With solid-sawn flanges manufactured with proprietary MSR (machine stress rated) lumber, they're made to deliver strength and consistency you can count on.

AJS® Joist Advantages

- ▶ Engineered to handle long spans for added design versatility.
- ▶ Lightweight and easy to handle for quick installation.
- ▶ Can be cut on-site without specialized skills or tools.
- ▶ Deep depths up to 24" to handle high loads and large holes in multi-family construction.
- ▶ Wide flanges make nailing quick and easy.
- ▶ BC FloorValue® software helps optimize floor performance before the first nail is driven.

Versa-Lam® LVL Advantages

- ▶ Best-in-class bending strength.
- ▶ No more limited layouts — long spans allow for greater design flexibility.
- ▶ Wide widths eliminate the need to build up multi-ply members.
- ▶ Installation made simple with depths designed to match BCI® and AJS® joists.
- ▶ High dimensional stability — no twisting, bowing, or warping.
- ▶ No camber for flat and quiet floors.

Boise Cascade Chain-Of-Custody Certifications

Boise Cascade Engineered Wood Products (EWP) has a proven track record of providing quality wood products and a nationwide building materials distribution network for our customers, helping them to enhance their own businesses.

Boise Cascade engineered wood products build better homes with stronger, stiffer floors using only wood purchased in compliance with a number of green building programs.

Take a moment to view our sustainability certification at bc.com/certification-wp/ or go to bc.com/sustainability for more information.

Boise Cascade engineered wood products throughout North America can be ordered FSC® Chain-of-Custody (COC) certified, enabling homebuilders to achieve LEED® points residential and commercial green building programs including LEED for Homes and LEED for New Construction.

Boise Cascade engineered wood products are available as PEFC® Chain-of-Custody certified, SFI® Chain-of-Custody certified and SFI® Fiber-Sourcing certified, as well as NAHB Research Center Green Approved, enabling homebuilders to also obtain green building points through the Green Building Standards.

TABLE OF CONTENTS

Boise Cascade Chain-Of-Custody Certifications	2
Product Storage and Handling	2
AJS Joists	
AJS Product Profiles and Architectural Specifications	3
Residential Floor Span Tables	4
One-Hour Fire Resistance Assembly	4
Floor Framing Details	5–6
Hole Location and Sizing	7
Cantilevers	8–10
Web Stiffener Requirements	10
Large Rectangular Holes	10
Floor Load Tables	11–13
Roof Framing Details	14–15
Roof Span Tables	16–21
Roof Load Tables	22–25
Design Properties	26
Rim Board Details and Properties	
27	
Versa-Lam LVL Beams	
Product Profiles and Architectural Specifications	28
Versa-Lam LVL Beam Details	28
Allowable Holes and Multiple Member Connections	29
Versa-Lam LVL Floor Load Table	30
Roof Load Tables	31–32
Allowable Nailing	33
Design Values and Allowable Stress Values	33
Versa-Lam LVL 1.8E 2650 Columns	34
Versa-Stud LVL 1.8E 2650	34
Boise Cascade Software	35
Framing Connectors	36–39

Code Evaluation Report: ICC-ES®/APA® ESR-1144 (IBC®, IRC®)

Protect product from rain and sun.

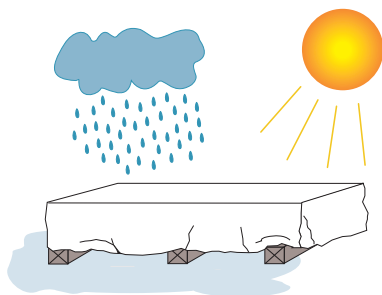

Keep product level and off the ground.

PRODUCT STORAGE AND HANDLING

- ▶ BCI® and AJS® joists and Versa-Lam® LVL
 - must be stored, installed and used in accordance with the Boise Cascade EWP Installation Guide, building codes and, to the extent not inconsistent with the Boise Cascade EWP Installation Guide, usual and customary building practices and standards.
 - must be wrapped, covered, and stored off of the ground on stickers at all times prior to installation.
 - are intended only for applications that ensure no exposure to weather or the elements and an environment that is free from moisture from any source, or any pest, organism or substance which degrades or damages wood or glue bonds.
- ▶ Unload products carefully and support to reduce excessive bowing. Use forklifts and cranes carefully to avoid damaging product
- ▶ Do not use a visibly damaged product. Contact your local Boise Cascade representative for assistance.
- ▶ Failure to correctly store, use, or install BCI® and AJS® joists or Versa-Lam® LVL in accordance with the Boise Cascade EWP Installation Guide will void the limited warranty.

AJS Product Profiles

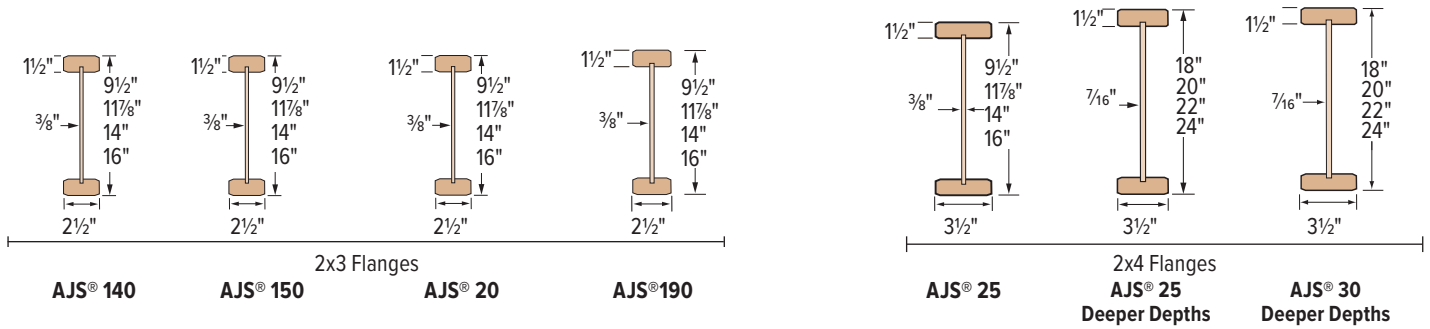

Architectural Specifications

AJS® Series Prefabricated Wood I-Joists

1.0 Evaluation Scope:

Compliance with the following codes:

- International Building Code® (IBC)
- International Residential Code® (IRC)

Properties Evaluated: Structural.

2.0 Uses:

The AJS® Joists are prefabricated wood I-joists used as floor joists, roof rafters and blocking panels, to support code-required loads. Prefabricated wood I-joists described in this report comply with Section 2303.1.2 of the IBC and Section R502.1.4 of the IRC, for allowable stress design.

3.0 Description:

3.1 General: The AJS® Series prefabricated wood I-joists have solid-sawn lumber or composite lumber flanges and oriented strand board (OSB) webs. The top and bottom flanges are parallel, creating constant-depth joists. The web-to-web joints of the I-joists are square butt joints and conform to the specifications in the approved quality control manuals. The web-to-flange connection is a proprietary grooved connection, also conforming to the approved quality control manuals. The I-joists are available in various lengths and depths. See ESR-1144 Table 1 for full description of the AJS® I-Joists.

3.2 Material Specifications:

3.2.1 Flanges: The flanges of the I-joists are sawn lumber or composite lumber conforming to the specifications in the approved quality control manuals. The lumber flanges are 1 1/2 inch x either 2 1/2 inch or 3 1/2 inch (38 mm x either 64 mm or 89 mm) spruce-pine-fir (SPF) and are used interchangeably with any of the sawn

lumber flanges of the same dimensions. The sawn lumber flange material, grade, width and depth are noted in ESR-1144, Table 1.

- 3.2.2 Web: Web material for the I-Joists is 3/8-inch-thick (10mm) or 7/16-inch-thick (11mm) OSB conforming to Exposure 1 requirements of DOC PS-2, with further requirements set forth in the approved quality control manuals and manufacturing standards.
- 3.2.3 Adhesive: Adhesives used in the fabrication of the I-joists are exterior-type, heat durable adhesives complying with ASTM D 2559 and ASTM D 5055, and are specified in the quality control manuals and the manufacturing standards.

4.0 Design and Installation:

Design of the prefabricated wood I-joists described in this report shall be in accordance with the applicable code. Additionally, the design and installation of the prefabricated wood I-joists shall comply with Sections 4.1 through 4.12 listed in ESR-1144 which include 4.1 Allowable Structural Capacity, 4.2 Fasteners, 4.3 Web Stiffeners, 4.4 Lateral Support, 4.5 Holes in I-Joist Web, 4.6 Duration of Load, 4.7 In-Service Moisture Conditions, 4.8 Repetitive- Member Use, 4.9 Member Spans, 4.10 Deflection, 4.11 Blocking Panels, & 4.12 Cantilevered Joists, and the manufacturer's installation instructions.

5.0 Conditions of Use:

The AJS® Series I-joists described in this report comply with, or are suitable alternatives to what is specified in, those codes listed under ESR-1144, Section 1.0 Evaluation Scope of these specifications, subject to the following conditions:

- 5.1 AJS® joists must be installed in accordance with this report and the manufacturer's installation instructions.
- 5.2 Drawings and design details verifying compliance with this report must be submitted to the code official when requested. The drawings and calculations must be prepared by a registered design professional where required by the statutes of the jurisdiction in which the project is to be constructed.
- 5.3 Flanges of the I-joist may not be cut or notched, unless an engineered design prepared by a registered design professional is submitted to the code official for approval.
- 5.4 The AJS® joists are manufactured by Boise Cascade Wood Products, L.L.C. at their plant in St. Jacques, New Brunswick, Canada under an approved quality control program with inspections by APA – The Engineered Wood Association (AA-649).

6.0 Evidence Submitted:

Data in accordance with the ICC-ES Acceptance Criteria for Prefabricated Wood I-joists (AC14), dated February 2013.

7.0 Identification:

AJS® I-joists are identified by a stamp indicating the joist model; company name (Boise Cascade Wood Products, L.L.C.); manufacturing location; evaluation report number (ESR-1144); and the name and logo of the inspection agency (APA).

AJS® Joists in Commercial Projects: The 18" and deeper depth AJS® joists are intended for commercial projects with heavier design loads and longer spans. All commercial projects utilizing AJS® joists shall have an engineer or architect of record.

Residential Floor Span Tables

About Floor Performance

Homeowner's expectations and opinions vary greatly due to the subjective nature of rating a new floor. Communication with the ultimate end user to determine their expectation is critical. **Vibration** is usually the cause of most complaints. Installing lateral bridging may help; however, squeaks may occur if not installed properly. Spacing the joists closer together does little to affect the perception of the floor's performance. The most common methods used to increase the performance and reduce vibration of wood floor systems is to **increase the joist depth, limit joist**

deflections, glue and screw a thicker, tongue-and-groove subfloor, install the joists vertically plumb with level-bearing supports, and install a direct-attached ceiling to the bottom flanges of the joists.

The floor span tables listed below offer three very different performance options, based on performance requirements of the homeowner.

Joist Depth	AJS® Joist Series	★★★ THREE STAR ★★★				★★★★ FOUR STAR ★★★★★				CAUTION	★ MINIMUM STIFFNESS	CAUTION	
		Live Load deflection limited to L/480: The common industry and design community standard for residential floor joists, 33% stiffer than L/360 code minimum. However, floor performance may still be an issue in certain applications, especially with 9½" and 11⅞" deep joists without a direct-attached ceiling.				Live Load deflection limited to L/960+: In addition to providing a floor that is 100% stiffer than the three star floor, field experience has been incorporated into the values to provide a floor with a premium performance level for the more discriminating homeowner.				Live Load deflection limited to L/360: Floors that meet the minimum building code L/360 criteria are structurally sound to carry the specified loads; however, there is a much higher risk of floor performance issues. This table should only be used for applications where floor performance is not a concern.			
		12" o.c.	16" o.c.	19.2" o.c.	24" o.c.	12" o.c.	16" o.c.	19.2" o.c.	24" o.c.	12" o.c.	16" o.c.	19.2" o.c.	24" o.c.
9½"	140	17'-9"	16'-3"	15'-4"	13'-11"	13'-11"	12'-8"	11'-11"	11'-1"	19'-8"	17'-0"	15'-6"	13'-11"
	150	18'-1"	16'-7"	15'-8"	14'-7"	14'-2"	12'-11"	12'-2"	11'-3"	20'-0"	18'-3"	16'-8"	14'-11"
	20	19'-1"	17'-5"	16'-5"	15'-4"	14'-10"	13'-6"	12'-9"	11'-10"	21'-1"	19'-3"	18'-2"	16'-4"
	190	19'-4"	17'-8"	16'-8"	15'-6"	15'-1"	13'-9"	12'-11"	12'-0"	21'-4"	19'-7"	18'-6"	17'-3"
	25	21'-0"	19'-1"	18'-0"	16'-9"	16'-4"	14'-10"	14'-0"	12'-11"	23'-2"	21'-1"	20'-0"	18'-2"
11⅞"	140	21'-2"	19'-4"	17'-8"	15'-10"	16'-7"	15'-1"	14'-3"	13'-3"	22'-5"	19'-5"	17'-8"	15'-10"
	150	21'-7"	19'-8"	18'-7"	17'-0"	16'-10"	15'-4"	14'-6"	13'-5"	23'-10"	20'-10"	19'-0"	17'-0"
	20	22'-8"	20'-9"	19'-7"	18'-3"	17'-9"	16'-2"	15'-2"	14'-1"	25'-1"	22'-10"	20'-10"	18'-8"
	190	23'-0"	21'-0"	19'-10"	18'-6"	18'-0"	16'-4"	15'-5"	14'-4"	25'-5"	23'-3"	21'-11"	19'-0"
	25	24'-11"	22'-9"	21'-5"	18'-3"	19'-6"	17'-8"	16'-8"	15'-5"	27'-7"	25'-2"	22'-10"	18'-3"
14"	140	24'-0"	21'-4"	19'-5"	17'-4"	18'-10"	17'-2"	16'-2"	15'-0"	24'-7"	21'-4"	19'-5"	17'-4"
	150	24'-6"	22'-4"	20'-10"	18'-7"	19'-2"	17'-6"	16'-5"	15'-3"	26'-5"	22'-10"	20'-10"	18'-7"
	20	25'-9"	23'-6"	22'-2"	19'-1"	20'-2"	18'-4"	17'-3"	16'-0"	28'-5"	25'-1"	22'-11"	19'-1"
	190	26'-1"	23'-10"	22'-6"	19'-1"	20'-5"	18'-7"	17'-6"	16'-3"	28'-10"	26'-4"	23'-11"	19'-1"
	25	28'-4"	25'-10"	22'-11"	18'-4"	22'-1"	20'-1"	18'-11"	17'-6"	31'-4"	27'-7"	22'-11"	18'-4"
16"	140	26'-6"	22'-11"	20'-11"	18'-9"	20'-10"	19'-0"	17'-11"	16'-8"	26'-6"	22'-11"	20'-11"	18'-9"
	150	27'-1"	24'-7"	22'-5"	19'-3"	21'-3"	19'-4"	18'-3"	16'-11"	28'-5"	24'-7"	22'-5"	19'-3"
	20	28'-6"	26'-0"	24'-2"	19'-3"	22'-4"	20'-4"	19'-1"	17'-9"	31'-3"	27'-0"	24'-2"	19'-3"
	190	28'-11"	26'-5"	24'-2"	19'-3"	22'-8"	20'-7"	19'-5"	18'-0"	31'-11"	28'-11"	24'-2"	19'-3"
	25	31'-4"	27'-10"	23'-2"	18'-6"	24'-6"	22'-3"	20'-11"	18'-6"	34'-8"	27'-10"	23'-2"	18'-6"

- ▶ Tables are based on
 - residential floor load of 40 psf live load and 10 psf dead load (12 psf dead load for AJS 25 joists).
 - 2³/₃₂" minimum plywood/OSB rated sheathing glued and nailed to joists for composite action.
 - the most restrictive of simple or multiple span applications. Analyze multiple span joists with BC Calc® sizing software if the length of any span is less than half the length of an adjacent span.
 - maximum allowable clear distance between supports.
 - minimum bearing lengths without web stiffeners for joist depths of 16" and less.

- ▶ All 18" and 20" AJS® joists require web stiffeners at all bearing locations
- ▶ Floor tile will increase dead load and may require specific deflection limits, contact Boise Cascade EWP Engineering for further information.
- ▶ This table was designed to apply to a broad range of applications. It may be possible to exceed the limitations of this table by analyzing a specific application with the BC Calc® sizing software.

Gold-shaded values may not satisfy the requirements of the North Carolina State Building Code. Refer to the THREE STAR table when spans exceed 20 feet.

One-Hour Fire Resistance Assembly (ICC-ES®/APA® ESR-1144)

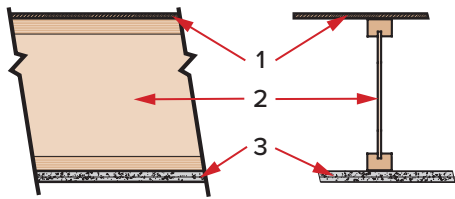

Fire Assembly Components

- (1) Min. 2³/₃₂" thick tongue and groove sheathing (exterior glue), installed with long edge perpendicular to joist length, staggered one joist spacing with adjacent sheets, and glued to joists with construction adhesive.
- (2) AJS® joists at 24" o.c. or less.
- (3) Two layers 5/8" Type X or two layers 1/2" Type C gypsum board, installed per Figures 2 or 3 of ICC-ES®/APA® ESR-1144.

Sound Assembly Components (when constructed with resilient channels)

- Add carpet and pad to fire assembly STC=54 IIC=68 or
- Add 3½" glass fiber insulation to fire assembly STC=55 IIC=46 or
- Add an additional layer of minimum 5/8" sheathing and 9½" glass fiber insulation to fire assembly STC=61 IIC=50

See the US version of the *Boise Cascade Fire Design and Installation Guide* for specific assembly information and other fire resistance assemblies and details.

Floor Framing

The illustration below is showing several suggested applications for the Boise Cascade EWP products. It is not intended to show an actual house under construction.

NO MIDSPAN BRIDGING IS REQUIRED FOR AJS® JOISTS

FOR INSTALLATION STABILITY:

Temporary strut lines (1x4 min., 8' o.c. max. Fasten at each joist with two 2½" (8d) nails minimum.

Dimension lumber is not suitable for use as a rim board in AJS® joist floor systems.

SAFETY WARNING

DO NOT allow workers on AJS® joists until all hangers, AJS® rim joists, rim boards, AJS® blocking panels, x-bracing and temporary 1x4 strut lines are installed as specified below. Serious accidents can result from insufficient attention to proper bracing during construction. Accidents can be avoided under normal conditions by following these guidelines:

- ▶ Build a braced end wall at the end of the bay, or permanently install the first eight feet of AJS® joists and the first course of sheathing. As an alternate, temporary sheathing may be nailed to the first four feet of AJS® joists at the end of the bay.
- ▶ All rim joists, rim boards, x-bracing, blocking panels and hangers must be completely installed and properly nailed as each AJS® joist is set.
- ▶ Install temporary 1x4 strut lines at 8' on-center or closer as additional AJS® joists are set. Nail the strut lines to the sheathed area or braced end wall, and to each AJS® joist with two 2½" (8d) nails.
- ▶ The ends of cantilevers must be temporarily secured by strut lines on both the top and bottom flanges.
- ▶ Straighten the AJS® joists to within ½" of true alignment before attaching strut lines and sheathing.
- ▶ Remove the temporary strut lines only as required to install the permanent sheathing.
- ▶ Failure to install temporary bracing may result in sideways buckling or roll-over under light construction loads.
- ▶ Do not stack construction materials (sheathing, drywall, etc.) in the middle of AJS® joist spans. Contact Boise Cascade EWP Engineering for proper storage and shoring information.

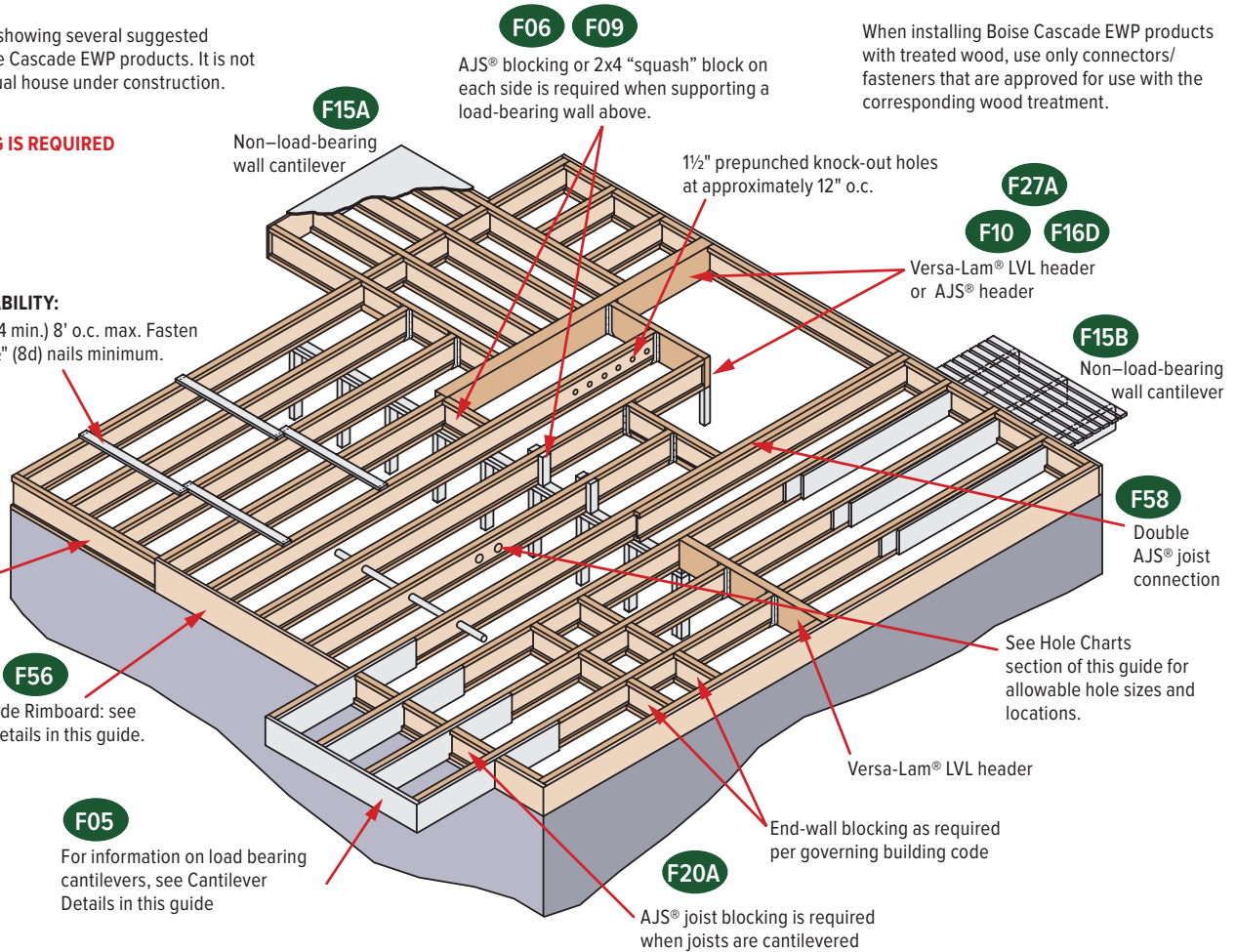

When installing Boise Cascade EWP products with treated wood, use only connectors/ fasteners that are approved for use with the corresponding wood treatment.

Nailing Requirements

- ▶ **AJS® rim joist, rim board or closure panel to AJS® joist:**
 - Rim or closure panel 1¼" thick or less: Two 8d nails, one each in the top and bottom flange.
 - AJS® 140/150/20/190 rim joist: Two 16d box nails, one each in the top and bottom flange.
 - AJS® 25 rim joist: Toe-nail top flange to rim joist with two 10d box nails, one each side of flange.
- ▶ **AJS® rim joist, rim board or AJS® blocking panel to support:**
 - Minimum 8d nails at 6" o.c. per IRC®.
 - Connect per design professional of record's specification for shear transfer.
- ▶ **AJS® joist to support:**
 - Two 8d nails, one on each side of the web, placed 1½" minimum from the end of the AJS® joist to limit splitting.
- ▶ **Sheathing to AJS® joist:**
 - Prescriptive nailing for residential floor sheathing requires 8d common nails at 6" o.c. at edges and 12" o.c. in the field (IRC® Table R602.3(1)).
 - See Closest Allowable Nail Spacing limits on page 24 for floor diaphragm nailing specified at closer spacing than IRC®.
 - For full lateral stability, maximum nail spacing for bracing is 18" for AJS® 140/150/20/190, and 24" for larger AJS® joist series.
 - 14 gauge staples may be substituted for 8d nails if the staples penetrate at least 1" into the joist.
 - Wood screws may be acceptable; contact local building official and/or Boise Cascade EWP Engineering for more information.

AJS® Joist Slope Cut Reinforcement

Detail below restores the original allowable shear/reaction value to cut end of AJS® joist. AJS® joists shall not be used as a collar or rafter tension tie.

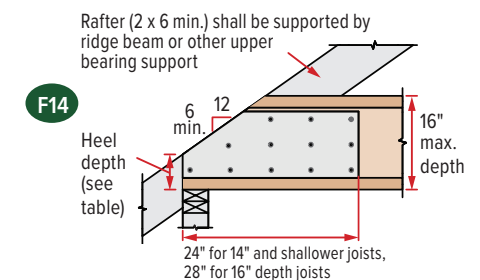

2x blocking required at bearing (not shown for clarity). 23/32" min. plywood/OSB-rated sheathing as reinforcement. Install reinforcement with face grain horizontal. Install on both sides of the joist, tight to bottom flange. Leave minimum ¼" gap between reinforcement and bottom of top flange. Apply construction adhesive to contact surfaces and fasten with 3 rows of min. 10d box nails at 6" o.c. Alternate nailing from each side and clinch.

End Wall Bearing	Minimum Heel Depth				
	Roof Pitch				
	6:12	7:12	8:12	9:12	10:12 12:12
2 x 4	4¾"	4⅝"	4¼"	4¼"	4¼"
2 x 6	3⅝"	3⅜"	2⅝"	2¾"	2⅞"

PROTECT AJS® JOISTS FROM THE WEATHER

AJS® joists are intended only for applications that provide permanent protection from the weather. Product bundles should be covered and stored off of the ground on stickers. Also see PRODUCT STORAGE AND HANDLING on page 2.

Floor Framing Details

End Bearing Details

F07

Dimension lumber is not suitable for use as rim board with AJS joists.

Rim board: Nail to AJS joists with 2½" (8d) nail into each flange.

F07A

Dimension lumber is not suitable for use as rim board with AJS joists.

Blocking may be required perpendicular to wall, consult design professional of record and/or local building official.

Boise Cascade rimboard or AJS joist

F01

AJS joist blocking

F02

AJS rim joist

AJS rim joist requires 2x6 wall for minimum bearing

F27A

Top flange or face mount joist hanger

Versa-Lam LVL

F52

One 8d nail each side at bearing

½" minimum bearing length

To limit splitting flange, start nails at least ½" from end. Nails may need to be driven at an angle to limit splitting of bearing plate.

F08

Use solid blocking under all posts above for support to the bearing plate.

F03

Boise Cascade rimboard

AJS floor joist must be designed to carry wall above when not stacked over wall below.

Blocking required underneath braced wall panels and shear walls. Consult design profession of record.

Intermediate Bearing Details

F06

For load bearing wall above (stacked over wall below)

AJS joist blocking

Per IRC, blocking may be required at intermediate bearing for floor diaphragm in high seismic areas; consult local building official.

F09

Load bearing wall above (stacked over wall below)

2x block

¼" minimum bearing length

Size	Joist Spacing			
	12"	16"	19.2"	24"
2x4	4,463	3,347	2,789	2,231
2x6	7,013	5,259	4,383	3,506

► Squash blocks are to be in full contact with upper floor and lower wall plate.

► Capacities shown are for double squash blocks at each joist, SPF or better.

F10

Backer block (minimum 12" wide). Nail with ten 10d nails.

Joist hanger

Filler block. Nail with ten 10d nails.

A backer block is required where top flange hanger load exceeds 250 lbs. All face mount hangers require backer blocks on both sides of the supporting joist's web.

For top flange hangers install tight to top flange. For face mount hangers, install tight to the bottom flange.

F05

Sheathing or rim board closure

AJS joist blocking required for cantilever

For load bearing cantilever, see page 9. Uplift on backspan shall be considered in all cantilever designs.

F58

Double AJS Joist Connection

Filler block (if required).

Web filler nailing

- Filler block not required when all loads are top loaded and evenly applied to each ply (except AJS 90 joist).
- Side loads or uneven top loads require filler block.
- Fasten floor sheathing to each ply per diaphragm nailing schedule.

See BC Tech Note 1J-13 for more information on nailing and filler block requirements.

Lateral Support

- AJS joists shall be laterally supported at the ends with hangers, rim board, AJS rim joists or blocking panels. AJS blocking panels or rim board are required at cantilever supports.
- Per IRC, blocking may be required at intermediate bearings for floor diaphragm. In high seismic areas, consult local building official.

Minimum Bearing Length For AJS Joists

- 1½" is required at end supports. 3½" is required at cantilever and intermediate supports.
- Longer bearing lengths allow higher reaction values. Refer to the building code evaluation report or the BC Calc software.

Backer and Filler Block Dimensions

Series	Backer Block Thickness	Filler Block Thickness
140	1⅝" or two ½" wood panels	2 x ⅞" or ½" wood panel
1500		
20		
190	2 x lumber	Double 2 x lumber
25		

- Cut backer and filler blocks to a maximum depth equal to the web depth minus ¼" to avoid a forced fit.
- For deeper AJS Joists, stack 2x lumber or use multiple pieces of ¾" wood panels.

AJS Rim Joists and Blocking

Depth	Vertical Load Transfer Capacity (PLF)
9½"	2,300
11⅞"	2,150
14"	2,000
16"	1,900
18"	N/A
20"	N/A

- Web stiffeners required at each end of blocking panel. Distance between stiffeners must be less than 24".
- N/A: Not applicable

Hole Location and Sizing

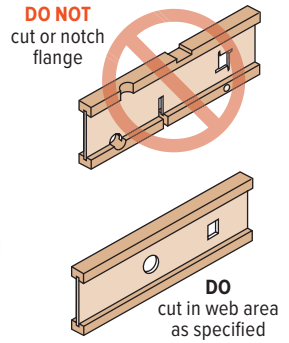
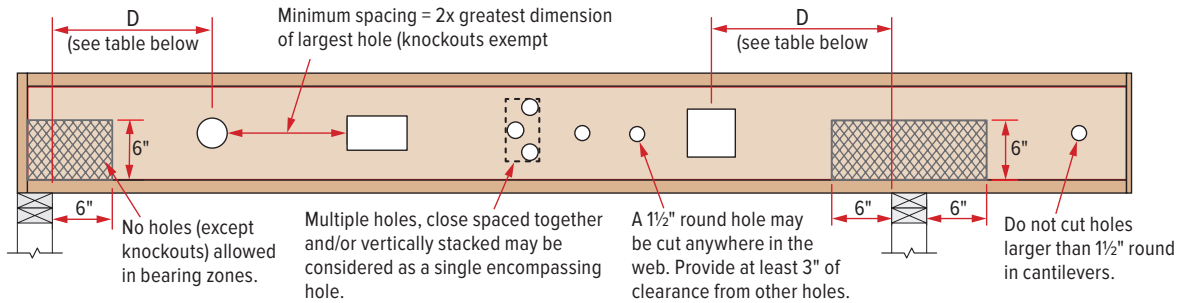

AJS® joists are manufactured with 1½" round perforated knockouts in the web at approximately 12" o.c. Minimum distance from support, listed in table below, is required for all holes greater than 1½".

Minimum Distance (D) From Any Support To The Centerline Of The Hole																
Round Hole Diameter		2"	3"	4"	5"	6"	6½"	7"	8"	8¾"	9"	10"	11"	12"	13"	
Rectangular Hole Side		-	-	2"	3"	5"	7"	-	-	-	-	-	-	-	-	
Any 9½" Joist	Span	8'	2'-0"	2'-5"	2'-11"	3'-5"	3'-10"	4'-0"								
		12'	3'-0"	3'-8"	4'-5"	5'-1"	5'-10"	6'-0"								
		16'	4'-0"	4'-11"	5'-11"	6'-10"	7'-9"	8'-0"								
Round Hole Diameter		2"	3"	4"	5"	6"	6½"	7"	8"	8¾"	9"	10"	11"	12"	13"	
Rectangular Hole Side		-	-	-	2"	3"	4"	5"	7"	8"	-	-	-	-	-	
Any 11⅞" Joist	Span	8'	1'-0"	1'-5"	1'-10"	2'-3"	2'-8"	2'-11"	3'-1"	3'-6"	3'-11"					
		12'	1'-5"	2'-1"	2'-9"	3'-5"	4'-0"	4'-4"	4'-8"	5'-4"	5'-11"					
		16'	1'-11"	2'-10"	3'-8"	4'-6"	5'-5"	5'-10"	6'-3"	7'-1"	7'-10"					
		20'	2'-5"	3'-6"	4'-7"	5'-8"	6'-9"	7'-3"	7'-10"	8'-11"	9'-10"					
Round Hole Diameter		2"	3"	4"	5"	6"	6½"	7"	8"	8¾"	9"	10"	11"	12"	13"	
Rectangular Hole Side		-	-	-	-	2"	3"	3"	5"	6"	6"	8"	9"	-	-	
Any 14" Joist	Span	8'	1'-0"	1'-1"	1'-2"	1'-4"	1'-8"	1'-11"	2'-1"	2'-6"	2'-10"	2'-11"	3'-4"	3'-9"		
		12'	1'-0"	1'-1"	1'-4"	2'-0"	2'-7"	2'-11"	3'-2"	3'-10"	4'-4"	4'-5"	5'-0"	5'-7"		
		16'	1'-0"	1'-1"	1'-10"	2'-8"	3'-5"	3'-10"	4'-3"	5'-1"	5'-9"	5'-11"	6'-8"	7'-6"		
		20'	1'-0"	1'-1"	2'-4"	3'-4"	4'-4"	4'-10"	5'-4"	6'-4"	7'-3"	7'-4"	8'-5"	9'-5"		
		24'	1'-0"	1'-1"	2'-9"	4'-0"	5'-2"	5'-10"	6'-5"	7'-8"	8'-8"	8'-10"	10'-1"	11'-3"		
Round Hole Diameter		2"	3"	4"	5"	6"	6½"	7"	8"	8¾"	9"	10"	11"	12"	13"	
Rectangular Hole Side		-	-	-	-	-	-	2"	3"	5"	5"	6"	7"	8"	10"	
Any 16" Joist	Span	8'	1'-0"	1'-1"	1'-2"	1'-2"	1'-3"	1'-3"	1'-3"	1'-8"	2'-0"	2'-1"	2'-5"	2'-10"	3'-2"	3'-7"
		12'	1'-0"	1'-1"	1'-2"	1'-2"	1'-4"	1'-8"	1'-11"	2'-6"	3'-0"	3'-1"	3'-8"	4'-3"	4'-10"	5'-5"
		16'	1'-0"	1'-1"	1'-2"	1'-2"	1'-10"	2'-2"	2'-7"	3'-4"	4'-0"	4'-2"	4'-11"	5'-8"	6'-5"	7'-2"
		20'	1'-0"	1'-1"	1'-2"	1'-4"	2'-3"	2'-9"	3'-3"	4'-3"	5'-1"	5'-2"	6'-2"	7'-1"	8'-1"	9'-0"
		24'	1'-0"	1'-1"	1'-2"	1'-7"	2'-9"	3'-4"	3'-11"	5'-1"	6'-1"	6'-3"	7'-4"	8'-6"	9'-8"	10'-10"

HOW TO USE THIS TABLE

- Select a table row based on joist depth and the actual joist span rounded up to the nearest span shown in the table.
- Scan across the row to the column for the appropriate round hole diameter or rectangular hole side. Use the longest side of a rectangular hole.
- The table value shown is the closest that the centerline of the hole may be to the edge or face of the nearest support.

NOTES

- ▶ **DO NOT** cut joist flanges.
- ▶ Holes apply to either single or multiple joists in repetitive member conditions.
- ▶ For multiple holes, the amount of horizontal uncut web between holes must equal at least twice the diameter (or longest side) of the largest hole.
- ▶ Table assumes one hole per horizontal location. Holes located above or below another should be considered as a single hole that encompasses all the holes.
- ▶ 1½" round knockouts in the web may be removed by using a short piece of metal pipe and hammer.
- ▶ Single holes may be positioned anywhere vertically in the web, provided they do not extend into either flange.
- ▶ This table was designed to apply *only* to the design conditions covered by tables elsewhere in this publication (maximum uniform PLF load).
- ▶ Use the BC Calc® software to check other hole sizes or holes in other design conditions. It may be possible to exceed the limitations of this table by analyzing a specific application with the BC Calc® software.

AJS Joists—Reinforced Load-Bearing Cantilevers

AJS® Joist Series	Joist Depth	Roof Truss Span	Roof Total Load (PSF)																																																																																										
			35			45			55																																																																																				
			16"	19.2"	24"	16"	19.2"	24"	16"	19.2"	24"																																																																																		
140	9½"	24'	0	0	1	0	0	X	0	X	X	26'	0	0	1	0	1	X	1	X	X	28'	0	0	X	0	1	X	1	X	X	30'	0	0	X	0	X	X	X	X	X	32'	0	0	X	1	X	X	X	X	X	34'	0	1	X	1	X	X	X	X	X	36'	0	1	X	1	X	X	X	X	X	38'	0	X	X	X	X	X	X	X	X	40'	0	X	X	X	X	X	X	X	X		
		11½"	24'	0	0	0	0	0	0	0	0	X	26'	0	0	0	0	0	1	0	0	X	28'	0	0	0	0	0	1	0	1	X	30'	0	0	0	0	0	X	0	1	X	32'	0	0	0	0	0	X	0	1	X	34'	0	0	1	0	0	X	0	X	X	36'	0	0	1	0	1	X	1	X	X	38'	0	0	1	0	1	X	1	X	X	40'	0	0	X	0	1	X	1	X	X	
			14"	24'	0	0	0	0	0	0	0	0	WS	26'	0	0	0	0	0	WS	0	0	WS	28'	0	0	0	0	0	WS	0	0	1	30'	0	0	0	0	0	WS	0	0	1	32'	0	0	0	0	0	WS	0	WS	X	34'	0	0	0	0	0	1	0	WS	X	36'	0	0	WS	0	0	1	0	1	X	38'	0	0	WS	0	0	1	0	1	X	40'	0	0	WS	0	WS	X	0	1	X
				16"	24'	0	0	0	0	0	0	0	0	WS	26'	0	0	0	0	0	WS	0	0	WS	28'	0	0	0	0	0	WS	0	0	WS	30'	0	0	0	0	0	WS	0	WS	WS	32'	0	0	0	0	0	WS	0	WS	1	34'	0	0	WS	0	0	WS	0	WS	1	36'	0	0	WS	0	0	WS	0	WS	1	38'	0	0	WS	0	WS	WS	0	WS	X	40'	0	0	WS	0	WS	1	0	WS

AJS® Joist Series	Joist Depth	Roof Truss Span	Roof Total Load (PSF)																																																																																										
			35			45			55																																																																																				
			16"	19.2"	24"	16"	19.2"	24"	16"	19.2"	24"																																																																																		
150	9½"	24'	0	0	1	0	0	2	0	1	X	26'	0	0	1	0	1	X	1	2	X	28'	0	0	1	0	1	X	1	X	X	30'	0	0	2	0	1	X	1	X	X	32'	0	0	2	1	2	X	2	X	X	34'	0	1	X	1	2	X	2	X	X	36'	0	1	X	1	X	X	X	X	X	38'	0	1	X	1	X	X	X	X	X	40'	0	1	X	2	X	X	X	X	X		
		11½"	24'	0	0	0	0	0	0	0	0	1	26'	0	0	0	0	0	1	0	0	1	28'	0	0	0	0	0	1	0	1	X	30'	0	0	0	0	0	1	0	1	X	32'	0	0	0	0	0	1	0	1	X	34'	0	0	1	0	0	2	0	1	X	36'	0	0	1	0	1	X	1	2	X	38'	0	0	1	0	1	X	1	2	X	40'	0	0	1	0	1	X	1	X	X	
			14"	24'	0	0	0	0	0	0	0	0	WS	26'	0	0	0	0	0	WS	0	0	WS	28'	0	0	0	0	0	WS	0	0	1	30'	0	0	0	0	0	WS	0	WS	1	32'	0	0	0	0	0	WS	0	WS	1	34'	0	0	WS	0	0	1	0	WS	X	36'	0	0	WS	0	0	1	0	1	X	38'	0	0	WS	0	WS	1	0	1	X	40'	0	0	WS	0	WS	1	WS	1	X
				16"	24'	0	0	0	0	0	0	0	0	WS	26'	0	0	0	0	0	WS	0	0	WS	28'	0	0	0	0	0	WS	0	0	WS	30'	0	0	0	0	0	WS	0	WS	WS	32'	0	0	0	0	0	WS	0	WS	1	34'	0	0	WS	0	0	WS	0	WS	1	36'	0	0	WS	0	0	WS	0	WS	1	38'	0	0	WS	0	WS	WS	0	WS	1	40'	0	0	WS	0	WS	1	WS	WS

AJS® Joist Series	Joist Depth	Roof Truss Span	Roof Total Load (PSF)																																																																																										
			35			45			55																																																																																				
			16"	19.2"	24"	16"	19.2"	24"	16"	19.2"	24"																																																																																		
20	9½"	24'	0	0	1	0	0	2	0	2	X	26'	0	0	1	0	1	X	1	2	X	28'	0	0	1	0	1	X	1	2	X	30'	0	0	2	0	2	X	1	X	X	32'	0	0	2	1	2	X	2	X	X	34'	0	1	2	1	2	X	2	X	X	36'	0	1	X	1	X	X	2	X	X	38'	0	1	X	1	X	X	X	X	X	40'	0	2	X	2	X	X	X	X	X		
		11½"	24'	0	0	0	0	0	WS	0	0	1	26'	0	0	0	0	0	1	0	0	2	28'	0	0	0	0	0	1	0	1	X	30'	0	0	0	0	0	1	0	1	X	32'	0	0	WS	0	0	2	0	1	X	34'	0	0	1	0	0	X	0	1	X	36'	0	0	1	0	1	X	1	2	X	38'	0	0	1	0	1	X	1	2	X	40'	0	0	1	0	1	X	1	X	X	
			14"	24'	0	0	0	0	0	0	0	0	WS	26'	0	0	0	0	0	WS	0	0	WS	28'	0	0	0	0	0	WS	0	0	1	30'	0	0	0	0	0	WS	0	WS	1	32'	0	0	0	0	0	WS	0	WS	1	34'	0	0	WS	0	0	1	0	WS	X	36'	0	0	WS	0	WS	1	0	1	X	38'	0	0	WS	0	WS	1	0	1	X	40'	0	0	WS	0	WS	1	WS	1	X
				16"	24'	0	0	0	0	0	0	0	0	WS	26'	0	0	0	0	0	WS	0	0	WS	28'	0	0	0	0	0	WS	0	0	WS	30'	0	0	0	0	0	WS	0	WS	WS	32'	0	0	0	0	0	WS	0	WS	1	34'	0	0	WS	0	0	WS	0	WS	1	36'	0	0	WS	0	WS	WS	0	WS	1	38'	0	0	WS	0	WS	WS	WS	WS	1	40'	0	0	WS	0	WS	1	WS	WS

AJS® Joist Series	Joist Depth	Roof Truss Span	Roof Total Load (PSF)																																																																																										
			35			45			55																																																																																				
			16"	19.2"	24"	16"	19.2"	24"	16"	19.2"	24"																																																																																		
190	9½"	24'	0	0	1	0	0	2	0	2	X	26'	0	0	1	0	1	X	1	2	X	28'	0	0	1	0	1	X	1	X	X	30'	0	0	2	0	2	X	1	X	X	32'	0	0	2	1	2	X	2	X	X	34'	0	1	X	1	2	X	2	X	X	36'	0	1	X	1	X	X	X	X	X	38'	0	1	X	2	X	X	X	X	X	40'	0	2	X	2	X	X	X	X	X		
		11½"	24'	0	0	0	0	0	WS	0	0	1	26'	0	0	0	0	0	1	0	0	2	28'	0	0	0	0	0	1	0	1	X	30'	0	0	0	0	0	1	0	1	X	32'	0	0	WS	0	0	2	0	1	X	34'	0	0	1	0	0	X	0	1	X	36'	0	0	1	0	1	X	1	2	X	38'	0	0	1	0	1	X	1	X	X	40'	0	0	1	0	1	X	1	X	X	
			14"	24'	0	0	0	0	0	0	0	0	WS	26'	0	0	0	0	0	WS	0	0	WS	28'	0	0	0	0	0	WS	0	WS	1	30'	0	0	0	0	0	WS	0	WS	1	32'	0	0	0	0	0	WS	0	WS	1	34'	0	0	WS	0	0	1	0	WS	X	36'	0	0	WS	0	WS	1	0	1	X	38'	0	0	WS	0	WS	1	WS	1	X	40'	0	0	WS	0	WS	1	WS	1	X
				16"	24'	0	0	0	0	0	0	0	0	WS	26'	0	0	0	0	0	WS	0	0	WS	28'	0	0	0	0	0	WS	0	0	WS	30'	0	0	0	0	0	WS	0	WS	WS	32'	0	0	0	0	0	WS	0	WS	1	34'	0	0	WS	0	0	WS	0	WS	1	36'	0	0	WS	0	WS	WS	0	WS	1	38'	0	0	WS	0	WS	WS	WS	WS	1	40'	0	0	WS	0	WS	1	WS	WS

AJS® Joist Series	Joist Depth	Roof Truss Span	Roof Total Load (PSF)																																																																																										
			35			45			55																																																																																				
			16"	19.2"	24"	16"	19.2"	24"	16"	19.2"	24"																																																																																		
25	9½"	24'	0	0	1	0	0	X	0	2	X	26'	0	0	1	0	1	X	1	X	X	28'	0	0	2	0	1	X	1	X	X	30'	0	0	2	0	2	X	2	X	X	32'	0	0	X	1	2	X	2	X	X	34'	0	1	X	1	X	X	X	X	X	36'	0	1	X	1	X	X	X	X	X	38'	0	2	X	2	X	X	X	X	X	40'	0	2	X	2	X	X	X	X	X		
		11½"	24'	0	0	0	0	0	0	0	0	2	26'	0	0	0	0	0	1	0	0	2	28'	0	0	0	0	0	1	0	1	X	30'	0	0	0	0	0	2	0	1	X	32'	0	0	0	0	0	2	0	1	X	34'	0	0	1	0	0	2	0	2	X	36'	0	0	1	0	1	X	1	2	X	38'	0	0	1	0	1	X	1	X	X	40'	0	0	2	0	1	X	1	X	X	
			14"	24'	0	0	0	0	0	0	0	0	0	26'	0	0	0	0	0	0	0	0	0	28'	0	0	0	0	0	0	0	0	1	30'	0	0	0	0	0	0	0	0	1	32'	0	0	0	0	0	0	0	0	2	34'	0	0	0	0	0	0	1	0	2	36'	0	0	0	0	0	1	0	1	2	38'	0	0	0	0	0	1	0	1	X	40'	0	0	0	0	0	2	0	1	X
				16"	24'	0	0	0	0	0	0	0	0	0	26'	0	0	0	0	0	0	0	0	0	28'	0	0	0	0	0	0	0	0	WS	30'	0	0	0	0	0	0	0	0	WS	32'	0	0	0	0	0	0	0	0	1	34'	0	0	0	0	0	0	0	0	1	36'	0	0	0	0	0																							

Reinforced Load-Bearing Cantilever Details

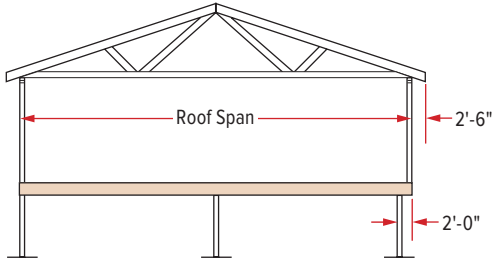

► The tables and details on pages 8 and 9 indicate the type of reinforcements, if any, that are required for load-bearing cantilevers up to a maximum length of 2'-0". Cantilevers longer than 2'-0" cannot be reinforced. However, longer cantilevers with lower loads may be allowable without reinforcement. Analyze specific applications with the BC Calc® software.

PLYWOOD/OSB REINFORCEMENT (If required, per table on page 8 or per BC Calc® analysis)

- 2³/₃₂" min. x 48" long plywood/OSB rated sheathing must match the full depth of the AJS® joist. Nail to the AJS® joist with 8d nails at 6" o.c. and nail with 4-8d nails into backer block. When reinforcing both sides, stagger nails to limit splitting. Install with face grain horizontal.
- The tables on page 8 assume a wall weight of 100 PLF, in addition to the roof loading shown. Applications with loading that exceeds the loads shown shall be analyzed with BC Calc® software.
- Contact Boise Cascade EWP Engineering for reinforcement requirements on AJS® joist depths greater than 16".

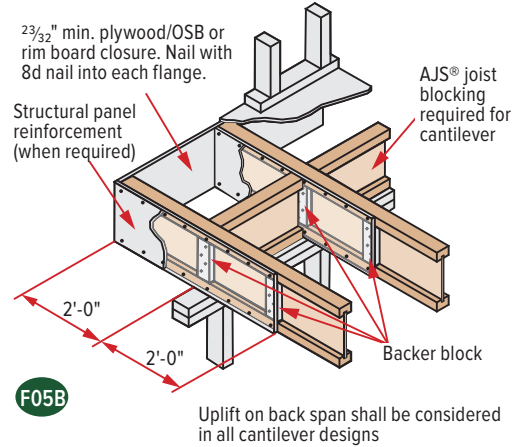

Uplift on back span shall be considered in all cantilever designs

Brick Ledge Load-Bearing Cantilever

F20A

Brick Ledge With Blocking Panels

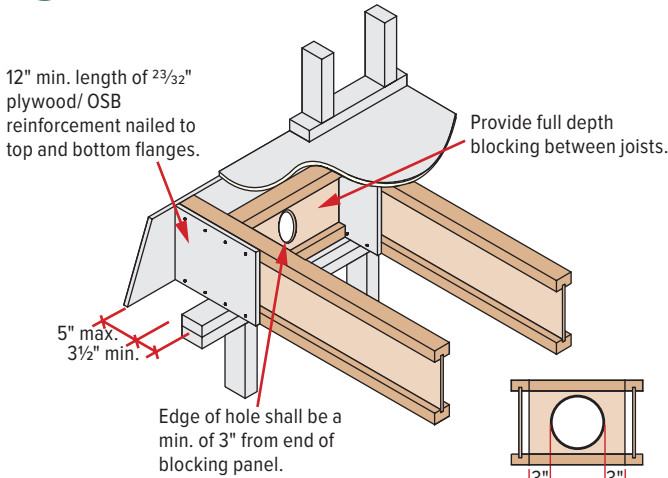

- Use 2³/₃₂" min plywood/OSB rated sheathing. Install full depth of joist with face grain parallel to joist. Plywood reinforcement to bear fully on wall plate. Nail plywood to top and bottom joist flanges with 2¹/₂" (8d) nails at 3" on center except 9¹/₂" joists, install nails at 2¹/₂" on center.
- Provide full depth blocking between joists.
- Edge of hole shall be at a minimum of 3" from end of blocking panel.

F20B

Brick Ledge Without Blocking Panels

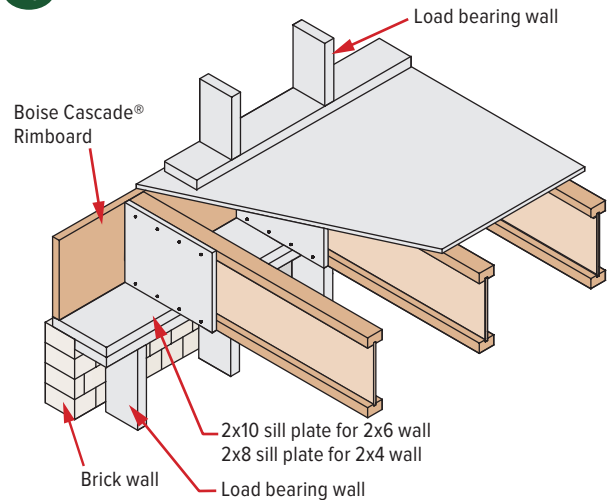

- Use 2³/₃₂" min plywood/OSB rated sheathing. Install full depth of joist with face grain parallel to joist. Plywood reinforcement to bear fully on wall plate. Nail plywood to top and bottom joist flanges with 2¹/₂" (8d) nails at 3" on center except 9¹/₂" joists, install nails at 2¹/₂" on center.
- See page 27 for joist and rimboard connection details.

Joist Depth	Roof Truss Span	Roof Live Load (PSF)												
		20			30			40			50			
		12"	16"	19.2"	12"	16"	19.2"	12"	16"	19.2"	12"	16"	19.2"	
9 1/2"	24'	0	0	0	0	0	0	1	0	1	1	0	1	1
	26'	0	0	0	0	0	1	0	1	1	0	1	2	
	28'	0	0	0	0	0	1	0	1	1	0	1	2	
	30'	0	0	0	0	0	1	0	1	1	1	1	2	
	32'	0	0	1	0	1	1	0	1	2	1	2	2	
	34'	0	0	X	0	X	X	0	1	X	1	2	X	
11 7/8"	24'	0	X	X	0	X	X	1	X	X	1	X	X	
	26'	0	0	0	0	0	0	0	0	0	0	0	1	
	28'	0	0	0	0	0	0	0	0	0	1	0	1	
	30'	0	0	0	0	0	0	0	0	1	0	1	1	
	32'	0	0	0	0	0	0	0	0	1	0	1	1	
	34'	0	0	0	0	1	1	0	1	1	0	1	1	
14"	24'	0	0	0	0	1	1	0	1	1	0	1	X	
	26'	0	0	0	0	0	0	0	0	0	0	0	0	
	28'	0	0	0	0	0	0	0	0	0	0	0	0	
	30'	0	0	0	0	0	0	0	0	0	0	0	1	
	32'	0	0	0	0	0	0	0	0	0	0	0	1	
	34'	0	0	0	0	0	0	0	0	1	0	0	1	
14"	36'	0	0	0	0	0	0	0	0	1	0	1	X	

Brick Ledge Reinforcement Table

Table Design Assumptions

Roof Loading: 15 psf dead load plus a 100 PLF wall self-weight, in addition to roof live load shown. Maximum 2'-6" overhangs assumed on roof trusses.

Floor Loading: 40 psf live load plus 10 psf dead load, backspans not to exceed maximum floor spans shown on page 4.

KEY TO TABLES

- 0 = No reinforcement required
- 1 = Reinforcement required on one side of joist
- 2 = Reinforcement required on both sides of joist
- X = Use deeper joists or closer spacing

Non-Load-Bearing Wall Cantilever Details

▶ AJS® Joists are intended only for applications that provide permanent protection from the weather. Impervious moisture barrier systems shall be detailed and installed in details F15A and F15B in accordance with 2018 IBC® Sections 107.2.5 and 110.3.6, or 2021 IBC Sections 107.2.5 and 110.3.7.

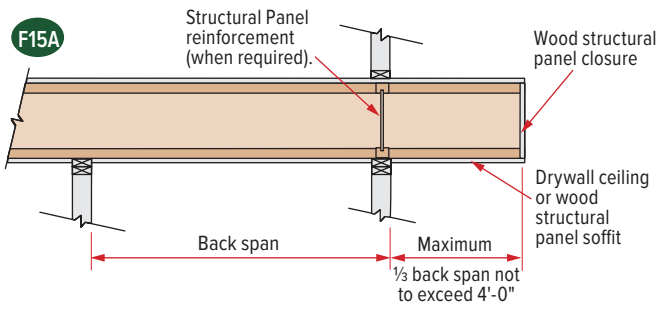

▶ These details apply to cantilevers with uniform loads only.
▶ Analyze AJS® joist cantilever condition with BC Calc® software.

▶ Fasten the 2x8 minimum to the AJS® joist by nailing through the backer block and joist web with two rows of 10d nails at 6" o.c. Clinch all nails. For AJS® 25/30 joists, use two rows of 16d nails on each side (four rows total) at 6" o.c.

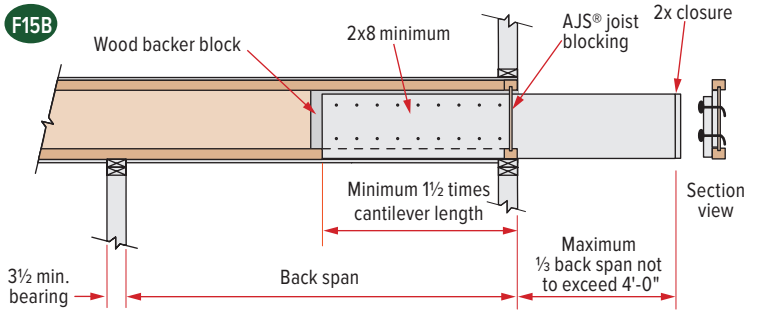

▶ Loading shall not exceed 60 PSF live load and 10 PSF dead load. At least three joist members shall be present and spaced at 24" o.c. or less.
▶ Lumber joist shall be No. 2 Dense Southern Pine, No.1/No.2 SPF, No.2 Hem-fir, or No.2 Douglas fir, or higher grade.
▶ Provide positive drainage, durable materials, and venting as required in 2018 IBC Sections 2304.12.2.5 and 2304.12.2.6, or 2021 IBC Sections 2304.12.2.4 and 2304.12.2.5.. Lumber joist shall be sloped.

Web Stiffener Requirements

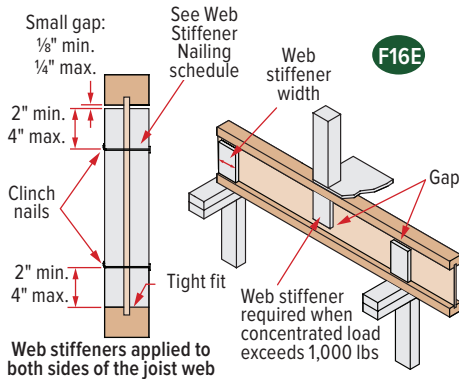

NOTES

Web stiffeners are optional except as noted below.

- ▶ Web stiffeners are always required:
 - for all 18" and deeper joists at all bearing locations.
 - in hangers that do not extend up to support the top flange of the AJS® joist. Web stiffeners may be required with certain sloped or skewed hangers or to achieve uplift values. Refer to the hanger manufacturer's installation requirements.
 - in certain roof applications. See Roof Framing Details on page 15.
 - under concentrated loads that exceed 1,000 pounds. Install the web stiffeners snug to the top flange in this situation. Follow the nailing schedule for intermediate bearings.
 - when hanger does not laterally support the top flange (e.g., adjustable height hangers). Web stiffeners may be of multiple thickness (e.g., AJS® 20, double 1/2" panel OK).
 - as needed for structural capacity, to increase the AJS® joist's reaction capacity at a specific bearing location.

▶ Web stiffeners may be cut from structural rated wood panels, engineered rimboard or 2x lumber (AJS® 25 only).

▶ Web stiffeners may be used to increase allowable reaction values. See AJS® Joist Design Properties on page 26 or use BC Calc® software.

Web Stiffener Nailing Schedule

AJS® Joist		Nailing
Series	Depth	
140	9½"–11⅞"	Three 10d
150		
20		
190	14"–16"	Five 10d
25		

Web Stiffener Specifications

AJS® Joist Series	For Structural Capacity (Min. Thick)	Lateral Restraint in Hanger	Minimum Width
140	1"	1"	2⅝"
150			
20			
190			
25	2x4 lumber (vertical)		

Large Rectangular Holes

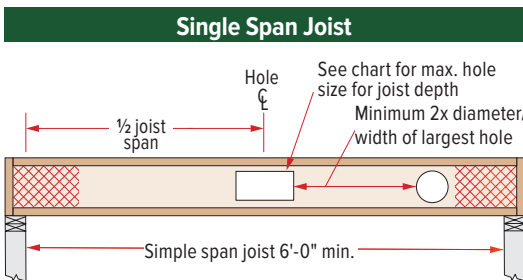

▶ Hole sizes in table (right) are based on maximum uniform load of 40 psf live load and 15 psf dead load, at maximum spacing of 24" on-center.
▶ Additional holes may be cut in the web provided they meet the specifications shown in the Minimum Distance hole chart on page 7, or as allowed using BC Calc® sizing software.

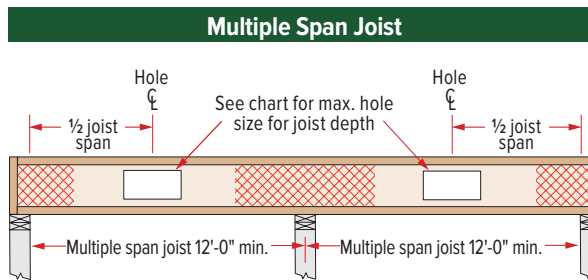

Maximum Hole Size

Joist Depth	Simple Span	Multiple Span
9½"	6" x 12"	6" x 7"
11⅞"	8" x 13"	8" x 8"
14"	9" x 16" 10" x 14"	8" x 13" 9" x 11"
16"	11" x 16" 12" x 15"	10" x 14" 11" x 12"

Larger holes may be possible for either single or multiple span joists; use BC Calc® sizing software for specific analysis.

Floor Load Tables

Allowable Uniform Floor Load (in pounds per lineal foot [PLF])

100% Load Duration

Span Length	AJS® 140 2½" Flange Width								AJS® 150 2½" Flange Width							
	9½"		11⅞"		14"		16"		9½"		11⅞"		14"		16"	
	Live Load	Total Load	Live Load	Total Load	Live Load	Total Load	Live Load	Total Load	Live Load	Total Load	Live Load	Total Load	Live Load	Total Load	Live Load	Total Load
6	–	313	–	318	–	320	–	323	–	313	–	318	–	320	–	323
7	–	268	–	272	–	274	–	277	–	268	–	272	–	274	–	277
8	–	235	–	238	–	240	–	242	–	235	–	238	–	240	–	242
9	–	208	–	212	–	213	–	215	–	208	–	212	–	213	–	215
10	170	188	–	191	–	192	–	194	180	188	–	191	–	192	–	194
11	131	161	–	173	–	174	–	176	139	170	–	173	–	174	–	176
12	103	136	–	159	–	160	–	161	109	156	–	159	–	160	–	161
13	82	115	136	146	–	147	–	149	87	133	144	146	–	147	–	149
14	67	100	111	129	–	137	–	138	71	115	117	136	–	137	–	138
15	55	87	91	112	–	128	–	129	58	100	97	127	–	128	–	129
16	46	76	76	99	110	119	–	121	48	88	81	114	116	120	–	121
17			64	87	93	105	–	114	41	78	68	101	98	112	–	114
18			54	78	79	94	106	107			58	90	84	106	–	107
19			46	70	68	84	91	98			49	80	72	97	96	102
20			40	63	58	76	79	88			43	73	62	87	83	97
21					51	69	68	80					54	79	73	92
22					44	63	60	73					47	72	64	84
23							53	67					41	66	56	76
24							47	61							49	70
25							41	56							44	65
26																
27																
28																
29																
30																

NOTES

- ▶ This table was designed to apply to a broad range of applications. It may be possible to exceed the limitations of this table by analyzing a specific application with the BC Calc® software.
- ▶ Live Load values are limited by deflection equal to L/480. For deflection limits of L/360 and L/960, multiply the Live Load values by 1.33 and 0.50 respectively.
- ▶ Total Load values are limited by shear, moment, or deflection equal to L/240.
- ▶ Both the Total Load and Live Load columns must be checked. Where a Live Load value is not shown, the Total Load value will control.

- ▶ Total Load values assume minimum bearing lengths without web stiffeners for joist depths of 16" and less. Web stiffeners are required for 18" or 20" joists.
- ▶ Table values
 - apply to either simple or multiple span joists. Span is measured center to center of the minimum required bearing length. Analyze multiple span joists with the BC Calc® software if the length of any span is less than half the length of an adjacent span.
 - do not consider composite action from gluing and nailing floor sheathing (composite action is considered in floor span tables on page 4).
- ▶ For assistance with floor design, consult the section About Floor Performance on page 4.

Floor Load Tables

Allowable Uniform Floor Load (in pounds per lineal foot [PLF])

100% Load Duration

Span Length	AJS® 20 2½" Flange Width								AJS® 190 2½" Flange Width							
	9½"		11⅞"		14"		16"		9½"		11⅞"		14"		16"	
	Live Load	Total Load	Live Load	Total Load	Live Load	Total Load	Live Load	Total Load	Live Load	Total Load	Live Load	Total Load	Live Load	Total Load	Live Load	Total Load
6	–	313	–	318	–	320	–	323	–	313	–	318	–	320	–	323
7	–	268	–	272	–	274	–	277	–	268	–	272	–	274	–	277
8	–	235	–	238	–	240	–	242	–	235	–	238	–	240	–	242
9	–	208	–	212	–	213	–	215	–	208	–	212	–	213	–	215
10	–	188	–	191	–	192	–	194	–	188	–	191	–	192	–	194
11	161	170	–	173	–	174	–	176	168	170	–	173	–	174	–	176
12	128	156	–	159	–	160	–	161	133	156	–	159	–	160	–	161
13	102	144	–	146	–	147	–	149	107	144	–	146	–	147	–	149
14	83	134	–	136	–	137	–	138	87	134	–	136	–	137	–	138
15	69	120	113	127	–	128	–	129	72	125	118	127	–	128	–	129
16	57	106	95	119	–	120	–	121	60	117	99	119	–	120	–	121
17	48	93	80	112	–	112	–	114	50	101	83	112	–	112	–	114
18	41	82	68	106	98	106	–	107	43	86	71	106	102	106	–	107
19			58	97	84	101	–	102			61	100	88	101	–	102
20			50	88	73	96	–	97			53	95	76	96	–	97
21			44	79	63	91	85	92			46	90	66	91	89	92
22					55	87	74	88			40	80	58	87	78	88
23					49	80	65	84					51	83	69	84
24					43	73	58	80					45	80	61	80
25							52	77					40	76	54	77
26							46	72							48	74
27							41	67							43	71
28																
29																
30																

NOTES

- ▶ Total Load values are limited by shear, moment, or deflection equal to L/240.
- ▶ Live Load values are limited by deflection equal to L/480. For deflection limits of L/360 and L/960, multiply the Live Load values by 1.33 and 0.50 respectively.
- ▶ Both the Total Load and Live Load columns must be checked. Where a Live Load value is not shown, the Total Load value will control.
- ▶ Table values apply to either simple or multiple span joists. Span is measured center to center of the minimum required bearing length. Analyze multiple span joists with the BC Calc® software if the length of any span is less than half the length of an adjacent span.
- ▶ Table values do not consider composite action from gluing and nailing floor sheathing (composite action is considered in floor span tables on page 4).
- ▶ Total Load values assume minimum bearing lengths without web stiffeners for joist depths of 16" and less.
- ▶ For assistance with floor design, consult the section *About Floor Performance* on page 4.
- ▶ This table was designed to apply to a broad range of applications. It may be possible to exceed the limitations of this table by analyzing a specific application with the BC Calc® software.

Floor Load Tables

Allowable Uniform Floor Load (in pounds per lineal foot (PLF))

100% Load Duration								
Span Length	AJS® 25 3½" Flange Width							
	9½"		11⅞"		14"		16"	
	Live Load	Total Load	Live Load	Total Load	Live Load	Total Load	Live Load	Total Load
6	–	450	–	453	–	320	–	323
7	–	385	–	388	–	274	–	277
8	–	337	–	340	–	240	–	242
9	–	300	–	302	–	213	–	215
10	–	270	–	272	–	192	–	194
11	–	245	–	247	–	174	–	176
12	–	225	–	226	–	160	–	161
13	136	207	–	209	–	147	–	149
14	111	192	–	194	–	137	–	138
15	92	180	–	181	–	128	–	129
16	77	168	–	170	–	120	–	121
17	65	158	150	160	–	112	–	114
18	55	150	150	151	–	106	–	107
19	47	142	129	143	–	101	–	102
20	41	135	112	136	–	96	–	97
21			86	129	85	91	–	92
22			90	123	74	87	–	88
23			76	118	66	83	–	84
24			68	113	58	80	78	80
25					52	76	69	77
26					46	73	62	74
27					41	71	56	71
28							50	69
29							45	66
30							41	64

NOTES

- ▶ Total Load values are limited by shear, moment, or deflection equal to L/240.
- ▶ Live Load values are limited by deflection equal to L/480. For deflection limits of L/360 and L/960, multiply the Live Load values by 1.33 and 0.50 respectively.
- ▶ Both the Total Load and Live Load columns must be checked. Where a Live Load value is not shown, the Total Load value will control.
- ▶ Table values apply to either simple or multiple span joists. Span is measured center to center of the minimum required bearing length. Analyze multiple span joists with the BC Calc® software if the length of any span is less than half the length of an adjacent span.
- ▶ Table values do not consider composite action from gluing and nailing floor sheathing (composite action is considered in floor span tables on page 4).
- ▶ Total Load values assume minimum bearing lengths without web stiffeners for joist depths of 16" and less.
- ▶ For assistance with floor design, consult the section *About Floor Performance* on page 4.
- ▶ This table was designed to apply to a broad range of applications. It may be possible to exceed the limitations of this table by analyzing a specific application with the BC Calc® software.

Roof Framing

AJS Rafter

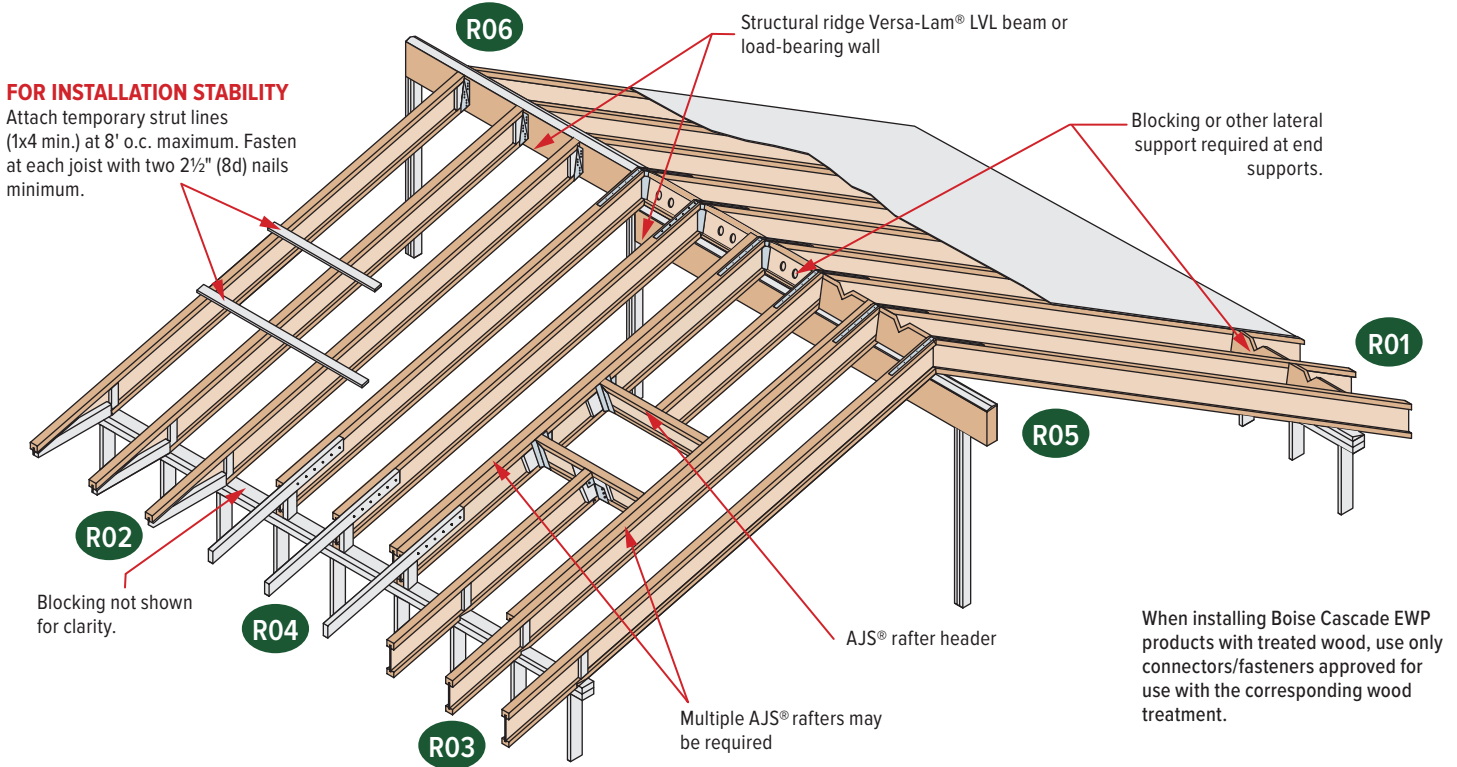

SAFETY WARNING

DO NOT ALLOW WORKERS ON AJS® JOISTS UNTIL ALL HANGERS, AJS® RIM JOISTS, RIM BOARDS, AJS® BLOCKING PANELS, X-BRACING AND TEMPORARY 1x4 STRUT LINES ARE INSTALLED AS SPECIFIED BELOW. SERIOUS ACCIDENTS CAN RESULT FROM INSUFFICIENT ATTENTION TO PROPER BRACING DURING CONSTRUCTION. ACCIDENTS CAN BE AVOIDED UNDER NORMAL CONDITIONS BY FOLLOWING THE GUIDELINES BELOW.

- ▶ Build a braced end wall at the end of the bay, or permanently install the first eight feet of AJS® joists and the first course of sheathing. As an alternate, temporary sheathing may be nailed to the first four feet of AJS® joists at the end of the bay.
- ▶ All hangers, AJS® rim joists, rim boards, AJS® blocking panels, and x-bracing must be completely installed and properly nailed as each AJS® joist is set.
- ▶ Install temporary 1x4 strut lines at no more than eight feet on-center as additional AJS® joists are set. Nail the strut lines to the sheathed area, or braced end wall, and to each AJS® joist with two 2½" (8d) nails.
- ▶ The ends of cantilevers must be temporarily secured by strut lines on both the top and bottom flanges.
- ▶ Straighten the AJS® joist to within ½" of true alignment before attaching strut lines and sheathing.
- ▶ Remove the temporary strut lines only as required to install the permanent sheathing.
- ▶ Failure to install temporary bracing may result in sideways buckling or roll-over under light construction loads.

AJS® Ceiling Joist with Bevel End Cut (For limited-access attics only)

CAUTION: DO NOT use AJS® joists as a collar/tension tie. Roof rafters shall be supported by ridge beam or other upper bearing support.

NOTES:

- ▶ Ceiling joist must be designed to carry all roof load transferred through rafter struts as shown.
- ▶ AJS® ceiling joist end reaction may not exceed 550 pounds.
- ▶ Minimum roof slope is 6:12.
- ▶ Detail is to be used only for ceiling joists with no access to attic space.
- ▶ Nail roof rafter to AJS® top flange with one 3" (10d) sinker or box nail.
- ▶ 1x4 nailers must be continuous and nailed to a braced end wall.
- ▶ Install a 24" long web stiffener on each side of AJS® joist at beveled ends. Nail roof rafter to AJS® joist per building code requirements for ceiling joist to roof rafter connection.

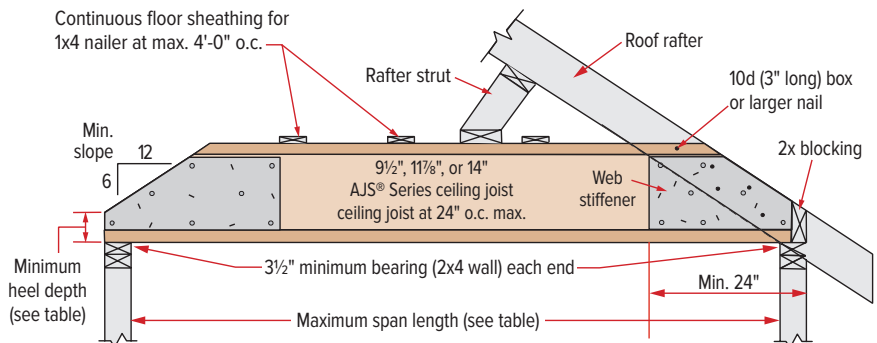

Ceiling loads: Live Load 10 PSF Dead Load 7 PSF

Minimum Heel Depths

Joist Depth	End Wall	
	2 x 4	2 x 6
9½"	2½"	1½"
11⅞"	3½"	2½"
14"	4½"	3½"

Maximum Span Lengths Without Roof Loads

9½" AJS® 140, 150, 20, 190, 25	19'-6"
11⅞" AJS® 140, 150, 20, 190, 25	22'-0"
14" AJS® 140, 150, 20, 190, 25	24'-6"

▶ If roof loads are present, see first two notes at left.

Roof Framing Details

Additional roof framing details available with BC Framers® software

<p>R01</p> <p>2x beveled plate for slope greater than ¼:12</p> <p>Simpson Strong-Tie VPA or MiTek TMP connectors or equal can be used in lieu of beveled plate for slopes from 3:12 to 12:12.</p>	<p>R02</p> <p>Rim board/Versa-Lam® LVL blocking. Ventilation "V" cut: ½ of length, ½ of depth.</p> <p>2x4 blocking for soffit support</p> <p>16" max. joist depth for birdsmouth cut</p> <p>2'-6" max.</p> <p>AJS® joist flange may be birdsmouth cut only at the low end of the joist, and cut flange must bear fully on plate. Web stiffener required on each side.</p>	<p>R03</p> <p>Rim board/Versa-Lam® LVL blocking. Ventilation "V" cut: ½ of length, ½ of depth.</p> <p>Tight fit for lateral stability</p> <p>16" max. joist depth for birdsmouth cut</p> <p>2'-6" max.</p> <p>AJS® joist flange may be birdsmouth cut only at the low end of the joist, and cut flange must bear fully on plate. Web stiffener required on each side.</p>
<p>R04</p> <p>10d nails at 6" o.c.</p> <p>2x4 one side for 135 PLF max. 2x6 one side for 240 PLF max.</p> <p>Backer block: Thickness per corresponding AJS® joist series</p> <p>2x block</p> <p>AJS® joist blocking holes cut for ventilation</p> <p>4'0" horiz. 2'6" horiz.</p>	<p>R05</p> <p>Simpson Strong-Tie or MiTek LSTA24 strap, nail per governing building code</p> <p>AJS® blocking holes cut for ventilation</p> <p>Blocking on both sides of ridge may be required for shear transfer per design professional of record.</p> <p>Double-bevel wood plate</p> <p>Versa-Lam® LVL support beam</p>	<p>R06</p> <p>Simpson Strong-Tie or MiTek LSTA24 strap where slope exceeds 7:12 (straps may be required for lower slopes in high-wind areas). Nail per building code.</p> <p>Versa-Lam® LVL support beam</p> <p>Simpson Strong-Tie LSSUI or MiTek TMU hanger</p> <p>Beveled web stiffener on each side</p>
<p>R07</p> <p>Backer block (minimum 12" wide). Nail with ten 10d nails.</p> <p>Joist hanger</p> <p>Filler block: Nail with ten 10d nails.</p> <p>A backer block is required where top flange hanger load exceeds 250 lbs. All face mount hangers require backer blocks on both sides of the supporting joist's web. For top flange hangers install tight to top flange. For face mount hangers, install tight to the bottom flange.</p>	<p>R11</p> <p>Double joist may be required when L exceeds rafter spacing.</p> <p>Blocking as required</p> <p>Nail outrigger through AJS® joist web</p> <p>2" x _ outrigger notched around AJS® joist top flange. Outrigger spacing no greater than 24" o.c.</p> <p>2'-0" max. L. 2'-0" max. L.</p> <p>End wall</p>	<p>DN05</p> <p>DO NOT bevel-cut roof joist beyond the inside face of wall.</p>

Lateral Support

- ▶ AJS® joists must be laterally supported at the ends (including supports adjacent to overhangs) with hangers, rim board, or blocking (Versa-Lam LVL®, Boise Cascade® Rimboard, or AJS® joist). Metal cross bracing or other x-bracing provides adequate lateral support for AJS® joists. Consult governing building code for roof diaphragm connection provisions.

Minimum Bearing Length For AJS® Joists

- ▶ Minimum end bearing: 1½" for all AJS® joists. 3½" required at cantilever and intermediate supports.
- ▶ Longer bearing lengths allow higher reaction values. Refer to the building code evaluation report or the BC Calc® software.

Nailing Requirements

- ▶ **AJS® rim joist, rim board or closure panel to AJS® joist:**
 - **Rims or closure panel:** Two nails, one each in the top and bottom flange; Up to 1¼" thick rim, use 8d x 2½" nails.
 - **AJS® 140/150/20/190 rim joist:** Two 16d box nails, one each in the top and bottom flange.
 - **AJS® 25 rim joist:** Toe-nail top flange to rim joist with two 10d box nails, one each side of flange.
- ▶ **AJS® rim joist, rim board or AJS® blocking panel to support:**
 - Min. 8d nails at 6" o.c. per IRC®.
 - Connection per design professional of record's specification for shear transfer.

▶ AJS® joist to support:

- Two 8d nails, one on each side of the web, placed 1½" minimum from the end of the AJS® joist to limit splitting.

▶ Sheathing to AJS® joist:

- Prescriptive residential roof sheathing nailing requires 8d common nails at 6" o.c. on edges and at 12" o.c. in the field (IRC® Table R602.3(1)).
- See closest allowable nail spacing limits on page 24 for floor diaphragm nailing specified at closer spacing than IRC®.
- For full lateral stability, maximum nail spacing for bracing is 18" for AJS® 140/150/20/190, and 24" for larger AJS® joist series.
- 14 gauge staples may be substituted for 8d nails if the staples penetrate at least 1" into the joist.
- Wood screws may be acceptable, contact local building official and/or Boise Cascade EWP Engineering for more information.

Web Stiffeners

- ▶ See Web Stiffener Requirements on page 9.

Maximum Slope

- ▶ Unless otherwise noted, all roof details are valid for slopes of 12:12 or less.

Ventilation

- ▶ All 1½" prepunched knock-out holes spaced at 12" o.c. along the AJS® joist may be knocked out and used for cross ventilation. When designing ventilation, using deeper joists than what is structurally required may be an advantage. Consult local building officials and/or ventilation specialists for specific requirements.

Birdsmouth Cuts

- ▶ AJS® joists may be birdsmouth cut only at the low end support.
- ▶ AJS® joists with birdsmouth cuts may cantilever up to 2'-6" past the low end support.
- ▶ The bottom flange must sit fully on the support and may not overhang the inside face of the support.
- ▶ Birdsmouth cuts are NOT allowed at high end or intermediate supports.

Backer and Filler Block Dimensions

Series	Backer Block Thickness	Filler Block Thickness
140		
150	1½" or two ½" wood panels	2 x _ + 5/8" wood panel
20		
190		
25	2 x _ lumber	Double 2 x _ lumber

- ▶ Cut backer and filler blocks to a maximum depth equal to the web depth minus ¼" to avoid a forced fit.

Roof Span Tables

Maximum clear span in feet and inches, based on horizontal spans.

115% and 125% Load Duration

Condition			AJS® 140 – 2½" Flange Width												
			9½"			11⅞"			14"			16"			
O.C. Spacing and Load Duration	Live Load (psf)	Dead Load (psf)	4:12 or Less	4:12 to 8:12	8:12 to 12:12	4:12 or Less	4:12 to 8:12	8:12 to 12:12	4:12 or Less	4:12 to 8:12	8:12 to 12:12	4:12 or Less	4:12 to 8:12	8:12 to 12:12	
12" o.c.	Non-Snow 125%	20	10	25'-2"	23'-9"	22'-0"	30'-1"	28'-5"	26'-4"	34'-4"	32'-4"	30'-0"	37'-10"	35'-11"	33'-4"
		20	15	23'-10"	22'-5"	20'-8"	28'-6"	26'-9"	24'-9"	32'-5"	30'-6"	28'-2"	34'-11"	33'-10"	31'-3"
		20	20	22'-9"	21'-4"	19'-7"	27'-3"	25'-6"	23'-5"	30'-3"	29'-0"	26'-8"	32'-7"	31'-6"	29'-7"
	Snow 115%	25	10	23'-11"	22'-7"	21'-0"	28'-5"	27'-0"	25'-2"	31'-2"	30'-7"	28'-8"	33'-7"	32'-11"	31'-10"
		25	15	22'-10"	21'-6"	19'-10"	26'-6"	25'-8"	23'-9"	29'-1"	28'-4"	27'-1"	31'-4"	30'-6"	29'-5"
		30	10	22'-10"	21'-8"	20'-2"	26'-7"	25'-11"	24'-2"	29'-2"	28'-8"	27'-6"	31'-6"	30'-11"	30'-2"
		30	15	21'-11"	20'-8"	19'-2"	25'-0"	24'-5"	22'-11"	27'-5"	26'-10"	25'-11"	29'-7"	28'-11"	28'-0"
		40	10	20'-10"	19'-11"	18'-10"	23'-9"	23'-5"	22'-6"	26'-2"	25'-9"	25'-3"	28'-2"	27'-9"	27'-2"
		40	15	19'-10"	19'-4"	18'-1"	22'-7"	22'-2"	21'-7"	24'-10"	24'-4"	23'-9"	26'-9"	26'-3"	25'-7"
		50	10	19'-0"	18'-6"	17'-6"	21'-8"	21'-5"	21'-0"	23'-10"	23'-7"	23'-2"	25'-8"	25'-5"	25'-0"
50	15	18'-3"	17'-11"	17'-2"	20'-10"	20'-6"	20'-0"	22'-10"	22'-6"	22'-0"	24'-8"	24'-3"	23'-8"		
16" o.c.	Non-Snow 125%	20	10	22'-10"	21'-6"	20'-0"	27'-4"	25'-9"	23'-11"	30'-5"	29'-4"	27'-3"	32'-9"	32'-0"	30'-3"
		20	15	21'-7"	20'-3"	18'-9"	25'-6"	24'-3"	22'-5"	28'-1"	27'-2"	25'-6"	30'-3"	29'-4"	28'-2"
		20	20	20'-7"	19'-3"	17'-9"	23'-10"	23'-0"	21'-3"	26'-2"	25'-3"	24'-1"	28'-2"	27'-3"	26'-0"
	Snow 115%	25	10	21'-7"	20'-6"	19'-1"	24'-7"	24'-1"	22'-10"	27'-0"	26'-5"	25'-8"	29'-1"	28'-6"	27'-8"
		25	15	20'-1"	19'-5"	18'-0"	22'-11"	22'-4"	21'-6"	25'-2"	24'-6"	23'-8"	27'-1"	26'-5"	25'-6"
		30	10	20'-2"	19'-7"	18'-3"	23'-0"	22'-7"	21'-11"	25'-3"	24'-10"	24'-2"	27'-3"	26'-9"	26'-1"
		30	15	18'-11"	18'-6"	17'-5"	21'-7"	21'-1"	20'-5"	23'-9"	23'-2"	22'-5"	25'-7"	25'-0"	24'-2"
		40	10	18'-0"	17'-9"	17'-1"	20'-7"	20'-3"	19'-10"	22'-7"	22'-3"	21'-10"	24'-4"	24'-0"	23'-6"
		40	15	17'-2"	16'-10"	16'-4"	19'-7"	19'-2"	18'-8"	21'-6"	21'-1"	20'-6"	23'-2"	22'-8"	22'-1"
		50	10	16'-5"	16'-3"	15'-10"	18'-9"	18'-6"	18'-3"	20'-7"	20'-4"	20'-0"	22'-3"	22'-11"	21'-7"
50	15	15'-9"	15'-6"	15'-2"	18'-0"	17'-8"	17'-3"	19'-9"	19'-5"	19'-0"	21'-4"	20'-11"	20'-6"		
19.2" o.c.	Non-Snow 125%	20	10	21'-5"	20'-3"	18'-9"	25'-3"	24'-2"	22'-5"	27'-9"	27'-1"	25'-7"	29'-10"	29'-2"	28'-3"
		20	15	20'-3"	19'-1"	17'-7"	23'-3"	22'-7"	21'-1"	25'-7"	24'-10"	23'-10"	27'-7"	26'-9"	25'-8"
		20	20	19'-1"	18'-1"	16'-8"	21'-9"	21'-0"	19'-11"	23'-10"	23'-0"	22'-0"	25'-9"	24'-10"	23'-8"
	Snow 115%	25	10	19'-8"	19'-3"	17'-11"	22'-5"	21'-11"	21'-4"	24'-7"	24'-1"	23'-5"	26'-6"	26'-0"	25'-3"
		25	15	18'-4"	17'-10"	16'-11"	20'-11"	20'-4"	19'-7"	22'-11"	22'-4"	21'-7"	24'-9"	24'-1"	23'-3"
		30	10	18'-5"	18'-1"	17'-2"	21'-0"	20'-7"	20'-1"	23'-0"	22'-7"	22'-1"	24'-10"	24'-5"	23'-9"
		30	15	17'-3"	16'-10"	16'-4"	19'-8"	19'-3"	18'-7"	21'-8"	21'-2"	20'-6"	23'-4"	22'-9"	22'-1"
		40	10	16'-5"	16'-2"	15'-10"	18'-9"	18'-6"	18'-1"	20'-7"	20'-4"	19'-11"	22'-2"	21'-11"	21'-5"
		40	15	15'-8"	15'-4"	14'-11"	17'-10"	17'-6"	17'-0"	19'-7"	19'-2"	18'-8"	21'-1"	20'-8"	20'-2"
		50	10	15'-0"	14'-10"	14'-7"	17'-1"	16'-11"	16'-7"	18'-10"	18'-7"	18'-3"	20'-3"	20'-0"	19'-8"
50	15	14'-4"	14'-2"	13'-10"	16'-5"	16'-1"	15'-9"	18'-0"	17'-9"	17'-4"	19'-5"	19'-1"	18'-8"		
24" o.c.	Non-Snow 125%	20	10	19'-9"	18'-9"	17'-5"	22'-6"	22'-0"	20'-10"	24'-9"	24'-2"	23'-5"	26'-8"	26'-1"	25'-3"
		20	15	18'-3"	17'-8"	16'-3"	20'-10"	20'-2"	19'-4"	22'-10"	22'-2"	21'-3"	24'-7"	23'-11"	22'-11"
		20	20	17'-0"	16'-5"	15'-5"	19'-5"	18'-9"	17'-10"	21'-4"	20'-7"	19'-8"	23'-0"	22'-2"	21'-2"
	Snow 115%	25	10	17'-7"	17'-2"	16'-7"	20'-0"	19'-7"	19'-1"	22'-0"	21'-6"	20'-11"	23'-8"	23'-3"	22'-7"
		25	15	16'-4"	15'-11"	15'-4"	18'-8"	18'-2"	17'-6"	20'-6"	20'-0"	19'-3"	22'-1"	21'-6"	20'-9"
		30	10	16'-5"	16'-1"	15'-9"	18'-9"	18'-5"	17'-11"	20'-7"	20'-2"	19'-8"	22'-2"	21'-9"	21'-3"
		30	15	15'-5"	15'-1"	14'-7"	17'-7"	17'-2"	16'-8"	19'-4"	18'-11"	18'-3"	20'-10"	20'-4"	19'-8"
		40	10	14'-8"	14'-6"	14'-2"	16'-9"	16'-6"	16'-2"	18'-5"	18'-2"	17'-9"	19'-10"	19'-7"	19'-2"
		40	15	13'-11"	13'-8"	13'-4"	15'-11"	15'-7"	15'-2"	17'-6"	17'-2"	16'-8"	18'-10"	18'-6"	18'-0"
		50	10	13'-5"	13'-3"	13'-0"	15'-3"	15'-1"	14'-10"	16'-9"	16'-7"	16'-4"	18'-1"	17'-11"	17'-5"
50	15	12'-10"	12'-7"	12'-4"	14'-8"	14'-5"	14'-1"	16'-1"	15'-10"	15'-5"	17'-0"	16'-5"	15'-8"		

NOTES

- ▶ Table values
 - are limited by shear, moment, total load deflection equal to L/180 and live load deflection equal to L/240. Check the local building code for other deflection limits that may apply.
 - represent the most restrictive of simple or multiple span applications. Analyze multiple span joists with the BC Calc® software if the length of any span is less than half the length of an adjacent span.
 - assume minimum bearing lengths without web stiffeners for joist depths of 16" and less.
- ▶ This table was designed to apply to a broad range of applications. It may be possible to exceed the limitations of this table by analyzing a specific application with the BC Calc® software.
- ▶ Slope roof joists at least ¼:12 to minimize ponding.
- ▶ Allowable spans and loads shall be adjusted and checked for wind load as required by local building code.

Roof Span Tables

Maximum clear span in feet and inches, based on horizontal spans.

115% and 125% Load Duration															
Condition			AJS® 150 – 2½" Flange Width												
			9½"			11½"			14"			16"			
O.C. Spacing and Load Duration	Live Load (psf)	Dead Load (psf)	4:12 or Less	4:12 to 8:12	8:12 to 12:12	4:12 or Less	4:12 to 8:12	8:12 to 12:12	4:12 or Less	4:12 to 8:12	8:12 to 12:12	4:12 or Less	4:12 to 8:12	8:12 to 12:12	
12" o.c.	Non-Snow 125%	20	10	25'-9"	24'-3"	22'-6"	30'-9"	29'-0"	26'-11"	35'-1"	33'-1"	30'-8"	38'-11"	36'-8"	34'-0"
		20	15	24'-4"	22'-10"	21'-1"	29'-2"	27'-5"	25'-3"	33'-2"	31'-2"	28'-9"	36'-10"	34'-7"	31'-11"
		20	20	23'-3"	21'-9"	20'-0"	27'-10"	26'-0"	23'-11"	31'-8"	29'-8"	27'-3"	34'-11"	32'-11"	30'-3"
	Snow 115%	25	10	24'-5"	23'-1"	21'-6"	29'-3"	27'-8"	25'-9"	33'-3"	31'-6"	29'-3"	36'-0"	34'-11"	32'-6"
		25	15	23'-3"	21'-11"	20'-4"	27'-11"	26'-3"	24'-4"	31'-2"	29'-11"	27'-8"	33'-7"	32'-9"	30'-9"
		30	10	23'-4"	22'-1"	20'-7"	27'-11"	26'-6"	24'-8"	31'-4"	30'-2"	28'-1"	33'-9"	33'-1"	31'-2"
		30	15	22'-5"	21'-1"	19'-7"	26'-10"	25'-3"	23'-6"	29'-5"	28'-9"	26'-9"	31'-9"	31'-0"	29'-8"
		40	10	21'-3"	20'-4"	19'-3"	25'-5"	24'-5"	23'-0"	28'-0"	27'-7"	26'-3"	30'-2"	29'-9"	29'-1"
		40	15	20'-11"	19'-9"	18'-5"	24'-3"	23'-8"	22'-1"	26'-8"	26'-1"	25'-2"	28'-8"	28'-2"	27'-5"
		50	10	19'-8"	18'-10"	17'-11"	23'-3"	22'-7"	21'-5"	25'-7"	25'-3"	24'-5"	27'-7"	27'-3"	26'-9"
50	15	19'-7"	18'-9"	17'-6"	22'-4"	21'-11"	21'-0"	24'-6"	24'-1"	23'-7"	26'-5"	26'-0"	25'-5"		
16" o.c.	Non-Snow 125%	20	10	23'-4"	22'-0"	20'-5"	27'-11"	26'-4"	24'-5"	31'-9"	30'-0"	27'-10"	35'-1"	33'-3"	30'-10"
		20	15	22'-1"	20'-9"	19'-2"	26'-5"	24'-10"	22'-11"	30'-1"	28'-3"	26'-1"	32'-5"	31'-4"	28'-11"
		20	20	21'-1"	19'-8"	18'-1"	25'-2"	23'-7"	21'-8"	28'-1"	26'-11"	24'-9"	30'-3"	29'-2"	27'-5"
	Snow 115%	25	10	22'-1"	20'-11"	19'-6"	26'-4"	25'-1"	23'-4"	28'-11"	28'-4"	26'-7"	31'-2"	30'-6"	29'-6"
		25	15	21'-1"	19'-10"	18'-5"	24'-7"	23'-9"	22'-0"	27'-0"	26'-3"	25'-1"	29'-1"	28'-4"	27'-4"
		30	10	21'-2"	20'-0"	18'-8"	24'-8"	24'-0"	22'-4"	27'-1"	26'-7"	25'-6"	29'-2"	28'-8"	27'-11"
		30	15	20'-3"	19'-1"	17'-9"	23'-2"	22'-8"	21'-3"	25'-5"	24'-10"	24'-1"	27'-5"	26'-9"	25'-11"
		40	10	19'-3"	18'-5"	17'-5"	22'-1"	21'-9"	20'-10"	24'-3"	23'-10"	23'-5"	26'-1"	25'-9"	25'-3"
		40	15	18'-5"	17'-11"	16'-8"	21'-0"	20'-7"	20'-0"	23'-0"	22'-7"	22'-0"	24'-10"	24'-4"	23'-8"
		50	10	17'-8"	17'-1"	16'-3"	20'-2"	19'-11"	19'-5"	22'-1"	21'-10"	21'-6"	23'-10"	23'-6"	23'-2"
50	15	16'-11"	16'-8"	15'-10"	19'-4"	19'-0"	18'-7"	21'-2"	20'-10"	20'-4"	22'-10"	22'-6"	21'-11"		
19.2" o.c.	Non-Snow 125%	20	10	21'-11"	20'-8"	19'-2"	26'-3"	24'-9"	22'-11"	29'-9"	28'-2"	26'-2"	32'-0"	31'-3"	29'-0"
		20	15	20'-9"	19'-6"	18'-0"	24'-10"	23'-4"	21'-6"	27'-5"	26'-7"	24'-6"	29'-7"	28'-8"	27'-2"
		20	20	19'-9"	18'-6"	17'-0"	23'-4"	22'-2"	20'-5"	25'-7"	24'-8"	23'-3"	27'-7"	26'-7"	25'-5"
	Snow 115%	25	10	20'-9"	19'-8"	18'-3"	24'-0"	23'-6"	21'-11"	26'-5"	25'-10"	24'-11"	28'-5"	27'-10"	27'-1"
		25	15	19'-8"	18'-8"	17'-3"	22'-5"	21'-10"	20'-8"	24'-7"	24'-0"	23'-1"	26'-6"	25'-10"	24'-11"
		30	10	19'-9"	18'-10"	17'-7"	22'-6"	22'-1"	21'-0"	24'-8"	24'-3"	23'-8"	26'-7"	26'-2"	25'-6"
		30	15	18'-7"	17'-11"	16'-8"	21'-2"	20'-8"	20'-0"	23'-3"	22'-8"	21'-11"	25'-0"	24'-5"	23'-8"
		40	10	17'-8"	17'-4"	16'-4"	20'-1"	19'-10"	19'-5"	22'-1"	21'-9"	21'-4"	23'-10"	23'-6"	23'-0"
		40	15	16'-9"	16'-5"	15'-8"	19'-2"	18'-9"	18'-3"	21'-0"	20'-7"	20'-1"	22'-8"	22'-2"	21'-7"
		50	10	16'-1"	15'-11"	15'-3"	18'-4"	18'-2"	17'-10"	20'-2"	19'-11"	19'-7"	21'-9"	21'-6"	21'-1"
50	15	15'-5"	15'-2"	14'-10"	17'-7"	17'-4"	16'-11"	19'-4"	19'-0"	18'-7"	20'-10"	20'-6"	19'-8"		
24" o.c.	Non-Snow 125%	20	10	20'-3"	19'-1"	17'-9"	24'-2"	22'-11"	21'-3"	26'-7"	25'-11"	24'-3"	28'-7"	27'-11"	26'-11"
		20	15	19'-2"	18'-0"	16'-8"	22'-4"	21'-7"	19'-11"	24'-6"	23'-9"	22'-8"	26'-5"	25'-7"	24'-7"
		20	20	18'-3"	17'-2"	15'-9"	20'-10"	20'-1"	18'-10"	22'-10"	22'-1"	21'-1"	24'-8"	23'-9"	22'-8"
	Snow 115%	25	10	18'-10"	18'-2"	16'-11"	21'-6"	21'-0"	20'-3"	23'-7"	23'-1"	22'-5"	25'-5"	24'-11"	24'-2"
		25	15	17'-7"	17'-1"	16'-0"	20'-0"	19'-6"	18'-10"	22'-0"	21'-5"	20'-8"	23'-8"	23'-1"	22'-3"
		30	10	17'-8"	17'-4"	16'-3"	20'-1"	19'-9"	19'-3"	22'-1"	21'-8"	21'-2"	23'-9"	23'-4"	22'-9"
		30	15	16'-7"	16'-2"	15'-5"	18'-11"	18'-5"	17'-10"	20'-9"	20'-3"	19'-7"	22'-4"	21'-10"	21'-1"
		40	10	15'-9"	15'-6"	15'-2"	18'-0"	17'-8"	17'-4"	19'-9"	19'-5"	19'-1"	21'-3"	20'-11"	20'-6"
		40	15	15'-0"	14'-8"	14'-4"	17'-1"	16'-9"	16'-4"	18'-9"	18'-5"	17'-11"	20'-1"	19'-3"	18'-3"
		50	10	14'-5"	14'-2"	14'-0"	16'-5"	16'-2"	15'-11"	18'-0"	17'-9"	17'-2"	18'-6"	18'-0"	17'-5"
50	15	13'-9"	13'-7"	13'-3"	15'-9"	15'-5"	15'-1"	16'-9"	16'-2"	15'-5"	17'-0"	16'-5"	15'-8"		

NOTES

- ▶ Table values
 - are limited by shear, moment, total load deflection equal to L/180 and live load deflection equal to L/240. Check the local building code for other deflection limits that may apply.
 - represent the most restrictive of simple or multiple span applications. Analyze multiple span joists with the BC Calc® software if the length of any span is less than half the length of an adjacent span.
 - assume minimum bearing lengths without web stiffeners for joist depths of 16" and less.
- ▶ This table was designed to apply to a broad range of applications. It may be possible to exceed the limitations of this table by analyzing a specific application with the BC Calc® software.
- ▶ Slope roof joists at least ¼:12 to minimize ponding.
- ▶ Allowable spans and loads shall be adjusted and checked for wind load as required by local building code.

Roof Span Tables

Maximum clear span in feet and inches, based on horizontal spans.

115% and 125% Load Duration

Condition			AJS® 20 — 2½" Flange Width												
			9½"			11⅞"			14"			16"			
O.C. Spacing and Load Duration	Live Load (psf)	Dead Load (psf)	4:12 or Less	4:12 to 8:12	8:12 to 12:12	4:12 or Less	4:12 to 8:12	8:12 to 12:12	4:12 or Less	4:12 to 8:12	8:12 to 12:12	4:12 or Less	4:12 to 8:12	8:12 to 12:12	
12" o.c.	Non-Snow 125%	20	10	27'-4"	25'-9"	23'-11"	32'-7"	30'-9"	28'-7"	37'-1"	35'-0"	32'-6"	41'-2"	38'-10"	36'-0"
		20	15	25'-10"	24'-3"	22'-5"	30'-11"	29'-0"	26'-9"	35'-2"	33'-0"	30'-5"	39'-0"	36'-7"	33'-9"
		20	20	24'-8"	23'-1"	21'-3"	29'-6"	27'-7"	25'-4"	33'-6"	31'-5"	28'-10"	37'-2"	34'-10"	32'-0"
	Snow 115%	25	10	25'-11"	24'-6"	22'-10"	31'-0"	29'-3"	27'-3"	35'-3"	33'-4"	31'-0"	39'-1"	36'-11"	34'-4"
		25	15	24'-9"	23'-3"	21'-6"	29'-7"	27'-10"	25'-9"	33'-7"	31'-8"	29'-4"	36'-11"	35'-1"	32'-6"
		30	10	24'-9"	23'-6"	21'-11"	29'-7"	28'-0"	26'-2"	33'-8"	31'-11"	29'-9"	37'-1"	35'-4"	33'-0"
		30	15	23'-9"	22'-5"	20'-10"	28'-5"	26'-9"	24'-10"	32'-4"	30'-6"	28'-3"	34'-10"	33'-10"	31'-4"
		40	10	22'-6"	21'-7"	20'-5"	26'-11"	25'-10"	24'-5"	30'-8"	29'-5"	27'-9"	33'-2"	32'-7"	30'-9"
		40	15	22'-2"	21'-0"	19'-7"	26'-6"	25'-1"	23'-5"	29'-3"	28'-7"	26'-7"	31'-7"	30'-11"	29'-6"
		50	10	20'-10"	20'-0"	19'-0"	24'-11"	23'-11"	22'-9"	28'-1"	27'-3"	25'-10"	30'-3"	29'-11"	28'-8"
50	15	20'-10"	19'-11"	18'-7"	24'-6"	23'-9"	22'-3"	26'-11"	26'-6"	25'-3"	29'-0"	28'-7"	27'-11"		
16" o.c.	Non-Snow 125%	20	10	24'-9"	23'-4"	21'-8"	29'-7"	27'-11"	25'-11"	33'-8"	31'-9"	29'-5"	37'-4"	35'-2"	32'-8"
		20	15	23'-5"	22'-0"	20'-4"	28'-0"	26'-4"	24'-3"	31'-10"	29'-11"	27'-7"	35'-4"	33'-2"	30'-7"
		20	20	22'-4"	20'-11"	19'-3"	26'-8"	25'-0"	23'-0"	30'-5"	28'-5"	26'-2"	33'-3"	31'-7"	29'-0"
	Snow 115%	25	10	23'-6"	22'-2"	20'-8"	28'-1"	26'-6"	24'-8"	31'-10"	30'-2"	28'-1"	34'-3"	33'-6"	31'-2"
		25	15	22'-5"	21'-1"	19'-6"	26'-9"	25'-2"	23'-4"	29'-8"	28'-8"	26'-7"	32'-0"	31'-1"	29'-5"
		30	10	22'-5"	21'-3"	19'-10"	26'-10"	25'-5"	23'-9"	29'-9"	28'-11"	27'-0"	32'-1"	31'-6"	29'-11"
		30	15	21'-6"	20'-4"	18'-10"	25'-6"	24'-3"	22'-6"	28'-0"	27'-4"	25'-8"	30'-2"	29'-5"	28'-5"
		40	10	20'-5"	19'-7"	18'-6"	24'-3"	23'-5"	22'-1"	26'-8"	26'-3"	25'-2"	28'-8"	28'-3"	27'-9"
		40	15	20'-1"	19'-0"	17'-9"	23'-1"	22'-7"	21'-2"	25'-4"	24'-10"	24'-1"	27'-3"	26'-9"	26'-1"
		50	10	18'-11"	18'-1"	17'-2"	22'-2"	21'-8"	20'-7"	24'-4"	24'-0"	23'-5"	26'-2"	25'-11"	25'-5"
50	15	18'-7"	18'-0"	16'-10"	21'-3"	20'-10"	20'-1"	23'-4"	22'-11"	22'-5"	25'-1"	24'-8"	23'-7"		
19.2" o.c.	Non-Snow 125%	20	10	23'-3"	21'-11"	20'-4"	27'-9"	26'-2"	24'-4"	31'-7"	29'-10"	27'-8"	35'-1"	33'-1"	30'-8"
		20	15	22'-0"	20'-8"	19'-1"	26'-4"	24'-8"	22'-10"	29'-11"	28'-1"	25'-11"	32'-6"	31'-2"	28'-9"
		20	20	21'-0"	19'-8"	18'-1"	25'-1"	23'-6"	21'-7"	28'-1"	26'-9"	24'-7"	30'-4"	29'-3"	27'-3"
	Snow 115%	25	10	22'-1"	20'-10"	19'-5"	26'-4"	24'-11"	23'-3"	29'-0"	28'-4"	26'-5"	31'-3"	30'-7"	29'-3"
		25	15	21'-0"	19'-10"	18'-4"	24'-8"	23'-8"	21'-11"	27'-1"	26'-4"	24'-11"	29'-2"	28'-5"	27'-5"
		30	10	21'-1"	19'-11"	18'-8"	24'-9"	23'-10"	22'-3"	27'-2"	26'-8"	25'-4"	29'-3"	28'-9"	28'-0"
		30	15	20'-2"	19'-1"	17'-8"	23'-3"	22'-8"	21'-2"	25'-6"	24'-11"	24'-1"	27'-6"	26'-10"	26'-0"
		40	10	19'-2"	18'-5"	17'-4"	22'-1"	21'-10"	20'-9"	24'-3"	23'-11"	23'-5"	26'-2"	25'-9"	25'-3"
		40	15	18'-5"	17'-10"	16'-8"	21'-0"	20'-7"	19'-11"	23'-1"	22'-8"	22'-0"	24'-11"	24'-2"	22'-11"
		50	10	17'-8"	17'-0"	16'-2"	20'-2"	19'-11"	19'-4"	22'-2"	21'-11"	21'-6"	23'-2"	22'-7"	21'-10"
50	15	17'-0"	16'-8"	15'-9"	19'-4"	19'-0"	18'-7"	21'-0"	20'-3"	19'-4"	21'-3"	20'-7"	19'-8"		
24" o.c.	Non-Snow 125%	20	10	21'-6"	20'-4"	18'-10"	25'-9"	24'-3"	22'-6"	29'-2"	27'-7"	25'-8"	31'-5"	30'-8"	28'-5"
		20	15	20'-4"	19'-1"	17'-8"	24'-4"	22'-10"	21'-1"	26'-11"	26'-0"	24'-0"	29'-0"	28'-2"	26'-8"
		20	20	19'-5"	18'-2"	16'-9"	22'-11"	21'-9"	20'-0"	25'-2"	24'-3"	22'-9"	27'-1"	26'-2"	24'-11"
	Snow 115%	25	10	20'-5"	19'-4"	18'-0"	23'-7"	23'-1"	21'-6"	25'-11"	25'-5"	24'-6"	27'-11"	27'-4"	26'-7"
		25	15	19'-4"	18'-4"	17'-0"	22'-0"	21'-5"	20'-4"	24'-2"	23'-6"	22'-8"	26'-1"	25'-4"	24'-3"
		30	10	19'-4"	18'-6"	17'-3"	22'-1"	21'-8"	20'-8"	24'-3"	23'-10"	23'-3"	26'-2"	25'-8"	25'-0"
		30	15	18'-2"	17'-8"	16'-5"	20'-9"	20'-3"	19'-7"	22'-10"	22'-3"	21'-7"	24'-6"	23'-4"	21'-11"
		40	10	17'-4"	17'-0"	16'-1"	19'-9"	19'-6"	19'-1"	21'-8"	21'-3"	20'-5"	22'-2"	21'-6"	20'-8"
		40	15	16'-6"	16'-2"	15'-5"	18'-9"	18'-5"	17'-8"	19'-9"	19'-0"	18'-0"	20'-1"	19'-3"	18'-3"
		50	10	15'-10"	15'-7"	14'-11"	17'-11"	17'-6"	16'-11"	18'-2"	17'-9"	17'-2"	18'-6"	18'-0"	17'-5"
50	15	15'-2"	14'-11"	14'-7"	16'-5"	15'-11"	15'-2"	16'-9"	16'-2"	15'-5"	17'-0"	16'-5"	15'-8"		

NOTES

- ▶ Table values
 - are limited by shear, moment, total load deflection equal to L/180 and live load deflection equal to L/240. Check the local building code for other deflection limits that may apply.
 - represent the most restrictive of simple or multiple span applications. Analyze multiple span joists with the BC Calc® software if the length of any span is less than half the length of an adjacent span.
 - assume minimum bearing lengths without web stiffeners for joist depths of 16" and less.
- ▶ This table was designed to apply to a broad range of applications. It may be possible to exceed the limitations of this table by analyzing a specific application with the BC Calc® software.
- ▶ Slope roof joists at least ¼:12 to minimize ponding.
- ▶ Allowable spans and loads shall be adjusted and checked for wind load as required by local building code.

Roof Span Tables

Maximum clear span in feet and inches, based on horizontal spans.

115% and 125% Load Duration															
Condition			AJS® 190 – 2½" Flange Width												
			9½"			11½"			14"			16"			
O.C. Spacing and Load Duration	Live Load (psf)	Dead Load (psf)	4:12 or Less	4:12 to 8:12	8:12 to 12:12	4:12 or Less	4:12 to 8:12	8:12 to 12:12	4:12 or Less	4:12 to 8:12	8:12 to 12:12	4:12 or Less	4:12 to 8:12	8:12 to 12:12	
12" o.c.	Non-Snow 125%	20	10	27'-9"	26'-2"	24'-3"	33'-2"	31'-3"	29'-0"	37'-9"	35'-7"	33'-0"	41'-10"	39'-6"	36'-7"
		20	15	26'-3"	24'-8"	22'-9"	31'-5"	29'-6"	27'-3"	35'-9"	33'-7"	31'-0"	39'-8"	37'-3"	34'-4"
		20	20	25'-1"	23'-6"	21'-7"	30'-0"	28'-1"	25'-9"	34'-1"	31'-11"	29'-4"	37'-10"	35'-5"	32'-7"
	Snow 115%	25	10	26'-4"	24'-11"	23'-2"	31'-6"	29'-9"	27'-8"	35'-10"	33'-10"	31'-6"	39'-9"	37'-7"	34'-11"
		25	15	25'-2"	23'-8"	21'-11"	30'-0"	28'-3"	26'-2"	34'-2"	32'-2"	29'-9"	37'-11"	35'-8"	33'-0"
		30	10	25'-2"	23'-10"	22'-3"	30'-1"	28'-6"	26'-7"	34'-3"	32'-5"	30'-3"	38'-0"	36'-0"	33'-7"
		30	15	24'-2"	22'-9"	21'-2"	28'-10"	27'-3"	25'-3"	32'-10"	31'-0"	28'-9"	36'-5"	34'-4"	31'-11"
		40	10	22'-11"	22'-0"	20'-9"	27'-5"	26'-3"	24'-10"	31'-2"	29'-11"	28'-3"	34'-7"	33'-2"	31'-4"
		40	15	22'-7"	21'-4"	19'-11"	27'-0"	25'-6"	23'-9"	30'-8"	29'-1"	27'-1"	33'-10"	32'-3"	30'-0"
		50	10	21'-3"	20'-4"	19'-4"	25'-4"	24'-4"	23'-1"	28'-11"	27'-8"	26'-3"	32'-0"	30'-9"	29'-2"
50	15	21'-3"	20'-3"	18'-11"	25'-4"	24'-2"	22'-7"	28'-10"	27'-6"	25'-8"	31'-1"	30'-6"	28'-6"		
16" o.c.	Non-Snow 125%	20	10	25'-2"	23'-9"	22'-0"	30'-1"	28'-4"	26'-4"	34'-2"	32'-3"	29'-11"	37'-11"	35'-9"	33'-2"
		20	15	23'-10"	22'-4"	20'-8"	28'-6"	26'-9"	24'-8"	32'-5"	30'-5"	28'-1"	35'-11"	33'-9"	31'-2"
		20	20	22'-9"	21'-3"	19'-7"	27'-2"	25'-5"	23'-4"	30'-11"	28'-11"	26'-7"	34'-3"	32'-1"	29'-6"
	Snow 115%	25	10	23'-10"	22'-7"	21'-0"	28'-6"	27'-0"	25'-1"	32'-6"	30'-8"	28'-7"	36'-0"	34'-1"	31'-8"
		25	15	22'-9"	21'-5"	19'-10"	27'-2"	25'-7"	23'-9"	31'-0"	29'-2"	27'-0"	34'-3"	32'-4"	29'-11"
		30	10	22'-10"	21'-7"	20'-2"	27'-3"	25'-10"	24'-1"	31'-0"	29'-5"	27'-5"	34'-4"	32'-7"	30'-5"
		30	15	21'-10"	20'-8"	19'-2"	26'-2"	24'-8"	22'-11"	29'-9"	28'-1"	26'-1"	32'-4"	31'-2"	28'-11"
		40	10	20'-9"	19'-11"	18'-10"	24'-10"	23'-10"	22'-6"	28'-3"	27'-1"	25'-7"	30'-9"	30'-1"	28'-5"
		40	15	20'-5"	19'-4"	18'-0"	24'-5"	23'-1"	21'-7"	27'-2"	26'-4"	24'-6"	29'-3"	28'-8"	27'-2"
		50	10	19'-2"	18'-5"	17'-6"	22'-11"	22'-0"	20'-11"	26'-1"	25'-1"	23'-10"	27'-10"	27'-2"	26'-3"
50	15	19'-2"	18'-4"	17'-1"	22'-9"	21'-11"	20'-5"	25'-0"	24'-5"	23'-3"	25'-7"	24'-9"	23'-7"		
19.2" o.c.	Non-Snow 125%	20	10	23'-7"	22'-3"	20'-8"	28'-3"	26'-8"	24'-9"	32'-2"	30'-4"	28'-2"	35'-8"	33'-7"	31'-3"
		20	15	22'-4"	21'-0"	19'-5"	26'-9"	25'-1"	23'-2"	30'-5"	28'-7"	26'-5"	33'-9"	31'-8"	29'-3"
		20	20	21'-4"	20'-0"	18'-4"	25'-6"	23'-10"	21'-11"	29'-0"	27'-2"	25'-0"	32'-2"	30'-2"	27'-9"
	Snow 115%	25	10	22'-5"	21'-2"	19'-9"	26'-10"	25'-4"	23'-7"	30'-6"	28'-10"	26'-10"	33'-6"	32'-0"	29'-9"
		25	15	21'-4"	20'-2"	18'-8"	25'-7"	24'-1"	22'-3"	29'-0"	27'-5"	25'-4"	31'-3"	30'-5"	28'-2"
		30	10	21'-5"	20'-4"	18'-11"	25'-7"	24'-3"	22'-8"	29'-1"	27'-7"	25'-9"	31'-4"	30'-8"	28'-7"
		30	15	20'-6"	19'-5"	18'-0"	24'-7"	23'-2"	21'-6"	27'-4"	26'-4"	24'-6"	29'-6"	28'-9"	27'-2"
		40	10	19'-6"	18'-8"	17'-8"	23'-3"	22'-4"	21'-1"	26'-0"	25'-5"	24'-0"	27'-9"	27'-0"	25'-11"
		40	15	19'-2"	18'-2"	16'-11"	22'-6"	21'-8"	20'-3"	24'-9"	23'-10"	22'-7"	25'-2"	24'-2"	22'-11"
		50	10	18'-0"	17'-3"	16'-5"	21'-6"	20'-8"	19'-8"	22'-10"	22'-3"	21'-6"	23'-2"	23'-2"	22'-7"
50	15	18'-0"	17'-2"	16'-1"	20'-7"	19'-11"	19'-0"	21'-0"	20'-3"	19'-4"	21'-3"	20'-7"	19'-8"		
24" o.c.	Non-Snow 125%	20	10	21'-10"	20'-8"	19'-2"	26'-2"	24'-8"	22'-11"	29'-9"	28'-1"	26'-1"	33'-0"	31'-2"	28'-11"
		20	15	20'-8"	19'-5"	18'-0"	24'-9"	23'-3"	21'-6"	28'-2"	26'-6"	24'-5"	31'-1"	29'-4"	27'-1"
		20	20	19'-9"	18'-6"	17'-0"	23'-7"	22'-1"	20'-4"	26'-10"	25'-2"	23'-2"	29'-0"	27'-9"	25'-3"
	Snow 115%	25	10	20'-9"	19'-8"	18'-3"	24'-10"	23'-6"	21'-10"	27'-9"	26'-9"	24'-11"	29'-11"	29'-4"	27'-7"
		25	15	19'-9"	18'-8"	17'-3"	23'-7"	22'-3"	20'-8"	25'-11"	25'-3"	23'-6"	27'-6"	26'-1"	24'-3"
		30	10	19'-10"	18'-9"	17'-6"	23'-8"	22'-6"	21'-0"	26'-0"	25'-6"	23'-10"	27'-9"	26'-9"	25'-5"
		30	15	19'-0"	17'-11"	16'-8"	22'-3"	21'-5"	19'-11"	24'-2"	23'-0"	21'-7"	24'-6"	23'-4"	21'-11"
		40	10	18'-0"	17'-3"	16'-4"	21'-2"	20'-8"	19'-7"	21'-10"	21'-3"	20'-5"	22'-2"	21'-6"	20'-8"
		40	15	17'-8"	16'-9"	15'-8"	19'-5"	18'-8"	17'-8"	19'-9"	19'-0"	18'-0"	20'-1"	19'-3"	18'-3"
		50	10	16'-8"	16'-0"	15'-2"	17'-11"	17'-6"	16'-11"	18'-2"	17'-9"	17'-2"	18'-6"	18'-0"	17'-5"
50	15	16'-2"	15'-8"	14'-10"	16'-5"	15'-11"	15'-2"	16'-9"	16'-2"	15'-5"	17'-0"	16'-5"	15'-8"		

NOTES

► Table values

- are limited by shear, moment, total load deflection equal to L/180 and live load deflection equal to L/240. Check the local building code for other deflection limits that may apply.
- represent the most restrictive of simple or multiple span applications. Analyze multiple span joists with the BC Calc® software if the length of any span is less than half the length of an adjacent span.
- assume minimum bearing lengths without web stiffeners for joist depths of 16" and less.

► All 18" and 20" AJS® joists require web stiffeners.

- This table was designed to apply to a broad range of applications. It may be possible to exceed the limitations of this table by analyzing a specific application with the BC Calc® software.
- Slope roof joists at least ¼:12 to minimize ponding.
- Allowable spans and loads shall be adjusted and checked for wind load as required by local building code.

Roof Span Tables

Maximum clear span in feet and inches, based on horizontal spans.

115% and 125% Load Duration

Condition			AJS® 25 (3/8" Web Thickness) — 3 1/2" Flange Width												
			9 1/2"			11 7/8"			14"			16"			
O.C. Spacing and Load Duration	Live Load (psf)	Dead Load (psf)	4:12 or Less	4:12 to 8:12	8:12 to 12:12	4:12 or Less	4:12 to 8:12	8:12 to 12:12	4:12 or Less	4:12 to 8:12	8:12 to 12:12	4:12 or Less	4:12 to 8:12	8:12 to 12:12	
12" o.c.	Non-Snow 125%	20	10	30'-5"	28'-9"	26'-8"	36'-4"	34'-3"	31'-10"	41'-4"	38'-11"	36'-2"	45'-9"	43'-2"	40'-1"
		20	15	28'-10"	27'-1"	25'-0"	34'-5"	32'-4"	29'-10"	39'-1"	36'-9"	33'-11"	43'-4"	40'-8"	37'-7"
		20	20	27'-6"	25'-9"	23'-8"	32'-10"	30'-9"	28'-3"	37'-4"	34'-11"	32'-2"	41'-4"	38'-9"	35'-7"
	Snow 115%	25	10	28'-11"	27'-4"	25'-5"	34'-6"	32'-7"	30'-4"	39'-3"	37'-1"	34'-6"	43'-5"	41'-1"	38'-3"
		25	15	27'-7"	25'-11"	24'-0"	32'-11"	31'-0"	28'-8"	37'-5"	35'-3"	32'-7"	41'-5"	39'-0"	36'-2"
		30	10	27'-8"	26'-2"	24'-5"	33'-0"	31'-3"	29'-2"	37'-6"	35'-6"	33'-2"	41'-6"	39'-4"	36'-8"
		30	15	26'-6"	25'-0"	23'-2"	31'-8"	29'-10"	27'-8"	35'-11"	33'-11"	31'-6"	39'-10"	37'-7"	34'-11"
		40	10	25'-2"	24'-1"	22'-9"	30'-0"	28'-9"	27'-2"	34'-1"	32'-9"	30'-11"	37'-10"	36'-3"	34'-3"
		40	15	24'-9"	23'-5"	21'-10"	29'-7"	28'-0"	26'-1"	33'-7"	31'-10"	29'-8"	37'-3"	35'-3"	32'-10"
		50	10	23'-3"	22'-4"	21'-2"	27'-9"	26'-8"	25'-4"	31'-7"	30'-4"	28'-9"	35'-0"	33'-7"	31'-11"
50	15	23'-3"	22'-2"	20'-9"	27'-9"	26'-6"	24'-9"	31'-7"	30'-1"	28'-2"	35'-0"	33'-4"	31'-2"		
16" o.c.	Non-Snow 125%	20	10	27'-7"	26'-0"	24'-2"	32'-11"	31'-1"	28'-10"	37'-5"	35'-4"	32'-9"	41'-6"	39'-2"	36'-4"
		20	15	26'-1"	24'-6"	22'-8"	31'-2"	29'-3"	27'-1"	35'-5"	33'-4"	30'-9"	39'-3"	36'-11"	34'-1"
		20	20	24'-11"	23'-4"	21'-5"	29'-9"	27'-10"	25'-7"	33'-10"	31'-8"	29'-1"	37'-6"	35'-1"	32'-3"
	Snow 115%	25	10	26'-2"	24'-9"	23'-1"	31'-3"	29'-7"	27'-6"	35'-6"	33'-7"	31'-3"	39'-5"	37'-3"	34'-8"
		25	15	25'-0"	23'-6"	21'-9"	29'-10"	28'-1"	26'-0"	33'-11"	31'-11"	29'-7"	37'-7"	35'-4"	32'-9"
		30	10	25'-0"	23'-8"	22'-1"	29'-10"	28'-4"	26'-5"	34'-0"	32'-2"	30'-0"	37'-8"	35'-8"	33'-3"
		30	15	24'-0"	22'-8"	21'-0"	28'-8"	27'-0"	25'-1"	32'-7"	30'-9"	28'-6"	36'-1"	34'-1"	31'-7"
		40	10	22'-9"	21'-10"	20'-7"	27'-2"	26'-1"	24'-8"	30'-11"	29'-8"	28'-0"	34'-3"	32'-10"	31'-0"
		40	15	22'-5"	21'-2"	19'-9"	26'-9"	25'-4"	23'-7"	30'-5"	28'-10"	26'-10"	33'-8"	31'-11"	29'-9"
		50	10	21'-0"	20'-2"	19'-2"	25'-2"	24'-2"	22'-11"	28'-7"	27'-5"	26'-1"	31'-8"	30'-5"	28'-11"
50	15	21'-0"	20'-1"	18'-9"	25'-2"	24'-0"	22'-5"	28'-7"	27'-3"	25'-6"	29'-7"	28'-8"	27'-4"		
19.2" o.c.	Non-Snow 125%	20	10	25'-11"	24'-5"	22'-8"	30'-11"	29'-2"	27'-1"	35'-2"	33'-2"	30'-10"	39'-0"	36'-9"	34'-2"
		20	15	24'-6"	23'-0"	21'-3"	29'-3"	27'-6"	25'-5"	33'-3"	31'-3"	28'-11"	36'-11"	34'-8"	32'-0"
		20	20	23'-5"	21'-11"	20'-2"	27'-11"	26'-2"	24'-1"	31'-9"	29'-9"	27'-4"	35'-2"	32'-11"	30'-4"
	Snow 115%	25	10	24'-7"	23'-3"	21'-8"	29'-4"	27'-9"	25'-10"	33'-5"	31'-7"	29'-5"	37'-0"	35'-0"	32'-7"
		25	15	23'-5"	22'-1"	20'-5"	28'-0"	26'-4"	24'-5"	31'-10"	30'-0"	27'-9"	35'-3"	33'-3"	30'-9"
		30	10	23'-6"	22'-3"	20'-9"	28'-1"	26'-7"	24'-10"	31'-11"	30'-3"	28'-3"	35'-4"	33'-6"	31'-3"
		30	15	22'-6"	21'-3"	19'-9"	26'-11"	25'-5"	23'-7"	30'-7"	28'-10"	26'-10"	33'-11"	32'-0"	29'-8"
		40	10	21'-4"	20'-6"	19'-4"	25'-6"	24'-6"	23'-2"	29'-0"	27'-10"	26'-4"	32'-2"	30'-10"	29'-2"
		40	15	21'-0"	19'-11"	18'-7"	25'-1"	23'-9"	22'-2"	28'-3"	27'-0"	25'-3"	29'-1"	28'-0"	26'-6"
		50	10	19'-9"	18'-11"	18'-0"	23'-7"	22'-8"	21'-6"	26'-1"	25'-5"	24'-6"	26'-10"	26'-2"	25'-3"
50	15	19'-9"	18'-10"	17'-7"	23'-3"	22'-6"	21'-0"	23'-11"	23'-2"	22'-1"	24'-8"	23'-10"	22'-9"		
24" o.c.	Non-Snow 125%	20	10	24'-0"	22'-8"	21'-0"	28'-8"	27'-0"	25'-1"	32'-7"	30'-9"	28'-6"	36'-1"	34'-1"	31'-7"
		20	15	22'-8"	21'-4"	19'-8"	27'-1"	25'-6"	23'-6"	30'-10"	29'-0"	26'-9"	34'-2"	32'-1"	29'-8"
		20	20	21'-8"	20'-3"	18'-8"	25'-10"	24'-3"	22'-3"	29'-5"	27'-6"	25'-4"	32'-7"	30'-6"	28'-1"
	Snow 115%	25	10	22'-9"	21'-6"	20'-1"	27'-2"	25'-9"	23'-11"	30'-11"	29'-3"	27'-3"	34'-3"	32'-5"	30'-2"
		25	15	21'-8"	20'-5"	18'-11"	25'-11"	24'-5"	22'-7"	29'-5"	27'-9"	25'-9"	31'-10"	30'-2"	28'-1"
		30	10	21'-9"	20'-7"	19'-3"	25'-11"	24'-7"	23'-0"	29'-6"	28'-0"	26'-2"	32'-1"	30'-11"	28'-11"
		30	15	20'-10"	19'-8"	18'-3"	24'-10"	23'-6"	21'-10"	27'-7"	26'-3"	24'-7"	28'-4"	27'-0"	25'-4"
		40	10	19'-9"	18'-11"	17'-11"	23'-7"	22'-8"	21'-5"	24'-11"	24'-3"	23'-3"	25'-8"	24'-11"	23'-11"
		40	15	19'-5"	18'-5"	17'-2"	21'-11"	21'-1"	19'-11"	22'-7"	21'-8"	20'-7"	23'-3"	22'-4"	21'-2"
		50	10	18'-3"	17'-6"	16'-8"	20'-2"	19'-8"	19'-0"	20'-9"	20'-3"	19'-7"	21'-5"	20'-11"	20'-2"
50	15	17'-11"	17'-4"	16'-3"	18'-7"	17'-11"	17'-1"	19'-1"	18'-6"	17'-8"	19'-8"	19'-0"	18'-2"		

NOTES

- ▶ Table values
 - are limited by shear, moment, total load deflection equal to L/180 and live load deflection equal to L/240. Check the local building code for other deflection limits that may apply.
 - represent the most restrictive of simple or multiple span applications. Analyze multiple span joists with the BC Calc® software if the length of any span is less than half the length of an adjacent span.
 - assume minimum bearing lengths without web stiffeners for joist depths of 16" and less.
- ▶ This table was designed to apply to a broad range of applications. It may be possible to exceed the limitations of this table by analyzing a specific application with the BC Calc® software.
- ▶ Slope roof joists at least 1/4:12 to minimize ponding.
- ▶ Allowable spans and loads shall be adjusted and checked for wind load as required by local building code.

Roof Load Tables

Allowable Uniform Roof Load in pounds per lineal foot (PLF)

115% and 125% Load Duration

Use of these tables should be limited to roof slopes of 3½:12 or less. For steeper slopes, see pages 16–20.

Span Length	AJS® 140 — 2½" Flange Width											
	9½"			11⅞"			14"			16"		
	Total Load		Deflection	Total Load		Deflection	Total Load		Deflection	Total Load		Deflection
	Snow (115%)	Non-Snow (125%)	L/240	Snow (115%)	Non-Snow (125%)	L/240	Snow (115%)	Non-Snow (125%)	L/240	Snow (115%)	Non-Snow (125%)	L/240
6	353	383	–	358	389	–	360	392	–	364	396	–
7	302	329	–	307	334	–	309	336	–	312	339	–
8	264	287	–	269	292	–	270	294	–	273	297	–
9	235	255	–	239	259	–	240	261	–	242	264	–
10	211	230	–	215	233	–	216	235	–	218	237	–
11	182	198	–	195	212	–	196	213	–	198	216	–
12	153	166	–	179	194	–	180	196	–	182	198	–
13	130	142	–	165	179	–	166	180	–	168	182	–
14	112	122	–	146	158	–	154	168	–	156	169	–
15	98	106	–	127	138	–	144	156	–	145	158	–
16	86	93	85	111	121	–	134	146	–	136	148	–
17	76	83	71	99	107	–	119	129	–	128	139	–
18	68	74	60	88	96	–	106	115	–	121	132	–
19	61	66	51	79	86	–	95	103	–	110	120	–
20	55	58	44	71	77	–	86	93	–	99	108	–
21	50	50	38	64	70	–	78	85	–	90	98	–
22	44	44	33	59	64	56	71	77	–	82	89	–
23				54	58	49	65	70	–	75	82	–
24				49	54	44	59	65	–	69	75	–
25				45	49	39	55	59	–	63	69	–
26				42	45	34	51	55	–	59	64	–
27							47	51	45	54	59	–
28							43	47	41	51	55	–
29							41	44	37	47	51	–
30										44	48	–
31										41	45	–
32												
33												
34												

NOTES

- ▶ Total Load values are limited by shear, moment, or deflection equal to L/180.
- ▶ Deflection values are limited by live load deflection equal to L/240. Check the local building code for other deflection limits that may apply.
- ▶ Both the Total Load and Deflection columns must be checked. Where a deflection value is not shown, the total load value will control.
- ▶ Table values assume minimum bearing lengths without web stiffeners for joist depths of 16" and less.
- ▶ Slope roof joists at least ¼:12 to minimize ponding.
- ▶ Table values apply to either simple or multiple span joists. Span is measured center-to-center of the minimum required bearing length. Analyze multiple span joists with the BC Calc® software if the length of any span is less than half the length of an adjacent span.
- ▶ This table was designed to apply to a broad range of applications. It may be possible to exceed the limitations of this table by analyzing a specific application with the BC Calc® software.
- ▶ Allowable spans and loads shall be adjusted and checked for wind load as required by local building code.

Roof Load Tables

Allowable Uniform Roof Load in pounds per lineal foot (PLF)

115% and 125% Load Duration

Use of these tables should be limited to roof slopes of 3½:12 or less. For steeper slopes, see pages 16–20.

Span Length	AJS® 150 — 2½" Flange Width											
	9½"			11⅞"			14"			16"		
	Total Load		Deflection	Total Load		Deflection	Total Load		Deflection	Total Load		Deflection
	Snow (115%)	Non-Snow (125%)	L/240	Snow (115%)	Non-Snow (125%)	L/240	Snow (115%)	Non-Snow (125%)	L/240	Snow (115%)	Non-Snow (125%)	L/240
6	353	383	–	358	389	–	360	392	–	364	396	–
7	302	329	–	307	334	–	309	336	–	312	339	–
8	264	287	–	269	292	–	270	294	–	273	297	–
9	235	255	–	239	259	–	240	261	–	242	264	–
10	211	230	–	215	233	–	216	235	–	218	237	–
11	192	209	–	195	212	–	196	213	–	198	216	–
12	176	191	–	179	194	–	180	196	–	182	198	–
13	150	163	–	165	179	–	166	180	–	168	182	–
14	129	141	–	153	167	–	154	168	–	156	169	–
15	113	122	109	143	155	–	144	156	–	145	158	–
16	99	107	90	128	139	–	135	147	–	136	148	–
17	87	95	76	113	123	–	127	138	–	128	139	–
18	78	84	64	101	110	–	120	130	–	121	132	–
19	70	72	55	91	99	–	109	119	–	115	125	–
20	62	62	47	82	89	79	98	107	–	109	118	–
21	53	53	41	74	81	69	89	97	–	104	113	–
22	47	47	36	67	73	60	81	88	–	94	103	–
23	41	41	31	62	67	53	74	81	–	86	94	–
24				57	61	47	68	74	–	79	86	–
25				52	54	41	63	68	60	73	79	–
26				48	48	37	58	63	54	67	73	–
27				43	43	33	54	59	48	62	68	–
28							50	54	43	58	63	–
29							47	51	39	54	59	53
30							43	46	35	50	55	48
31							41	42	32	47	51	43
32										44	48	40
33										42	45	36
34												

NOTES

- ▶ Total Load values are limited by shear, moment, or deflection equal to L/180.
- ▶ Deflection values are limited by live load deflection equal to L/240. Check the local building code for other deflection limits that may apply.
- ▶ Both the Total Load and Deflection columns must be checked. Where a deflection value is not shown, the total load value will control.
- ▶ Table values assume minimum bearing lengths without web stiffeners for joist depths of 16" and less.
- ▶ Slope roof joists at least ¼:12 to minimize ponding.

- ▶ Table values apply to either simple or multiple span joists. Span is measured center-to-center of the minimum required bearing length. Analyze multiple span joists with the BC Calc® software if the length of any span is less than half the length of an adjacent span.
- ▶ This table was designed to apply to a broad range of applications. It may be possible to exceed the limitations of this table by analyzing a specific application with the BC Calc® software.
- ▶ Allowable spans and loads shall be adjusted and checked for wind load as required by local building code.

Roof Load Tables

Allowable Uniform Roof Load in pounds per lineal foot (PLF)

115% and 125% Load Duration

Use of these tables should be limited to roof slopes of 3½:12 or less. For steeper slopes, see pages 16–20.

Span Length	AJS® 20 — 2½" Flange Width											
	9½"			11⅞"			14"			16"		
	Total Load		Deflection	Total Load		Deflection	Total Load		Deflection	Total Load		Deflection
	Snow (115%)	Non-Snow (125%)	L/240	Snow (115%)	Non-Snow (125%)	L/240	Snow (115%)	Non-Snow (125%)	L/240	Snow (115%)	Non-Snow (125%)	L/240
6	353	383	–	358	389	–	360	392	–	364	396	–
7	302	329	–	307	334	–	309	336	–	312	339	–
8	264	287	–	269	292	–	270	294	–	273	297	–
9	235	255	–	239	259	–	240	261	–	242	264	–
10	211	230	–	215	233	–	216	235	–	218	237	–
11	192	209	–	195	212	–	196	213	–	198	216	–
12	176	191	–	179	194	–	180	196	–	182	198	–
13	162	177	–	165	179	–	166	180	–	168	182	–
14	151	164	–	153	167	–	154	168	–	156	169	–
15	136	147	128	143	155	–	144	156	–	145	158	–
16	119	129	106	134	146	–	135	147	–	136	148	–
17	105	115	89	126	137	–	127	138	–	128	139	–
18	94	99	76	119	129	–	120	130	–	121	132	–
19	84	85	65	109	119	108	113	123	–	115	125	–
20	73	73	56	99	107	94	108	117	–	109	118	–
21	63	63	48	89	97	81	103	112	–	104	113	–
22	55	55	42	81	89	71	98	106	–	99	108	–
23	48	48	37	74	81	62	90	98	–	95	103	–
24	43	43	33	68	72	55	82	90	80	91	99	–
25				63	64	49	76	83	71	87	95	–
26				57	57	44	70	76	63	81	89	–
27				51	51	39	65	71	57	75	82	–
28				46	46	35	60	66	51	70	76	69
29				41	41	32	56	60	46	65	71	62
30							53	55	42	61	66	56
31							49	50	38	57	62	51
32							45	45	34	54	58	47
33							41	41	31	50	55	43
34										47	51	39
35										45	47	36
36										42	43	33
37										40	40	30
38												

NOTES

- ▶ Total Load values are limited by shear, moment, or deflection equal to L/180.
- ▶ Deflection values are limited by live load deflection equal to L/240. Check the local building code for other deflection limits that may apply.
- ▶ Both the Total Load and Deflection columns must be checked. Where a deflection value is not shown, the total load value will control.
- ▶ Table values assume minimum bearing lengths without web stiffeners for joist depths of 16" and less.
- ▶ Slope roof joists at least ¼:12 to minimize ponding.
- ▶ Table values apply to either simple or multiple span joists. Span is measured center-to-center of the minimum required bearing length. Analyze multiple span joists with the BC Calc® software if the length of any span is less than half the length of an adjacent span.
- ▶ This table was designed to apply to a broad range of applications. It may be possible to exceed the limitations of this table by analyzing a specific application with the BC Calc® software.
- ▶ Allowable spans and loads shall be adjusted and checked for wind load as required by local building code.

Roof Load Tables

Allowable Uniform Roof Load in pounds per lineal foot (PLF)

115% and 125% Load Duration

Use of these tables should be limited to roof slopes of 3½:12 or less. For steeper slopes, see pages 16–20.

Span Length	AJS® 190 — 2½" Flange Width											
	9½"			11⅞"			14"			16"		
	Total Load		Deflection	Total Load		Deflection	Total Load		Deflection	Total Load		Deflection
	Snow (115%)	Non-Snow (125%)	L/240	Snow (115%)	Non-Snow (125%)	L/240	Snow (115%)	Non-Snow (125%)	L/240	Snow (115%)	Non-Snow (125%)	L/240
6	353	383	–	358	389	–	360	392	–	364	396	–
7	302	329	–	307	334	–	309	336	–	312	339	–
8	264	287	–	269	292	–	270	294	–	273	297	–
9	235	255	–	239	259	–	240	261	–	242	264	–
10	211	230	–	215	233	–	216	235	–	218	237	–
11	192	209	–	195	212	–	196	213	–	198	216	–
12	176	191	–	179	194	–	180	196	–	182	198	–
13	162	177	–	165	179	–	166	180	–	168	182	–
14	151	164	–	153	167	–	154	168	–	156	169	–
15	141	153	134	143	155	–	144	156	–	145	158	–
16	132	143	111	134	146	–	135	147	–	136	148	–
17	121	123	94	126	137	–	127	138	–	128	139	–
18	104	104	79	119	129	–	120	130	–	121	132	–
19	89	89	68	113	123	108	113	123	–	115	125	–
20	77	77	59	107	116	98	108	117	–	109	118	–
21	67	67	51	102	111	85	103	112	–	104	113	–
22	58	58	44	93	97	74	98	106	–	99	108	–
23	51	51	39	85	86	65	94	102	–	95	103	–
24	45	45	34	76	76	58	90	98	84	91	99	–
25	40	40	30	67	67	51	86	94	75	87	95	–
26				60	60	46	80	87	67	84	91	–
27				54	54	41	75	78	60	80	88	–
28				48	48	37	69	70	54	78	84	72
29				43	43	33	63	63	48	75	81	65
30							57	57	44	70	76	59
31							52	52	40	66	70	54
32							47	47	36	61	64	49
33							43	43	33	58	59	45
34							40	40	30	54	54	41
35										49	49	38
36										45	45	35
37										42	42	32
38												

NOTES

- ▶ Total Load values are limited by shear, moment, or deflection equal to L/180.
- ▶ Deflection values are limited by live load deflection equal to L/240. Check the local building code for other deflection limits that may apply.
- ▶ Both the Total Load and Deflection columns must be checked. Where a deflection value is not shown, the total load value will control.
- ▶ Table values assume minimum bearing lengths without web stiffeners for joist depths of 16" and less.
- ▶ Slope roof joists at least ¼:12 to minimize ponding.
- ▶ Table values apply to either simple or multiple span joists. Span is measured center-to-center of the minimum required bearing length. Analyze multiple span joists with the BC Calc® software if the length of any span is less than half the length of an adjacent span.
- ▶ This table was designed to apply to a broad range of applications. It may be possible to exceed the limitations of this table by analyzing a specific application with the BC Calc® software.
- ▶ Allowable spans and loads shall be adjusted and checked for wind load as required by local building code.

Roof Load Tables

Allowable Uniform Roof Load in pounds per lineal foot (PLF)

115% and 125% Load Duration

Use of these tables should be limited to roof slopes of 3½:12 or less. For steeper slopes, see pages 16–20.

Span Length	AJS® 25 (3/8" Web Thickness) – 3 1/2" Flange Width											
	9 1/2"			11 7/8"			14"			16"		
	Total Load		Deflection	Total Load		Deflection	Total Load		Deflection	Total Load		Deflection
	Snow (115%)	Non-Snow (125%)	L/240	Snow (115%)	Non-Snow (125%)	L/240	Snow (115%)	Non-Snow (125%)	L/240	Snow (115%)	Non-Snow (125%)	L/240
6	356	387	–	358	389	–	360	392	–	364	396	–
7	305	332	–	307	334	–	309	336	–	312	339	–
8	267	290	–	269	292	–	270	294	–	273	297	–
9	237	258	–	239	259	–	240	261	–	242	264	–
10	214	232	–	215	233	–	216	235	–	218	237	–
11	194	211	–	195	212	–	196	213	–	198	216	–
12	178	193	–	179	194	–	180	196	–	182	198	–
13	164	179	–	165	179	–	166	180	–	168	182	–
14	152	166	–	153	167	–	154	168	–	156	169	–
15	142	155	–	143	155	–	144	156	–	145	158	–
16	133	145	–	134	146	–	135	147	–	136	148	–
17	125	136	121	126	137	–	127	138	–	128	139	–
18	118	129	103	119	129	–	120	130	–	121	132	–
19	112	116	88	113	123	–	113	123	–	115	125	–
20	100	100	76	107	116	–	108	117	–	109	118	–
21	87	87	66	102	111	–	103	112	–	104	113	–
22	76	76	58	93	102	–	98	106	–	99	108	–
23	67	67	51	85	93	–	94	102	–	95	103	–
24	59	59	45	78	85	75	90	98	–	91	99	–
25	52	52	40	72	79	67	86	94	–	87	95	–
26	46	46	35	67	73	59	80	87	–	84	91	–
27	42	42	32	62	67	53	75	81	–	80	88	–
28				58	63	48	69	75	–	78	84	–
29				54	57	43	65	70	63	75	81	–
30				50	51	39	60	66	57	70	76	–
31				47	47	35	56	61	52	66	71	–
32				42	42	32	53	58	47	61	67	–
33							50	54	43	58	63	–
34							47	51	39	54	59	53
35							44	47	36	51	56	49
36							42	44	33	48	53	45
37										46	50	41
38										43	47	38

NOTES

- ▶ Total Load values are limited by shear, moment, or deflection equal to L/180.
- ▶ Deflection values are limited by live load deflection equal to L/240. Check the local building code for other deflection limits that may apply.
- ▶ Both the Total Load and Deflection columns must be checked. Where a deflection value is not shown, the total load value will control.
- ▶ Table values assume minimum bearing lengths without web stiffeners for joist depths of 16" and less.
- ▶ Slope roof joists at least ¼:12 to minimize ponding.
- ▶ Table values apply to either simple or multiple span joists. Span is measured center-to-center of the minimum required bearing length. Analyze multiple span joists with the BC Calc® software if the length of any span is less than half the length of an adjacent span.
- ▶ This table was designed to apply to a broad range of applications. It may be possible to exceed the limitations of this table by analyzing a specific application with the BC Calc® software.
- ▶ Allowable spans and loads shall be adjusted and checked for wind load as required by local building code.

AJS Design Properties

AJS® Joist Series	Joist Depth	Weight (PLF)	Moment (ft-lbs)	EI x 10 ⁶ (lb-in ²)	K x 10 ⁶ (lbs)	Shear (lbs)	End Reaction (lbs)				Intermediate Reaction (lbs)			
							1½" Bearing		3½" Bearing		3½" Bearing		5¼" Bearing	
							No WS ⁽¹⁾	WS ⁽²⁾	No WS ⁽¹⁾	WS ⁽²⁾	No WS ⁽¹⁾	WS ⁽²⁾	No WS ⁽¹⁾	WS ⁽²⁾
140	9½	2.2	2,450	182	5.2	1,160	950	1,240	1,175	1,480	2,350	2,450	2,350	2,450
	11¾	2.5	3,175	310	6.6	1,490	955	1,335	1,215	1,595	2,390	2,800	2,390	2,800
	14	2.8	3,825	457	7.8	1,790	960	1,420	1,250	1,700	2,430	3,130	2,430	3,130
	16	3.1	4,435	623	9.0	2,065	970	1,500	1,285	1,800	2,465	3,435	2,465	3,435
150	9½	2.2	2,820	194	5.2	1,160	950	1,240	1,175	1,480	2,350	2,450	2,350	2,450
	11¾	2.5	3,650	331	6.6	1,490	955	1,335	1,215	1,595	2,390	2,800	2,390	2,800
	14	2.8	4,390	487	7.8	1,790	960	1,420	1,250	1,700	2,430	3,130	2,430	3,130
	16	3.1	5,090	664	9.0	2,065	970	1,500	1,285	1,800	2,465	3,435	2,465	3,435
20	9½	2.5	3,395	232	5.2	1,160	950	1,240	1,175	1,480	2,350	2,450	2,350	2,450
	11¾	2.8	4,400	394	6.6	1,490	955	1,335	1,215	1,595	2,390	2,800	2,390	2,800
	14	3.0	5,295	578	7.8	1,790	960	1,420	1,250	1,700	2,430	3,130	2,430	3,130
	16	3.3	6,140	786	9.0	2,065	970	1,500	1,285	1,800	2,465	3,435	2,465	3,435
190	9½	2.5	3,895	244	5.2	1,160	950	1,240	1,175	1,480	2,350	2,450	2,350	2,450
	11¾	2.8	5,045	414	6.6	1,490	955	1,335	1,215	1,595	2,390	2,800	2,390	2,800
	14	3.0	6,070	608	7.8	1,790	960	1,420	1,250	1,700	2,430	3,130	2,430	3,130
	16	3.3	7,040	827	9.0	2,065	970	1,500	1,285	1,800	2,465	3,435	2,465	3,435
25	9½	3.1	5,370	322	5.3	1,160	950	1,240	1,175	1,480	2,600	2,850	2,600	2,850
	11¾	3.4	6,960	545	6.7	1,490	955	1,335	1,215	1,595	2,690	3,190	2,690	3,190
	14	3.7	8,380	798	7.9	1,790	960	1,420	1,250	1,700	2,770	3,500	2,770	3,500
	16	3.9	9,720	1082	9.1	2,065	970	1,500	1,285	1,800	2,850	3,800	2,850	3,800

- (1) No web stiffeners required.
- (2) Web stiffeners required.
- (3) All 18" and 20" AJS® joists require web stiffeners.

NOTES

- ▶ Moment, shear and reaction values based upon a load duration of 100% and may be adjusted for other load durations.
- ▶ Design values listed are applicable for Allowable Stress Design (ASD).
- ▶ No additional repetitive member increase allowed.

$$\Delta = \frac{5wl^4}{384EI} + \frac{wl^2}{K}$$

Δ = deflection (in) EI = bending stiffness (lb-in²)
 w = uniform load (lb/in) K = shear deformation coefficient (lb)
 l = clear span (in)

Code Evaluation Report: ICC-ES®/APA® ESR-1144 (IBC®, IRC®)

Connection on Steel Beam	Connection with Hanger on Steel Beam	Hanger Connections to AJS® Headers
<p>F15D</p>	<p>F15E</p>	<p>F16D</p> <ul style="list-style-type: none"> ▶ Backer blocks shall be at least 12" long per hanger. ▶ Nails shall be clinched when possible. ▶ Verify capacity and fastening requirements of hangers and connectors. <div style="display: flex; justify-content: space-around;"> <div style="text-align: center;"> <p>"Top Mount" Backer block shall be tight to bottom of top flange with ¼" to 2" gap at top of bottom flange.</p> </div> <div style="text-align: center;"> <p>"Face Mount" Backer block shall be tight to bottom of top flange with ¼" to 2" gap at top of bottom flange.</p> </div> </div>

Rim Board Details and Properties

Rim Board Product Profiles

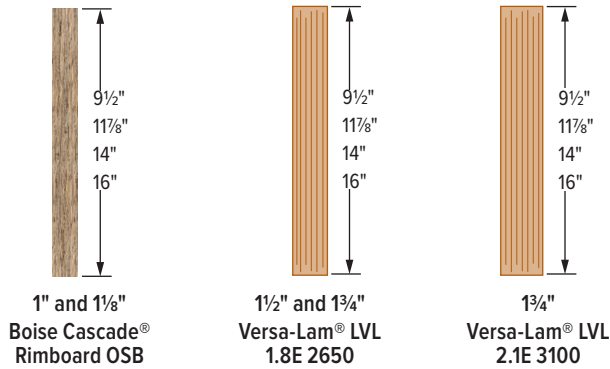

F07 Perpendicular

- ▶ Rim board: min. 8d nails at 6" o.c. per IRC. Connection per design professional of record's specification for shear transfer.
- ▶ See table for vertical load capacity.

F07A Parallel

- ▶ Rim board: min. 8d nails at 6" o.c. per IRC. Connection per design professional of record's specification for shear transfer.
- ▶ See table for vertical load capacity.

F56

AJS® joists perpendicular or parallel to rim

Exterior wall sheathing maximum thickness 1 5/8"

Rim board

Treated ledger; use only fasteners approved for use with treatment type.

Rim Board with Ledger Attachment

1/2" diameter through bolts (ASTM A307 Grades A & B, SAE J429 Grades 1 or 2, or higher with washer and nuts) or 1/2" diameter lag screws (full penetration), staggered.

Minimum connection for 40/10 psf deck loading:

Deck Joist Length	Connection
12'-0" and less	2 rows 1/2" bolts or lag screws, 24" o.c. (300 PLF max.)
12'-1" to 18'-0"	2 rows 1/2" bolts or lag screws, 16" o.c. (450 PLF max.)

For snow loads greater than 40 psf and/or dead loads greater than 10 psf, size connection per max. PLF values shown above.

NOTES

- ▶ Design of moisture control by others (only structural components shown).
- ▶ For information on deck lateral load connections per IRC section R507.2.3, contact Boise Cascade EWP Engineering.
- ▶ For use of proprietary screws to attach ledger, consult screw manufacturer literature.
- ▶ For further information on residential deck design, see AWC DCA 6 *Prescriptive Residential Wood Deck Construction Guide*.

Rim Board Properties

Product	Vertical Load Capacity		Maximum Floor Diaphragm Lateral Capacity (lb/ft)	Specific Gravity for Lateral Nail Design	Allowable Design Values			
	Uniform (PLF)	Point (lb)			Flexural Stress (lb/in ²)	Modulus of Elasticity—True (lb/in ²)	Horizontal Shear (lb/in ²)	Compression Perpendicular to Grain (lb/in ²)
1" Boise Cascade® Rimboard OSB (C2) ⁽¹⁾	3,300	3,500	180	0.5	Limited span capabilities, see Note 1			
1 1/8" Boise Cascade® Rimboard OSB (C1) ⁽¹⁾	4,850	3,500	180					
1 1/2" and 1 3/4" Versa-Lam® LVL 1.8E 2650 ⁽²⁾	4,250	3,700	Permitted per building code for all nominal 2" thick framing blocked and unblocked diaphragms (4" nail spacing and greater)		2,650	1,800,000	285	750
1 3/4" Versa-Lam® LVL 2.1E 3100 ⁽²⁾	5,700	4,300			3,100	2,100,000	285	750

(1) Rim board grades C1 and C2 per APA Form W345 U.S. Edition *APA Performance-Rated Rim Boards*.

(2) See ICC-ES/APA ESR-1040 for more information.

Closest Allowable Nail Spacing (Narrow Face)

Nail Size	Boise Cascade® Rimboard OSB ⁽¹⁾		Versa-Lam® LVL Rim Board ⁽²⁾	
	1"	1 1/8"	1 1/2"	1 3/4"
8d box (0.113"ø x 2.5")	3"	3"	3"	2"
8d common (0.131"ø x 2.5")	3"	3"	3"	3"
10d and 12d box (0.128"ø x 3", 3.25")	See publication listed in note (1) for additional nailing information.		3"	3"
16d box (0.135"ø x 3.5")			3"/5"	3"/5"
10d and 12d common and 16d sinker (0.148"ø x 3", 3.25")			4"/6"	4"/6"
16d common (0.162"ø x 3.5")			6"/8"	6"/8"

Red numbers indicate different nail spacing for Versa-Lam® LVL manufactured in Thorsby, AL.

(1) See *Performance Rated Rim Boards*, APA Form #W345 for more product information.

(2) See ICC-ES/APA ESR-1040 for more information.

Versa-Lam LVL Product Profiles

When you specify headers and beams made of Versa-Lam® laminated veneer lumber (LVL), you are building quality into your design. They are excellent for floor and roof framing supports and as headers for doors, windows, and garage doors. Versa-Lam® LVL can even be used in column applications. Because they have no camber, Versa-Lam® LVL products provide flatter, quieter floors—which helps ensure happier customers and significantly fewer builder call backs.

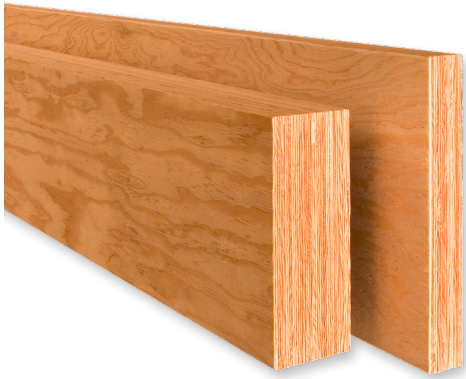

Versa-Lam® LVL products shall be installed in dry-use applications only, per their respective ICC-ES/APA ESR evaluation reports.

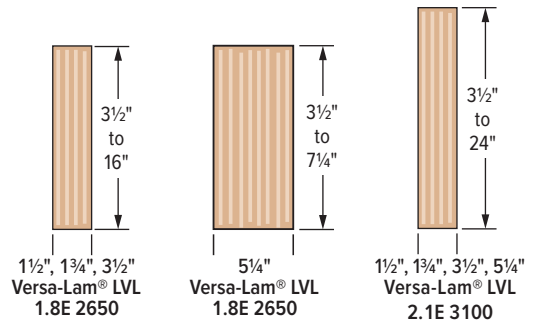

Some products may not be available in all markets. Contact your Boise Cascade EWP representative for availability.

Architectural Specifications

Scope — This work includes the complete furnishing and installation of all Versa-Lam® LVL beams as shown on the drawings, herein specified and necessary to complete the work.

Materials — Southern Pine or Douglas fir veneers, laminated in a press with all grain parallel with the length of the member. Glues used in lamination are phenol formaldehyde and isocyanate exterior-type adhesives which comply with ASTM D2559.

Design — Versa-Lam® LVL beams shall be sized and detailed to fit the dimensions and loads indicated on the plans. All designs shall be in accordance with allowable values developed in accordance with ASTM D5456 and listed in

the governing code evaluation service's report and section properties based upon standard engineering principles. Verification of design of the Versa-Lam® LVL beams by complete calculations shall be available upon request.

Drawings — Additional drawings showing layout and detail necessary for determining fit and placement in the buildings are (are not) to be provided by the supplier.

Fabrication — Versa-Lam® LVL beams shall be manufactured in a plant evaluated for fabrication by the governing code evaluation service and under the supervision of a third-party inspection agency listed by the corresponding evaluation service.

Storage and Installation — Versa-Lam® LVL beams, if stored prior to erection, shall be stored on stickers spaced a maximum of 15 ft. apart. Beams shall be stored on a dry, level surface and protected from the weather. They shall be handled with care so they are not damaged.

Versa-Lam® LVL beams are to be installed in accordance with the plans and Boise Cascade EWP's Installation Guide. Temporary construction loads which cause stresses beyond design limits are not permitted. Erection bracing shall be provided to assure adequate lateral support for the individual beams and the entire system until the sheathing material has been applied.

Codes — Versa-Lam® LVL beams shall be evaluated by a model code evaluation service.

Versa-Lam LVL Beam Details

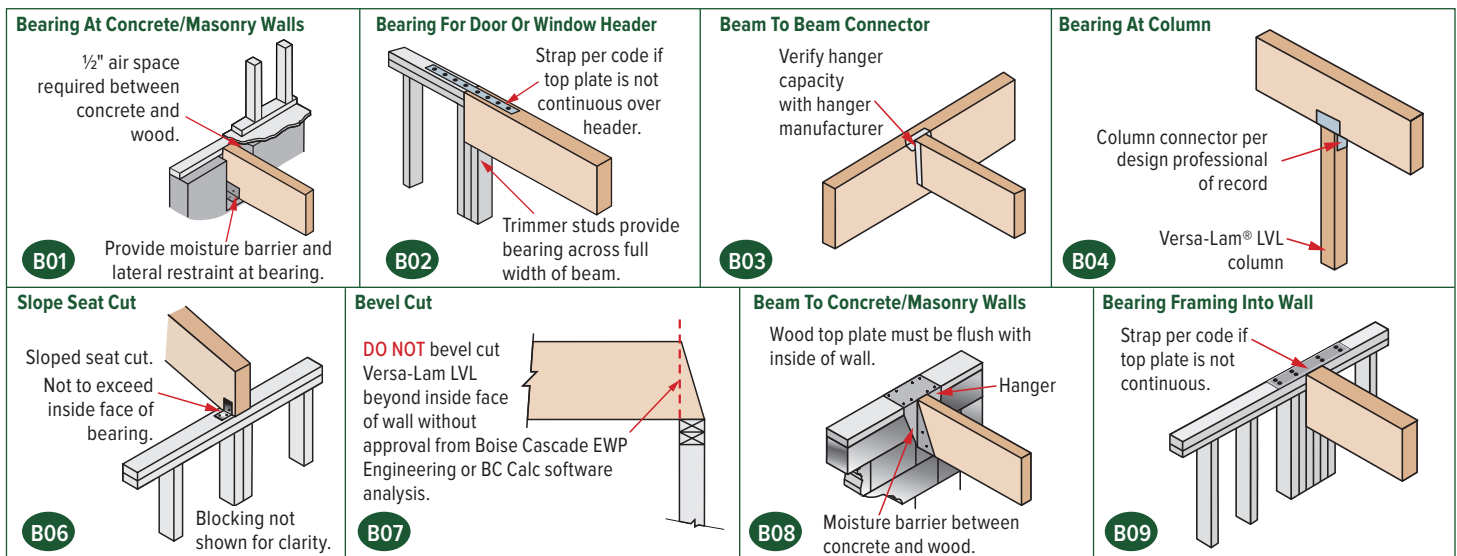

NOTES

- ▶ Minimum of 1/2" air space between beam and wall pocket or adequate barrier must be provided between beam and concrete/masonry.
- ▶ Adequate bearing shall be provided. If not shown on plans, please refer to load tables on pages 30–32.
- ▶ Versa-Lam® LVL beams are intended for interior applications only and should be kept as dry as possible during construction.
- ▶ Continuous lateral support of top of beam shall be provided (side or top bearing framing).

Versa-Lam LVL Allowable Holes

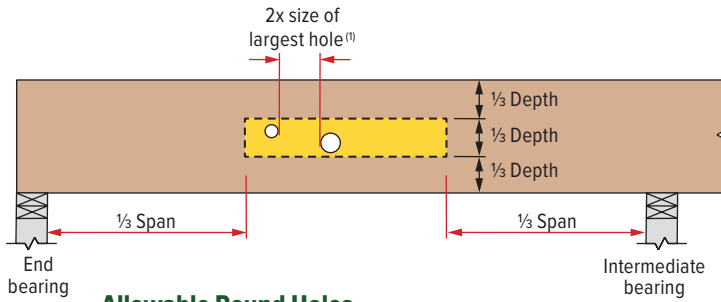

Allowable Round Holes

Table valid only for beams supporting uniform load.

Beam Depth	Max. Hole Diameter
5 1/2" to less than 7 1/4"	3/4"
7 1/4" to less than 9 1/4"	1"
9 1/4" to less than 18"	2"
18" to less than 24"	3"
24"	4"

NOTES

- The horizontal distance between adjacent holes must be at least two times the diameter of the larger hole. This restriction also applies to the location of holes relative to bolt holes in multiple ply beams. Holes shall not be stacked vertically.
 - Round holes may be drilled or cut with a hole saw anywhere within the shaded area of the beam.
 - Square and rectangular holes are not permitted.
 - Do not drill more than three access holes in any four foot long section of beam.
 - These limitations apply to holes drilled for plumbing or wiring access only. The size and location of holes drilled for fasteners are governed by the provisions of the *National Design Specification® for Wood Construction*.
 - Beams deflect under load. Size holes to provide clearance where required.
 - Allowable Round Holes table at left is valid for beams supporting uniform load only. For beams supporting concentrated loads or beams with larger holes, use BC Calc® software or contact Boise Cascade EWP Engineering.

Multiple Member Connections

Side-Loaded Applications — Maximum uniform side load (PLF)

Number of Plies	Nailed ⁽³⁾		1/2" Dia. Through Bolt ⁽¹⁾			5/8" Dia. Through Bolt ⁽¹⁾		
	2 Rows 16d Sinkers @ 12" o.c. ⁽⁵⁾	3 Rows 16d Sinkers @ 12" o.c.	2 Rows @ 24" o.c. Staggered	2 Rows @ 12" o.c. Staggered	2 Rows @ 6" o.c. Staggered	2 Rows @ 24" o.c. Staggered	2 Rows @ 12" o.c. Staggered	2 Rows @ 6" o.c. Staggered
1 3/4" Versa-Lam® LVL (Depths of 18" and less)								
2	470	705	505	1,010	2,020	560	1,120	2,245
3 ⁽²⁾	350	525	375	755	1,515	420	840	1,685
4 ⁽⁴⁾	Use bolt schedule		335	670	1,345	370	745	1,495
3 1/2" Versa-Lam® LVL								
2 ⁽⁴⁾	Use bolt schedule		855	1,715	N/A	1,125	2,250	N/A
Number of Plies	Nailed ⁽³⁾		1/2" Dia. Through Bolt ⁽¹⁾			5/8" Dia. Through Bolt ⁽¹⁾		
	3 Rows 16d Sinkers @ 12" o.c.	4 Rows 16d Sinkers @ 12" o.c.	3 Rows @ 24" o.c. 8" Staggered	3 Rows @ 18" o.c. 6" Staggered	3 Rows @ 12" o.c. 4" Staggered	3 Rows @ 24" o.c. 8" Staggered	3 Rows @ 18" o.c. 6" Staggered	3 Rows @ 12" o.c. 4" Staggered
1 3/4" Versa-Lam® LVL (Depths of 24" and less)								
2	705	940	755	1,010	1,515	840	1,120	1,685
3 ⁽²⁾	525	705	565	755	1,135	630	840	1,260
4 ⁽⁴⁾	Use bolt schedule		505	670	1,010	560	745	1,120

Top-Loaded Applications — For top-loaded beams and beams with side loads less than those shown in table above.

Plies	Depth	Number of Rows	Fastening ⁽³⁾	Maximum Uniform Load From One Side
Two 1 3/4" plies	11 7/8" & less	2	16d box/sinker nails @ 12" o.c.	400 PLF
	14" - 18"	3		600 PLF
	24"	4		800 PLF
Three 1 3/4" plies ⁽²⁾	11 7/8" & less	2		300 PLF
	14" - 18"	3		450 PLF
24"	4	600 PLF		
Four 1 3/4" plies	18" & less	2	1/2" bolts @ 24" o.c., staggered	335 PLF
	24"	3	1/2" bolts @ 24" o.c., staggered every 8"	505 PLF
Two 3 1/2" plies	18" & less	2	1/2" bolts @ 24" o.c., staggered	855 PLF
	20" - 24"	3	1/2" bolts @ 24" o.c., staggered every 8"	1,285 PLF

NOTES

- Design values apply to common bolts that conform to ANSI/ASME standard B18.21-1981 (ASTM A307 Grades A&B, SAE J429 Grades 1 or 2, or higher). A washer not less than a standard cut washer shall be between the wood and the bolt head and between the wood and the nut. The distance from the edge of the beam to the bolt holes must be at least 2" for 1/2" bolts and 2 1/2" for 5/8" bolts. Bolt holes shall be the same diameter as the bolt.
 - Beams wider than 7" must be designed by the engineer of record.
 - All values in these tables may be increased by 15% for snow-load roofs and by 25% for non-snow load roofs where the building code allows.
 - Use allowable load tables or BC Calc® software to size beams.
 - An equivalent specific gravity of 0.5 may be used when designing specific connections with Versa-Lam® LVL.
 - Connection values are based upon the NDS, 2018 Edition.
 - FastenMaster TrussLOK®, Simpson Strong-Tie SDW or SDS, and MiTek WS screws may also be used to connect multiple member Versa-Lam® LVL beams. Contact Boise Cascade EWP Engineering for more information.
- The nail schedules shown apply to both sides of a 3-ply beam.
- 16d box nails = 0.135" diameter x 3.5" length, 16d sinker nails = 0.148" diameter x 3.25" length.
- When side-loaded, 7" wide beams must be properly braced to prevent rotation.
- 14" and deeper 1 3/4" beams require minimum 3 rows of nails.

Designing Connections For Multiple-Ply Versa-Lam® LVL Beams

When using multiple ply Versa-Lam® LVL beams to create a wider member, the connection of the plies is as critical as determining the beam size. When side loaded beams are not connected properly, the inside plies do not support their share of the load and thus the load-carrying capacity of the full member decreases significantly.

The following example shows how to size and connect a multiple-ply Versa-Lam® LVL floor beam.

Given: Beam with a 16'-0" span (*shown above*) supports a residential floor load (40 psf live load, 10 psf dead load). Beam depth is limited to 14".

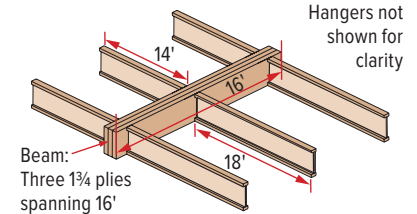

Find: A beam of multiple 1 3/4" plies of Versa-Lam® LVL that can support the design loads, plus the beam's proper connection schedule.

- Calculate tributary width and load the beam is supporting:

$$14/2 + 18/2 = 16 \text{ ft. tributary width}$$

$$\text{Live Load: } 40 \text{ psf} \times 16 \text{ ft.} = 640 \text{ PLF}$$

$$\text{Dead Load: } 10 \text{ psf} \times 16 \text{ ft.} = 160 \text{ PLF}$$

$$\text{Total Load: } 640 \text{ PLF} + 160 \text{ PLF} = 800 \text{ PLF}$$
- Use the PLF table in your region's specifier guide or BC Calc® software to size the beam..
 - A 3-ply Versa-Lam® LVL 1 3/4" x 14" beam will adequately support the calculated design load.
- Calculate the maximum PLF load from longest side (18' in this case).

$$\text{Max. Side Load} = (18/2) \times (40 + 10 \text{ psf}) = 450 \text{ PLF}$$
- See the Side-Loaded Applications table (at left) for 1 3/4" Versa-Lam® LVL, 3 plies.
- The proper connection schedule must have a capacity greater than the maximum side load:

Nailed: 3 rows 16d sinkers at 12" o.c.:
525 PLF is greater than 450 PLF **OK**

Bolts: 1/2" diameter 2 rows at 12" staggered:
755 PLF is greater than 450 PLF **OK**

Versa-Lam LVL Floor Load Table

Table Key: Top value = Allowable Total Load (PLF)
 Middle value = Allowable Live Load (PLF)
 Bottom value = Min. Required Bearing Length (inches) at End/Intermediate supports

Versa-Lam® LVL 2.1E 3100
 (100% Load Duration)

Beam Span (ft)	1 3/4"				3 1/2" or 2-Ply 1 3/4"						5 1/4" or 3-Ply 1 3/4"						7" 4-Ply 1 3/4" or 2-Ply 3 1/2"					
	Beam Depth				Beam Depth						Beam Depth						Beam Depth					
	7 1/4"	9 1/2"	11 7/8"	14"	7 1/4"	9 1/2"	11 7/8"	14"	16"	18"	9 1/2"	11 7/8"	14"	16"	18"	20"	11 7/8"	14"	16"	18"	20"	24"
6	763	1,063	1,424	1,795	1,525	2,126	2,849	3,590	4,387	4,794	3,189	4,273	5,384	6,580	7,191	7,188	5,697	7,179	8,773	9,588	9,584	9,576
	693	-	-	-	1,385	-	-	-	-	-	-	-	-	-	-	-	-	-	-	-	-	-
	1.8/4.4	2.4/6.1	3.3/8.2	4.1/10.3	1.8/4.4	2.4/6.1	3.3/8.2	4.1/10.3	5/12.6	5.5/13.8	2.4/6.1	3.3/8.2	4.1/10.3	5/12.6	5.5/13.8	5.5/13.8	3.3/8.2	4.1/10.3	5/12.6	5.5/13.8	5.5/13.8	5.5/13.8
7	636	877	1,160	1,444	1,271	1,753	2,321	2,888	3,482	4,107	2,630	3,481	4,331	5,223	6,160	6,157	4,641	5,775	6,964	8,213	8,209	8,201
	452	-	-	-	905	-	-	-	-	-	-	-	-	-	-	-	-	-	-	-	-	-
	1.7/4.3	2.4/5.9	3.1/7.8	3.9/9.7	1.7/4.3	2.4/5.9	3.1/7.8	3.9/9.7	4.7/11.7	5.5/13.8	2.4/5.9	3.1/7.8	3.9/9.7	4.7/11.7	5.5/13.8	5.5/13.8	3.1/7.8	3.9/9.7	4.7/11.7	5.5/13.8	5.5/13.8	5.5/13.8
8	462	746	979	1,207	924	1,492	1,957	2,414	2,886	3,402	2,237	2,936	3,622	4,328	5,103	5,384	3,914	4,829	5,771	6,803	7,178	7,170
	310	660	-	-	621	1,321	-	-	-	-	1,981	-	-	-	-	-	-	-	-	-	-	-
	1.5/3.5	2.3/5.7	3/7.5	3.7/9.3	1.5/3.5	2.3/5.7	3/7.5	3.7/9.3	4.4/11.1	5.2/13	2.3/5.7	3/7.5	3.7/9.3	4.4/11.1	5.2/13	5.5/13.8	3/7.5	3.7/9.3	4.4/11.1	5.2/13	5.5/13.8	5.5/13.8
9	329	649	846	1,037	658	1,297	1,692	2,074	2,463	2,884	1,946	2,537	3,111	3,694	4,325	4,782	3,383	4,148	4,926	5,767	6,376	6,368
	222	477	-	-	444	954	-	-	-	-	1,431	-	-	-	-	-	-	-	-	-	-	-
	1.5/3	2.2/5.6	2.9/7.3	3.6/8.9	1.5/3	2.2/5.6	2.9/7.3	3.6/8.9	4.3/10.6	5/12.4	2.2/5.6	2.9/7.3	3.6/8.9	4.3/10.6	5/12.4	5.5/13.8	2.9/7.3	3.6/8.9	4.3/10.6	5/12.4	5.5/13.8	5.5/13.8
10	242	527	745	909	484	1,055	1,489	1,817	2,148	2,502	1,582	2,234	2,726	3,222	3,753	4,301	2,978	3,635	4,296	5,003	5,734	5,726
	164	355	660	-	327	710	1,321	-	-	-	1,065	1,981	-	-	-	-	2,642	-	-	-	-	-
	1.5/3	2/5.1	2.9/7.1	3.5/8.7	1.5/3	2/5.1	2.9/7.1	3.5/8.7	4.1/10.3	4.8/12	2/5.1	2.9/7.1	3.5/8.7	4.1/10.3	4.8/12	5.5/13.8	2.9/7.1	3.5/8.7	4.1/10.3	4.8/12	5.5/13.8	5.5/13.8
11	183	401	665	808	365	803	1,330	1,617	1,904	2,209	1,204	1,995	2,425	2,856	3,313	3,800	2,659	3,233	3,807	4,417	5,067	5,201
	124	271	508	798	248	541	1,015	1,595	-	-	812	1,523	2,393	-	-	-	2,031	3,190	-	-	-	-
	1.5/3	1.7/4.3	2.8/7	3.4/8.5	1.5/3	1.7/4.3	2.8/7	3.4/8.5	4/10.1	4.7/11.7	1.7/4.3	2.8/7	3.4/8.5	4/10.1	4.7/11.7	5.4/13.4	2.8/7	3.4/8.5	4/10.1	4.7/11.7	5.4/13.4	5.5/13.8
12	141	312	585	728	282	623	1,170	1,456	1,709	1,977	935	1,755	2,184	2,564	2,965	3,390	2,340	2,912	3,418	3,953	4,519	4,764
	96	211	398	629	193	422	796	1,258	-	-	633	1,194	1,887	-	-	-	1,592	2,517	-	-	-	-
	1.5/3	1.5/3.6	2.7/6.8	3.4/8.4	1.5/3	1.5/3.6	2.7/6.8	3.4/8.4	3.9/9.9	4.6/11.4	1.5/3.6	2.7/6.8	3.4/8.4	3.9/9.9	4.6/11.4	5.2/13	2.7/6.8	3.4/8.4	3.9/9.9	4.6/11.4	5.2/13	5.5/13.8
13	111	246	470	662	221	493	941	1,324	1,550	1,789	739	1,411	1,986	2,326	2,683	3,059	1,881	2,647	3,101	3,577	4,078	4,394
	76	168	318	504	152	335	635	1,009	1,456	-	503	953	1,513	2,185	-	-	1,270	2,017	2,913	-	-	-
	1.5/3	1.5/3.1	2.4/5.9	3.3/8.3	1.5/3	1.5/3.1	2.4/5.9	3.3/8.3	3.9/9.7	4.5/11.2	1.5/3.1	2.4/5.9	3.3/8.3	3.9/9.7	4.5/11.2	5.1/12.7	2.4/5.9	3.3/8.3	3.9/9.7	4.5/11.2	5.1/12.7	5.5/13.8
14	88	198	380	585	176	396	759	1,171	1,418	1,633	594	1,139	1,756	2,128	2,449	2,786	1,519	2,342	2,837	3,265	3,715	4,076
	61	135	257	410	123	270	514	820	1,189	-	405	771	1,230	1,783	-	-	1,029	1,640	2,378	-	-	-
	1.5/3	1.5/3	2.1/5.1	3.2/7.9	1.5/3	1.5/3	2.1/5.1	3.2/7.9	3.8/9.6	4.4/11	1.5/3	2.1/5.1	3.2/7.9	3.8/9.6	4.4/11	5/12.5	2.1/5.1	3.2/7.9	3.8/9.6	4.4/11	5/12.5	5.5/13.8
15	71	161	310	499	143	322	621	998	1,307	1,502	483	931	1,497	1,960	2,253	2,558	1,242	1,997	2,614	3,003	3,410	3,801
	50	111	211	338	100	221	422	675	982	1,359	332	633	1,013	1,473	2,039	-	844	1,350	1,964	2,718	-	-
	1.5/3	1.5/3	1.8/4.5	2.9/7.2	1.5/3	1.5/3	1.8/4.5	2.9/7.2	3.8/9.5	4.3/10.9	1.5/3	1.8/4.5	2.9/7.2	3.8/9.5	4.3/10.9	4.9/12.3	1.8/4.5	2.9/7.2	3.8/9.5	4.3/10.9	4.9/12.3	5.5/13.8
16	58	132	257	414	117	265	514	829	1,151	1,390	397	770	1,243	1,727	2,085	2,364	1,027	1,658	2,303	2,780	3,151	3,561
	41	92	175	281	83	183	350	562	820	1,138	275	526	843	1,230	1,707	2,279	701	1,124	1,640	2,277	3,038	-
	1.5/3	1.5/3	1.6/4	2.6/6.4	1.5/3	1.5/3	1.6/4	2.6/6.4	3.6/8.9	4.3/10.7	1.5/3	1.6/4	2.6/6.4	3.6/8.9	4.3/10.7	4.9/12.2	1.6/4	2.6/6.4	3.6/8.9	4.3/10.7	4.9/12.2	5.5/13.8
17	110	214	347	96	220	429	695	1,018	1,274	1,374	330	643	1,042	1,527	1,911	2,196	858	1,389	2,036	2,547	2,929	3,348
	77	147	236	69	153	294	473	691	962	230	441	709	1,037	1,443	1,931	588	945	1,382	1,924	2,575	-	-
	1.5/3	1.5/3.6	2.3/5.7	1.5/3	1.5/3	1.5/3.6	2.3/5.7	3.3/8.4	4.2/10.5	1.5/3	1.5/3.6	2.3/5.7	3.3/8.4	4.2/10.5	4.8/12	1.5/3.6	2.3/5.7	3.3/8.4	4.2/10.5	4.8/12	5.5/13.8	5.5/13.8
18	92	181	294	80	185	361	587	865	1,134	277	542	881	1,298	1,701	2,051	723	1,175	1,731	2,268	2,735	3,160	-
	65	124	201	58	130	249	401	588	820	194	373	602	882	1,230	1,650	498	802	1,176	1,640	2,200	-	-
	1.5/3	1.5/3.2	2.1/5.2	1.5/3	1.5/3	1.5/3.2	2.1/5.2	3/7.6	4/9.9	1.5/3	1.5/3.2	2.1/5.2	3/7.6	4/9.9	4.8/11.9	1.5/3.2	2.1/5.2	3/7.6	4/9.9	4.8/11.9	5.5/13.8	5.5/13.8
19	78	153	250	67	156	307	500	739	1,016	234	460	751	1,109	1,524	1,863	614	1,001	1,479	2,032	2,484	2,991	-
	55	106	172	50	110	213	343	504	704	166	319	515	756	1,056	1,420	425	686	1,008	1,408	1,893	-	-
	1.5/3	1.5/3	1.9/4.7	1.5/3	1.5/3	1.5/3	1.9/4.7	2.7/6.8	3.7/9.4	1.5/3	1.5/3	1.9/4.7	2.7/6.8	3.7/9.4	4.6/11.4	1.5/3	1.9/4.7	2.7/6.8	3.7/9.4	4.6/11.4	5.5/13.8	5.5/13.8
20	66	131	215	57	133	263	429	636	895	199	394	644	954	1,343	1,678	525	859	1,272	1,790	2,237	2,839	-
	47	92	148	43	95	183	296	435	609	142	275	444	652	913	1,230	366	592	870	1,218	1,640	2,718	-
	1.5/3	1.5/3	1.7/4.2	1.5/3	1.5/3	1.7/4.2	2.5/6.2	3.5/8.7	1.5/3	1.5/3	1.7/4.2	2.5/6.2	3.5/8.7	4.3/10.8	1.5/3	1.7/4.2	2.5/6.2	3.5/8.7	4.3/10.8	5.5/13.8	5.5/13.8	5.5/13.8
22	98	161	-	-	98	196	322	479	678	147	293	483	719	1,016	1,379	391	644	959	1,355	1,839	2,576	-
	69	112	-	-	72	138	224	330	464	107	208	336	496	696	940	277	448	661	928	1,253	2,091	-
	1.5/3	1.5/3.5	-	-	1.5/3	1.5/3	1.5/3.5	2.1/5.2	2.9/7.3	1.5/3	1.5/3	1.5/3.5	2.1/5.2	2.9/7.3	3.9/9.8	1.5/3	1.5/3.5	2.1/5.2	2.9/7.3	3.9/9.8	5.5/13.8	5.5/13.8
24	74	123	-	-	73	149	246	369	523	110	223	370	553	785	1,070	297	493	738	1,047	1,426	2,184	-
	54	87	-	-	55	107	174	257	361	83	161	261	385	542	733	214	348	513	722	978	1,640	-
	1.5/3	1.5/3	-	-	1.5/3	1.5/3	1.5/3	1.8/4.4	2.5/6.2	1.5/3	1.5/3	1.5/3	1.8/4.4	2.5/6.2	3.4/8.4	1.5/3	1.5/3	1.8/4.4	2.5/6.2	3.4/8.4	5.1/12.8	5.5/13.8
26	57	96	-	-	56	115	192	289	411	84	172	288	433	617	844	230	384	577	823	1,125	1,853	-
	42	69	-	-	44	85	137	203	286	65	127	206	305	430	583	169	275	407	573	777	1,308	-
	1.5/3	1.5/3	-	-	1.5/3	1.5/3	1.5/3	1.5/3.8	2.1/5.3	1.5/3	1.5/3	1.5/3	1.5/3.8	2.1/5.3	2.9/7.2	1.5/3	1.5/3	1.5/3.8	2.1/5.3	2.9/7.2	4.7/11.8	5.5/13.8
28	-	76	-	-	90	151	229	328	464	64	135	227	344	492	675	180	303	458	656	900		

Versa-Lam LVL Snow Roof Load Table

Versa-Lam® LVL 2.1E 3100
Snow (115%) Load Duration

Table Key: Top value = Allowable Total Load (PLF)
Middle value = Allowable Live Load (PLF)
Bottom value = Min. Required Bearing Length (inches) at End/Intermediate supports

Beam Span (ft)	1¾"				3½" or 2-Ply 1¾"				5¼" or 3-Ply 1¾"				7" 4-Ply 1¾" or 2-Ply 3½"									
	Beam Depth				Beam Depth				Beam Depth				Beam Depth									
	7¼"	9½"	11½"	14"	7¼"	9½"	11½"	14"	16"	18"	9½"	11½"	14"	16"	18"	20"	11½"	14"	16"	18"	20"	24"
6	878	1,223	1,639	2,065	1,755	2,446	3,278	4,130	4,796	4,794	3,669	4,917	6,195	7,194	7,191	7,188	6,556	8,260	9,592	9,588	9,584	9,576
	–	–	–	–	–	–	–	–	–	–	–	–	–	–	–	–	–	–	–	–	–	–
	2/5	2.8/7	3.8/9.4	4.7/11.8	2/5	2.8/7	3.8/9.4	4.7/11.8	5.5/13.8	5.5/13.8	2.8/7	3.8/9.4	4.7/11.8	5.5/13.8	5.5/13.8	5.5/13.8	3.8/9.4	4.7/11.8	5.5/13.8	5.5/13.8	5.5/13.8	5.5/13.8
7	731	1,009	1,335	1,661	1,463	2,018	2,670	3,323	4,007	4,107	30,27	4,006	4,984	6,010	6,160	6,157	5,341	6,646	8,013	8,213	8,209	8,201
	678	–	–	–	1,357	–	–	–	–	–	–	–	–	–	–	–	–	–	–	–	–	–
	2/4.9	2.7/6.8	3.6/8.9	4.4/11.1	2/4.9	2.7/6.8	3.6/8.9	4.4/11.1	5.4/13.4	5.5/13.8	2.7/6.8	3.6/8.9	4.4/11.1	5.4/13.4	5.5/13.8	5.5/13.8	3.6/8.9	4.4/11.1	5.4/13.4	5.5/13.8	5.5/13.8	5.5/13.8
8	598	858	1,126	1,389	1,197	1,717	2,252	2,779	3,321	3,591	2,575	3,379	4,168	4,981	5,387	5,384	4,505	5,558	6,642	7,182	7,178	7,170
	466	–	–	–	931	–	–	–	–	–	–	–	–	–	–	–	–	–	–	–	–	–
	1.8/4.6	2.6/6.6	3.5/8.6	4.3/10.6	1.8/4.6	2.6/6.6	3.5/8.6	4.3/10.6	5.1/12.7	5.5/13.8	2.6/6.6	3.5/8.6	4.3/10.6	5.1/12.7	5.5/13.8	5.5/13.8	3.5/8.6	4.3/10.6	5.1/12.7	5.5/13.8	5.5/13.8	5.5/13.8
9	440	747	974	1,194	880	1,493	1,947	2,387	2,835	3,190	2,240	2,921	3,581	4,252	4,785	4,782	3,894	4,774	5,670	6,380	6,376	6,368
	333	715	–	–	665	1,431	–	–	–	–	2,146	–	–	–	–	–	–	–	–	–	–	–
	1.5/3.8	2.6/6.4	3.4/8.4	4.1/10.3	1.5/3.8	2.6/6.4	3.4/8.4	4.1/10.3	4.9/12.2	5.5/13.8	2.6/6.4	3.4/8.4	4.1/10.3	4.9/12.2	5.5/13.8	5.5/13.8	3.4/8.4	4.1/10.3	4.9/12.2	5.5/13.8	5.5/13.8	5.5/13.8
10	324	637	857	1,046	648	1,274	1,714	2,092	2,472	2,869	1,912	2,571	3,138	3,709	4,304	4,301	3,429	4,184	4,945	5,738	5,734	5,726
	246	532	–	–	491	1,065	–	–	–	–	1,597	–	–	–	–	–	–	–	–	–	–	–
	1.5/3.1	2.4/6.1	3.3/8.2	4/10	1.5/3.1	2.4/6.1	3.3/8.2	4/10	4.7/11.9	5.5/13.8	2.4/6.1	3.3/8.2	4/10	4.7/11.9	5.5/13.8	5.5/13.8	3.3/8.2	4/10	4.7/11.9	5.5/13.8	5.5/13.8	5.5/13.8
11	245	526	765	931	489	1,052	1,531	1,861	2,192	2,543	1,577	2,296	2,792	3,288	3,814	3,907	3,062	3,723	4,383	5,085	5,209	5,201
	186	406	762	–	372	812	1,523	–	–	–	1,218	2,285	–	–	–	–	3,046	–	–	–	–	–
	1.5/3	2.2/5.6	3.2/8.1	3.9/9.8	1.5/3	2.2/5.6	3.2/8.1	3.9/9.8	4.6/11.6	5.4/13.4	2.2/5.6	3.2/8.1	3.9/9.8	4.6/11.6	5.4/13.4	5.5/13.8	3.2/8.1	3.9/9.8	4.6/11.6	5.4/13.4	5.5/13.8	5.5/13.8
12	189	417	674	838	378	834	1,347	1,676	1,968	2,276	1,252	2,021	2,514	2,952	3,414	3,579	2,694	3,353	3,936	4,552	4,772	4,764
	144	317	597	–	289	633	1,194	–	–	–	950	1,791	–	–	–	–	2,389	–	–	–	–	–
	1.5/3	1.9/4.8	3.1/7.8	3.9/9.7	1.5/3	1.9/4.8	3.1/7.8	3.9/9.7	4.5/11.3	5.2/13.1	1.9/4.8	3.1/7.8	3.9/9.7	4.5/11.3	5.2/13.1	5.5/13.8	3.1/7.8	3.9/9.7	4.5/11.3	5.2/13.1	5.5/13.8	5.5/13.8
13	149	330	573	762	297	660	1,146	1,524	1,785	2,060	991	1,719	2,287	2,678	3,089	3,301	2,292	3,049	3,571	4,119	4,402	4,394
	114	251	476	756	229	503	953	1,513	–	–	754	1,429	2,269	–	–	–	1,905	3,026	–	–	–	–
	1.5/3	1.7/4.1	2.9/7.2	3.8/9.5	1.5/3	1.7/4.1	2.9/7.2	3.8/9.5	4.5/11.2	5.1/12.9	1.7/4.1	2.9/7.2	3.8/9.5	4.5/11.2	5.1/12.9	5.5/13.8	2.9/7.2	3.8/9.5	4.5/11.2	5.1/12.9	5.5/13.8	5.5/13.8
14	119	265	493	674	238	531	987	1,349	1,634	1,880	796	1,480	2,023	2,450	2,821	3,063	1,973	2,697	3,267	3,761	4,084	4,076
	92	203	386	615	184	405	771	1,230	–	–	608	1,157	1,845	–	–	–	1,543	2,460	–	–	–	–
	1.5/3	1.5/3.6	2.7/6.7	3.6/9.1	1.5/3	1.5/3.6	2.7/6.7	3.6/9.1	4.4/11	5.1/12.7	1.5/3.6	2.7/6.7	3.6/9.1	4.4/11	5.1/12.7	5.5/13.8	2.7/6.7	3.6/9.1	4.4/11	5.1/12.7	5.5/13.8	5.5/13.8
15	96	216	416	586	193	432	832	1,173	1,505	1,730	649	1,248	1,759	2,258	2,595	2,857	1,664	2,346	3,011	3,459	3,809	3,801
	75	166	317	506	150	332	633	1,013	1,473	–	497	950	1,519	2,210	–	–	1,266	2,025	2,946	–	–	–
	1.5/3	1.5/3.2	2.4/6	3.4/8.5	1.5/3	1.5/3.2	2.4/6	3.4/8.5	4.3/10.9	5/12.5	1.5/3.2	2.4/6	3.4/8.5	4.3/10.9	5/12.5	5.5/13.8	2.4/6	3.4/8.5	4.3/10.9	5/12.5	5.5/13.8	5.5/13.8
16	79	178	344	515	158	356	689	1,029	1,327	1,601	535	1,033	1,544	1,990	2,402	2,677	1,377	2,058	2,653	3,202	3,569	3,561
	62	137	263	421	124	275	526	843	1,230	–	412	788	1,264	1,845	–	–	1,051	1,686	2,460	–	–	–
	1.5/3	1.5/3	2.1/5.3	3.2/7.9	1.5/3	1.5/3	2.1/5.3	3.2/7.9	4.1/10.2	4.9/12.3	1.5/3	2.1/5.3	3.2/7.9	4.1/10.2	4.9/12.3	5.5/13.8	2.1/5.3	3.2/7.9	4.1/10.2	4.9/12.3	5.5/13.8	5.5/13.8
17	65	148	288	455	131	297	576	910	1,173	1,468	445	864	1,365	1,760	2,201	2,517	1,152	1,820	2,346	2,935	3,356	3,348
	52	115	220	354	104	230	441	709	1,037	1,443	345	661	1,063	1,555	2,165	–	882	1,418	2,074	2,886	–	–
	1.5/3	1.5/3	1.9/4.8	3/7.5	1.5/3	1.5/3	1.9/4.8	3/7.5	3.9/9.6	4.8/12	1.5/3	1.9/4.8	3/7.5	3.9/9.6	4.8/12	5.5/13.8	1.9/4.8	3/7.5	3.9/9.6	4.8/12	5.5/13.8	5.5/13.8
18	55	125	243	394	109	249	486	788	1,045	1,307	374	729	1,182	1,567	1,961	2,364	972	1,576	2,089	2,614	3,151	3,160
	44	97	187	301	87	194	373	602	882	1,230	291	560	902	1,322	1,845	–	747	1,203	1,763	2,460	–	–
	1.5/3	1.5/3	1.7/4.3	2.8/6.9	1.5/3	1.5/3	1.7/4.3	2.8/6.9	3.6/9.1	4.5/11.4	1.5/3	1.7/4.3	2.8/6.9	3.6/9.1	4.5/11.4	5.5/13.7	1.7/4.3	2.8/6.9	3.6/9.1	4.5/11.4	5.5/13.7	5.5/13.8
19	46	106	207	336	92	211	413	672	936	1,171	317	620	1,008	1,404	1,757	2,147	827	1,344	1,872	2,342	2,862	2,991
	37	83	160	257	74	166	319	515	756	1,056	249	479	772	1,133	1,584	2,130	638	1,029	1,511	2,112	2,839	–
	1.5/3	1.5/3	1.5/3.8	2.5/6.2	1.5/3	1.5/3	1.5/3.8	2.5/6.2	3.4/8.6	4.3/10.8	1.5/3	1.5/3.8	2.5/6.2	3.4/8.6	4.3/10.8	5.3/13.1	1.5/3.8	2.5/6.2	3.4/8.6	4.3/10.8	5.3/13.1	5.5/13.8
20	90	177	289	455	131	297	576	910	1,173	1,468	445	864	1,365	1,760	2,201	2,517	1,152	1,820	2,346	2,935	3,356	3,348
	71	137	222	354	104	230	441	709	1,037	1,443	345	661	1,063	1,555	2,165	–	882	1,418	2,074	2,886	–	–
	1.5/3	1.5/3.5	2.3/5.6	3.2/7.9	1.5/3	1.5/3.5	2.3/5.6	3.2/7.9	4.1/10.2	4.9/12.3	1.5/3	1.5/3.5	2.3/5.6	3.2/7.9	4.1/10.2	4.9/12.3	5.5/13.8	2.3/5.6	3.2/7.9	4.1/10.2	4.9/12.3	5.5/13.8
22	67	132	217	354	104	230	441	709	1,037	1,443	345	661	1,063	1,555	2,165	–	882	1,418	2,074	2,886	–	–
	54	104	168	257	74	166	319	515	756	1,056	249	479	772	1,133	1,584	2,130	638	1,029	1,511	2,112	2,839	–
	1.5/3	1.5/3	1.9/4.7	2.8/6.9	1.5/3	1.5/3	1.9/4.7	2.8/6.9	3.7/9.3	4.5/11.3	1.5/3	1.5/3	1.9/4.7	2.8/6.9	3.7/9.3	4.5/11.3	1.5/3	1.9/4.7	2.8/6.9	3.7/9.3	4.5/11.3	5.5/13.8

Versa-Lam LVL Non-Snow Roof Load Table

Table Key: Top value = Allowable Total Load (PLF)
 Middle value = Allowable Live Load (PLF)
 Bottom value = Min. Required Bearing Length (inches) at End/Intermediate supports

Versa-Lam® LVL 2.1E 3100
Non-Snow (125%) Load Duration

Beam Span (ft)	1 3/4"				3 1/2" or 2-Ply 1 3/4"					5 1/4" or 3-Ply 1 3/4"					7" 4-Ply 1 3/4" or 2-Ply 3 1/2"							
	Beam Depth				Beam Depth					Beam Depth					Beam Depth							
	7 1/4"	9 1/2"	11 7/8"	14"	7 1/4"	9 1/2"	11 7/8"	14"	16"	18"	9 1/2"	11 7/8"	14"	16"	18"	20"	11 7/8"	14"	16"	18"	20"	24"
6	954	1,330	1,782	2,245	1,908	2,660	3,564	4,491	4,796	4,794	3,990	5,346	6,736	7,194	7,191	7,188	7,128	8,981	9,592	9,588	9,584	9,576
	-	-	-	-	-	-	-	-	-	-	-	-	-	-	-	-	-	-	-	-	-	-
7	2.2/5.5	3.1/7.6	4.1/10.2	5.1/12.9	2.2/5.5	3.1/7.6	4.1/10.2	5.1/12.9	5.5/13.8	5.5/13.8	3.1/7.6	4.1/10.2	5.1/12.9	5.5/13.8	5.5/13.8	5.5/13.8	4.1/10.2	5.1/12.9	5.5/13.8	5.5/13.8	5.5/13.8	5.5/13.8
	795	1,097	1,452	1,807	1,591	2,194	2,904	3,613	4,109	4,107	3,291	4,356	5,420	6,163	6,160	6,157	5,807	7,226	8,217	8,213	8,209	8,201
8	678	-	-	-	1,357	-	-	-	-	-	-	-	-	-	-	-	-	-	-	-	-	-
	2.1/5.3	2.9/7.3	3.9/9.7	4.8/12.1	2.1/5.3	2.9/7.3	3.9/9.7	4.8/12.1	5.5/13.8	5.5/13.8	2.9/7.3	3.9/9.7	4.8/12.1	5.5/13.8	5.5/13.8	5.5/13.8	3.9/9.7	4.8/12.1	5.5/13.8	5.5/13.8	5.5/13.8	5.5/13.8
9	617	933	1,225	1,511	1,235	1,867	2,449	3,022	3,593	3,591	2,800	3,674	4,532	5,390	5,387	5,384	4,899	6,043	7,186	7,182	7,178	7,170
	466	-	-	-	931	-	-	-	-	-	-	-	-	-	-	-	-	-	-	-	-	-
10	1.9/4.7	2.9/7.1	3.8/9.4	4.6/11.6	1.9/4.7	2.9/7.1	3.8/9.4	4.6/11.6	5.5/13.8	5.5/13.8	2.9/7.1	3.8/9.4	4.6/11.6	5.5/13.8	5.5/13.8	5.5/13.8	3.8/9.4	4.6/11.6	5.5/13.8	5.5/13.8	5.5/13.8	5.5/13.8
	440	812	1,059	1,298	880	1,624	2,117	2,596	3,083	3,190	2,436	3,176	3,894	4,624	4,785	4,782	4,235	5,192	6,166	6,380	6,376	6,368
11	333	715	-	-	665	1,431	-	-	-	-	2,146	-	-	-	-	-	-	-	-	-	-	-
	1.5/3.8	2.8/7.7	3.7/9.1	4.5/11.2	1.5/3.8	2.8/7.7	3.7/9.1	4.5/11.2	5.3/13.3	5.5/13.8	2.8/7.7	3.7/9.1	4.5/11.2	5.3/13.3	5.5/13.8	5.5/13.8	3.7/9.1	4.5/11.2	5.3/13.3	5.5/13.8	5.5/13.8	5.5/13.8
12	324	693	932	1,138	648	1,386	1,864	2,275	2,689	2,869	2,079	2,797	3,413	4,033	4,304	4,301	3,729	4,550	5,378	5,738	5,734	5,726
	246	532	-	-	491	1,065	-	-	-	-	1,597	-	-	-	-	-	-	-	-	-	-	-
13	1.5/3.1	2.7/6.6	3.6/8.9	4.4/10.9	1.5/3.1	2.7/6.6	3.6/8.9	4.4/10.9	5.2/12.9	5.5/13.8	2.7/6.6	3.6/8.9	4.4/10.9	5.2/12.9	5.5/13.8	5.5/13.8	3.6/8.9	4.4/10.9	5.2/12.9	5.5/13.8	5.5/13.8	5.5/13.8
	245	537	833	1,012	489	1,073	1,665	2,024	2,384	2,607	1,610	2,498	3,037	3,576	3,910	3,907	3,330	4,049	4,767	5,213	5,209	5,201
14	186	406	762	-	372	812	1,523	-	-	-	1,218	2,285	-	-	-	-	3,046	-	-	-	-	-
	1.5/3	2.3/5.7	3.5/8.8	4.3/10.7	1.5/3	2.3/5.7	3.5/8.8	4.3/10.7	5.1/12.6	5.5/13.8	2.3/5.7	3.5/8.8	4.3/10.7	5.1/12.6	5.5/13.8	5.5/13.8	3.5/8.8	4.3/10.7	5.1/12.6	5.5/13.8	5.5/13.8	5.5/13.8
15	189	417	733	912	378	834	1,465	1,823	2,141	2,388	1,252	2,198	2,735	3,211	3,582	3,579	2,931	3,647	4,281	4,776	4,772	4,764
	144	317	597	-	289	633	1,194	-	-	-	950	1,791	-	-	-	-	2,389	-	-	-	-	-
16	1.5/3	1.9/4.8	3.4/8.4	4.2/10.5	1.5/3	1.9/4.8	3.4/8.4	4.2/10.5	4.9/12.3	5.5/13.8	1.9/4.8	3.4/8.4	4.2/10.5	4.9/12.3	5.5/13.8	5.5/13.8	3.4/8.4	4.2/10.5	4.9/12.3	5.5/13.8	5.5/13.8	5.5/13.8
	149	330	623	829	297	660	1,247	1,658	1,942	2,203	991	1,870	2,487	2,913	3,304	3,301	2,494	3,316	3,884	4,406	4,402	4,394
17	114	251	476	756	229	503	953	1,513	-	-	754	1,429	2,269	-	-	-	1,905	3,026	-	-	-	-
	1.5/3	1.7/4.1	3.1/7.8	4.1/10.4	1.5/3	1.7/4.1	3.1/7.8	4.1/10.4	4.8/12.1	5.5/13.8	1.7/4.1	3.1/7.8	4.1/10.4	4.8/12.1	5.5/13.8	5.5/13.8	3.1/7.8	4.1/10.4	4.8/12.1	5.5/13.8	5.5/13.8	5.5/13.8
18	119	265	508	734	238	571	1,017	1,467	1,777	2,044	796	1,525	2,201	2,666	3,066	3,063	2,033	2,934	3,554	4,088	4,084	4,076
	92	203	386	615	184	405	771	1,230	-	-	608	1,157	1,845	-	-	-	1,543	2,460	-	-	-	-
19	1.5/3	1.5/3.6	2.7/6.9	4/9.9	1.5/3	1.5/3.6	2.7/6.9	4/9.9	4.8/12	5.5/13.8	1.5/3.6	2.7/6.9	4/9.9	4.8/12	5.5/13.8	5.5/13.8	2.7/6.9	4/9.9	4.8/12	5.5/13.8	5.5/13.8	5.5/13.8
	96	216	416	638	193	432	832	1,276	1,638	1,882	649	1,248	1,914	2,456	2,823	2,857	1,664	2,552	3,275	3,763	3,809	3,801
20	75	166	317	506	150	332	633	1,013	1,473	-	497	950	1,519	2,210	-	-	1,266	2,252	2,946	-	-	-
	1.5/3	1.5/3.2	2.4/6	3.7/9.2	1.5/3	1.5/3.2	2.4/6	3.7/9.2	4.7/11.8	5.4/13.6	1.5/3.2	2.4/6	3.7/9.2	4.7/11.8	5.4/13.6	5.5/13.8	2.4/6	3.7/9.2	4.7/11.8	5.4/13.6	5.5/13.8	5.5/13.8
21	79	178	344	555	158	356	689	1,110	1,443	1,742	535	1,033	1,665	2,165	2,613	2,677	1,377	2,220	2,887	3,484	3,569	3,561
	62	137	263	421	124	275	526	843	1,230	1,707	412	788	1,264	1,845	2,561	-	1,051	1,686	2,460	3,415	-	-
22	1.5/3	1.5/3	2.1/5.3	3.4/8.6	1.5/3	1.5/3	2.1/5.3	3.4/8.6	4.4/11.1	5.4/13.4	1.5/3	2.1/5.3	3.4/8.6	4.4/11.1	5.4/13.4	5.5/13.8	2.1/5.3	3.4/8.6	4.4/11.1	5.4/13.4	5.5/13.8	5.5/13.8
	65	148	288	466	131	297	576	931	1,277	1,597	445	864	1,397	1,915	2,395	2,517	1,152	1,862	2,553	3,193	3,356	3,348
23	52	115	220	354	104	230	441	709	1,037	1,443	345	661	1,063	1,555	2,165	-	882	1,418	2,074	2,886	-	-
	1.5/3	1.5/3	1.9/4.8	3.1/7.7	1.5/3	1.5/3	1.9/4.8	3.1/7.7	4.2/10.5	5.2/13.1	1.5/3	1.9/4.8	3.1/7.7	4.2/10.5	5.2/13.1	5.5/13.8	1.9/4.8	3.1/7.7	4.2/10.5	5.2/13.1	5.5/13.8	5.5/13.8
24	55	125	243	394	109	249	486	788	1,137	1,422	374	729	1,182	1,705	2,133	2,376	972	1,576	2,274	2,845	3,168	3,160
	44	97	187	301	87	194	373	602	882	1,230	291	560	902	1,322	1,845	-	747	1,203	1,763	2,460	-	-
25	1.5/3	1.5/3	1.7/4.3	2.8/6.9	1.5/3	1.5/3	1.7/4.3	2.8/6.9	4/9.9	4.9/12.3	1.5/3	1.7/4.3	2.8/6.9	4/9.9	4.9/12.3	5.5/13.8	1.7/4.3	2.8/6.9	4/9.9	4.9/12.3	5.5/13.8	5.5/13.8
	46	106	207	336	92	211	413	672	991	1,275	317	620	1,008	1,487	1,912	2,249	827	1,344	1,983	2,549	2,999	2,991
26	37	83	160	257	74	166	319	515	756	1,056	249	479	772	1,133	1,584	2,130	638	1,029	1,511	2,112	2,839	-
	1.5/3	1.5/3	1.5/3.8	2.5/6.2	1.5/3	1.5/3	1.5/3.8	2.5/6.2	3.6/9.1	4.7/11.7	1.5/3	1.5/3.8	2.5/6.2	3.6/9.1	4.7/11.7	5.5/13.8	1.5/3.8	2.5/6.2	3.6/9.1	4.7/11.7	5.5/13.8	5.5/13.8
27	39	90	177	289	78	180	354	577	854	1,149	270	531	866	1,280	1,723	2,105	708	1,155	1,707	2,297	2,807	2,839
	32	71	137	222	64	142	275	444	652	913	214	412	666	979	1,370	1,845	549	887	1,305	1,827	2,460	-
28	1.5/3	1.5/3	1.5/3.5	2.3/5.6	1.5/3	1.5/3	1.5/3.5	2.3/5.6	3.3/8.3	4.4/11.1	1.5/3	1.5/3.5	2.3/5.6	3.3/8.3	4.4/11.1	5.4/13.6	1.5/3.5	2.3/5.6	3.3/8.3	4.4/11.1	5.4/13.6	5.5/13.8
	67	132	217	354	104	230	441	709	1,037	1,443	345	661	1,063	1,555	2,165	-	882	1,418	2,074	2,886	-	-
29	54	104	168	280	107	208	336	496	696	966	161	311	504	743	1,044	1,410	415	672	991	1,392	1,880	-
	1.5/3	1.5/3	1.9/4.7	3.1/7.7	1.5/3	1.5/3	1.9/4.7	3.1/7.7	4.2/10.5	5.2/13.1	1.5/3	1.9/4.7	3.1/7.7	4.2/10.5	5.2/13.1	5.5/13.8	1.9/4.7	3.1/7.7	4.2/10.5	5.2/13.1	5.5/13.8	5.5/13.8
30	51	101	167	280	101	202	333	497	704	1,037	152	303	500	746	1,056	1,436	404	667	994	1,408	1,915	2,357
	42	80	130	217	83	161	261	385	542	772	125	241	391	578	813	1,100	321	521	770	1,083	1,467	-
31	1.5/3	1.5/3	1.6/4	2.3/5.6	1.5/3	1.5/3	1.6/4	2.3/5.9	3.3/8.3	4.4/11.1	1.5/3	1.5/3	1.6/4	2.3/5.9	3.3/8.3	4.5/11.2	1.5/3	1.6/4	2.3/5.9	3.3/8.3	4.5/11.2	5.5/13.8
	39	79	130	217	78	157	261	390	555	772	116	236	391	585	832	1,135	314	521	781	1,109	1,513	2,172
32	33	63	103	167	65	127	206	30														

Versa-Lam LVL Beam Allowable Nailing

Closest Allowable Nail Spacing

Nail Size	Nailing Parallel to Glue Lines (Narrow Face) ⁽¹⁾						Nailing Perpendicular to Glue Lines (Wide Face)	
	Versa-Lam® LVL						All Versa-Lam® LVL Products	
	1½"		1¾"		3½" and wider			
	O.C.	End	O.C.	End	O.C.	End	O.C.	End
8d Box (0.113"ø x 2.5")	3"	1½"	2"	1"	2"	½"	2"	1"
8d Common (0.131"ø x 2.5")	3"	2"	3"	2"	2"	1"	2"	1"
10d and 12d Box (0.128"ø x 3", 3.25")	3"	2"	3"	2"	2"	1"	2"	1"
16d Box (0.135"ø x 3.5")	3"/5"	2"/2½"	3"/5"	2"/2½"	2"/3"	1"/2½"	2"	2"
10d and 12d Common and 16d Sinker (0.148"ø x 3", 3.25")	4"/6"	3"	4"/6"	3"	2"/4"	2"/3"	2"	2"
16d Common (0.162"ø x 3.5")	6"/8"	4"	6"/8"	3"/4"	2"/4"	2"/3"	2"/3"	2"/2½"

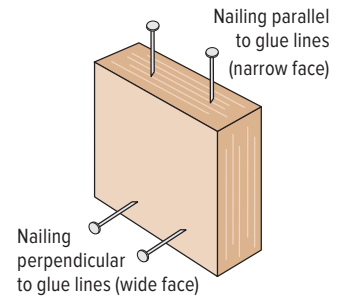

Red numbers indicate different nail spacing for Versa-Lam® LVL manufactured in Thorsby, AL.

(1) For 1¾" thickness and greater, two rows of nails (such as for a metal strap) are allowed (use ½" minimum offset between rows and stagger nails).

► Offset and stagger nail rows from floor sheathing and wall sole plate.

► Simpson Strong-Tie A35 and LPT4 connectors may be attached to the side of Versa-Lam® LVL. Use nails as specified by Simpson Strong-Tie.

Versa-Lam LVL Beam Design Values

Grade	Width	Depth	Weight (lb/ft)	Allowable Shear (lb)	Allowable Moment (ft-lb)	Moment of Inertia (in ⁴)
Versa-Stud® 1.8E 2650	1½"	3½"	1.5	998	776	5.4
		5½"	2.4	1,568	1,821	20.8
		7¼"	3.2	2,066	3,069	47.6
Versa-Lam® LVL 2.1E 3100	1¾"	3½"	1.8	1,164	1,058	6.3
		5½"	2.8	1,829	2,486	24.3
		7¼"	3.7	2,411	4,189	55.6
		9¼"	4.7	3,076	6,636	115.4
		9½"	4.8	3,159	6,979	125.0
		11¼"	5.7	3,741	9,605	207.6
		11½"	6.0	3,948	10,638	244.2
		14"	7.1	4,655	14,517	400.2
		16"	8.1	5,320	18,682	597.3
		18"	9.1	5,985	23,337	850.5
	24"	12.2	7,980	40,183	2,016.0	
	3½"	5½"	5.6	3,658	4,971	48.5
		7¼"	7.4	4,821	8,377	111.1
9¼"		9.4	6,151	13,272	230.8	
9½"		9.6	6,318	13,958	250.1	
11¼"		11.4	7,481	19,210	415.3	
11½"		12.1	7,897	21,275	488.4	
14"		14.2	9,310	29,035	800.3	
18"		18.3	11,970	46,674	1,701.0	

Grade	Width	Depth	Weight (lb/ft)	Allowable Shear (lb)	Allowable Moment (ft-lb)	Moment of Inertia (in ⁴)	
Versa-Lam® LVL 2.1E 3100	5¼"	5¼"	8.0	5,237	6,830	63.3	
		5½"	8.4	5,486	7,457	72.8	
		7¼"	11.0	7,232	12,566	166.7	
		9¼"	14.1	9,227	19,908	346.3	
		9½"	14.5	9,476	20,937	375.1	
		11¼"	17.1	11,222	28,814	622.9	
		11½"	18.1	11,845	31,913	732.6	
		14"	21.3	13,965	43,552	1,200.5	
		16"	24.4	15,960	56,046	1,792.0	
		18"	27.4	17,955	70,011	2,551.5	
		20"	30.4	19,950	85,428	3,500.0	
		24"	36.5	23,940	120,549	6,048.0	
		7"	9¼"	16.6	12,303	26,544	461.7
			9½"	17.1	12,635	27,916	500.1
	11¼"		20.2	14,963	38,419	830.6	
	11½"		21.4	15,794	42,550	976.8	
	14"		25.2	18,620	58,069	1,600.7	
	16"		28.8	21,280	74,728	2,389.3	
	18"		32.4	23,940	93,348	3,402.0	
	20"		36.0	26,600	113,904	4,666.7	
	24"		43.2	31,920	160,732	8,064.0	

Versa-Lam LVL Beam Allowable Stress Values

Design Property	Grade	Modulus of Elasticity True (Shear-Free) E (x 10 ⁶ psi) ⁽¹⁾⁽⁷⁾	Modulus of Elasticity Apparent E (x 10 ⁶ psi) ⁽¹⁾	Modulus of Elasticity for Stability E _{min} (x 10 ⁶ psi) ⁽¹⁾⁽⁸⁾	Bending F _b (psi) ⁽²⁾⁽³⁾	Horizontal Shear F _v (psi) ⁽²⁾⁽⁴⁾	Tension Parallel to Grain F _t (psi) ⁽²⁾⁽⁵⁾	Compression Parallel to Grain F _c (psi) ⁽²⁾	Compression Perpendicular to Grain F _{c⊥} (psi) ⁽¹⁾⁽⁶⁾	Equivalent Specific Gravity for Fastener Design (SG)
Versa-Lam® LVL Beams	2.1E 3100	2.1	2.0	1.1	3,100	285	2,150	3,000	750	0.5
Versa-Lam® LVL Studs	1.8E 2650	1.8	1.7	0.9	2,650	285	1,650	3,000	750	0.5
Versa-Lam® LVL Columns	1.8E 2650	1.8	1.7	0.9	2,650	285	1,650	3,000	750	0.5

NOTES

(1) Value cannot be adjusted for load duration.

(2) Value is based on 100% load duration and may be adjusted for other load durations.

(3) Fiber stress bending value shall be multiplied by the depth factor, (12/d)^{1/6} where d = member depth [in].

(4) Stress applied perpendicular to the glue lines.

(5) Tension value shall be multiplied by a length factor, (4/L)^{1/6} where L = member length [ft]. Use L = 4 for members less than four feet long.

(6) Stress applied parallel to the glue lines.

(7) True or shear-free modulus of elasticity does not account for shear deformation.

(8) E_{min} is the reference modulus of elasticity for beam and column stability calculations. It is calculated using E_{apparent} in accordance with Appendix D of the 2018 NDS. When calculating E_{min}, the coefficient of modulus of elasticity, COVe, may be taken as 0.10, and the adjustment factor to convert E to a pure bending basis may be taken as 1.05.

► Design properties are limited to dry conditions of use where the maximum moisture content of the material will not exceed 16%.

Versa-Lam LVL 1.8E 2650 Columns

Allowable Axial Load (lb)

Column Length	3½" x 3½"			3½" x 4¾"			3½" x 5¼"			3½" x 5½"			3½" x 7"			3½" x 7¼"		
	100%	115%	125%	100%	115%	125%	100%	115%	125%	100%	115%	125%	100%	115%	125%	100%	115%	125%
4'	14,700	16,090	16,930	18,390	20,130	21,180	22,070	24,165	25,430	23,130	25,320	26,640	29,450	32,240	33,920	30,500	33,390	35,130
5'	12,270	13,150	13,660	15,350	16,440	17,090	18,425	19,740	20,515	19,300	20,680	21,490	24,580	26,330	27,365	25,460	27,270	28,340
6'	10,080	10,650	10,980	12,610	13,320	13,740	15,140	15,995	16,495	15,860	16,750	17,280	20,195	21,335	22,000	20,910	22,090	22,780
7'	8,310	8,705	8,930	10,400	10,890	11,170	12,480	13,075	13,415	13,080	13,700	14,050	16,650	17,435	17,890	17,250	18,060	18,530
8'	6,930	7,205	7,370	8,660	9,010	9,210	10,405	10,825	11,070	10,900	11,340	11,600	13,880	14,440	14,760	14,370	14,960	15,290
9'	5,840	6,050	6,160	7,300	7,560	7,710	8,770	9,080	9,260	9,190	9,510	9,700	11,700	12,115	12,350	12,120	12,540	12,790
10'	4,980	5,135	5,225	6,230	6,420	6,540	7,480	7,715	7,850	7,830	8,080	8,220	9,975	10,290	10,470	10,330	10,660	10,840
11'	4,290	4,410	4,480	5,360	5,520	5,600	6,445	6,625	6,730	6,750	6,940	7,050	8,595	8,835	8,975	8,900	9,150	9,300
12'	3,730	3,825	3,880	4,660	4,780	4,850	5,600	5,745	5,830	5,870	6,020	6,100	7,475	7,665	7,775	7,740	7,940	8,050
13'	3,270	3,350	3,390	4,090	4,190	4,240	4,915	5,030	5,095	5,150	5,270	5,340	6,555	6,710	6,795	6,790	6,950	7,040
14'	2,890	2,950	2,990	3,610	3,690	3,740	4,340	4,435	4,490	4,550	4,650	4,700	5,790	5,915	5,990	6,000	6,130	6,200
Column Length	5¼" x 5¼"			5¼" x 5½"			5¼" x 7"			5¼" x 7¼"								
	100%	115%	125%	100%	115%	125%	100%	115%	125%	100%	115%	125%						
6'	33,070	36,220	38,110	34,670	37,950	39,930												
7'	29,420	31,730	33,085	30,830	33,240	34,660												
8'	25,875	27,570	28,565	27,110	28,880	29,930	34,525	36,790	38,115	35,760	38,090	39,480						
9'	22,690	23,970	24,715	23,770	25,110	25,900	30,275	31,985	32,980	31,360	33,130	34,160						
10'	19,930	20,920	21,495	20,880	21,920	22,520	26,600	27,920	28,685	27,550	28,920	29,710						
11'	17,585	18,375	18,820	18,420	19,250	19,720	23,465	24,510	25,125	24,310	25,400	26,010						
12'	15,590	16,220	16,585	16,340	16,990	17,380	20,805	21,650	22,130	21,550	22,420	22,930						
13'	13,895	14,410	14,700	14,560	15,100	15,400	18,545	19,225	19,620	19,210	19,920	20,320						
14'	12,450	12,870	13,115	13,040	13,480	13,740	16,615	17,180	17,500	17,210	17,790	18,130						
15'	11,210	11,560	11,760	11,740	12,110	12,320	14,960	15,425	15,695	15,490	15,980	16,260						
16'	10,135	10,430	10,600	10,620	10,930	11,110	13,525	13,920	14,150	14,010	14,420	14,650						
17'	9,205	9,455	9,600	9,650	9,910	10,060	12,285	12,620	12,810	12,730	13,070	13,270						
18'	8,395	8,610	8,735	8,800	9,020	9,150	11,205	11,495	11,655	11,610	11,900	12,070						
19'	7,685	7,870	7,975	8,050	8,250	8,360	10,260	10,505	10,645	10,620	10,880	11,030						
20'	7,060	7,220	7,310	7,400	7,560	7,660	9,420	9,635	9,760	9,760	9,980	10,110						
21'	6,505	6,645	6,725	6,820	6,960	7,050	8,680	8,870	8,980	8,990	9,190	9,300						

NOTES

- ▶ Table assumes that the column is braced at column ends only. Effective column length is equal to actual column length.
- ▶ Allowable loads are based on:
 - one-piece (solid) column members used in dry service conditions. BC Calc® software may be used for multi-piece column design.
 - an eccentricity value equal to 0.167 multiplied by either the column thickness or width (worst case).
 - axial loaded columns using the design provisions of the 2018 National Design Specification (NDS) for Wood Construction. Table capacity values based upon

a buckling length coefficient, (K_e) equal to 1.0 (rotation free, translation fixed at each column end per NDS Appendix G). A K_e coefficient of 1.0 conservatively models typical wood column applications. For other end fixity conditions, contact Boise Cascade EWP Engineering. For side or other combined bending and axial loads, see provisions in 2018 NDS.

- ▶ Load values are not shown for short lengths due to loads exceeding common connector capacities. Load values are not shown for longer lengths if the controlling slenderness ratio exceeds 50 (per NDS).
- ▶ Lateral loads (wind loading) are not considered in this table. BC Calc® software may be used for out-of-plane lateral load column application design.

Versa-Stud LVL 1.8E 2650

Reference Design Values

Product	Bending F_b (psi)	Compression Parallel to Grain $F_{c }$ (psi)	Compression Perp to Grain $F_{c\perp}$ (psi)	Modulus of Elasticity – Apparent E (psi)	Horizontal Shear F_v (psi)
Versa-Stud® 1.8E 2650 1½" x 5½"	2,856	3,000	450	1,700,000	285
Spruce Pine Fir (North) # 1/2 Grade 2 x 6	1,138	1,150	425	1,400,000	135
Hem-Fir # 2 Grade 2 x 6	1,105	1,300	405	1,300,000	150
Western Woods # 2 Grade 2 x 6	878	900	335	1,000,000	135

NOTES

- ▶ Design values are for loads applied to the narrow face of the studs.
- ▶ Dimension lumber values per NDS Supplement, Design Values for Wood Construction, 2018 Edition.

- ▶ Repetitive member factors have not been applied to the bending values. Depth (size) factors per ICC-ES®/APA® ESR-1040 and 2018 NDS have been applied to the corresponding bending values.

For additional design information, please see the Versa-Stud Eastern Tall Wall Guide.

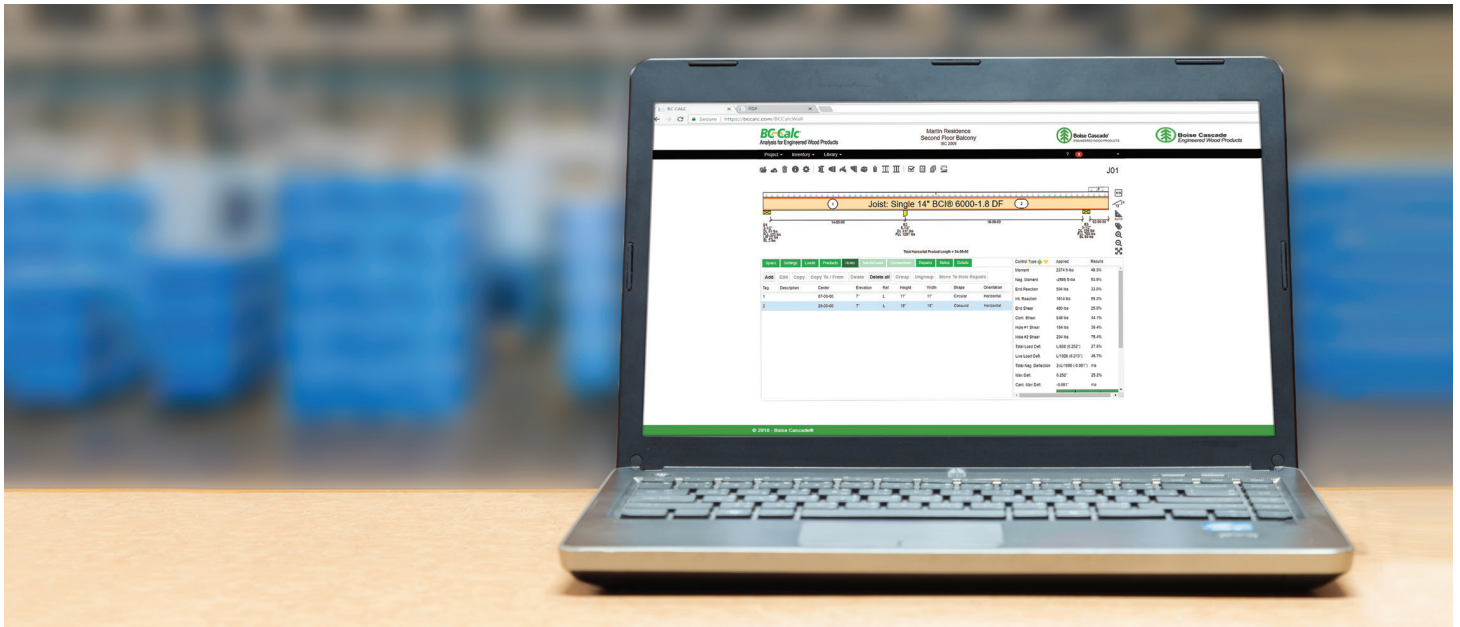

INTEGRATED SOFTWARE FOR EASY SPECIFICATION

All Boise Cascade's engineered wood products are incorporated into Boise Cascade's software suite. BC Framer®, BC Connect®, BC Calc®, and SawTek® all work together, seamlessly integrating design and processing technology into one automated system.

SOFTWARE BENEFITS

- ▶ Design member by member in BC Calc, or create a complete 3D model in BC Framer
- ▶ Dealers can manage projects and material lists and optimize manual or automated saw cut patterns in BC Connect
- ▶ SawTek's processing software cuts, drills, and labels job packs according to your specifications

With Boise Cascade's software suite, there's no need to worry about missing pieces or manual entry errors. The software applications share data digitally, ensuring nothing gets lost or mistyped.

Boise Cascade's software suite is available at www.bc.com/ewp/software/

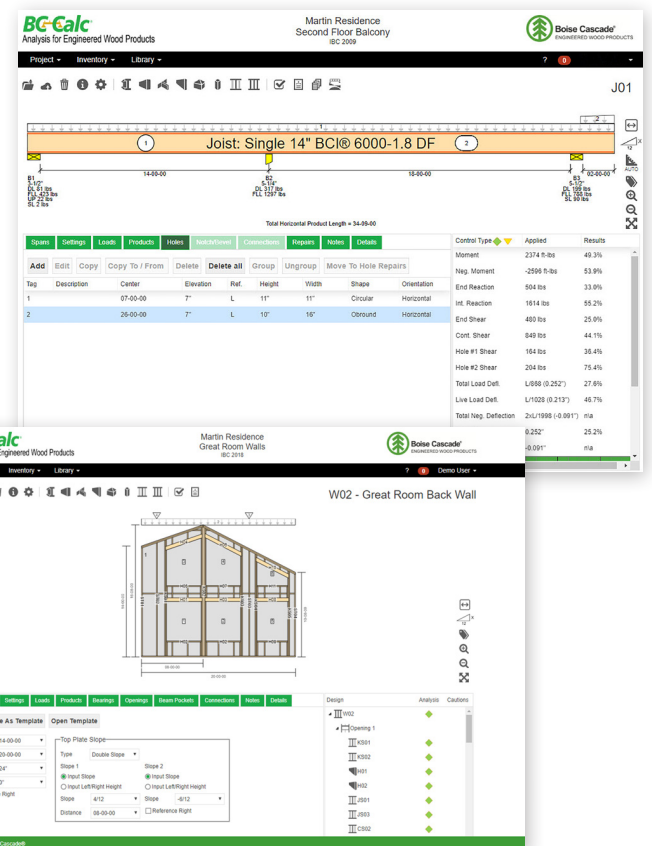

Single Joist – Top Flange

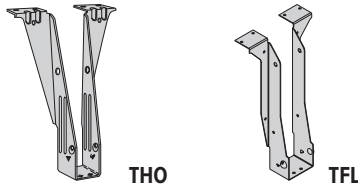

Joist Depth	AJS® Series	Hanger	Capacity (lbs)	Nailing	
				Header	Joist
9½"	20/140/150/190	TFL2595	1,006	(6) 10d	(2) 10d x 1½"
	25	THO35950	1,048	(10) 10d	(2) 10d x 1½"
11⅞"	20/140/150/190	TFL25118	1,020	(6) 10d	(2) 10d x 1½"
	25	THO35118	1,068	(10) 10d	(2) 10d x 1½"
14"	20/140/150/190	TFL2514	1,032	(6) 10d	(2) 10d x 1½"
	25	THO35140	1,086	(12) 10d	(2) 10d x 1½"
16"	20/140/150/190	TFL2516	1,048	(6) 10d	(2) 10d x 1½"
	25	THO35160	1,107	(12) 10d	(2) 10d x 1½"

Single Joist – Face Mount

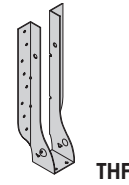

Joist Depth	AJS® Series	Hanger	Capacity (lbs)	Nailing	
				Header	Joist
9½"	20/140/150/190	THFI2595	960	(8) 10d	–
	25	IHFL35925	1,062	(10) 10d	–
11⅞"	20/140/150/190	THFI25118	1,085	(10) 10d	–
	25	IHFL35112	1,085	(12) 10d	–
14"	20/140/150/190	THFI2514	1,105	(12) 10d	–
	25	IHFL3514	1,105	(14) 10d	–
16"	20/140/150/190	IHFL2516	1,127	(14) 10d	–
	25	IHFL3516	1,127	(14) 10d	–

Double Joist – Top Flange



Joist Depth	AJS® Series	Hanger	Capacity (lbs)	Nailing	
				Header	Joist
9½"	20/140/150/190	THO25950-2	2,237	(10) 16d	(6) 10d
	25	PHM3595-2	2,840	(2) 16d	(2) 10d
11⅞"	20/140/150/190	THO25118-2	2,300	(10) 16d	(6) 10d
	25	PHM351188-2	3,060	(2) 16d	(2) 10d
14"	20/140/150/190	THO24140-2	2,355	(12) 16d	(6) 10d
	25	PHM3514-2	3,260	(2) 16d	(2) 10d
16"	20/140/150/190	THO25160-2	2,412	(12) 16d	(6) 10d
	25	PHM3516-2	3,390	(2) 16d	(2) 10d

Double Joist – Face Mount

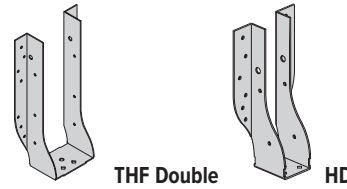

Joist Depth	AJS® Series	Hanger	Capacity (lbs)	Nailing	
				Header	Joist
9½"	20/140/150/190	IHF25925-2	2,125	(24) 16d	(2) 10d x 1½"
	25	HD7100	2,770	(18) 16d	(8) 16d
11⅞"	20/140/150/190	IHF25112-2	2,170	(24) 16d	(2) 10d x 1½"
	25	HD7120	3,390	(22) 16d	(8) 16d
14"	20/140/150/190	THF25140-2	2,210	(20) 10d	(6) 10d
	25	HD7140	4,005	(26) 16d	(12) 16d
16"	20/140/150/190	THF25160-2	2,255	(24) 10d	(6) 10d
	25	HD7160	3,305	(24) 16d	(8) 10d

NOTES

- (1) Flanges on the back of hanger may extend above top of joist.
- ▶ **Bold shaded** hangers require web stiffeners at joist ends. Web stiffeners may be required for non-shaded hangers by Boise Cascade.
- ▶ Capacities will vary with different nailing criteria and/or support conditions: contact supplier or MiTek Structural Connectors for further information.
- ▶ Capacity values shown are either hanger capacity values (see support requirements below) or AJS® joist end reaction capacities— whichever is less.
- ▶ All capacity values are downward loads at 100% load duration.
- ▶ Use sloped seat hangers and beveled web stiffeners when AJS® joist slope exceeds ¼" per foot.
- ▶ Leave 1/16" clearance (½" maximum) between the end of the supported joist and the head of the hanger.
- ▶ For AJS® joist applications, consult MiTek for capacity reduction.

Support Requirements

- ▶ Support material assumed to be Boise Cascade structural composite lumber or sawn lumber (Douglas fir or southern pine species).
- ▶ Minimum support width for single- and double-joist top mount hangers is 3"; (1½" for THO hangers).
- ▶ Minimum support width for face mount hangers with 10d and 16d nails is 1¾" and 2", respectively.



For more information, contact
MiTek Structural Connectors
at 1-800-328-5934 or
MiTek-US.com

Face Mount Skewed 45° Joist Hanger

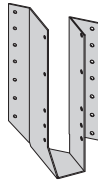

SKH

Joist Depth	AJS® Series	Hanger	Capacity (lbs)	Nailing	
				Header	Joist
9½"	20/140/150/190	SKH2520L/R	992	(14) 10d	(10) 10d x 1½"
	25	SKH410L/R	1,062	(16) 16d	(10) 16d
11⅞"	20/140/150/190	SKH2520L/R	1,003	(14) 10d	(10) 10d x 1½"
	25	SKH410L/R	1,085	(16) 16d	(10) 16d
14"	20/140/150/190	SKH2524L/R	1,014	(16) 10d	(10) 10d x 1½"
	25	SKH414L/R	1,105	(22) 16d	(10) 16d
16"	20/140/150/190	SKH2524L/R	1,029	(16) 10d	(10) 10d x 1½"
	25	SKH414L/R	1,127	(22) 16d	(10) 16d

Variable Pitch Joist Connector

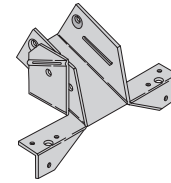

TMP

Joist Depth	AJS® Series	Hanger	Capacity (lbs)	Nailing	
				Header	Roof Joist
9½"	20/140/150/190	TMP25	1,175	(6) 10d	(4) 10d x 1½"
	25	TMP4	1,175	(6) 10d	(4) 10d x 1½"
11⅞"	20/140/150/190	TMP25	1,215	(6) 10d	(4) 10d x 1½"
	25	TMP4	1,215	(6) 10d	(4) 10d x 1½"
14"	20/140/150/190	TMP25	1,250	(6) 10d	(4) 10d x 1½"
	25	TMP4	1,250	(6) 10d	(4) 10d x 1½"
16"	20/140/150/190	TMP25	1,285	(6) 10d	(4) 10d x 1½"
	25	TMP4	1,285	(6) 10d	(4) 10d x 1½"

Adjustable Height Joist Hanger

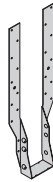

MSH

Joist Depth	AJS® Series	Hanger	Capacity (lbs)	Nailing	
				Header	Joist
9½"	20/140/150/190	MSH322	1,270	(22) 10d	(4) 10d x 1½"
	25	MSH422IF	1,270	(22) 10d	(6) 10d
11⅞"	20/140/150/190	MSH322	1,367	(22) 10d	(4) 10d x 1½"
	25	MSH422IF	1,367	(22) 10d	(6) 10d
14"	20/140/150/190	MSH322	1,455	(22) 10d	(4) 10d x 1½"
	25	MSH422IF	1,455	(22) 10d	(6) 10d
16"	20/140/150/190	MSH322	1,413	(22) 10d	(4) 10d x 1½"
	25	MSH422IF	1,413	(22) 10d	(6) 10d

Field Slope and Skew Joist Hanger

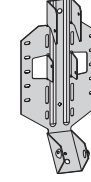

LSSH

Joist Depth	AJS® Series	Hanger	Capacity (lbs)	Nailing	
				Header	Joist
9½"	20/140/150/190	LSSH25-TZ	1,420	(14) 16d	(12) 10d x 1½"
	25	LSSU35-TZ	1,420	(14) 16d	(12) 10d x 1½"
11⅞"	20/140/150/190	LSSH25-TZ	1,530	(14) 16d	(12) 10d x 1½"
	25	LSSU35-TZ	1,530	(14) 16d	(12) 10d x 1½"
14"	20/140/150/190	LSSH25-TZ	1,610	(14) 16d	(12) 10d x 1½"
	25	LSSU35-TZ	1,610	(14) 16d	(12) 10d x 1½"
16"	20/140/150/190	LSSH25-TZ	1,610	(14) 16d	(12) 10d x 1½"
	25	LSSU35-TZ	1,610	(14) 16d	(12) 10d x 1½"

NOTES

- (1) Flanges on the back of hanger may extend above top of joist.
- ▶ **Bold shaded** hangers require web stiffeners at joist ends. Web stiffeners may be required for non-shaded hangers by Boise Cascade.
- ▶ Capacities will vary with different nailing criteria and/or support conditions: contact supplier or MiTek Structural Connectors for further information.
- ▶ Capacity values shown are either hanger capacity values (see support requirements below) or AJS® joist end reaction capacities— whichever is less.
- ▶ All capacity values are downward loads at 100% load duration.
- ▶ Use sloped seat hangers and beveled web stiffeners when AJS® joist slope exceeds ¼" per foot.
- ▶ Leave 1/16" clearance (1/8" maximum) between the end of the supported joist and the head of the hanger.
- ▶ For AJS® joist applications, consult MiTek for capacity reduction.

Support Requirements

- ▶ Support material assumed to be Boise Cascade structural composite lumber or sawn lumber (Douglas fir or southern pine species).
- ▶ Minimum support width for single- and double-joist top mount hangers is 3": (1½" for THO hangers).
- ▶ Minimum support width for face mount hangers with 10d and 16d nails is 1¾" and 2", respectively.



For more information, contact
MiTek Structural Connectors
at 1-800-328-5934 or
MiTek-US.com

Single Joist – Top Flange

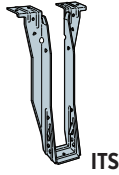

Joist Depth	AJS® Series	Hanger	Capacity (lbs)	Nailing	
				Header	Joist
9½"	20/140/150/190	ITS2.56/9.5	1,006	(6) 10d	–
	25	ITS3.56/9.5	1,006	(6) 10d	–
11⅞"	20/140/150/190	ITS2.56/11.88	1,020	(6) 10d	–
	25	ITS3.56/11.88	1,020	(6) 10d	–
14"	20/140/150/190	ITS2.56/14	1,032	(6) 10d	–
	25	ITS3.56/14	1,032	(6) 10d	–
16"	20/140/150/190	ITS2.56/16	1,048	(6) 10d	–
	25	ITS3.56/16	1,048	(6) 10d	–

Single Joist – Face Mount

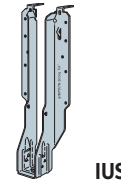

Joist Depth	AJS® Series	Hanger	Capacity (lbs)	Nailing	
				Header	Joist
9½"	20/140/150/190	IUS2.56/9.5	950	(8) 10d	–
	25	IUS3.56/9.5	1,006	(10) 10d	–
11⅞"	20/140/150/190	IUS2.56/11.88	1,020	(10) 10d	–
	25	IUS3.56/11.88	1,020	(12) 10d	–
14"	20/140/150/190	IUS2.56/14	1,032	(12) 10d	–
	25	IUS3.56/14	1,032	(12) 10d	–
16"	20/140/150/190	IUS2.56/16	1,048	(14) 10d	–
	25	IUS3.56/16	1,048	(14) 10d	–

Double Joist – Top Flange

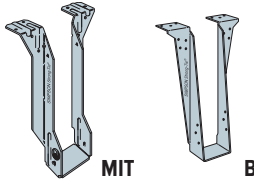

Joist Depth	AJS® Series	Hanger	Capacity (lbs)	Nailing	
				Header	Joist
9½"	20/140/150/190	MIT39.5-2	2,125	(8) 16d	(2) 10d x 1½"
	25	HWP7.12H=9.5	2,840	(9) 16d	(10) 16d
11⅞"	20/140/150/190	MIT311.8(8) 2	2,170	(8) 16d	(2) 10d x 1½"
	25	HWP7.12H=11.875	3,060	(9) 16d	(10) 16d
14"	20/140/150/190	MIT3(14) 2	2,210	(8) 16d	(2) 10d x 1½"
	25	HWP7.12H=14	3,260	(9) 16d	(10) 16d
16"	20/140/150/190	MIT5.12/16	2,255	(8) 16d	(2) 10d x 1½"
	25	HWP7.12H=16	3,452	(9) 16d	(10) 16d

Double Joist – Face Mount

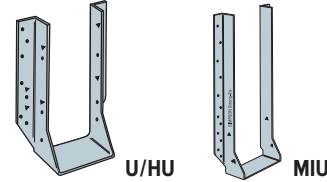

Joist Depth	AJS® Series	Hanger	Capacity (lbs)	Nailing	
				Header	Joist
9½"	20/140/150/190	MIU5.12/9	2,125	(16) 16d	(2) 10d x 1½"
	25	HU410-2	2,680	(18) 16d	(8) 16d
11⅞"	20/140/150/190	MIU5.12/11	2,170	(20) 16d	(2) 10d x 1½"
	25	HU412-2	2,930	(22) 16d	(8) 16d
14"	20/140/150/190	MIU5.12/14	2,210	(22) 16d	(2) 10d x 1½"
	25	HU414-2	3,120	(26) 16d	(12) 16d
16"	20/140/150/190	MIU5.12/16	2,255	(24) 16d	(2) 10d x 1½"
	25	HU414-2	3,305	(26) 16d	(12) 16d

NOTES

- ▶ **Bold shaded** hangers require web stiffeners.
- ▶ Capacities will vary with different nailing criteria and/or support conditions; contact supplier or Simpson Strong-Tie for further information.
- ▶ Capacity values shown are either hanger capacity values (see support requirements below) or AJS® joist end reaction capacities — whichever is less.
- ▶ All capacity values are downward loads at 100% load duration.
- ▶ Use sloped seat hangers and beveled web stiffeners when AJS® joist slope exceeds ¼" per foot.
- ▶ Leave ⅛" clearance (⅛" maximum) between the end of the supported joist and the head of the hanger.
- ▶ At max design capacity shown, hangers may exceed standard ⅛" deflection by ½".
- ▶ For VPA hanger, the two 10d x 1½" joist nails must be installed through the bend tabs at approximately a 45-degree angle.

Support Requirements

- ▶ *Support material assumed to be Boise Cascade structural composite lumber or sawn lumber (Douglas fir or southern pine species).*
- ▶ Minimum support width for single- and double-joist top mount hangers is 3".
- ▶ Minimum support width for face mount hangers with 10d and 16d nails is 1¼" and 2", respectively.



For more information,
contact Simpson Strong-Tie
at 1-800-999-5099 or
strongtie.com

Face Mount Skewed 45° Joist Hanger

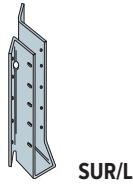

Joist Depth	AJS® Series	Hanger	Capacity (lbs)	Nailing	
				Header	Joist
9½"	20/140/150/190	SUR/L2.56/9	1,139	(14) 16d	(2) 10d x 1½"
	25	SUR/L410	1,076	(14) 16d	(6) 16d
11⅞"	20/140/150/190	SUR/L2.56/11	1,174	(16) 16d	(2) 10d x 1½"
	25	SUR/L410	1,101	(14) 16d	(6) 16d
14"	20/140/150/190	SUR/L2.56/14	1,204	(18) 16d	(2) 10d x 1½"
	25	SUR/L414	1,123	(18) 16d	(8) 16d
16"	20/140/150/190	SUR/L2.56/14	1,235	(18) 16d	(2) 10d x 1½"
	25	SUR/L414	1,127	(18) 16d	(8) 16d

Variable Pitch Joist Connector

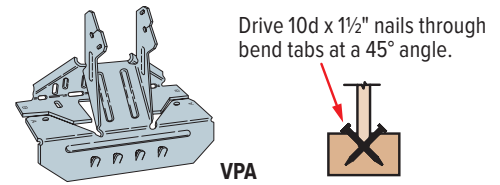

Joist Depth	AJS® Series	Hanger	Capacity (lbs)	Nailing	
				Header	Joist
9½"	20/140/150/190	VPA3	2,125	(16) 16d	(2) 10d x 1½"
	25	VPA4	2,680	(18) 16d	(8) 16d
11⅞"	20/140/150/190	VPA3	2,170	(20) 16d	(2) 10d x 1½"
	25	VPA4	2,930	(22) 16d	(8) 16d
14"	20/140/150/190	VPA3	2,210	(22) 16d	(2) 10d x 1½"
	25	VPA4	3,120	(26) 16d	(12) 16d
16"	20/140/150/190	VPA3	2,255	(24) 16d	(2) 10d x 1½"
	25	VPA4	3,305	(26) 16d	(12) 16d

Adjustable Height Joist Hanger

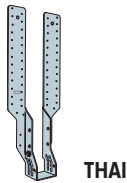

Joist Depth	AJS® Series	Hanger	Capacity (lbs)	Nailing	
				Header	Joist
9½"	20/140/150/190	THAI322	1,330	(4) 10d	(2) 10d x 1½"
	25	THAI422	1,330	(4) 10d	(2) 10d x 1½"
11⅞"	20/140/150/190	THAI322	1,432	(4) 10d	(2) 10d x 1½"
	25	THAI422	1,432	(4) 10d	(2) 10d x 1½"
14"	20/140/150/190	THAI322	1,465	(4) 10d	(2) 10d x 1½"
	25	THAI422	1,465	(4) 10d	(2) 10d x 1½"
16"	20/140/150/190	—	—	—	—
	25	—	—	—	—

Field Slope and Skew Joist Hanger

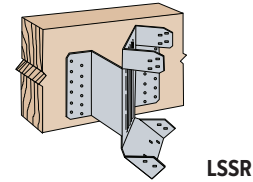

Joist Depth	AJS® Series	Hanger	Capacity (lbs)	Nailing	
				Header	Joist
9½"	20/140/150/190	LSSR2.56Z	1,175	(14) 10d x 1½"	(12) 10d x 1½"
	25	LSSR410Z	1,420	(22) 10d x 1½"	(18) 10d x 1½"
11⅞"	20/140/150/190	LSSR2.56Z	1,175	(14) 10d x 1½"	(12) 10d x 1½"
	25	LSSR410Z	1,420	(22) 10d x 1½"	(18) 10d x 1½"
14"	20/140/150/190	LSSR2.56Z	1,175	(14) 10d x 1½"	(12) 10d x 1½"
	25	LSSR410Z	1,420	(22) 10d x 1½"	(18) 10d x 1½"
16"	20/140/150/190	—	—	—	—
	25	—	—	—	—

NOTES

- ▶ **Bold shaded** hangers require web stiffeners.
- ▶ Capacities will vary with different nailing criteria and/or support conditions; contact supplier or Simpson Strong-Tie for further information.
- ▶ Capacity values shown are either hanger capacity values (see support requirements below) or AJS® joist end reaction capacities — whichever is less.
- ▶ All capacity values are downward loads at 100% load duration.
- ▶ Use sloped seat hangers and beveled web stiffeners when AJS® joist slope exceeds ¼" per foot.
- ▶ Leave ⅛" clearance (½" maximum) between the end of the supported joist and the head of the hanger.
- ▶ At max design capacity shown, hangers may exceed standard ⅛" deflection by ½".
- ▶ For VPA hanger, the two 10d x 1½" joist nails must be installed through the bend tabs at approximately a 45-degree angle.

Support Requirements

- ▶ *Support material assumed to be Boise Cascade structural composite lumber or sawn lumber (Douglas fir or southern pine species).*
- ▶ Minimum support width for single- and double-joist top mount hangers is 3".
- ▶ Minimum support width for face mount hangers with 10d and 16d nails is 1¾" and 2", respectively.



For more information,
contact Simpson Strong-Tie
at 1-800-999-5099 or
strongtie.com

Boise Cascade is one of the largest producers of engineered wood products in North America. With coast-to-coast distribution, we strive to meet our customer's needs through regional product offerings, on-time delivery, and continued technical support long after the sale. We know our success depends upon yours. And that's why we offer a full line of innovative engineered wood products that give you the strength, stability, and consistent performance you need for each project—and every challenge.

BCI® Joists

High-performance floors start with BCI® Joists — providing strong, high-quality results along with the consistency and easy handling needed to get the job done efficiently.

AJS® Joists

Boise Cascade AJS® joists are engineered to perform. With solid-sawn flanges manufactured with proprietary MSR (machine stress rated) lumber, they're made to deliver strength and consistency you can count on.

Boise Cascade® OSB Rimboard

Give floors the support they need with Boise Cascade® OSB Rimboard — a one-step, easy-to-install solution designed for use with BCI® and AJS® Joists.

Versa-Stud® Wall Framing

Whether tackling a grand stairway, tall window walls, or beyond, Versa-Stud LVL is manufactured with the reliability and strength needed to get the job done right.

Versa-Lam® LVL Beams and Headers

Get industry-leading overall value without sacrificing strength. Versa-Lam LVL beams and headers resist twisting, shrinking, and splitting — creating flatter, quieter floors that keep customers happy.

LVL Rimboard

Boise Cascade® Versa-Lam® LVL Rimboard makes it easy to keep projects moving without compromising performance. Consistent sizes simplify handling and installation, saving time and resources on site.

BOISE GLULAM®

Adaptable. Affordable. Easy to install. With a variety of sizes and appearance grades, BOISE GLULAM® products are some of the most appealing engineered wood solutions available.

Boise Cascade Software Solutions

From 3D design tools to workflow management and beyond, the Boise Cascade® suite of software is built to make lumberyards, distributors, and their teams operate faster, stronger, and easier.

Limited Lifetime Warranty

All Boise Cascade BCI® joist, Versa-Lam® LVL, and AJS® joist products are covered by a limited lifetime warranty for the expected life of the structure. View the complete warranty on our website.

bc.com/terms-conditions/sales-terms-and-conditions

NEED MORE INFORMATION?

Visit bc.com/ewp
or call 1-800-232-0788



Boise Cascade®
ENGINEERED WOOD PRODUCTS

Boise Cascade, AJS, BC Calc, BCI Joist, Versa-Lam LVL, and Versa-Stud are registered trademarks of Boise Cascade Company or its affiliates. © 2026 Boise Cascade Company. All rights reserved.

Information provided herein was current at the time of printing but may be superseded by an updated version. Visit bc.com/ewp to confirm that this is the most current guide.