



Boise Cascade[®]
WOOD PRODUCTS

Specifier Guide
BOISE GLULAM[®]



BOISE GLULAM BEAM AND COLUMN SPECIFIER GUIDE

BEAMS AND COLUMNS

208-337-3134

Reorder #GLM-5000

Strength and Beauty for Residential or Commercial Projects

BOISE GLULAM® Beams, Headers, and Columns.

Boise Cascade has been manufacturing glulam laminated beams for over 60 years. The quality control of our manufacturing process helps reassure you get the best quality product available for projects, every time.

Now Available – Wide Width, Architectural Appearance Grade Beams!

BOISE GLULAM beams are now available in wide widths of 3 1/2" and 5 1/2".

The wider widths simplify framing. It installs flush with standard framing material in walls, making a great solution even better. Framing crews can save time without having to fur out the small gap from narrower beams.

Not only can the BOISE GLULAM beam meet your needs and support heavy loads, but it looks beautiful while doing it.

The natural beauty of BOISE GLULAM beams is one that can't be matched. The visual appeal in exposed applications captures the gorgeous design envisioned for all projects leaving an indelible impression for years to come.

The stunning appearance is due to our manufacturing process that allows for the visual consistency of the beams. For years Boise Cascade has delivered the quality, consistency, and service customers have appreciated. This will not change, and now you have access to a truly stunning architectural visual grade beams, headers, and columns backed by a limited lifetime warranty.

Whether an industrial, residential, or commercial project, you can quickly get what you need when you need it. From traditional to contemporary styling, BOISE GLULAM beams and columns are manufactured primarily from Douglas Fir–Larch providing strength and beauty. The magnificence of these western softwood species allows for the production of Architectural, Industrial or Framing appearance classification beams and columns.

BOISE GLULAM beams, headers, and columns are a cost-effective and easy-to-install option for residential, commercial, and light industrial construction applications. It is usually simple to determine whether to specify a balanced or unbalanced layup and beams can be manufactured either with or without camber. You'll be sure to get the best option for your project with BOISE GLULAM.

FAST DELIVERY

For most residential applications, BOISE GLULAM beams are the product of choice and are available through our trusted distributors. These strong relationships, and local inventory means you get fast and accurate delivery.

BOISE GLULAM beams are manufactured in widths of 3 1/8", 5 1/8", 6 3/4", and 8 3/4"

BOISE GLULAM 3 1/2" and 5 1/2" wide beams offer architectural grade appearance and when exposed will raise the beauty of any project.

Depths range from 6" to 24" with lengths up to 66 feet. All are available with or without camber.

CUSTOM BEAMS

Do you have a project needing special custom beams? Does the project require longer lengths, curved or arched shapes, different appearances, or specific certifications? No problem.

TABLE OF CONTENTS

Product Storage and Handling	2
BOISE GLULAM Product Profiles	3
Technical Information	4
BOISE GLULAM 24F-V4 Design Values	5
BOISE GLULAM Column Tables	6
BOISE GLULAM 24F-V4 Allowable Design Stresses	8
Column Allowable Design Stresses	8
Allowable Holes	8
BOISE GLULAM Beams Common Details	9
BOISE GLULAM Beams Floor Load Tables	10–11
BOISE GLULAM Beams Roof Load Tables	16–27
BOISE GLULAM Beams Floor and Roof Application Tables	29–32
BOISE GLULAM Beams Substitution Tables	33–34
BOISE GLULAM® Beams Hanger Tables	36–37
Boise Cascade Software	39
Limited Lifetime Warranty	40

BOISE GLULAM® custom beams are manufactured on a made-to-order basis. Please call and speak with a representative to see how we can meet your needs.

Custom widths:
3 1/8", 3 1/2", 5 1/8", 5 1/2", 6 3/4", 8 3/4", 10 3/4", 12 1/4", 14 1/4"

Depths ranging from 6" to 57 1/2" (depending upon the width)

IJC (I-JOIST COMPATIBLE) BEAMS

IJC (I-Joist Compatible) sizes are readily available. Consult your local distributor for availability.

Protect product from rain and sun.

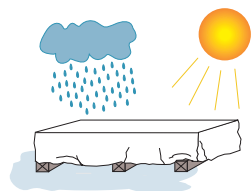

Keep product level and off the ground.

- ▶ Water-resistant wrapping is often specified to protect beams from moisture, soiling, and surface scratches during transit and job-site storage.

PRODUCT STORAGE AND HANDLING

- ▶ Because exposure to sunlight can discolor beams, opaque wrappings are recommended. Beams can be wrapped individually or by the bundle.
- ▶ In applications where appearance is especially important, individual wrapping should be left intact until installation to minimize exposure to job-site conditions.
- ▶ Beams are commonly loaded and unloaded with forklifts. For greater stability, the sides of the beams, rather than the bottoms, should rest on the forks. Supporting extremely long beams on their sides, however, can cause them to flex excessively, increasing the risk of damage. Use multiple forklifts to lift long beam members.
- ▶ A level, well-drained, covered storage site is recommended. Keep beams off the ground, using lumber blocking, skids, or a rack system. Keep beams level.
- ▶ The wrapping on beams should be left in place to protect them from moisture, soiling, sunlight, and scratches.
- ▶ For long-term storage, cut slits in the bottom of the wrapping to allow ventilation and draining of any entrapped moisture. Proper ventilation and drainage will reduce the likelihood of water damage, staining, and the start of decay.
- ▶ Failure to correctly store, use, or install BOISE GLULAM will void the limited warranty.

BOISE GLULAM Product Profiles

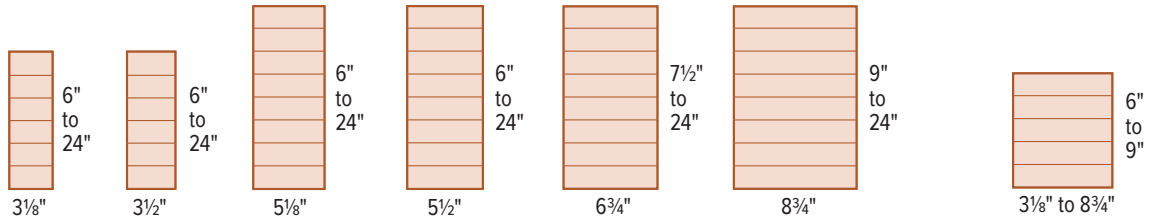

Architectural and Framing Appearance Beams

Columns

Larger widths and depths are available, contact your Boise Cascade EWP representative for availability

Appearance Grades

BOISE GLULAM® may be finished to several different appearance grades, which do not have any affect on strength values. As noted, stock beams in standard glulam widths (3 1/8", 5 1/8", 6 3/4", 8 3/4") are finished to the architectural appearance standard, the perfect look for most all applications. 3 1/2" and 5 1/2" wide beams have a framing grade appearance intended for enclosed applications. Premium appearance is available on a custom order basis for visible commercial and religious structure applications. For an old timber frame look, rough sawn appearance is available on all beams as well.

Architectural Appearance Beams

The beams of choice in applications where members are exposed show their smooth, attractive finish and highlight the beauty of wood. For consistency in appearance, voids greater than 3/4" are filled, three sides (excluding the top) are planed or sanded, and edges are eased on the bottom face of the member.

Industrial Appearance Beams

In concealed applications or in structures where appearance is not of primary importance, industrial appearance beams provide an excellent option for commercial buildings, warehouses, and garages. Voids are not filled, and only the two wide faces are planed.

Framing Appearance (Header) Beams

BOISE GLULAM® headers are commonly used in concealed spaces, such as within walls for headers above doors and windows, where appearance is not of importance.

Columns

Glulam columns are straight and dimensionally true, making framing an easy task. Because columns are available in long lengths, the members do not have to be spliced together, as is often necessary with sawn lumber. The columns can be exposed to view as a unique architectural feature of the structural frame.

All four edges of the columns are eased to match the widths of the Architectural Glulam beams and have the same architectural appearance. This consistency allows all four sides to be exposed to view.

Apparent and True Modulus of Elasticity

A beam's deflection is dependent upon the modulus of elasticity (MOE) and the beam's cross-section. There are two components of deflection, deformation from bending and deformation from shear. An "apparent" MOE is typically published for wood structural products. The apparent MOE encompasses both deflection components. However a "true" MOE value is sometimes referenced, which only corresponds to the bending portion of deflection and thus is "shear-free." A true MOE is approximately 5% higher

than the apparent MOE (the difference does vary slightly depending upon span length and beam depth). For example, the true MOE of a 24F-V4/DF glulam is 1,900,000 psi but the apparent MOE is 1,800,000 psi. The designer must add the shear deflection component to bending deflection when using the higher true MOE.

Balanced and Unbalanced Beam Layups

The most critical areas of a glulam beam are the outside laminations. Thus, the strongest laminations are placed in these areas in either unbalanced or balanced layups.

In unbalanced beams, typically known as V4, the bottom lamination is stronger than all the other laminations. This allows for a more efficient use of timber resources. It is very important to install unbalanced BOISE GLULAM® beams with the top side up. (The word "top" is always printed on the corresponding side.) V4 glulams may be designed and installed in both single and multiple-span applications, and in relatively short cantilevers.

Balanced glulam beams, or V8, have the same high-strength laminations on both the top and bottom of the beam, creating a symmetric layup. A V8 glulam can be designed for multiple-span conditions and cantilevers. V8 beams can also be used for single spans, but V4 beams are most cost-effective for this type of application. V8 BOISE GLULAM® beams may be special ordered.

Layup Combinations

Balanced Versus Unbalanced Layup Example

No 2D	T.L.	T.L. = Tension Lamination
No. 2	No. 1	
No. 2	No. 2	
No. 3	No. 3	
No. 2	No. 2	
No. 1	No. 1	
T.L.	T.L.	
Unbalanced (V4)	Balanced (V8)	

Technical Information

Deflection and Camber

For relatively long span lengths, deflection may control the design of glulam beams. Building codes limit deflection for floor and roof members with “L/over” limits. The “L” is simply the span length in inches. It can be divided by a number — for example, 360 for live load on floors — to determine the maximum amount of deflection a member can have for the corresponding span under full design loads. Thus, a greater amount of deflection is allowed for members with longer spans.

Camber is the amount of curvature (reverse deflection) that is built into a glulam beam during the manufacturing process to offset a portion of the design load deflection. Camber is specified to help reduce the aesthetic effect of long-span members. Camber can also be specified to reduce the amount of deflection or create roof drainage — for example, it may be used to limit water collection on near-flat roofs.

Adhesives

BOISE GLULAM® beams are manufactured with exterior-grade or wet-use adhesives to help ensure that the design values of the beams are not compromised when directly exposed to the weather during construction. Though wet-use adhesives are used, the beams still must be protected from exterior exposure. (For applications where moisture content may exceed 19%, see Preservative Treatment.)

(ANSI A190.1-2022 *Standard for Wood Products — Structural Glued Laminated Timber*) See “Exposed Applications for Glulam” later on this page.

Checking

Checking occurs naturally in timber when wood fibers dry. As the outer fibers lose moisture and attempt to shrink, they are restrained by the fiber in the inner portion of the beam, which loses moisture at a much slower rate. Rapid drying increases the difference in moisture content between the inner and outer fibers and thus the chances for checking in the timber member. To minimize the potential for checking, BOISE GLULAM® is produced from special grades of lumber specifically dried to a moisture content of less than 16%.

Field Notching and Drilling

Glulam beams are generally designed for applications where they will be highly stressed under design loads. For this reason, field modifications such as notching, tapering, or drilling may only be made after approval has been given by the project’s design professional of record and/or Boise Cascade Engineered Wood Products representative. For the proper location of smaller holes, please refer to Allowable Holes on page 9. Analysis of notches and tapered end cuts on BOISE GLULAM® beams may be performed by a qualified user of BC Calc®, Boise Cascade EWP’s engineered wood sizing software (www.BCCalc.com).

Dimensional Tolerances

The tolerances permitted at the time of manufacture per ANSI Standard A190.1-2022 are as follows:

- Width:*** Plus or minus $\frac{1}{16}$ " of the specified width.
- Depth:*** Plus $\frac{1}{8}$ " per foot of depth.
Minus $\frac{3}{16}$ ", or $\frac{1}{16}$ " per foot of depth, whichever is larger.
- Length:*** Up to 20 feet – Plus or minus $\frac{1}{16}$ ".
Over 20 feet – Plus or minus $\frac{1}{16}$ " per 20' of length.

*Does not apply to rough sawn textured beams.

Camber or Straightness — Tolerances are intended for use with straight or slightly cambered beams. The tolerances permitted at the time of manufacture, without allowance for dead load deflection, are as follows:

- Up to 20 feet: Plus or minus $\frac{1}{4}$ ".
- Over 20 feet: Add $\frac{1}{8}$ " per each additional 20' or fraction thereof, but not to exceed plus or minus $\frac{3}{4}$ ".

Squareness — The tolerance of the cross section shall be within plus or minus $\frac{1}{8}$ " per foot of specified depth, unless a specially shaped beam is selected.

Exposed Applications For Glulam

Consumer Information Sheets that detail proper use and handling of products with the specified treatments should be obtained from the treater for proper use and handling of products with the specified treatments. In addition, Material Safety Data Sheets (MSDS) and OSHA-required hazard labels provided with each preservative should be reviewed. Please note that when glulam beams are treated and installed in exterior applications, design values shall be adjusted per building code provisions.

Durable species glulam beams, such as Port Orford Cedar, are readily available and provide alternative product for exposed applications. This may be a good option for your top appearance applications. See Durable Species Flyer for additional information on options. Consult your local distributor for availability.

Fire Resistance

BOISE GLULAM® beams, like many other wood products, have advantageous fire-endurance properties. Unlike steel that loses a large percentage of its strength when exposed to typical temperatures during a fire, wood beams char on the surface. Charring forms a self-insulating surface layer when wood is exposed to flame or relatively high temperatures. The wood below this layer retains its structural properties during a fire. Most solid wood members, including BOISE GLULAM® beams, char at a nominal rate of approximately $1\frac{1}{2}$ " per hour. BOISE GLULAM® may be special ordered to create a beam with a one-hour fire rating. In this beam specification, an additional high grade tension lamination replaces a core lamination in the manufacturing process. The project’s design professional of record shall specify this type of fire-resistance requirement.

Larger glulam beams may be utilized in heavy timber construction, and a fire-resistance classification where exposed beams are designed to maintain a specified strength level for a specified duration during a fire. For further information on heavy timber construction, please refer to *Heavy Timber Construction - Wood Construction Data #5*, American Wood Council.

The adhesives used in BOISE GLULAM® beams do not reduce the fire-endurance properties of the wood material. When compared to wood, the adhesives have a higher ignition temperature and char in a very similar manner. When burned, the adhesives do not increase smoke toxicity. See Boise Cascade Fire Detail and Installation Guide for further design and detailing information. For further information on fire-resistance design, please contact Boise Cascade EWP Engineering.

BOISE GLULAM® Manufacturing Standards

APA Mill Number: 1107

APA EWS Trademarked Glulam Under These Standards:

- ANSI A190.1-2022

BOISE GLULAM 24F-V4 Design Values

Architectural and Framing Appearance Classification

Width	Depth	Weight (plf)	Allowable Shear (lbs)	Allowable Moment Positive ⁽¹⁾ (ft-lbs)	Allowable Moment Negative (Multiple Spans) ⁽¹⁾ (ft-lbs)	Moment of Inertia (in ⁴)
3 1/8"	6	4.6	3,313	3,750	2,891	56.3
	7 1/2	5.7	4,141	5,859	4,517	109.9
	9	6.8	4,969	8,438	6,504	189.8
	10 1/2	8.0	5,797	11,484	8,853	301.5
	12	9.1	6,625	15,000	11,563	450.0
	13 1/2	10.3	7,453	18,984	14,634	640.7
	15	11.4	8,281	23,438	18,066	878.9
	16 1/2	12.5	9,109	28,359	21,860	1,169.8
	18	13.7	9,938	33,750	26,016	1,518.8
3 1/2"	6	5.1	3,710	4,200	3,238	63.0
	7 1/2	6.4	4,638	6,563	5,059	123.0
	9	7.7	5,565	9,450	7,284	212.6
	10 1/2	8.9	6,493	12,863	9,915	337.6
	12	10.2	7,420	16,800	12,950	504.0
	13 1/2	11.5	8,348	21,263	16,390	717.6
	15	12.8	9,275	26,250	20,234	984.4
	16 1/2	14.0	10,203	31,763	24,484	1,310.2
	18	15.3	11,130	37,709	29,067	1,701.0
5 1/8"	6	7.5	5,433	6,150	4,741	92.3
	7 1/2	9.3	6,791	9,609	7,407	180.2
	9	11.2	8,149	13,838	10,666	311.3
	10 1/2	13.1	9,507	18,834	14,518	494.4
	12	14.9	10,865	24,600	18,963	738.0
	13 1/2	16.8	12,223	30,770	23,718	1,050.8
	15	18.7	13,581	37,589	28,975	1,441.4
	16 1/2	20.6	14,939	45,052	34,727	1,918.5
	18	22.4	16,298	53,151	40,970	2,490.8
	19 1/2	24.3	17,656	61,881	47,700	3,166.8
	21	26.2	19,014	71,237	54,912	3,955.2
	22 1/2	28.0	20,372	81,215	62,603	4,864.7
	24	29.9	21,730	91,810	70,771	5,904.0

Width	Depth	Weight (plf)	Allowable Shear (lbs)	Allowable Moment Positive ⁽¹⁾ (ft-lbs)	Allowable Moment Negative (Multiple Spans) ⁽¹⁾ (ft-lbs)	Moment of Inertia (in ⁴)
5 1/2"	6	8.0	5,830	6,600	5,088	99.0
	7 1/2	10.0	7,288	10,313	7,949	193.4
	9	12.0	8,745	14,850	11,447	334.1
	10 1/2	14.0	10,203	20,213	15,580	530.6
	12	16.0	11,660	26,214	20,207	792.0
	13 1/2	18.0	13,118	32,789	25,275	1,127.7
	15	20.1	14,575	40,056	30,876	1,546.9
	16 1/2	22.1	16,033	48,008	37,006	2,058.9
	18	24.1	17,490	56,638	43,659	2,673.0
	19 1/2	26.1	18,948	65,941	50,830	3,398.5
	21	28.1	20,405	75,912	58,515	4,244.6
	22 1/2	30.1	21,863	86,544	66,711	5,220.7
	24	32.1	23,320	97,835	75,414	6,336.0
6 3/4"	7 1/2	12.3	8,944	12,656	9,756	237.3
	9	14.8	10,733	18,225	14,048	410.1
	10 1/2	17.2	12,521	24,457	18,852	651.2
	12	19.7	14,310	31,520	24,297	972.0
	13 1/2	22.1	16,099	39,425	30,390	1,384.0
	15	24.6	17,888	48,163	37,126	1,898.4
	16 1/2	27.1	19,676	57,724	44,496	2,526.8
	18	29.5	21,465	68,102	52,495	3,280.5
	19 1/2	32.0	23,254	79,288	61,118	4,170.9
	21	34.5	25,043	91,276	70,359	5,209.3
	22 1/2	36.9	26,831	104,061	80,213	6,407.2
	24	39.4	28,620	117,636	90,678	7,776.0
	8 3/4"	9	19.1	13,913	23,048	17,766
10 1/2		22.3	16,231	30,891	23,812	844.1
12		25.5	18,550	39,812	30,689	1,260.0
13 1/2		28.7	20,869	49,798	38,386	1,794.0
15		31.9	23,188	60,834	46,893	2,460.9
16 1/2		35.1	25,506	72,911	56,202	3,275.5
18		38.3	27,825	86,018	66,306	4,252.5
19 1/2		41.5	30,144	100,147	77,197	5,406.7
21		44.7	32,463	115,290	88,869	6,752.8
22 1/2		47.9	34,781	131,438	101,317	8,305.7
24		51.0	37,100	148,585	114,534	10,080.0

NOTES

(1) Allowable moment calculated using glulam volume factor (C_v) with a span length of 21'. Allowable moment shall be multiplied by (21/Span Length [ft])^{1/10} for longer spans.

BOISE GLULAM Column Tables

Allowable Axial Load (lb) — Combination 3 Column Grade

Column Length (ft)	3 1/8" Wide Column						3 1/2" Wide Column					
	3 1/8" x 6"			3 1/8" x 7 1/2"			3 1/2" x 6"			3 1/2" x 7 1/2"		
	100%	115%	125%	100%	115%	125%	100%	115%	125%	100%	115%	125%
4	20,200	22,160	23,340	25,260	27,710	29,180	23,800	26,300	27,840	30,540	33,890	35,960
5	16,940	18,150	18,850	21,180	22,690	23,570	20,480	22,130	23,100	26,680	28,990	30,360
6	13,890	14,650	15,090	17,370	18,320	18,860	17,140	18,180	18,790	22,650	24,150	25,010
7	11,400	11,920	12,210	14,260	14,890	15,270	14,250	14,950	15,350	19,010	20,010	20,590
8	9,460	9,820	10,030	11,830	12,280	12,530	11,910	12,410	12,700	15,990	16,700	17,120
9	7,940	8,210	8,360	9,930	10,260	10,450	10,060	10,430	10,630	13,570	14,090	14,390
10	6,750	6,950	7,060	8,440	8,690	8,830	8,580	8,860	9,020	11,620	12,010	12,240
11	5,800	5,950	6,040	7,250	7,440	7,550	7,400	7,610	7,740	10,040	10,350	10,520
12	5,030	5,150	5,220	6,290	6,440	6,530	6,440	6,610	6,700	8,750	8,990	9,130
13	4,400	4,500	4,550	5,500	5,620	5,698	5,650	5,780	5,860	7,690	7,890	8,000
14							4,990	5,100	5,160	6,810	6,970	7,060
15												
16												
17												
18												
19												
20												
21												
22												

Column Length (ft)	5 1/8" Wide Column								
	5 1/8" x 5 1/8"			5 1/8" x 6"			5 1/8" x 7 1/2"		
	100%	115%	125%	100%	115%	125%	100%	115%	125%
4	31,380	35,530	38,170						
5	29,520	33,080	35,340	35,890	40,450	43,330			
6	27,360	30,300	32,110	33,760	37,640	39,950			
7	24,990	27,300	28,690	31,060	33,850	35,520	34,870	37,470	38,990
8	22,530	24,270	25,290	27,870	29,960	31,180	30,990	32,950	34,080
9	20,110	21,440	22,210	24,780	26,340	27,250	27,470	28,960	29,830
10	17,900	18,920	19,520	21,970	23,160	23,850	24,380	25,550	26,220
11	15,940	16,760	17,230	19,490	20,430	20,970	21,700	22,640	23,190
12	14,240	14,900	15,280	17,350	18,110	18,530	19,400	20,160	20,600
13	12,770	13,310	13,610	15,520	16,120	16,480	17,420	18,050	18,410
14	11,500	11,940	12,200	13,930	14,440	14,720	15,720	16,240	16,540
15	10,400	10,770	10,980	12,570	12,980	13,220	14,240	14,670	14,930
16	9,440	9,750	9,930	11,380	11,740	11,930	12,950	13,320	13,530
17	8,600	8,860	9,010	10,350	10,650	10,820	11,820	12,140	12,320
18	7,860	8,090	8,220	9,450	9,710	9,850	10,830	11,110	11,270
19	7,220	7,410	7,520	8,660	8,880	9,010	9,960	10,200	10,340
20	6,640	6,810	6,910	7,960	8,160	8,260	9,190	9,390	9,510
21	6,130	6,280	6,370	7,340	7,510	7,610	8,580	8,780	8,900
22									

NOTES: (for pages 6 and 7)

- ▶ Table assumes that the column is braced at column ends only. Effective column length is equal to actual column length.
- ▶ Allowable loads are based on:
 - one-piece column members used in dry service conditions.
 - an eccentricity value equal to 0.167 multiplied by the column thickness or width (worst case).
 - axial loading columns using the design provisions of the National Design Specification for Wood Construction (NDS), 2024 edition. For side or other combined bending and axial loads, use BC Calc® software to analyze such conditions.
- ▶ See page 8 for allowable design stresses.
- ▶ Load values are not shown for short lengths due to loads exceeding common connector capacities. Load values are not shown for longer lengths if the controlling slenderness ratio exceeds 50 (per NDS).
- ▶ It may be possible to exceed the limitations of the table by analyzing a specific application with the BC Calc® software.

BOISE GLULAM Column Tables

Allowable Axial Load (lb) — Combination 3 Column Grade

Column Length (ft)	5½" Wide Column								
	5½" x 5½"			5½" x 6"			5½" x 7½"		
	100%	115%	125%	100%	115%	125%	100%	115%	125%
4									
5									
6	32,110	35,670	37,880	36,080	40,220	42,800			
7	29,530	32,380	34,110	33,460	36,830	38,870			
8	26,810	28,990	30,290	30,600	33,220	34,760	40,390	43,830	45,870
9	24,090	25,760	26,740	27,650	29,560	30,630	36,490	39,110	40,640
10	21,540	22,840	23,590	24,680	26,090	26,910	32,730	34,750	35,920
11	19,260	20,290	20,880	21,980	23,090	23,730	29,310	30,890	31,810
12	17,260	18,080	18,560	19,620	20,510	21,030	26,280	27,540	28,270
13	15,510	16,190	16,570	17,590	18,310	18,710	23,620	24,660	25,250
14	13,990	14,550	14,870	15,820	16,410	16,750	21,310	22,160	22,650
15	12,670	13,140	13,400	14,290	14,780	15,070	19,290	20,010	20,410
16	11,510	11,910	12,140	12,960	13,380	13,620	17,530	18,130	18,480
17	10,500	10,840	11,030	11,800	12,160	12,360	15,990	16,500	16,790
18	9,620	9,900	10,070	10,780	11,090	11,260	14,640	15,070	15,320
19	8,830	9,080	9,220	9,890	10,150	10,300	13,440	13,820	14,030
20	8,140	8,350	8,480	9,100	9,330	9,460	12,380	12,710	12,900
21	7,520	7,710	7,820	8,400	8,600	8,710	11,440	11,730	11,890
22	6,970	7,130	7,230	7,780	7,950	8,050	10,600	10,850	10,990

Column Length [ft]	6¾" Wide Column						8¾" Wide Column		
	6¾" x 6"			6¾" x 7½"			8¾" x 9"		
	100%	115%	125%	100%	115%	125%	100%	115%	125%
4									
5									
6									
7									
8									
9	35,920	38,870	40,620						
10	32,700	35,020	36,390						
11	29,620	31,470	32,540						
12	26,820	28,310	29,180	39,870	42,340	43,790			
13	24,310	25,530	26,240	36,390	38,420	39,600			
14	22,080	23,100	23,680	33,240	34,920	35,900			
15	20,100	20,960	21,460	30,410	31,830	32,640			
16	18,360	19,090	19,500	27,870	29,070	29,760			
17	16,820	17,440	17,800	25,620	26,650	27,230			
18	15,460	15,990	16,300	23,600	24,480	24,990			
19	14,250	14,710	14,970	21,800	22,570	23,000			
20	13,170	13,570	13,800	20,180	20,850	21,240			
21	12,200	12,550	12,750	18,730	19,320	19,650			
22	11,330	11,640	11,820	17,430	17,940	18,240	39,360	41,030	41,950
23	10,550	10,820	10,980	16,250	16,710	16,970	36,940	38,400	39,250
24	9,840	10,090	10,230	15,180	15,590	15,820	34,710	36,020	36,760
25							32,660	33,830	34,510
26							30,780	31,840	32,440
27							29,060	30,010	30,560
28							27,460	28,330	28,830
29							26,000	26,780	27,240
30							24,630	25,360	25,780

BOISE GLULAM 24F-V4 Allowable Design Stresses

Bending F_b (psi)		Horizontal Shear F_v (psi)	Modulus of Elasticity – Apparent E ($\times 10^6$) (psi)	Modulus of Elasticity – True E ($\times 10^6$) (psi)	Tension Parallel to Grain F_t (psi)	Compression Parallel to Grain $F_{c }$ (psi)	Compression Perpendicular to Grain $F_{c\perp}$ (psi)
Tension Zone in Tension (Positive)	Compression Zone in Tension (Negative)						
2,400	1,850	265	1.8*	1.9*	1,100	1,650	650

*See note on Apparent vs True MOE on page 3 for clarification

NOTES:

- ▶ The data is for stock beams. For information on sizes not listed, please use BC Calc® software or consult with Boise Cascade EWP Engineering.
- ▶ Designer of record shall review the glulam's application and consider the conditions of use. Contact Boise Cascade EWP Engineering for non-standard application design stresses and reduction factors for wet-use and stability conditions.

Column Allowable Design Stresses

Combination 3 Column Grade

Compression Parallel to Grain F_c [psi]	Bending F_b (psi)		Modulus of Elasticity E (psi)		Modulus of Elasticity for Lateral Stability E_{min} (psi)	Compression Perpendicular to Grain (limiting direction) F_c (psi)	Tension Parallel to Grain F_t (psi)
	Load Perpendicular to Gluelines	Load Parallel to Gluelines	Load Perpendicular to Gluelines	Load Parallel to Gluelines			
2,300	2,000	2,100	1,900,000	1,900,000	1,000,000	650	1,450

Equivalent specific gravity for fastener design: SG = 0.5.

Allowable Holes

Horizontal Holes

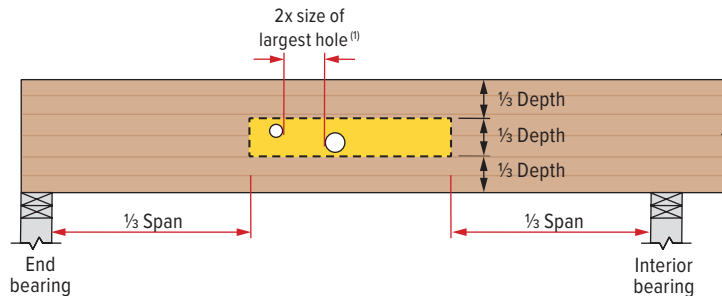

NOTES

- (1) The horizontal distance between adjacent holes must be at least two times the diameter of the larger hole. This restriction also applies to the location of holes relative to bolt holes in multiple ply beams. Holes shall not be stacked vertically.
- ▶ Round holes may be drilled or cut with a hole saw anywhere within the shaded area of the beam.
 - ▶ Do not drill more than three access holes in any 4' long section of beam.
 - ▶ The maximum round hole diameter permitted is:

Beam Depth	6" or 7½"	9" or greater
Maximum Hole Diameter	1"	2"

- ▶ Square and rectangular holes are not permitted.
- ▶ These limitations apply to holes drilled for plumbing or wiring access only. The size and location of holes drilled for fasteners are governed by the provisions of the *National Design Specification® for Wood Construction*.
- ▶ Beams deflect under load. Size holes to provide clearance where required.
- ▶ This prescriptive hole chart is valid for all BOISE GLULAM® beams. For beams with larger holes, use BC Calc® sizing software (www.BCCalc.com) or contact Boise Cascade EWP Engineering.
- ▶ For vertical holes, see page 32 for provisions with ridge beams or contact Boise Cascade EWP Engineering.

BOISE GLULAM Beams Common Details

G01 Bearing At Concrete/Masonry Walls

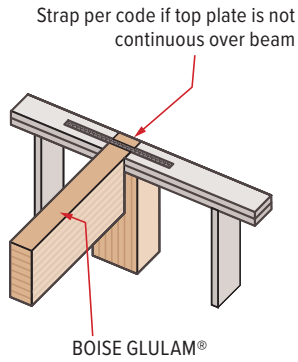

G02 Beam Bearing for Header

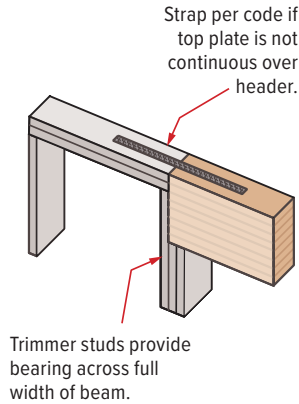

G03 Beam to Wall with Lateral Support

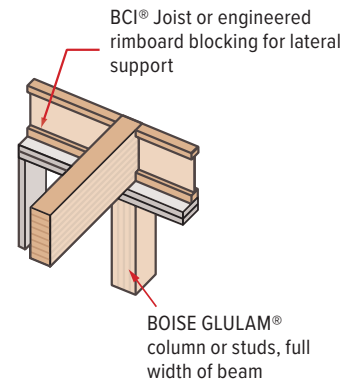

G04 End Wall Bevel Plate

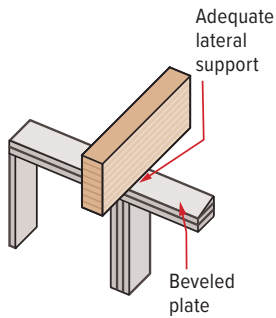

G05 Beam To Beam Connection

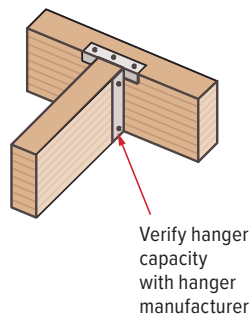

G06 Beam To Concrete/Masonry Walls

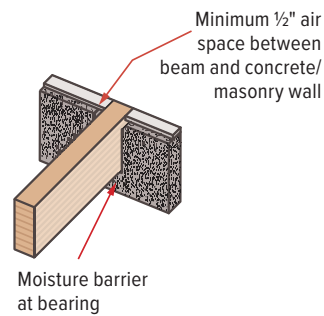

G07 Beam to Column Connection

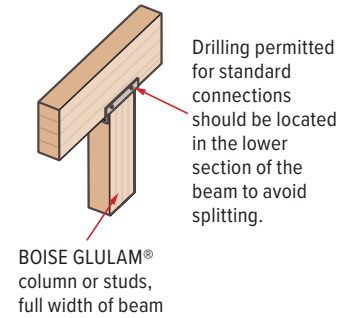

G08 Beam Depth Change at Intermediate Support

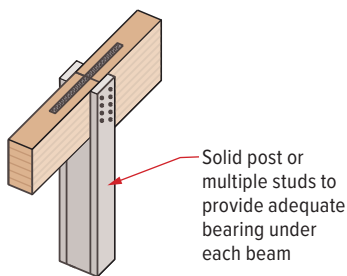

G09 Slope Seat Cut

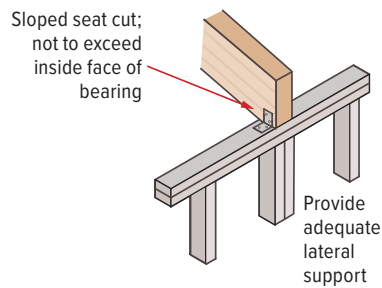

G10 Bevel Cut

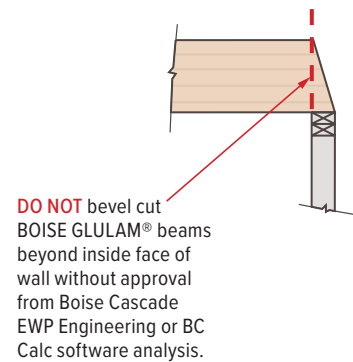

BOISE GLULAM Beams Floor Load Tables

Architectural Appearance Beams — 3 1/8"

24F-V4 Grade — 100% Load Duration

In pounds per lineal foot (PLF)

Span	Span Type	6"	7.5"	9"	10.5"	12"	13.5"	15"	16.5"	18"
6'	Simple	829	1,296	1,868	2,544	3,303	3,965	4,721	5,593	6,611
	Multiple	638	998	1,438	1,959	2,400	2,829	3,301	3,823	4,403
	Min. Bearing	1.5/3	1.9/3.7	2.8/5.3	3.8/7.3	4.9/8.9	5.9/10.5	7/12.2	8.3/14.2	9.8/16.3
8'	Simple	362	710	1,048	1,428	1,866	2,363	2,918	3,458	3,961
	Multiple	357	559	806	1,099	1,436	1,819	2,197	2,500	2,826
	Min. Bearing	1.5/3	1.5/3	2.1/4	2.8/5.4	3.7/7.1	4.7/9	5.8/10.9	6.8/12.4	7.8/14
10'	Simple	183	361	626	911	1,191	1,508	1,864	2,256	2,686
	Multiple	227	356	513	700	916	1,160	1,434	1,736	2,068
	Min. Bearing	1.5/3	1.5/3	1.6/3.2	2.3/4.4	3/5.7	3.7/7.2	4.6/8.9	5.6/10.8	6.6/12.8
12'	Simple	104	206	359	574	824	1,044	1,291	1,563	1,861
	Multiple	138	245	354	484	633	803	992	1,202	1,432
	Min. Bearing	1.5/3	1.5/3	1.5/3	1.7/3.6	2.5/4.7	3.1/6	3.8/7.4	4.7/9	5.5/10.7
14'	Simple	64	128	224	358	538	765	945	1,145	1,364
	Multiple	85	170	259	353	463	587	726	880	1,048
	Min. Bearing	1.5/3	1.5/3	1.5/3	1.5/3.1	1.9/4.1	2.7/5.1	3.3/6.4	4/7.7	4.7/9.1
16'	Simple	–	84	148	237	357	511	704	874	1,041
	Multiple	–	112	196	269	352	447	553	671	799
	Min. Bearing	–	1.5/3	1.5/3	1.5/3	1.5/3.6	2.1/4.5	2.8/5.6	3.5/6.7	4.2/8
18'	Simple	–	57	102	164	248	356	491	656	820
	Multiple	–	77	136	211	276	351	435	527	629
	Min. Bearing	–	1.5/3	1.5/3	1.5/3	1.5/3.2	1.6/4	2.2/4.9	3/6	3.7/7.1
20'	Simple	–	–	72	118	178	257	355	475	619
	Multiple	–	–	97	157	222	282	350	425	507
	Min. Bearing	–	–	1.5/3	1.5/3	1.5/3	1.5/3.6	1.8/4.4	2.4/5.4	3.1/6.4
22'	Simple	–	–	53	86	132	190	264	354	462
	Multiple	–	–	71	116	176	232	287	349	416
	Min. Bearing	–	–	1.5/3	1.5/3	1.5/3	1.5/3.3	1.5/4	2/4.9	2.6/5.8
24'	Simple	–	–	–	65	99	144	201	270	353
	Multiple	–	–	–	88	134	193	240	291	346
	Min. Bearing	–	–	–	1.5/3	1.5/3	1.5/3	1.5/3.7	1.7/4.5	2.2/5.3
26'	Simple	–	–	–	–	76	111	155	209	274
	Multiple	–	–	–	–	103	150	202	245	290
	Min. Bearing	–	–	–	–	1.5/3	1.5/3	1.5/3.4	1.5/4.1	1.8/4.9
28'	Simple	–	–	–	–	59	87	122	165	217
	Multiple	–	–	–	–	81	118	164	208	247
	Min. Bearing	–	–	–	–	1.5/3	1.5/3	1.5/3	1.5/3.8	1.6/4.5
30'	Simple	–	–	–	–	–	69	97	132	174
	Multiple	–	–	–	–	–	94	131	177	211
	Min. Bearing	–	–	–	–	–	1.5/3	1.5/3	1.5/3.5	1.5/4.2
32'	Simple	–	–	–	–	–	55	78	106	141
	Multiple	–	–	–	–	–	75	106	144	183
	Min. Bearing	–	–	–	–	–	1.5/3	1.5/3	1.5/3.1	1.5/3.9
34'	Simple	–	–	–	–	–	–	63	87	115
	Multiple	–	–	–	–	–	–	87	118	156
	Min. Bearing	–	–	–	–	–	–	1.5/3	1.5/3	1.5/3.5
36'	Simple	–	–	–	–	–	–	51	71	95
	Multiple	–	–	–	–	–	–	71	97	129
	Min. Bearing	–	–	–	–	–	–	1.5/3	1.5/3	1.5/3.2
38'	Simple	–	–	–	–	–	–	–	59	79
	Multiple	–	–	–	–	–	–	–	81	108
	Min. Bearing	–	–	–	–	–	–	–	1.5/3	1.5/3
40'	Simple	–	–	–	–	–	–	–	–	65
	Multiple	–	–	–	–	–	–	–	–	90
	Min. Bearing	–	–	–	–	–	–	–	–	1.5/3

NOTES

- ▶ Both Architectural and Framing appearance classification BOISE GLULAM® beams have the same structural classification, 24F-V4. Appearance classification does not affect the beam's allowable design values.
- ▶ Uniform PLF load values are limited by shear, moment, total load deflection limited to L/240 and live load deflection limited to L/360.
- ▶ Live load is equal to 0.8 of total load (residential loading).
- ▶ Table values assume that lateral support is provided at each support and continuously along the compression edge of the beam.
- ▶ Span is measured center to center of the supports.
- ▶ Table values for Minimum Required Bearing Lengths are based on the allowable compression design value perpendicular to grain for the beam and the load value shown. Other design considerations, such as a weaker support material, may warrant longer bearing lengths. Table values assume that support is provided across the full width of the beam.
- ▶ Table assumes dry-use conditions.
- ▶ Table was designed to apply to a broad range of applications. It may be possible to exceed the limitations of this table by analyzing a specific application with the BC Calc® software.

BOISE GLULAM Beams Floor Load Tables

Architectural Appearance Beams — 3½"

24F-V4 Grade — 100% Load Duration

In pounds per lineal foot (PLF)

Span	Span Type	6"	7.5"	9"	10.5"	12"	13.5"	15"	16.5"	18"
6'	Simple	928	1,452	2,092	2,849	3,700	4,441	5,287	6,264	7,405
	Multiple	714	1,118	1,611	2,194	2,688	3,169	3,697	4,282	4,931
	Min. Bearing	1.5 / 3	1.9 / 3.7	2.8 / 5.3	3.8 / 7.3	4.9 / 8.9	5.9 / 10.5	7 / 12.2	8.3 / 14.2	9.8 / 16.3
8'	Simple	410	801	1,174	1,599	2,090	2,646	3,268	3,873	4,437
	Multiple	400	626	903	1,230	1,609	2,037	2,461	2,800	3,165
	Min. Bearing	1.5 / 3	1.5 / 3	2.1 / 4	2.8 / 5.4	3.7 / 7.1	4.7 / 9	5.8 / 10.9	6.8 / 12.4	7.8 / 14
10'	Simple	210	410	709	1,020	1,334	1,690	2,087	2,527	3,009
	Multiple	254	398	575	784	1,026	1,300	1,606	1,945	2,316
	Min. Bearing	1.5 / 3	1.5 / 3	1.6 / 3.2	2.3 / 4.4	3 / 5.7	3.7 / 7.2	4.6 / 8.9	5.6 / 10.8	6.6 / 12.8
12'	Simple	122	237	410	651	923	1,170	1,446	1,751	2,085
	Multiple	160	275	397	542	709	899	1,111	1,346	1,603
	Min. Bearing	1.5 / 3	1.5 / 3	1.5 / 3	1.7 / 3.6	2.5 / 4.7	3.1 / 6	3.8 / 7.4	4.7 / 9	5.5 / 10.7
14'	Simple	77	149	258	410	612	856	1,059	1,282	1,528
	Multiple	101	197	290	396	518	657	813	985	1,174
	Min. Bearing	1.5 / 3	1.5 / 3	1.5 / 3	1.5 / 3.1	1.9 / 4.1	2.7 / 5.1	3.3 / 6.4	4 / 7.7	4.7 / 9.1
16'	Simple	51	100	173	275	410	584	801	979	1,166
	Multiple	67	132	220	301	394	501	620	751	895
	Min. Bearing	1.5 / 3	1.5 / 3	1.5 / 3	1.5 / 3	1.5 / 3.6	2.1 / 4.5	2.9 / 5.6	3.5 / 6.7	4.2 / 8
18'	Simple	–	70	122	193	288	410	563	749	918
	Multiple	–	92	160	236	310	393	487	590	704
	Min. Bearing	–	1.5 / 3	1.5 / 3	1.5 / 3	1.5 / 3.2	1.7 / 4	2.3 / 4.9	3 / 6	3.7 / 7.1
20'	Simple	–	51	89	141	210	299	410	546	709
	Multiple	–	67	117	185	249	316	392	476	567
	Min. Bearing	–	1.5 / 3	1.5 / 3	1.5 / 3	1.5 / 3	1.5 / 3.6	1.9 / 4.4	2.5 / 5.4	3.2 / 6.4
22'	Simple	–	–	67	106	158	225	308	410	532
	Multiple	–	–	88	139	204	259	322	391	463
	Min. Bearing	–	–	1.5 / 3	1.5 / 3	1.5 / 3	1.5 / 3.3	1.6 / 4	2.1 / 4.9	2.6 / 5.8
24'	Simple	–	–	51	81	122	173	237	316	410
	Multiple	–	–	67	107	160	216	268	324	383
	Min. Bearing	–	–	1.5 / 3	1.5 / 3	1.5 / 3	1.5 / 3	1.5 / 3.7	1.7 / 4.5	2.2 / 5.3
26'	Simple	–	–	–	64	96	136	187	248	323
	Multiple	–	–	–	84	126	179	225	271	321
	Min. Bearing	–	–	–	1.5 / 3	1.5 / 3	1.5 / 3	1.5 / 3.4	1.5 / 4.1	1.9 / 4.8
28'	Simple	–	–	–	51	77	109	149	199	258
	Multiple	–	–	–	67	101	143	191	230	273
	Min. Bearing	–	–	–	1.5 / 3	1.5 / 3	1.5 / 3	1.5 / 3.1	1.5 / 3.8	1.7 / 4.4
30'	Simple	–	–	–	–	62	89	122	162	210
	Multiple	–	–	–	–	82	117	160	197	234
	Min. Bearing	–	–	–	–	1.5 / 3	1.5 / 3	1.5 / 3	1.5 / 3.5	1.5 / 4.1
32'	Simple	–	–	–	–	51	73	100	133	173
	Multiple	–	–	–	–	67	96	132	171	202
	Min. Bearing	–	–	–	–	1.5 / 3	1.5 / 3	1.5 / 3	1.5 / 3.2	1.5 / 3.8
34'	Simple	–	–	–	–	–	61	83	111	144
	Multiple	–	–	–	–	–	80	110	146	176
	Min. Bearing	–	–	–	–	–	1.5 / 3	1.5 / 3	1.5 / 3	1.5 / 3.6
36'	Simple	–	–	–	–	–	50	70	94	122
	Multiple	–	–	–	–	–	67	92	123	155
	Min. Bearing	–	–	–	–	–	1.5 / 3	1.5 / 3	1.5 / 3	1.5 / 3.4
38'	Simple	–	–	–	–	–	–	59	80	103
	Multiple	–	–	–	–	–	–	79	105	136
	Min. Bearing	–	–	–	–	–	–	1.5 / 3	1.5 / 3	1.5 / 3.2
40'	Simple	–	–	–	–	–	–	–	68	89
	Multiple	–	–	–	–	–	–	–	90	117
	Min. Bearing	–	–	–	–	–	–	–	1.5 / 3	1.5 / 3

NOTES

- ▶ Both Architectural and Framing appearance classification BOISE GLULAM® beams have the same structural classification, 24F-V4. Appearance classification does not affect the beam's allowable design values.
- ▶ Uniform PLF load values are limited by shear, moment, total load deflection limited to L/240 and live load deflection limited to L/360.
- ▶ Live load is equal to 0.8 of total load (residential loading).
- ▶ Table values assume that lateral support is provided at each support and continuously along the compression edge of the beam.
- ▶ Span is measured center to center of the supports.
- ▶ Table values for Minimum Required Bearing Lengths are based on the allowable compression design value perpendicular to grain for the beam and the load value shown. Other design considerations, such as a weaker support material, may warrant longer bearing lengths. Table values assume that support is provided across the full width of the beam.
- ▶ Table assumes dry-use conditions.
- ▶ Table was designed to apply to a broad range of applications. It may be possible to exceed the limitations of this table by analyzing a specific application with the BC Calc® software.

BOISE GLULAM Beams Floor Load Tables

Architectural Appearance Beams — 5 1/8"

24F-V4 Grade — 100% Load Duration

In pounds per lineal foot (PLF)

Span	Span Type	6"	7.5"	9"	10.5"	12"	13.5"	15"	16.5"	18"	19.5"	21"	22.5"	24"
6'	Simple	1,359	2,126	3,064	4,172	5,418	6,502	7,742	9,173	10,843	12,816			
	Multiple	1,046	1,637	2,359	3,213	3,936	4,640	5,414	6,270	7,221	8,284			
	Min. Bearing	1.5/3	1.9/3.7	2.8/5.3	3.8/7.3	4.9/8.9	5.9/10.5	7/12.2	8.3/14.2	9.8/16.3	11.6/18.7			
8'	Simple	593	1,164	1,718	2,341	3,060	3,875	4,786	5,671	6,497	7,410	8,424	9,559	
	Multiple	585	917	1,322	1,802	2,355	2,983	3,603	4,101	4,634	5,207	5,824	6,491	
	Min. Bearing	1.5/3	1.5/3	2.1/4	2.8/5.4	3.7/7.1	4.7/9	5.8/10.9	6.8/12.4	7.8/14	8.9/15.7	10.1/17.6	11.5/19.6	
10'	Simple	300	591	1,027	1,494	1,953	2,474	3,056	3,700	4,406	5,172	5,824	6,491	7,213
	Multiple	372	583	842	1,148	1,502	1,903	2,352	2,848	3,391	3,793	4,199	4,628	5,083
	Min. Bearing	1.5/3	1.5/3	1.6/3.2	2.3/4.4	3/5.7	3.7/7.2	4.6/8.9	5.6/10.8	6.6/12.8	7.8/14.3	8.8/15.9	9.8/17.5	10.9/19.2
12'	Simple	170	338	589	941	1,352	1,713	2,117	2,563	3,053	3,585	4,159	4,744	5,364
	Multiple	227	402	581	793	1,039	1,316	1,627	1,971	2,348	2,758	3,200	3,594	3,921
	Min. Bearing	1.5/3	1.5/3	1.5/3	1.7/3.6	2.5/4.7	3.1/6	3.8/7.4	4.7/9	5.5/10.7	6.5/12.5	7.5/14.5	8.6/16.3	9.7/17.8
14'	Simple	105	210	367	588	882	1,254	1,550	1,878	2,237	2,606	3,002	3,424	3,873
	Multiple	140	279	424	579	759	963	1,191	1,443	1,719	2,003	2,308	2,633	2,978
	Min. Bearing	1.5/3	1.5/3	1.5/3	1.5/3.1	1.9/4.1	2.7/5.1	3.3/6.4	4/7.7	4.7/9.1	5.5/10.7	6.4/12.3	7.3/14	8.2/15.8
16'	Simple	68	137	242	389	586	838	1,154	1,426	1,684	1,963	2,261	2,580	2,918
	Multiple	91	184	322	441	578	733	907	1,095	1,293	1,507	1,737	1,982	2,243
	Min. Bearing	1.5/3	1.5/3	1.5/3	1.5/3	1.5/3.6	2.1/4.5	2.8/5.6	3.5/6.7	4.1/7.9	4.8/9.2	5.5/10.6	6.3/12.1	7.1/13.6
18'	Simple	—	94	167	270	407	584	805	1,076	1,310	1,527	1,760	2,008	2,272
	Multiple	—	126	223	345	453	576	708	850	1,005	1,172	1,351	1,542	1,745
	Min. Bearing	—	1.5/3	1.5/3	1.5/3	1.5/3.2	1.6/4	2.2/4.9	3/5.9	3.6/6.9	4.2/8.1	4.8/9.3	5.5/10.6	6.2/12
20'	Simple	—	66	119	193	293	421	582	779	1,015	1,219	1,406	1,604	1,815
	Multiple	—	89	159	258	364	460	564	677	801	934	1,077	1,230	1,392
	Min. Bearing	—	1.5/3	1.5/3	1.5/3	1.5/3	1.5/3.6	1.8/4.4	2.4/5.2	3.1/6.2	3.7/7.2	4.3/8.3	4.9/9.4	5.5/10.7
22'	Simple	—	—	86	142	216	312	433	580	757	967	1,146	1,308	1,481
	Multiple	—	—	117	190	289	373	458	551	652	760	877	1,002	1,134
	Min. Bearing	—	—	1.5/3	1.5/3	1.5/3	1.5/3.2	1.5/3.9	2/4.7	2.6/5.6	3.3/6.5	3.9/7.5	4.4/8.5	5/9.6
24'	Simple	—	—	64	106	163	237	329	442	578	739	928	1,085	1,228
	Multiple	—	—	88	144	219	308	378	455	539	629	726	830	940
	Min. Bearing	—	—	1.5/3	1.5/3	1.5/3	1.5/3	1.5/3.6	1.7/4.3	2.2/5.1	2.8/5.9	3.4/6.8	4/7.7	4.5/8.7
26'	Simple	—	—	—	81	125	182	255	343	450	576	724	895	1,034
	Multiple	—	—	—	110	169	245	317	382	452	528	610	697	790
	Min. Bearing	—	—	—	1.5/3	1.5/3	1.5/3	1.5/3.3	1.5/3.9	1.8/4.6	2.3/5.4	2.9/6.2	3.6/7.1	4.2/8
28'	Simple	—	—	—	62	97	143	200	271	356	457	574	711	867
	Multiple	—	—	—	86	132	193	269	324	384	449	518	593	672
	Min. Bearing	—	—	—	1.5/3	1.5/3	1.5/3	1.5/3	1.5/3.6	1.6/4.3	2/5	2.5/5.7	3.1/6.5	3.8/7.4
30'	Simple	—	—	—	—	76	113	159	216	285	367	462	573	699
	Multiple	—	—	—	—	105	154	215	277	329	385	445	509	577
	Min. Bearing	—	—	—	—	1.5/3	1.5/3	1.5/3	1.5/3.4	1.5/4	1.8/4.6	2.2/5.3	2.7/6	3.3/6.8
32'	Simple	—	—	—	—	60	90	128	175	231	298	376	467	571
	Multiple	—	—	—	—	84	124	174	236	284	333	385	441	500
	Min. Bearing	—	—	—	—	1.5/3	1.5/3	1.5/3	1.5/3.1	1.5/3.7	1.5/4.3	1.9/4.9	2.4/5.6	2.9/6.4
34'	Simple	—	—	—	—	—	72	104	142	189	244	309	385	471
	Multiple	—	—	—	—	—	100	142	193	248	290	336	385	437
	Min. Bearing	—	—	—	—	—	1.5/3	1.5/3	1.5/3	1.5/3.4	1.5/4	1.7/4.6	2.1/5.3	2.6/6
36'	Simple	—	—	—	—	—	58	84	117	156	202	256	320	392
	Multiple	—	—	—	—	—	82	117	160	212	255	295	338	384
	Min. Bearing	—	—	—	—	—	1.5/3	1.5/3	1.5/3	1.5/3.2	1.5/3.8	1.5/4.3	1.9/4.9	2.3/5.6
38'	Simple	—	—	—	—	—	—	69	96	129	168	214	267	329
	Multiple	—	—	—	—	—	—	96	133	177	225	261	299	340
	Min. Bearing	—	—	—	—	—	—	1.5/3	1.5/3	1.5/3	1.5/3.6	1.5/4.1	1.7/4.7	2/5.3
40'	Simple	—	—	—	—	—	—	56	79	107	141	180	225	278
	Multiple	—	—	—	—	—	—	80	111	148	193	231	265	302
	Min. Bearing	—	—	—	—	—	—	1.5/3	1.5/3	1.5/3	1.5/3.3	1.5/3.9	1.5/4.4	1.8/5

NOTES

- ▶ Both Architectural and Framing appearance classification BOISE GLULAM® beams have the same structural classification, 24F-V4. Appearance classification does not affect the beam's allowable design values.
- ▶ Uniform PLF load values are limited by shear, moment, total load deflection limited to L/240 and live load deflection limited to L/360.
- ▶ Live load is equal to 0.8 of total load (residential loading).
- ▶ Table values assume that lateral support is provided at each support and continuously along the compression edge of the beam.
- ▶ Span is measured center to center of the supports.
- ▶ Table values for Minimum Required Bearing Lengths are based on the allowable compression design value perpendicular to grain for the beam and the load value shown. Other design considerations, such as a weaker support material, may warrant longer bearing lengths. Table values assume that support is provided across the full width of the beam.
- ▶ Table assumes dry-use conditions.
- ▶ Table was designed to apply to a broad range of applications. It may be possible to exceed the limitations of this table by analyzing a specific application with the BC Calc® software.

BOISE GLULAM Beams Floor Load Tables

Architectural Appearance Beams — 5½"

24F-V4 Grade — 100% Load Duration

In pounds per lineal foot (PLF)

Span	Span Type	6"	7.5"	9"	10.5"	12"	13.5"	15"	16.5"	18"	19.5"	21"	22.5"	24"
6'	Simple	1,459	2,282	3,288	4,478	5,814	6,978	8,309	9,844	11,636	13,754	16,296	19,403	23,288
	Multiple	1,123	1,756	2,532	3,448	4,224	4,979	5,810	6,728	7,749	8,890	10,174	11,630	13,294
	Min. Bearing	1.5 / 3	1.9 / 3.7	2.8 / 5.3	3.8 / 7.3	4.9 / 8.9	5.9 / 10.5	7 / 12.2	8.3 / 14.2	9.8 / 16.3	11.6 / 18.7	13.7 / 21.4	16.3 / 24.5	19.6 / 28
8'	Simple	645	1,259	1,844	2,513	3,284	4,159	5,136	6,086	6,972	7,952	9,041	10,258	11,628
	Multiple	628	984	1,419	1,934	2,528	3,201	3,867	4,401	4,973	5,588	6,250	6,966	7,741
	Min. Bearing	1.5 / 3	1.5 / 3	2.1 / 4	2.8 / 5.4	3.7 / 7.1	4.7 / 9	5.8 / 10.9	6.8 / 12.4	7.8 / 14	8.9 / 15.7	10.1 / 17.6	11.5 / 19.6	13 / 21.7
10'	Simple	330	645	1,114	1,603	2,096	2,655	3,280	3,971	4,728	5,551	6,250	6,966	7,741
	Multiple	399	626	904	1,232	1,612	2,042	2,524	3,056	3,639	4,071	4,506	4,967	5,455
	Min. Bearing	1.5 / 3	1.5 / 3	1.6 / 3.2	2.3 / 4.4	3 / 5.7	3.7 / 7.2	4.6 / 8.9	5.6 / 10.8	6.6 / 12.8	7.8 / 14.3	8.8 / 15.9	9.8 / 17.5	10.9 / 19.2
12'	Simple	191	373	645	1,023	1,451	1,838	2,272	2,751	3,276	3,847	4,432	5,055	5,716
	Multiple	251	432	624	852	1,115	1,413	1,746	2,115	2,520	2,959	3,410	3,857	4,208
	Min. Bearing	1.5 / 3	1.5 / 3	1.5 / 3	1.7 / 3.6	2.5 / 4.7	3.1 / 6	3.8 / 7.4	4.7 / 9	5.5 / 10.7	6.5 / 12.5	7.5 / 14.4	8.5 / 16.3	9.6 / 17.8
14'	Simple	120	235	406	645	962	1,346	1,664	2,015	2,383	2,777	3,199	3,649	4,126
	Multiple	158	309	455	622	815	1,033	1,278	1,548	1,832	2,134	2,459	2,806	3,173
	Min. Bearing	1.5 / 3	1.5 / 3	1.5 / 3	1.5 / 3.1	1.9 / 4.1	2.7 / 5.1	3.3 / 6.4	4 / 7.7	4.7 / 9.1	5.5 / 10.6	6.3 / 12.2	7.2 / 13.9	8.1 / 15.7
16'	Simple	81	157	272	432	645	918	1,259	1,520	1,795	2,091	2,410	2,749	3,110
	Multiple	106	207	346	473	620	787	971	1,166	1,378	1,606	1,851	2,112	2,390
	Min. Bearing	1.5 / 3	1.5 / 3	1.5 / 3	1.5 / 3	1.5 / 3.6	2.1 / 4.5	2.9 / 5.5	3.4 / 6.6	4.1 / 7.8	4.7 / 9.1	5.5 / 10.5	6.2 / 12	7 / 13.5
18'	Simple	57	111	191	303	453	645	884	1,177	1,396	1,627	1,875	2,140	2,421
	Multiple	74	145	251	371	486	616	754	906	1,071	1,248	1,439	1,643	1,859
	Min. Bearing	1.5 / 3	1.5 / 3	1.5 / 3	1.5 / 3	1.5 / 3.2	1.7 / 4	2.3 / 4.9	3 / 5.8	3.6 / 6.9	4.2 / 8	4.8 / 9.2	5.5 / 10.5	6.2 / 11.9
20'	Simple	–	81	139	221	330	470	645	858	1,114	1,299	1,498	1,709	1,934
	Multiple	–	106	183	291	390	490	600	722	853	996	1,148	1,311	1,484
	Min. Bearing	–	1.5 / 3	1.5 / 3	1.5 / 3	1.5 / 3	1.5 / 3.6	1.9 / 4.3	2.5 / 5.2	3.2 / 6.1	3.7 / 7.1	4.3 / 8.2	4.9 / 9.4	5.5 / 10.6
22'	Simple	–	61	105	166	248	353	484	645	837	1,059	1,221	1,394	1,578
	Multiple	–	80	138	218	316	398	488	587	694	810	935	1,067	1,209
	Min. Bearing	–	1.5 / 3	1.5 / 3	1.5 / 3	1.5 / 3	1.5 / 3.2	1.6 / 3.9	2.1 / 4.7	2.6 / 5.5	3.3 / 6.4	3.8 / 7.4	4.4 / 8.4	5 / 9.5
24'	Simple	–	–	81	128	191	272	373	496	645	819	1,012	1,156	1,309
	Multiple	–	–	106	168	251	328	403	485	574	671	774	884	1,001
	Min. Bearing	–	–	1.5 / 3	1.5 / 3	1.5 / 3	1.5 / 3	1.5 / 3.6	1.7 / 4.3	2.2 / 5	2.8 / 5.8	3.5 / 6.7	4 / 7.7	4.5 / 8.7
26'	Simple	–	–	63	101	150	214	293	390	507	645	805	972	1,101
	Multiple	–	–	83	132	198	275	338	407	482	563	650	743	842
	Min. Bearing	–	–	1.5 / 3	1.5 / 3	1.5 / 3	1.5 / 3	1.5 / 3.3	1.5 / 3.9	1.9 / 4.6	2.4 / 5.4	3 / 6.2	3.6 / 7	4.1 / 7.9
28'	Simple	–	–	–	81	120	171	235	313	406	516	645	793	938
	Multiple	–	–	–	106	158	225	286	345	409	478	552	631	716
	Min. Bearing	–	–	–	1.5 / 3	1.5 / 3	1.5 / 3	1.5 / 3	1.5 / 3.6	1.7 / 4.2	2.1 / 4.9	2.6 / 5.7	3.2 / 6.5	3.8 / 7.3
30'	Simple	–	–	–	65	98	139	191	254	330	420	524	645	782
	Multiple	–	–	–	86	129	183	245	295	350	410	474	542	615
	Min. Bearing	–	–	–	1.5 / 3	1.5 / 3	1.5 / 3	1.5 / 3	1.5 / 3.3	1.5 / 3.9	1.9 / 4.6	2.3 / 5.3	2.8 / 6	3.4 / 6.8
32'	Simple	–	–	–	51	81	115	157	209	272	346	432	531	645
	Multiple	–	–	–	71	106	151	207	255	303	355	410	470	533
	Min. Bearing	–	–	–	1.5 / 3	1.5 / 3	1.5 / 3	1.5 / 3	1.5 / 3.1	1.5 / 3.7	1.7 / 4.3	2.1 / 4.9	2.5 / 5.6	3 / 6.3
34'	Simple	–	–	–	–	65	96	131	175	227	288	360	443	537
	Multiple	–	–	–	–	88	126	173	222	264	309	358	410	465
	Min. Bearing	–	–	–	–	1.5 / 3	1.5 / 3	1.5 / 3	1.5 / 3	1.5 / 3.4	1.5 / 4	1.8 / 4.6	2.2 / 5.2	2.7 / 5.9
36'	Simple	–	–	–	–	52	79	111	147	191	243	303	373	453
	Multiple	–	–	–	–	74	106	145	193	231	271	314	360	409
	Min. Bearing	–	–	–	–	1.5 / 3	1.5 / 3	1.5 / 3	1.5 / 3	1.5 / 3.2	1.5 / 3.7	1.7 / 4.3	2 / 4.9	2.4 / 5.6
38'	Simple	–	–	–	–	–	64	93	125	162	206	258	317	385
	Multiple	–	–	–	–	–	90	124	164	204	239	277	318	362
	Min. Bearing	–	–	–	–	–	1.5 / 3	1.5 / 3	1.5 / 3	1.5 / 3	1.5 / 3.5	1.5 / 4.1	1.8 / 4.6	2.2 / 5.2
40'	Simple	–	–	–	–	–	52	77	107	139	177	221	272	330
	Multiple	–	–	–	–	–	77	106	141	181	212	246	283	321
	Min. Bearing	–	–	–	–	–	1.5 / 3	1.5 / 3	1.5 / 3	1.5 / 3	1.5 / 3.3	1.5 / 3.8	1.7 / 4.4	2 / 4.9

NOTES

- ▶ Both Architectural and Framing appearance classification BOISE GLULAM® beams have the same structural classification, 24F-V4. Appearance classification does not affect the beam's allowable design values.
- ▶ Uniform PLF load values are limited by shear, moment, total load deflection limited to L/240 and live load deflection limited to L/360.
- ▶ Live load is equal to 0.8 of total load (residential loading).
- ▶ Table values assume that lateral support is provided at each support and continuously along the compression edge of the beam.
- ▶ Span is measured center to center of the supports.
- ▶ Table values for Minimum Required Bearing Lengths are based on the allowable compression design value perpendicular to grain for the beam and the load value shown. Other design considerations, such as a weaker support material, may warrant longer bearing lengths. Table values assume that support is provided across the full width of the beam.
- ▶ Table assumes dry-use conditions.
- ▶ Table was designed to apply to a broad range of applications. It may be possible to exceed the limitations of this table by analyzing a specific application with the BC Calc® software.

BOISE GLULAM Beams Floor Load Tables

Architectural Appearance Beams — 6¾"

24F-V4 Grade — 100% Load Duration

In pounds per lineal foot (PLF)

Span	Span Type	7.5"	9"	10.5"	12"	13.5"	15"	16.5"	18"	19.5"	21"	22.5"	24"
6'	Simple	2,800	4,035	5,495	7,135	8,564	10,197	12,081	14,280	16,880			
	Multiple	2,156	3,107	4,232	5,184	6,111	7,130	8,258	9,510	10,911			
	Min. Bearing	1.9/3.7	2.8/5.3	3.8/7.3	4.9/8.9	5.9/10.5	7/12.2	8.3/14.2	9.8/16.3	11.6/18.7			
8'	Simple	1,533	2,263	3,084	4,030	5,104	6,304	7,469	8,556	9,759	11,096	12,590	
	Multiple	1,207	1,741	2,373	3,102	3,929	4,745	5,401	6,103	6,858	7,671	8,549	
	Min. Bearing	1.5/3	2.1/4	2.8/5.4	3.7/7.1	4.7/9	5.8/10.9	6.8/12.4	7.8/14	8.9/15.7	10.1/17.6	11.5/19.6	
10'	Simple	779	1,352	1,967	2,572	3,258	4,025	4,873	5,802	6,800	7,671	8,549	9,501
	Multiple	768	1,109	1,512	1,978	2,507	3,097	3,750	4,466	4,996	5,531	6,096	6,695
	Min. Bearing	1.5/3	1.6/3.2	2.3/4.4	3/5.7	3.7/7.2	4.6/8.9	5.6/10.8	6.6/12.8	7.8/14.3	8.8/15.9	9.8/17.5	10.9/19.2
12'	Simple	445	776	1,239	1,780	2,256	2,788	3,364	3,972	4,626	5,328	6,077	6,872
	Multiple	530	766	1,045	1,368	1,734	2,143	2,587	3,055	3,559	4,099	4,676	5,164
	Min. Bearing	1.5/3	1.5/3	1.7/3.6	2.5/4.7	3.1/6	3.8/7.4	4.6/8.9	5.5/10.5	6.4/12.3	7.3/14.1	8.4/16.1	9.5/17.8
14'	Simple	276	483	774	1,161	1,652	2,023	2,427	2,865	3,338	3,845	4,386	4,961
	Multiple	367	559	763	1,000	1,268	1,553	1,864	2,202	2,566	2,956	3,373	3,815
	Min. Bearing	1.5/3	1.5/3	1.5/3.1	1.9/4.1	2.7/5.1	3.3/6.3	3.9/7.5	4.6/8.9	5.4/10.4	6.2/11.9	7.1/13.6	8/15.4
16'	Simple	181	319	513	771	1,104	1,520	1,827	2,157	2,514	2,897	3,305	3,738
	Multiple	242	424	580	761	954	1,168	1,402	1,656	1,931	2,225	2,539	2,872
	Min. Bearing	1.5/3	1.5/3	1.5/3	1.5/3.6	2.1/4.4	2.8/5.4	3.4/6.5	4/7.7	4.6/8.9	5.3/10.3	6.1/11.7	6.9/13.3
18'	Simple	123	220	355	536	769	1,060	1,417	1,678	1,956	2,254	2,572	2,910
	Multiple	166	293	455	590	740	906	1,089	1,287	1,501	1,730	1,974	2,234
	Min. Bearing	1.5/3	1.5/3	1.5/3	1.5/3.1	1.6/3.9	2.2/4.8	3/5.7	3.5/6.8	4.1/7.9	4.7/9	5.4/10.3	6.1/11.7
20'	Simple	87	156	254	385	555	766	1,026	1,337	1,562	1,800	2,054	2,325
	Multiple	118	210	340	469	589	722	867	1,026	1,196	1,380	1,575	1,783
	Min. Bearing	1.5/3	1.5/3	1.5/3	1.5/3	1.5/3.5	1.8/4.3	2.4/5.1	3.1/6	3.6/7	4.2/8.1	4.8/9.2	5.4/10.4
22'	Simple	62	114	187	285	411	570	764	997	1,272	1,467	1,675	1,896
	Multiple	85	154	251	380	478	586	705	834	974	1,123	1,283	1,452
	Min. Bearing	1.5/3	1.5/3	1.5/3	1.5/3	1.5/3.1	1.5/3.8	2/4.6	2.6/5.4	3.3/6.3	3.8/7.3	4.3/8.3	4.9/9.4
24'	Simple	–	84	140	215	312	433	582	761	974	1,216	1,389	1,573
	Multiple	–	115	189	289	394	484	583	690	806	930	1,062	1,203
	Min. Bearing	–	1.5/3	1.5/3	1.5/3	1.5/3	1.5/3.5	1.7/4.2	2.2/4.9	2.8/5.7	3.4/6.6	3.9/7.5	4.4/8.5
26'	Simple	–	63	106	165	240	335	452	593	759	954	1,169	1,323
	Multiple	–	88	145	223	323	405	488	579	676	781	892	1,011
	Min. Bearing	–	1.5/3	1.5/3	1.5/3	1.5/3	1.5/3.2	1.5/3.8	1.8/4.5	2.3/5.2	2.9/6	3.6/6.9	4/7.8
28'	Simple	–	–	82	128	188	264	357	469	601	757	936	1,127
	Multiple	–	–	113	174	254	343	414	491	574	663	758	860
	Min. Bearing	–	–	1.5/3	1.5/3	1.5/3	1.5/3	1.5/3.5	1.6/4.2	2/4.8	2.5/5.6	3.1/6.3	3.7/7.2
30'	Simple	–	–	63	100	149	210	285	375	483	609	754	921
	Multiple	–	–	89	138	203	284	355	421	492	569	651	738
	Min. Bearing	–	–	1.5/3	1.5/3	1.5/3	1.5/3	1.5/3.3	1.5/3.8	1.8/4.5	2.2/5.2	2.7/5.9	3.3/6.6
32'	Simple	–	–	–	79	119	169	230	304	392	495	615	752
	Multiple	–	–	–	110	163	229	306	364	426	493	564	640
	Min. Bearing	–	–	–	1.5/3	1.5/3	1.5/3	1.5/3	1.5/3.6	1.5/4.2	1.9/4.8	2.4/5.5	2.9/6.2
34'	Simple	–	–	–	63	95	136	187	249	322	407	506	620
	Multiple	–	–	–	89	132	187	255	317	371	430	492	559
	Min. Bearing	–	–	–	1.5/3	1.5/3	1.5/3	1.5/3	1.5/3.4	1.5/3.9	1.7/4.5	2.1/5.1	2.6/5.8
36'	Simple	–	–	–	–	77	111	153	205	266	338	421	516
	Multiple	–	–	–	–	108	154	210	278	325	377	432	491
	Min. Bearing	–	–	–	–	1.5/3	1.5/3	1.5/3	1.5/3.1	1.5/3.7	1.5/4.2	1.9/4.8	2.3/5.4
38'	Simple	–	–	–	–	62	91	126	170	221	282	352	433
	Multiple	–	–	–	–	88	127	175	233	287	333	382	434
	Min. Bearing	–	–	–	–	1.5/3	1.5/3	1.5/3	1.5/3	1.5/3.5	1.5/4	1.7/4.5	2/5.1
40'	Simple	–	–	–	–	–	74	105	141	185	237	297	366
	Multiple	–	–	–	–	–	105	146	195	254	295	339	386
	Min. Bearing	–	–	–	–	–	1.5/3	1.5/3	1.5/3	1.5/3.3	1.5/3.8	1.5/4.3	1.8/4.8

NOTES

- ▶ Both Architectural and Framing appearance classification BOISE GLULAM® beams have the same structural classification, 24F-V4. Appearance classification does not affect the beam's allowable design values.
- ▶ Uniform PLF load values are limited by shear, moment, total load deflection limited to L/240 and live load deflection limited to L/360.
- ▶ Live load is equal to 0.8 of total load (residential loading).
- ▶ Table values assume that lateral support is provided at each support and continuously along the compression edge of the beam.
- ▶ Span is measured center to center of the supports.
- ▶ Table values for Minimum Required Bearing Lengths are based on the allowable compression design value perpendicular to grain for the beam and the load value shown. Other design considerations, such as a weaker support material, may warrant longer bearing lengths. Table values assume that support is provided across the full width of the beam.
- ▶ Table assumes dry-use conditions.
- ▶ Table was designed to apply to a broad range of applications. It may be possible to exceed the limitations of this table by analyzing a specific application with the BC Calc® software.

BOISE GLULAM Beams Floor Load Tables

Architectural Appearance Beams — 8¾"

24F-V4 Grade — 100% Load Duration

In pounds per lineal foot (PLF)

Span	Span Type	9"	10.5"	12"	13.5"	15"	16.5"	18"	19.5"	21"	22.5"	24"
6'	Simple	5,231	7,124	9,249	11,101	13,218	15,661	18,512	21,881	25,925	30,869	37,049
	Multiple	4,028	5,486	6,720	7,921	9,243	10,704	12,328	14,144	16,187	18,502	21,149
	Min. Bearing	2.8/5.3	3.8/7.3	4.9/8.9	5.9/10.5	7/12.2	8.3/14.2	9.8/16.3	11.6/18.7	13.7/21.4	16.3/24.5	19.6/28
8'	Simple	2,934	3,997	5,224	6,616	8,171	9,682	11,092	12,651	14,383	16,320	18,499
	Multiple	2,257	3,076	4,021	5,093	6,151	7,001	7,912	8,890	9,944	11,082	12,316
	Min. Bearing	2.1/4	2.8/5.4	3.7/7.1	4.7/9	5.8/10.9	6.8/12.4	7.8/14	8.9/15.7	10.1/17.6	11.5/19.6	13/21.7
10'	Simple	1,753	2,550	3,334	4,224	5,210	6,247	7,373	8,587	9,889	11,082	12,316
	Multiple	1,438	1,961	2,564	3,249	4,008	4,807	5,675	6,476	7,169	7,902	8,678
	Min. Bearing	1.6/3.2	2.3/4.4	3/5.7	3.7/7.2	4.6/8.9	5.5/10.6	6.5/12.6	7.6/14.3	8.7/15.9	9.8/17.5	10.9/19.2
12'	Simple	1,006	1,606	2,308	2,897	3,542	4,249	5,016	5,842	6,729	7,675	8,679
	Multiple	993	1,355	1,773	2,227	2,723	3,267	3,857	4,494	5,177	5,905	6,678
	Min. Bearing	1.5/3	1.7/3.6	2.5/4.7	3.1/5.9	3.8/7.3	4.5/8.7	5.3/10.3	6.2/12	7.1/13.8	8.1/15.7	9.2/17.7
14'	Simple	627	1,003	1,505	2,088	2,554	3,064	3,618	4,215	4,856	5,539	6,265
	Multiple	724	989	1,279	1,603	1,961	2,354	2,780	3,240	3,733	4,259	4,817
	Min. Bearing	1.5/3	1.5/3.1	1.9/4	2.6/5	3.2/6.1	3.8/7.4	4.5/8.7	5.2/10.1	6/11.6	6.9/13.3	7.8/15
16'	Simple	413	665	1,000	1,431	1,922	2,306	2,724	3,174	3,657	4,173	4,720
	Multiple	550	742	960	1,204	1,474	1,770	2,091	2,437	2,809	3,206	3,627
	Min. Bearing	1.5/3	1.5/3	1.5/3.5	2.1/4.3	2.7/5.3	3.3/6.3	3.9/7.5	4.5/8.7	5.2/10	5.9/11.4	6.7/12.9
18'	Simple	285	460	695	997	1,375	1,793	2,119	2,470	2,846	3,248	3,675
	Multiple	380	575	744	934	1,144	1,374	1,624	1,894	2,184	2,493	2,821
	Min. Bearing	1.5/3	1.5/3	1.5/3	1.6/3.8	2.2/4.7	2.9/5.6	3.4/6.6	4/7.7	4.6/8.8	5.2/10.1	5.9/11.4
20'	Simple	202	329	499	719	993	1,330	1,691	1,971	2,272	2,594	2,935
	Multiple	272	440	591	743	911	1,094	1,294	1,510	1,741	1,988	2,251
	Min. Bearing	1.5/3	1.5/3	1.5/3	1.5/3.4	1.8/4.1	2.4/5	3/5.9	3.5/6.8	4.1/7.9	4.6/9	5.3/10.1
22'	Simple	147	242	369	533	738	990	1,293	1,606	1,852	2,115	2,394
	Multiple	200	325	479	603	740	890	1,053	1,229	1,417	1,619	1,833
	Min. Bearing	1.5/3	1.5/3	1.5/3	1.5/3.1	1.5/3.7	2/4.5	2.6/5.3	3.2/6.1	3.7/7.1	4.2/8.1	4.7/9.1
24'	Simple	109	181	278	404	561	755	987	1,262	1,535	1,753	1,985
	Multiple	149	245	374	497	611	735	870	1,016	1,173	1,341	1,519
	Min. Bearing	1.5/3	1.5/3	1.5/3	1.5/3	1.5/3.4	1.7/4.1	2.2/4.8	2.8/5.6	3.3/6.4	3.8/7.3	4.3/8.3
26'	Simple	82	138	213	312	435	586	768	984	1,236	1,475	1,670
	Multiple	113	188	289	416	511	616	730	853	985	1,126	1,276
	Min. Bearing	1.5/3	1.5/3	1.5/3	1.5/3	1.5/3.1	1.5/3.7	1.8/4.4	2.3/5.1	2.9/5.9	3.5/6.7	3.9/7.6
28'	Simple	62	106	166	244	342	462	607	780	981	1,213	1,422
	Multiple	87	146	226	330	433	522	619	724	836	957	1,085
	Min. Bearing	1.5/3	1.5/3	1.5/3	1.5/3	1.5/3	1.5/3.4	1.6/4	2/4.7	2.5/5.4	3.1/6.2	3.6/7
30'	Simple	–	82	130	193	272	369	487	626	789	978	1,193
	Multiple	–	115	179	263	368	447	530	621	718	821	931
	Min. Bearing	–	1.5/3	1.5/3	1.5/3	1.5/3	1.5/3.2	1.5/3.7	1.8/4.4	2.2/5	2.7/5.7	3.3/6.5
32'	Simple	–	64	103	154	218	298	394	509	642	797	974
	Multiple	–	91	143	211	297	386	458	537	621	711	807
	Min. Bearing	–	1.5/3	1.5/3	1.5/3	1.5/3	1.5/3	1.5/3.5	1.5/4.1	1.9/4.7	2.4/5.3	2.9/6
34'	Simple	–	–	81	123	177	243	322	417	528	657	804
	Multiple	–	–	115	171	243	330	399	468	541	620	704
	Min. Bearing	–	–	1.5/3	1.5/3	1.5/3	1.5/3	1.5/3.3	1.5/3.8	1.7/4.4	2.1/5	2.6/5.6
36'	Simple	–	–	64	99	144	199	266	345	438	546	669
	Multiple	–	–	93	140	199	273	350	410	475	545	619
	Min. Bearing	–	–	1.5/3	1.5/3	1.5/3	1.5/3	1.5/3.1	1.5/3.6	1.5/4.1	1.9/4.7	2.3/5.3
38'	Simple	–	–	51	80	118	164	220	287	366	457	561
	Multiple	–	–	75	115	165	227	301	362	419	481	547
	Min. Bearing	–	–	1.5/3	1.5/3	1.5/3	1.5/3	1.5/3	1.5/3.4	1.5/3.9	1.7/4.4	2/5
40'	Simple	–	–	–	65	96	136	183	240	307	385	474
	Multiple	–	–	–	94	137	189	253	320	372	427	486
	Min. Bearing	–	–	–	1.5/3	1.5/3	1.5/3	1.5/3	1.5/3.2	1.5/3.7	1.5/4.2	1.8/4.7

NOTES

- ▶ Both Architectural and Framing appearance classification BOISE GLULAM® beams have the same structural classification, 24F-V4. Appearance classification does not affect the beam's allowable design values.
- ▶ Uniform PLF load values are limited by shear, moment, total load deflection limited to L/240 and live load deflection limited to L/360.
- ▶ Live load is equal to 0.8 of total load (residential loading).
- ▶ Table values assume that lateral support is provided at each support and continuously along the compression edge of the beam.
- ▶ Span is measured center to center of the supports.
- ▶ Table values for Minimum Required Bearing Lengths are based on the allowable compression design value perpendicular to grain for the beam and the load value shown. Other design considerations, such as a weaker support material, may warrant longer bearing lengths. Table values assume that support is provided across the full width of the beam.
- ▶ Table assumes dry-use conditions.
- ▶ Table was designed to apply to a broad range of applications. It may be possible to exceed the limitations of this table by analyzing a specific application with the BC Calc® software.

BOISE GLULAM Beams Roof Load Tables

Architectural Appearance Beams — 3 1/8"

24F-V4 Grade — 115% Snow Load

In pounds per lineal foot (PLF)

Span	Span Type	6"	7.5"	9"	10.5"	12"	13.5"	15"	16.5"	18"
6'	Simple	954	1,492	2,149	2,927	3,800	4,561	5,431	6,434	7,605
	Multiple	734	1,149	1,655	2,254	2,761	3,255	3,798	4,398	5,065
	Min. Bearing	1.5/3	2.2/4.3	3.2/6.1	4.3/8.4	5.6/10.2	6.8/12.1	8/14.1	9.5/16.3	11.3/18.8
8'	Simple	535	837	1,206	1,643	2,147	2,719	3,358	3,978	4,558
	Multiple	411	644	928	1,265	1,653	2,093	2,528	2,877	3,252
	Min. Bearing	1.5/3	1.7/3.2	2.4/4.6	3.3/6.3	4.2/8.2	5.4/10.4	6.6/12.5	7.9/14.2	9/16.1
10'	Simple	295	533	769	1,049	1,371	1,736	2,145	2,597	3,091
	Multiple	261	410	592	806	1,055	1,336	1,651	1,999	2,380
	Min. Bearing	1.5/3	1.5/3	1.9/3.7	2.6/5	3.4/6.5	4.3/8.3	5.3/10.2	6.4/12.4	7.6/14.7
12'	Simple	169	333	532	726	949	1,203	1,486	1,799	2,143
	Multiple	180	283	409	558	730	925	1,143	1,384	1,648
	Min. Bearing	1.5/3	1.5/3	1.6/3.1	2.2/4.2	2.8/5.5	3.6/6.9	4.4/8.5	5.4/10.3	6.4/12.3
14'	Simple	105	208	362	531	695	881	1,089	1,319	1,571
	Multiple	131	206	298	408	534	677	837	1,014	1,207
	Min. Bearing	1.5/3	1.5/3	1.5/3	1.9/3.6	2.4/4.7	3.1/5.9	3.8/7.3	4.6/8.8	5.5/10.5
16'	Simple	69	137	240	385	530	672	831	1,007	1,199
	Multiple	92	157	227	310	406	516	638	773	921
	Min. Bearing	1.5/3	1.5/3	1.5/3	1.5/3.1	2.1/4.1	2.7/5.2	3.3/6.4	4/7.7	4.8/9.2
18'	Simple	47	95	167	268	402	529	654	793	945
	Multiple	63	123	178	243	319	405	502	608	725
	Min. Bearing	1.5/3	1.5/3	1.5/3	1.5/3	1.8/3.6	2.4/4.6	2.9/5.7	3.6/6.9	4.2/8.2
20'	Simple	–	68	120	193	291	417	528	640	763
	Multiple	–	91	143	196	257	326	404	490	585
	Min. Bearing	–	1.5/3	1.5/3	1.5/3	1.5/3.3	2.1/4.1	2.7/5.1	3.2/6.2	3.8/7.4
22'	Simple	–	49	88	143	216	311	429	527	628
	Multiple	–	67	117	160	211	268	332	403	481
	Min. Bearing	–	1.5/3	1.5/3	1.5/3	1.5/3	1.7/3.8	2.4/4.6	2.9/5.6	3.5/6.7
24'	Simple	–	–	66	108	164	237	328	439	523
	Multiple	–	–	89	133	176	223	277	337	400
	Min. Bearing	–	–	1.5/3	1.5/3	1.5/3	1.5/3.5	2/4.3	2.7/5.2	3.2/6.1
26'	Simple	–	–	51	84	127	184	255	342	440
	Multiple	–	–	69	112	148	189	234	284	336
	Min. Bearing	–	–	1.5/3	1.5/3	1.5/3	1.5/3.2	1.7/3.9	2.3/4.7	2.9/5.6
28'	Simple	–	–	–	65	100	145	202	272	355
	Multiple	–	–	–	88	127	161	200	241	286
	Min. Bearing	–	–	–	1.5/3	1.5/3	1.5/3	1.5/3.6	2/4.4	2.5/5.2
30'	Simple	–	–	–	52	80	116	162	219	286
	Multiple	–	–	–	70	108	139	172	207	245
	Min. Bearing	–	–	–	1.5/3	1.5/3	1.5/3	1.5/3.4	1.7/4.1	2.2/4.8
32'	Simple	–	–	–	–	64	94	132	178	234
	Multiple	–	–	–	–	87	121	149	179	212
	Min. Bearing	–	–	–	–	1.5/3	1.5/3	1.5/3.1	1.5/3.8	1.9/4.5
34'	Simple	–	–	–	–	52	77	108	146	192
	Multiple	–	–	–	–	71	104	129	156	185
	Min. Bearing	–	–	–	–	1.5/3	1.5/3	1.5/3	1.5/3.5	1.7/4.2
36'	Simple	–	–	–	–	–	63	89	121	160
	Multiple	–	–	–	–	–	86	113	137	163
	Min. Bearing	–	–	–	–	–	1.5/3	1.5/3	1.5/3.3	1.5/3.9
38'	Simple	–	–	–	–	–	52	74	101	134
	Multiple	–	–	–	–	–	72	100	121	144
	Min. Bearing	–	–	–	–	–	1.5/3	1.5/3	1.5/3.1	1.5/3.7
40'	Simple	–	–	–	–	–	–	62	85	113
	Multiple	–	–	–	–	–	–	85	107	128
	Min. Bearing	–	–	–	–	–	–	1.5/3	1.5/3	1.5/3.5

NOTES

- ▶ Both Architectural and Framing appearance classification BOISE GLULAM® beams have the same structural classification, 24F-V4. Appearance classification does not affect the beam's allowable design values.
- ▶ Uniform PLF load values are limited by shear, moment, total load deflection limited to L/240 and live load deflection limited to L/360.
- ▶ Live load is equal to 0.8 of total load (residential loading).
- ▶ Table values assume that lateral support is provided at each support and continuously along the compression edge of the beam.
- ▶ Span is measured center to center of the supports.
- ▶ Table values for Minimum Required Bearing Lengths are based on the allowable compression design value perpendicular to grain for the beam and the load value shown. Other design considerations, such as a weaker support material, may warrant longer bearing lengths. Table values assume that support is provided across the full width of the beam.
- ▶ Wind loading has not been considered in this table.
- ▶ Table assumes dry-use conditions.
- ▶ Table was designed to apply to a broad range of applications. It may be possible to exceed the limitations of this table by analyzing a specific application with the BC Calc® software.

BOISE GLULAM Beams Roof Load Tables

Architectural Appearance Beams — 3½"

24F-V4 Grade — 115% Snow Load

In pounds per lineal foot (PLF)

Span	Span Type	6"	7.5"	9"	10.5"	12"	13.5"	15"	16.5"	18"
6'	Simple	1,068	1,671	2,407	3,278	4,256	5,108	6,082	7,206	8,518
	Multiple	822	1,286	1,854	2,525	3,093	3,646	4,254	4,926	5,673
	Min. Bearing	1.5 / 3	2.2 / 4.3	3.2 / 6.1	4.3 / 8.4	5.6 / 10.2	6.8 / 12.1	8 / 14.1	9.5 / 16.3	11.3 / 18.8
8'	Simple	599	937	1,351	1,840	2,405	3,045	3,761	4,456	5,104
	Multiple	460	721	1,039	1,416	1,851	2,345	2,832	3,223	3,642
	Min. Bearing	1.5 / 3	1.7 / 3.2	2.4 / 4.6	3.3 / 6.3	4.2 / 8.2	5.4 / 10.4	6.6 / 12.5	7.9 / 14.2	9 / 16.1
10'	Simple	331	597	862	1,174	1,535	1,945	2,402	2,908	3,462
	Multiple	293	459	663	903	1,181	1,496	1,849	2,238	2,665
	Min. Bearing	1.5 / 3	1.5 / 3	1.9 / 3.7	2.6 / 5	3.4 / 6.5	4.3 / 8.3	5.3 / 10.2	6.4 / 12.4	7.6 / 14.7
12'	Simple	189	373	596	813	1,063	1,347	1,664	2,015	2,400
	Multiple	202	317	458	625	817	1,036	1,280	1,550	1,846
	Min. Bearing	1.5 / 3	1.5 / 3	1.6 / 3.1	2.2 / 4.2	2.8 / 5.5	3.6 / 6.9	4.4 / 8.5	5.4 / 10.3	6.4 / 12.3
14'	Simple	117	233	406	595	778	987	1,219	1,477	1,759
	Multiple	147	231	334	456	598	758	937	1,135	1,352
	Min. Bearing	1.5 / 3	1.5 / 3	1.5 / 3	1.9 / 3.6	2.4 / 4.7	3.1 / 5.9	3.8 / 7.3	4.6 / 8.8	5.5 / 10.5
16'	Simple	77	154	269	431	594	753	931	1,127	1,343
	Multiple	108	175	254	347	455	578	714	866	1,032
	Min. Bearing	1.5 / 3	1.5 / 3	1.5 / 3	1.5 / 3.1	2.1 / 4.1	2.7 / 5.2	3.3 / 6.4	4 / 7.7	4.8 / 9.2
18'	Simple	53	106	187	300	451	592	733	888	1,058
	Multiple	76	137	199	273	358	454	562	681	812
	Min. Bearing	1.5 / 3	1.5 / 3	1.5 / 3	1.5 / 3	1.8 / 3.6	2.4 / 4.6	2.9 / 5.7	3.6 / 6.9	4.2 / 8.2
20'	Simple	–	76	134	216	326	467	591	717	854
	Multiple	–	108	160	219	288	365	453	549	655
	Min. Bearing	–	1.5 / 3	1.5 / 3	1.5 / 3	1.5 / 3.3	2.1 / 4.1	2.7 / 5.1	3.2 / 6.2	3.8 / 7.4
22'	Simple	–	55	99	160	242	348	480	590	698
	Multiple	–	81	131	180	236	300	372	451	535
	Min. Bearing	–	1.5 / 3	1.5 / 3	1.5 / 3	1.5 / 3	1.7 / 3.8	2.4 / 4.6	2.9 / 5.6	3.4 / 6.6
24'	Simple	–	–	74	121	184	265	367	490	579
	Multiple	–	–	108	149	197	250	310	374	443
	Min. Bearing	–	–	1.5 / 3	1.5 / 3	1.5 / 3	1.5 / 3.5	2 / 4.3	2.7 / 5.1	3.1 / 6
26'	Simple	–	–	57	94	143	206	286	384	487
	Multiple	–	–	84	126	166	212	261	314	372
	Min. Bearing	–	–	1.5 / 3	1.5 / 3	1.5 / 3	1.5 / 3.2	1.7 / 3.9	2.3 / 4.7	2.9 / 5.5
28'	Simple	–	–	–	73	112	163	226	304	398
	Multiple	–	–	–	107	142	180	222	267	316
	Min. Bearing	–	–	–	1.5 / 3	1.5 / 3	1.5 / 3	1.5 / 3.6	2 / 4.3	2.5 / 5.1
30'	Simple	–	–	–	58	89	130	182	245	321
	Multiple	–	–	–	86	122	155	190	229	271
	Min. Bearing	–	–	–	1.5 / 3	1.5 / 3	1.5 / 3	1.5 / 3.3	1.7 / 4	2.2 / 4.7
32'	Simple	–	–	–	–	72	105	147	199	262
	Multiple	–	–	–	–	106	133	164	198	235
	Min. Bearing	–	–	–	–	1.5 / 3	1.5 / 3	1.5 / 3.1	1.5 / 3.7	1.9 / 4.4
34'	Simple	–	–	–	–	58	86	121	164	216
	Multiple	–	–	–	–	87	116	143	173	205
	Min. Bearing	–	–	–	–	1.5 / 3	1.5 / 3	1.5 / 3	1.5 / 3.5	1.7 / 4.1
36'	Simple	–	–	–	–	–	71	100	136	179
	Multiple	–	–	–	–	–	102	126	152	180
	Min. Bearing	–	–	–	–	–	1.5 / 3	1.5 / 3	1.5 / 3.3	1.5 / 3.9
38'	Simple	–	–	–	–	–	58	83	113	150
	Multiple	–	–	–	–	–	88	111	134	159
	Min. Bearing	–	–	–	–	–	1.5 / 3	1.5 / 3	1.5 / 3.1	1.5 / 3.6
40'	Simple	–	–	–	–	–	–	69	95	126
	Multiple	–	–	–	–	–	–	98	119	141
	Min. Bearing	–	–	–	–	–	–	1.5 / 3	1.5 / 3	1.5 / 3.4

NOTES

- ▶ Both Architectural and Framing appearance classification BOISE GLULAM® beams have the same structural classification, 24F-V4. Appearance classification does not affect the beam's allowable design values.
- ▶ Uniform PLF load values are limited by shear, moment, total load deflection limited to L/240 and live load deflection limited to L/360.
- ▶ Live load is equal to 0.8 of total load (residential loading).
- ▶ Table values assume that lateral support is provided at each support and continuously along the compression edge of the beam.
- ▶ Span is measured center to center of the supports.
- ▶ Table values for Minimum Required Bearing Lengths are based on the allowable compression design value perpendicular to grain for the beam and the load value shown. Other design considerations, such as a weaker support material, may warrant longer bearing lengths. Table values assume that support is provided across the full width of the beam.
- ▶ Wind loading has not been considered in this table.
- ▶ Table assumes dry-use conditions.
- ▶ Table was designed to apply to a broad range of applications. It may be possible to exceed the limitations of this table by analyzing a specific application with the BC Calc® software.

BOISE GLULAM Beams Roof Load Tables

Architectural Appearance Beams — 5 1/8"

24F-V4 Grade — 115% Snow Load

In pounds per lineal foot (PLF)

Span	Span Type	6"	7.5"	9"	10.5"	12"	13.5"	15"	16.5"	18"	19.5"	21"	22.5"	24"
6'	Simple	1,564	2,446	3,525	4,800	6,232	7,480	8,906	10,552	12,472				
	Multiple	1,204	1,884	2,715	36.97	4,529	5,338	6,229	7,213	8,307				
	Min. Bearing	1.5/3	2.2/4.3	3.2/6.1	4.3/8.4	5.6/10.2	6.8/12.1	8/14.1	9.5/16.3	11.3/18.8				
8'	Simple	877	1,372	1,978	2,694	3,521	4,459	5,507	6,524	7,474	8,525	9,692		
	Multiple	674	1,055	1,522	2,074	2,711	3,433	4,146	4,719	5,332	5,992	6,702		
	Min. Bearing	1.5/3	1.7/3.2	2.4/4.6	3.3/6.3	4.2/8.2	5.4/10.4	6.6/12.5	7.9/14.2	9/16.1	10.3/18.1	11.7/20.2		
10'	Simple	485	875	1,262	1,720	2,248	2,848	3,518	4,258	5,070	5,952	6,702	7,469	
	Multiple	429	672	970	1,323	1,730	2,191	2,707	3,278	3,903	4,366	4,833	5,327	
	Min. Bearing	1.5/3	1.5/3	1.9/3.7	2.6/5	3.4/6.5	4.3/8.3	5.3/10.2	6.4/12.4	7.6/14.7	9/16.5	10.1/18.2	11.3/20.1	
12'	Simple	277	547	873	1,190	1,557	1,972	2,437	2,951	3,514	4,126	4,787	5,459	6,173
	Multiple	295	464	670	914	1,197	1,516	1,874	2,270	2,703	3,175	3,684	4,137	4,514
	Min. Bearing	1.5/3	1.5/3	1.6/3.1	2.2/4.2	2.8/5.5	3.6/6.9	4.4/8.5	5.4/10.3	6.4/12.3	7.5/14.4	8.7/16.7	9.9/18.8	11.2/20.5
14'	Simple	172	341	594	871	1,140	1,445	1,786	2,163	2,576	3,001	3,456	3,942	4,458
	Multiple	215	338	489	668	875	1,110	1,372	1,662	1,980	2,307	2,658	3,032	3,429
	Min. Bearing	1.5/3	1.5/3	1.5/3	1.9/3.6	2.4/4.7	3.1/5.9	3.8/7.3	4.6/8.8	5.5/10.5	6.4/12.2	7.3/14.1	8.3/16.1	9.4/18.2
16'	Simple	113	225	394	631	869	1,102	1,363	1,643	1,940	2,261	2,605	2,971	3,360
	Multiple	151	257	372	509	667	846	1,046	1,262	1,491	1,737	2,002	2,284	2,584
	Min. Bearing	1.5/3	1.5/3	1.5/3	1.5/3.1	2.1/4.1	2.7/5.2	3.3/6.4	4/7.7	4.7/9.1	5.5/10.6	6.3/12.2	7.2/13.9	8.1/15.7
18'	Simple	77	155	274	439	660	867	1,065	1,279	1,510	1,760	2,028	2,314	2,618
	Multiple	103	201	292	399	523	665	817	981	1,159	1,351	1,557	1,777	2,011
	Min. Bearing	1.5/3	1.5/3	1.5/3	1.5/3	1.8/3.6	2.4/4.6	2.9/5.6	3.5/6.8	4.1/8	4.8/9.3	5.5/10.7	6.3/12.2	7.2/13.8
20'	Simple	54	111	196	317	477	684	850	1,021	1,206	1,406	1,620	1,849	2,092
	Multiple	73	149	234	321	421	531	651	782	925	1,078	1,243	1,419	1,606
	Min. Bearing	1.5/3	1.5/3	1.5/3	1.5/3	1.5/3.3	2.1/4.1	2.6/5	3.1/6	3.7/7.1	4.3/8.3	4.9/9.5	5.6/10.9	6.4/12.3
22'	Simple	—	81	145	235	355	509	693	832	983	1,146	1,322	1,509	1,707
	Multiple	—	109	192	263	344	432	530	636	753	878	1,013	1,156	1,309
	Min. Bearing	—	1.5/3	1.5/3	1.5/3	1.5/3	1.7/3.7	2.3/4.5	2.8/5.4	3.3/6.4	3.9/7.5	4.5/8.6	5.1/9.8	5.7/11.1
24'	Simple	—	60	109	178	270	389	537	689	815	951	1,097	1,252	1,417
	Multiple	—	82	147	219	284	357	438	527	623	727	839	959	1,085
	Min. Bearing	—	1.5/3	1.5/3	1.5/3	1.5/3	1.5/3.4	2/4.1	2.6/4.9	3/5.8	3.5/6.8	4/7.8	4.6/8.9	5.2/10
26'	Simple	—	45	83	137	209	302	419	562	686	800	923	1,054	1,193
	Multiple	—	63	113	183	238	299	367	442	523	611	705	806	913
	Min. Bearing	—	1.5/3	1.5/3	1.5/3	1.5/3	1.5/3.1	1.7/3.8	2.3/4.5	2.8/5.3	3.2/6.2	3.7/7.1	4.2/8.1	4.8/9.2
28'	Simple	—	—	64	107	164	238	332	446	583	681	786	898	1,017
	Multiple	—	—	88	145	201	254	312	375	445	520	600	686	777
	Min. Bearing	—	—	1.5/3	1.5/3	1.5/3	1.5/3	1.5/3.5	2/4.2	2.5/4.9	3/5.7	3.4/6.6	3.9/7.5	4.4/8.5
30'	Simple	—	—	50	85	131	191	266	358	470	586	677	773	876
	Multiple	—	—	70	115	172	217	267	322	382	446	515	589	668
	Min. Bearing	—	—	1.5/3	1.5/3	1.5/3	1.5/3	1.5/3.2	1.7/3.9	2.2/4.5	2.7/5.3	3.2/6.1	3.6/7	4.1/7.9
32'	Simple	—	—	—	67	105	154	216	292	383	491	587	672	761
	Multiple	—	—	—	93	143	187	231	279	330	387	447	511	580
	Min. Bearing	—	—	—	1.5/3	1.5/3	1.5/3	1.5/3	1.5/3.6	1.9/4.2	2.5/4.9	2.9/5.7	3.4/6.5	3.8/7.3
34'	Simple	—	—	—	54	85	126	177	240	316	405	511	588	666
	Multiple	—	—	—	75	117	163	201	243	288	337	390	447	507
	Min. Bearing	—	—	—	1.5/3	1.5/3	1.5/3	1.5/3	1.5/3.4	1.7/4	2.2/4.6	2.7/5.3	3.1/6.1	3.6/6.8
36'	Simple	—	—	—	—	69	103	146	199	262	338	426	518	588
	Multiple	—	—	—	—	96	141	176	213	253	297	343	393	446
	Min. Bearing	—	—	—	—	1.5/3	1.5/3	1.5/3	1.5/3.2	1.5/3.7	2/4.3	2.4/5	3/5.7	3.3/6.4
38'	Simple	—	—	—	—	57	85	121	166	220	284	358	445	521
	Multiple	—	—	—	—	79	118	155	188	224	262	304	348	395
	Min. Bearing	—	—	—	—	1.5/3	1.5/3	1.5/3	1.5/3	1.5/3.5	1.8/4.1	2.2/4.7	2.7/5.4	3.1/6.1
40'	Simple	—	—	—	—	47	71	101	139	185	240	303	377	462
	Multiple	—	—	—	—	66	98	138	167	198	233	270	309	352
	Min. Bearing	—	—	—	—	1.5/3	1.5/3	1.5/3	1.5/3	1.5/3.3	1.6/3.9	2/4.4	2.4/5.1	3/5.7

NOTES

- ▶ Both Architectural and Framing appearance classification BOISE GLULAM® beams have the same structural classification, 24F-V4. Appearance classification does not affect the beam's allowable design values.
- ▶ Uniform PLF load values are limited by shear, moment, total load deflection limited to L/240 and live load deflection limited to L/360.
- ▶ Live load is equal to 0.8 of total load (residential loading).
- ▶ Table values assume that lateral support is provided at each support and continuously along the compression edge of the beam.
- ▶ Span is measured center to center of the supports.
- ▶ Table values for Minimum Required Bearing Lengths are based on the allowable compression design value perpendicular to grain for the beam and the load value shown. Other design considerations, such as a weaker support material, may warrant longer bearing lengths. Table values assume that support is provided across the full width of the beam.
- ▶ Wind loading has not been considered in this table.
- ▶ Table assumes dry-use conditions.
- ▶ Table was designed to apply to a broad range of applications. It may be possible to exceed the limitations of this table by analyzing a specific application with the BC Calc® software.

BOISE GLULAM Beams Roof Load Tables

Architectural Appearance Beams — 5½"

24F-V4 Grade — 115% Snow Load

In pounds per lineal foot (PLF)

Span	Span Type	6"	7.5"	9"	10.5"	12"	13.5"	15"	16.5"	18"	19.5"	21"	22.5"	24"
6'	Simple	1,679	2,625	3,783	5,151	6,688	8,027	9,558	11,324	13,385	15,821	18,745	22,318	26,786
	Multiple	1,292	2,021	2,913	3,968	4,860	5,729	6,684	7,741	8,915	10,228	11,705	13,379	14,268
	Min. Bearing	1.5 / 3	2.2 / 4.3	3.2 / 6.1	4.3 / 8.4	5.6 / 10.2	6.8 / 12.1	8 / 14.1	9.5 / 16.3	11.3 / 18.8	13.3 / 21.5	15.8 / 24.6	18.8 / 28.1	22.5 / 30
8'	Simple	941	1,472	2,123	2,892	3,779	4,785	5,910	7,002	8,021	9,149	10,401	11,801	13,377
	Multiple	723	1,133	1,633	2,226	2,909	3,684	4,450	5,064	5,723	6,430	7,192	8,015	8,907
	Min. Bearing	1.5 / 3	1.7 / 3.2	2.4 / 4.6	3.3 / 6.3	4.2 / 8.2	5.4 / 10.4	6.6 / 12.5	7.9 / 14.2	9 / 16.1	10.3 / 18.1	11.7 / 20.2	13.2 / 22.5	15 / 25
10'	Simple	520	939	1,354	1,846	2,413	3,056	3,775	4,570	5,441	6,387	7,192	8,015	8,907
	Multiple	460	721	1,041	1,419	1,856	2,351	2,905	3,518	4,188	4,685	5,187	5,717	6,278
	Min. Bearing	1.5 / 3	1.5 / 3	1.9 / 3.7	2.6 / 5	3.4 / 6.5	4.3 / 8.3	5.3 / 10.2	6.4 / 12.4	7.6 / 14.7	9 / 16.5	10.1 / 18.2	11.3 / 20.1	12.5 / 22.1
12'	Simple	298	587	937	1,277	1,671	2,117	2,615	3,167	3,771	4,428	5,101	5,817	6,578
	Multiple	317	498	719	981	1,284	1,627	2,011	2,436	2,901	3,407	3,926	4,440	4,844
	Min. Bearing	1.5 / 3	1.5 / 3	1.6 / 3.1	2.2 / 4.2	2.8 / 5.5	3.6 / 6.9	4.4 / 8.5	5.4 / 10.3	6.4 / 12.3	7.5 / 14.4	8.6 / 16.6	9.8 / 18.8	11.1 / 20.5
14'	Simple	184	366	637	935	1,223	1,550	1,916	2,321	2,744	3,197	3,683	4,200	4,750
	Multiple	231	363	525	717	939	1,191	1,472	1,784	2,110	2,459	2,832	3,231	3,654
	Min. Bearing	1.5 / 3	1.5 / 3	1.5 / 3	1.9 / 3.6	2.4 / 4.7	3.1 / 5.9	3.8 / 7.3	4.6 / 8.8	5.4 / 10.4	6.3 / 12.2	7.3 / 14	8.3 / 16	9.4 / 18
16'	Simple	121	242	423	677	933	1,183	1,459	1,751	2,067	2,409	2,775	3,166	3,581
	Multiple	170	276	399	546	715	908	1,120	1,345	1,588	1,851	2,133	2,433	2,753
	Min. Bearing	1.5 / 3	1.5 / 3	1.5 / 3	1.5 / 3.1	2.1 / 4.1	2.7 / 5.2	3.3 / 6.4	4 / 7.6	4.7 / 9	5.4 / 10.5	6.3 / 12.1	7.2 / 13.8	8.1 / 15.6
18'	Simple	83	167	294	471	708	927	1,135	1,362	1,609	1,875	2,161	2,466	2,789
	Multiple	119	216	313	428	562	711	870	1,045	1,235	1,440	1,659	1,894	2,143
	Min. Bearing	1.5 / 3	1.5 / 3	1.5 / 3	1.5 / 3	1.8 / 3.6	2.4 / 4.6	2.9 / 5.6	3.5 / 6.7	4.1 / 7.9	4.8 / 9.2	5.5 / 10.6	6.3 / 12.1	7.1 / 13.7
20'	Simple	58	119	211	340	512	734	906	1,088	1,285	1,498	1,726	1,970	2,229
	Multiple	86	170	251	344	451	566	694	833	985	1,149	1,324	1,512	1,711
	Min. Bearing	1.5 / 3	1.5 / 3	1.5 / 3	1.5 / 3	1.5 / 3.3	2.1 / 4.1	2.6 / 5	3.1 / 6	3.7 / 7.1	4.3 / 8.2	4.9 / 9.5	5.6 / 10.8	6.3 / 12.2
22'	Simple	–	87	155	252	381	547	738	886	1,048	1,222	1,408	1,607	1,819
	Multiple	–	127	206	282	366	460	564	678	802	936	1,079	1,232	1,395
	Min. Bearing	–	1.5 / 3	1.5 / 3	1.5 / 3	1.5 / 3	1.7 / 3.7	2.3 / 4.5	2.8 / 5.4	3.3 / 6.4	3.8 / 7.4	4.4 / 8.5	5 / 9.7	5.7 / 11
24'	Simple	–	65	117	191	290	417	577	735	869	1,013	1,168	1,334	1,510
	Multiple	–	96	170	233	302	380	467	561	664	775	894	1,021	1,156
	Min. Bearing	–	1.5 / 3	1.5 / 3	1.5 / 3	1.5 / 3	1.5 / 3.3	2 / 4.1	2.5 / 4.9	3 / 5.8	3.5 / 6.7	4 / 7.7	4.6 / 8.8	5.2 / 10
26'	Simple	–	–	89	147	224	324	449	603	730	852	983	1,123	1,271
	Multiple	–	–	132	195	253	319	391	471	558	651	751	859	973
	Min. Bearing	–	–	1.5 / 3	1.5 / 3	1.5 / 3	1.5 / 3.1	1.7 / 3.7	2.3 / 4.5	2.7 / 5.3	3.2 / 6.2	3.7 / 7.1	4.2 / 8.1	4.7 / 9.1
28'	Simple	–	–	69	115	176	256	356	478	622	726	837	957	1,083
	Multiple	–	–	103	165	214	270	332	400	474	553	639	731	828
	Min. Bearing	–	–	1.5 / 3	1.5 / 3	1.5 / 3	1.5 / 3	1.5 / 3.4	2 / 4.1	2.5 / 4.9	2.9 / 5.7	3.4 / 6.5	3.9 / 7.4	4.4 / 8.4
30'	Simple	–	–	54	91	140	205	286	385	504	624	721	824	933
	Multiple	–	–	82	135	183	231	285	343	407	475	549	628	712
	Min. Bearing	–	–	1.5 / 3	1.5 / 3	1.5 / 3	1.5 / 3	1.5 / 3.2	1.7 / 3.8	2.2 / 4.5	2.7 / 5.3	3.1 / 6.1	3.6 / 6.9	4 / 7.8
32'	Simple	–	–	–	72	113	165	232	313	411	527	626	715	811
	Multiple	–	–	–	109	158	200	246	297	352	412	476	545	618
	Min. Bearing	–	–	–	1.5 / 3	1.5 / 3	1.5 / 3	1.5 / 3	1.5 / 3.6	1.9 / 4.2	2.5 / 4.9	2.9 / 5.6	3.3 / 6.4	3.8 / 7.3
34'	Simple	–	–	–	58	91	135	190	257	339	435	548	626	710
	Multiple	–	–	–	88	137	174	214	259	307	359	416	476	540
	Min. Bearing	–	–	–	1.5 / 3	1.5 / 3	1.5 / 3	1.5 / 3	1.5 / 3.3	1.7 / 3.9	2.2 / 4.6	2.7 / 5.3	3.1 / 6	3.5 / 6.8
36'	Simple	–	–	–	–	74	111	157	213	281	362	457	552	626
	Multiple	–	–	–	–	113	152	188	227	270	316	366	419	475
	Min. Bearing	–	–	–	–	1.5 / 3	1.5 / 3	1.5 / 3	1.5 / 3.1	1.5 / 3.7	2 / 4.3	2.4 / 5	2.9 / 5.6	3.3 / 6.4
38'	Simple	–	–	–	–	61	92	130	178	236	304	384	477	555
	Multiple	–	–	–	–	94	134	165	200	238	279	323	370	421
	Min. Bearing	–	–	–	–	1.5 / 3	1.5 / 3	1.5 / 3	1.5 / 3	1.5 / 3.5	1.8 / 4.1	2.2 / 4.7	2.7 / 5.3	3.1 / 6
40'	Simple	–	–	–	–	–	76	109	150	199	257	326	405	495
	Multiple	–	–	–	–	–	116	146	177	211	248	287	330	374
	Min. Bearing	–	–	–	–	–	1.5 / 3	1.5 / 3	1.5 / 3	1.5 / 3.3	1.6 / 3.8	2 / 4.4	2.4 / 5	3 / 5.7

NOTES

- ▶ Both Architectural and Framing appearance classification BOISE GLULAM® beams have the same structural classification, 24F-V4. Appearance classification does not affect the beam's allowable design values.
- ▶ Uniform PLF load values are limited by shear, moment, total load deflection limited to L/240 and live load deflection limited to L/360.
- ▶ Live load is equal to 0.8 of total load (residential loading).
- ▶ Table values assume that lateral support is provided at each support and continuously along the compression edge of the beam.
- ▶ Span is measured center to center of the supports.
- ▶ Table values for Minimum Required Bearing Lengths are based on the allowable compression design value perpendicular to grain for the beam and the load value shown. Other design considerations, such as a weaker support material, may warrant longer bearing lengths. Table values assume that support is provided across the full width of the beam.
- ▶ Wind loading has not been considered in this table.
- ▶ Table assumes dry-use conditions.
- ▶ Table was designed to apply to a broad range of applications. It may be possible to exceed the limitations of this table by analyzing a specific application with the BC Calc® software.

BOISE GLULAM Beams Roof Load Tables

Architectural Appearance Beams — 6¾"

24F-V4 Grade — 115% Snow Load

In pounds per lineal foot (PLF)

Span	Span Type	7.5"	9"	10.5"	12"	13.5"	15"	16.5"	18"	19.5"	21"	22.5"	24"
6'	Simple	3,222	4,643	6,322	8,209	9,852	11,730	13,898	16,427				
	Multiple	2,481	3,575	4,869	5,964	7,031	8,204	9,500	10,941				
	Min. Bearing	2.2/4.3	3.2/6.1	4.3/8.4	5.6/10.2	6.8/12.1	8/14.1	9.5/16.3	11.3/18.8				
8'	Simple	1,807	2,605	3,549	4,638	5,872	7,253	8,593	9,844	11,228	12,765		
	Multiple	1,390	2,005	2,731	3,570	4,522	5,461	6,215	7,023	7,892	8,827		
	Min. Bearing	1.7/3.2	2.4/4.6	3.3/6.3	4.2/8.2	5.4/10.4	6.6/12.5	7.9/14.2	9/16.1	10.3/18.1	11.7/20.2		
10'	Simple	1,152	1,662	2,265	2,961	3,750	4,633	5,609	6,677	7,824	8,827	9,837	
	Multiple	885	1,278	1,742	2,278	2,886	3,566	4,317	5,140	5,750	6,365	7,016	
	Min. Bearing	1.5/3	1.9/3.7	2.6/5	3.4/6.5	4.3/8.3	5.3/10.2	6.4/12.4	7.6/14.7	9/16.5	10.1/18.2	11.3/20.1	
12'	Simple	720	1,150	1,568	2,050	2,598	3,210	3,873	4,572	5,325	6,133	6,994	7,909
	Multiple	611	883	1,204	1,576	1,997	2,469	2,979	3,517	4,097	4,719	5,383	5,945
	Min. Bearing	1.5/3	1.6/3.1	2.2/4.2	2.8/5.5	3.6/6.9	4.4/8.5	5.3/10.3	6.3/12.1	7.3/14.1	8.4/16.3	9.6/18.5	10.9/20.5
14'	Simple	449	782	1,147	1,501	1,903	2,330	2,795	3,299	3,844	4,427	5,050	5,711
	Multiple	446	645	880	1,153	1,462	1,790	2,148	2,536	2,955	3,405	3,884	4,393
	Min. Bearing	1.5/3	1.5/3	1.9/3.6	2.4/4.7	3.1/5.9	3.8/7.2	4.5/8.7	5.3/10.2	6.2/11.9	7.1/13.7	8.1/15.6	9.2/17.7
16'	Simple	297	519	831	1,144	1,434	1,754	2,105	2,485	2,896	3,336	3,806	4,305
	Multiple	338	490	670	878	1,100	1,346	1,616	1,909	2,225	2,564	2,925	3,309
	Min. Bearing	1.5/3	1.5/3	1.5/3.1	2.1/4.1	2.7/5.1	3.2/6.2	3.9/7.5	4.6/8.8	5.3/10.3	6.1/11.8	7/13.5	7.9/15.3
18'	Simple	205	360	578	869	1,115	1,364	1,637	1,934	2,254	2,598	2,964	3,353
	Multiple	265	384	526	681	854	1,046	1,256	1,484	1,730	1,994	2,276	2,575
	Min. Bearing	1.5/3	1.5/3	1.5/3	1.8/3.6	2.3/4.5	2.8/5.5	3.4/6.6	4/7.8	4.7/9	5.4/10.4	6.2/11.9	7/13.4
20'	Simple	146	259	417	628	889	1,089	1,307	1,544	1,801	2,075	2,368	2,679
	Multiple	196	308	418	542	680	833	1,001	1,184	1,381	1,592	1,817	2,056
	Min. Bearing	1.5/3	1.5/3	1.5/3	1.5/3.2	2.1/4	2.5/4.9	3/5.9	3.6/6.9	4.2/8	4.8/9.3	5.5/10.6	6.2/11.9
22'	Simple	107	191	309	467	671	887	1,065	1,259	1,468	1,692	1,932	2,186
	Multiple	144	251	339	440	553	678	815	964	1,124	1,297	1,481	1,676
	Min. Bearing	1.5/3	1.5/3	1.5/3	1.5/3	1.7/3.6	2.3/4.4	2.7/5.3	3.2/6.2	3.8/7.2	4.3/8.3	4.9/9.5	5.6/10.8
24'	Simple	79	143	234	355	512	708	883	1,044	1,218	1,404	1,603	1,815
	Multiple	108	193	280	363	457	561	674	798	931	1,074	1,227	1,390
	Min. Bearing	1.5/3	1.5/3	1.5/3	1.5/3	1.5/3.3	2/4	2.5/4.8	2.9/5.7	3.4/6.6	3.9/7.6	4.5/8.6	5.1/9.8
26'	Simple	60	110	180	275	398	551	740	878	1,024	1,182	1,349	1,528
	Multiple	82	149	234	304	383	470	566	670	782	903	1,032	1,169
	Min. Bearing	1.5/3	1.5/3	1.5/3	1.5/3	1.5/3	1.7/3.7	2.3/4.4	2.7/5.2	3.1/6	3.6/6.9	4.1/7.9	4.6/8.9
28'	Simple	45	85	141	216	314	437	587	747	872	1,006	1,150	1,302
	Multiple	64	116	191	257	324	399	480	569	665	768	878	995
	Min. Bearing	1.5/3	1.5/3	1.5/3	1.5/3	1.5/3	1.5/3.4	2/4	2.5/4.8	2.9/5.6	3.3/6.4	3.8/7.3	4.3/8.2
30'	Simple	–	66	111	172	251	350	472	618	750	866	990	1,121
	Multiple	–	92	152	220	278	342	412	488	571	660	754	855
	Min. Bearing	–	1.5/3	1.5/3	1.5/3	1.5/3	1.5/3.1	1.7/3.8	2.2/4.4	2.7/5.2	3.1/5.9	3.5/6.8	4/7.6
32'	Simple	–	52	89	139	203	284	384	504	647	752	859	974
	Multiple	–	73	122	188	240	295	356	423	494	572	654	742
	Min. Bearing	–	1.5/3	1.5/3	1.5/3	1.5/3	1.5/3	1.5/3.5	1.9/4.1	2.5/4.8	2.9/5.5	3.3/6.3	3.7/7.1
34'	Simple	–	–	71	112	166	233	316	416	534	658	752	853
	Multiple	–	–	99	154	208	257	310	369	432	499	571	648
	Min. Bearing	–	–	1.5/3	1.5/3	1.5/3	1.5/3	1.5/3.3	1.7/3.9	2.2/4.5	2.7/5.2	3.1/5.9	3.5/6.7
36'	Simple	–	–	57	91	136	192	262	345	445	561	663	752
	Multiple	–	–	81	126	182	225	272	324	379	439	503	571
	Min. Bearing	–	–	1.5/3	1.5/3	1.5/3	1.5/3	1.5/3.1	1.5/3.6	2/4.2	2.4/4.9	2.9/5.5	3.2/6.3
38'	Simple	–	–	46	75	112	160	219	289	373	472	586	667
	Multiple	–	–	66	105	155	198	240	286	335	388	445	505
	Min. Bearing	–	–	1.5/3	1.5/3	1.5/3	1.5/3	1.5/3	1.5/3.4	1.8/4	2.2/4.6	2.7/5.2	3.1/5.9
40'	Simple	–	–	–	61	93	134	183	244	316	400	497	595
	Multiple	–	–	–	87	130	176	213	253	298	345	396	449
	Min. Bearing	–	–	–	1.5/3	1.5/3	1.5/3	1.5/3	1.5/3.2	1.6/3.8	2/4.3	2.4/4.9	2.9/5.6

NOTES

- ▶ Both Architectural and Framing appearance classification BOISE GLULAM® beams have the same structural classification, 24F-V4. Appearance classification does not affect the beam's allowable design values.
- ▶ Uniform PLF load values are limited by shear, moment, total load deflection limited to L/240 and live load deflection limited to L/360.
- ▶ Live load is equal to 0.8 of total load (residential loading).
- ▶ Table values assume that lateral support is provided at each support and continuously along the compression edge of the beam.
- ▶ Span is measured center to center of the supports.
- ▶ Table values for Minimum Required Bearing Lengths are based on the allowable compression design value perpendicular to grain for the beam and the load value shown. Other design considerations, such as a weaker support material, may warrant longer bearing lengths. Table values assume that support is provided across the full width of the beam.
- ▶ Wind loading has not been considered in this table.
- ▶ Table assumes dry-use conditions.
- ▶ Table was designed to apply to a broad range of applications. It may be possible to exceed the limitations of this table by analyzing a specific application with the BC Calc® software.

BOISE GLULAM Beams Roof Load Tables

Architectural Appearance Beams — 8¾"

24F-V4 Grade — 115% Snow Load

In pounds per lineal foot (PLF)

Span	Span Type	9"	10.5"	12"	13.5"	15"	16.5"	18"	19.5"	21"	22.5"	24"
6'	Simple	6,018	8,195	10,641	12,771	15,206	18,015	21,294	25,170	29,821	35,506	42,614
	Multiple	4,635	6,312	7,732	9,114	10,634	12,315	14,183	16,272	18,621	21,285	24,329
	Min. Bearing	3.2/6.1	4.3/8.4	5.6/10.2	6.8/12.1	8/14.1	9.5/16.3	11.3/18.8	13.3/21.5	15.8/24.6	18.8/28.1	22.5/32.1
8'	Simple	3,377	4,600	6,012	7,612	9,402	11,139	12,761	14,554	16,547	18,775	21,281
	Multiple	2,599	3,541	4,628	5,861	7,079	8,057	9,104	10,230	11,442	12,752	14,171
	Min. Bearing	2.4/4.6	3.3/6.3	4.2/8.2	5.4/10.4	6.6/12.5	7.9/14.2	9/16.1	10.3/18.1	11.7/20.2	13.2/22.5	15/25
10'	Simple	2,154	2,936	3,838	4,862	5,996	7,189	8,485	9,882	11,379	12,752	14,171
	Multiple	1,656	2,258	2,953	3,741	4,615	5,534	6,532	7,454	8,251	9,095	9,988
	Min. Bearing	1.9/3.7	2.6/5	3.4/6.5	4.3/8.3	5.3/10.2	6.4/12.2	7.5/14.4	8.7/16.5	10/18.2	11.3/20.1	12.5/22.1
12'	Simple	1,490	2,032	2,658	3,336	4,078	4,891	5,774	6,725	7,745	8,833	9,988
	Multiple	1,144	1,561	2,043	2,565	3,136	3,762	4,442	5,174	5,960	6,798	7,688
	Min. Bearing	1.6/3.1	2.2/4.2	2.8/5.5	3.5/6.8	4.3/8.4	5.2/10	6.1/11.8	7.1/13.8	8.2/15.8	9.4/18.1	10.6/20.4
14'	Simple	1,014	1,487	1,921	2,405	2,942	3,529	4,166	4,854	5,591	6,377	7,212
	Multiple	836	1,141	1,475	1,848	2,260	2,712	3,203	3,732	4,299	4,905	5,548
	Min. Bearing	1.5/3	1.9/3.6	2.4/4.6	3/5.8	3.7/7.1	4.4/8.5	5.2/10	6/11.6	6.9/13.4	7.9/15.2	8.9/17.2
16'	Simple	673	1,077	1,445	1,810	2,215	2,657	3,138	3,657	4,213	4,806	5,436
	Multiple	635	857	1,108	1,389	1,700	2,040	2,410	2,809	3,237	3,694	4,178
	Min. Bearing	1.5/3	1.5/3.1	2.1/4	2.6/5	3.2/6.1	3.8/7.3	4.5/8.6	5.2/10	6/11.5	6.8/13.2	7.7/14.9
18'	Simple	467	750	1,123	1,407	1,722	2,067	2,442	2,846	3,280	3,742	4,234
	Multiple	493	664	859	1,078	1,320	1,586	1,874	2,185	2,518	2,874	3,252
	Min. Bearing	1.5/3	1.5/3	1.8/3.5	2.3/4.4	2.8/5.3	3.3/6.4	3.9/7.6	4.6/8.8	5.3/10.1	6/11.6	6.8/13.1
20'	Simple	335	540	814	1,122	1,374	1,650	1,950	2,273	2,620	2,990	3,383
	Multiple	391	528	684	858	1,052	1,264	1,494	1,743	2,009	2,294	2,596
	Min. Bearing	1.5/3	1.5/3	1.5/3.1	2/3.9	2.5/4.8	3/5.7	3.5/6.7	4.1/7.8	4.7/9	5.3/10.3	6/11.6
22'	Simple	247	400	606	870	1,119	1,344	1,589	1,853	2,137	2,439	2,760
	Multiple	317	428	555	698	855	1,028	1,216	1,419	1,637	1,869	2,116
	Min. Bearing	1.5/3	1.5/3	1.5/3	1.7/3.5	2.2/4.3	2.7/5.1	3.1/6.1	3.7/7.1	4.2/8.1	4.8/9.3	5.4/10.5
24'	Simple	186	303	461	663	918	1,114	1,317	1,537	1,772	2,024	2,291
	Multiple	251	353	458	576	707	851	1,007	1,175	1,356	1,549	1,754
	Min. Bearing	1.5/3	1.5/3	1.5/3	1.5/3.2	2/3.9	2.4/4.7	2.9/5.5	3.3/6.4	3.8/7.4	4.4/8.4	4.9/9.5
26'	Simple	142	234	357	516	715	936	1,108	1,293	1,491	1,703	1,928
	Multiple	193	295	383	483	593	714	845	987	1,139	1,302	1,475
	Min. Bearing	1.5/3	1.5/3	1.5/3	1.5/3	1.7/3.6	2.2/4.3	2.6/5	3/5.9	3.5/6.8	4/7.7	4.5/8.7
28'	Simple	110	183	281	407	566	761	942	1,100	1,270	1,451	1,643
	Multiple	151	247	324	409	503	606	718	839	969	1,107	1,255
	Min. Bearing	1.5/3	1.5/3	1.5/3	1.5/3	1.5/3.3	2/3.9	2.4/4.7	2.8/5.4	3.2/6.2	3.7/7.1	4.2/8
30'	Simple	86	144	223	326	454	612	802	946	1,093	1,249	1,415
	Multiple	119	197	277	350	431	519	616	720	832	952	1,079
	Min. Bearing	1.5/3	1.5/3	1.5/3	1.5/3	1.5/3	1.7/3.7	2.2/4.3	2.6/5	3/5.8	3.4/6.6	3.9/7.4
32'	Simple	67	115	180	263	369	498	654	821	948	1,084	1,229
	Multiple	95	158	239	302	372	449	533	623	721	825	936
	Min. Bearing	1.5/3	1.5/3	1.5/3	1.5/3	1.5/3	1.5/3.4	1.9/4	2.4/4.7	2.8/5.4	3.2/6.1	3.6/6.9
34'	Simple	53	92	145	215	302	409	539	692	830	949	1,076
	Multiple	76	128	199	262	324	391	465	544	629	721	818
	Min. Bearing	1.5/3	1.5/3	1.5/3	1.5/3	1.5/3	1.5/3.2	1.7/3.8	2.2/4.4	2.6/5	3/5.7	3.4/6.5
36'	Simple	42	74	119	176	249	339	448	577	727	836	948
	Multiple	61	105	164	229	284	343	408	478	553	634	719
	Min. Bearing	1.5/3	1.5/3	1.5/3	1.5/3	1.5/3	1.5/3	1.5/3.5	2/4.1	2.4/4.7	2.8/5.4	3.2/6.1
38'	Simple	–	60	97	146	207	283	375	484	612	741	841
	Multiple	–	86	136	201	250	302	360	422	489	560	637
	Min. Bearing	–	1.5/3	1.5/3	1.5/3	1.5/3	1.5/3	1.5/3.3	1.8/3.9	2.2/4.5	2.6/5.1	3/5.7
40'	Simple	–	48	79	121	173	238	316	409	518	644	750
	Multiple	–	70	113	168	221	268	319	375	434	498	566
	Min. Bearing	–	1.5/3	1.5/3	1.5/3	1.5/3	1.5/3	1.5/3.1	1.6/3.7	2/4.2	2.4/4.8	2.8/5.4

NOTES

- ▶ Both Architectural and Framing appearance classification BOISE GLULAM® beams have the same structural classification, 24F-V4. Appearance classification does not affect the beam's allowable design values.
- ▶ Uniform PLF load values are limited by shear, moment, total load deflection limited to L/240 and live load deflection limited to L/360.
- ▶ Live load is equal to 0.8 of total load (residential loading).
- ▶ Table values assume that lateral support is provided at each support and continuously along the compression edge of the beam.
- ▶ Span is measured center to center of the supports.
- ▶ Table values for Minimum Required Bearing Lengths are based on the allowable compression design value perpendicular to grain for the beam and the load value shown. Other design considerations, such as a weaker support material, may warrant longer bearing lengths. Table values assume that support is provided across the full width of the beam.
- ▶ Wind loading has not been considered in this table.
- ▶ Table assumes dry-use conditions.
- ▶ Table was designed to apply to a broad range of applications. It may be possible to exceed the limitations of this table by analyzing a specific application with the BC Calc® software.

BOISE GLULAM Beams Roof Load Tables

Architectural Appearance Beams — 3 1/8"

24F-V4 Grade — 125% Non-Snow Load

In pounds per lineal foot (PLF)

Span	Span Type	6"	7.5"	9"	10.5"	12"	13.5"	15"	16.5"	18"
6'	Simple	1,037	1,622	2,337	3,182	4,132	4,958	5,904	6,995	
	Multiple	798	1,249	1,800	2,451	3,002	3,539	4,129	4,782	
	Min. Bearing	1.5/3	2.4/4.6	3.5/6.7	4.7/9.1	6.1/11.1	7.3/13.1	8.7/15.3	10.3/17.7	
8'	Simple	581	910	1,312	1,786	2,335	2,956	3,651	4,325	4,955
	Multiple	447	700	1,009	1,375	1,798	2,276	2,749	3,129	3,535
	Min. Bearing	1.5/3	1.8/3.5	2.6/5	3.5/6.8	4.6/8.9	5.8/11.3	7.2/13.6	8.5/15.5	9.8/17.5
10'	Simple	295	580	837	1,140	1,491	1,888	2,332	2,823	3,361
	Multiple	285	446	644	877	1,147	1,453	1,795	2,174	2,588
	Min. Bearing	1.5/3	1.5/3	2.1/4	2.8/5.4	3.7/7.1	4.7/9	5.8/11.1	7/13.5	8.3/16
12'	Simple	169	333	579	790	1,033	1,308	1,616	1,957	2,330
	Multiple	196	308	445	607	794	1,006	1,243	1,506	1,793
	Min. Bearing	1.5/3	1.5/3	1.7/3.3	2.4/4.5	3.1/5.9	3.9/7.5	4.8/9.3	5.8/11.2	6.9/13.3
14'	Simple	105	208	362	578	756	958	1,184	1,434	1,708
	Multiple	139	225	325	444	581	736	910	1,103	1,314
	Min. Bearing	1.5/3	1.5/3	1.5/3	2/3.9	2.6/5.1	3.3/6.4	4.1/7.9	5/9.6	5.9/11.4
16'	Simple	69	137	240	385	577	731	904	1,095	1,305
	Multiple	92	171	247	338	443	561	694	841	1,003
	Min. Bearing	1.5/3	1.5/3	1.5/3	1.5/3.4	2.3/4.4	2.9/5.6	3.6/6.9	4.4/8.4	5.2/10
18'	Simple	47	95	167	268	402	576	712	863	1,028
	Multiple	63	126	194	265	348	441	546	662	789
	Min. Bearing	1.5/3	1.5/3	1.5/3	1.5/3	1.8/4	2.6/5	3.2/6.2	3.9/7.5	4.6/8.9
20'	Simple	–	68	120	193	291	417	575	696	830
	Multiple	–	91	156	213	280	356	440	534	637
	Min. Bearing	–	1.5/3	1.5/3	1.5/3	1.5/3.6	2.1/4.5	2.9/5.6	3.5/6.7	4.2/8
22'	Simple	–	49	88	143	216	311	429	573	684
	Multiple	–	67	118	175	230	292	362	439	524
	Min. Bearing	–	1.5/3	1.5/3	1.5/3	1.5/3.2	1.7/4.1	2.4/5.1	3.2/6.1	3.8/7.3
24'	Simple	–	–	66	108	164	237	328	439	570
	Multiple	–	–	89	145	192	244	302	367	436
	Min. Bearing	–	–	1.5/3	1.5/3	1.5/3	1.5/3.8	2/4.6	2.7/5.6	3.4/6.6
26'	Simple	–	–	51	84	127	184	255	342	447
	Multiple	–	–	69	112	162	206	256	310	366
	Min. Bearing	–	–	1.5/3	1.5/3	1.5/3	1.5/3.5	1.7/4.3	2.3/5.2	2.9/6.1
28'	Simple	–	–	–	65	100	145	202	272	355
	Multiple	–	–	–	88	135	176	219	263	312
	Min. Bearing	–	–	–	1.5/3	1.5/3	1.5/3.2	1.5/4	2/4.8	2.5/5.6
30'	Simple	–	–	–	52	80	116	162	219	286
	Multiple	–	–	–	70	108	152	188	226	268
	Min. Bearing	–	–	–	1.5/3	1.5/3	1.5/3	1.5/3.7	1.7/4.4	2.2/5.2
32'	Simple	–	–	–	–	64	94	132	178	234
	Multiple	–	–	–	–	87	127	162	196	232
	Min. Bearing	–	–	–	–	1.5/3	1.5/3	1.5/3.4	1.5/4.1	1.9/4.8
34'	Simple	–	–	–	–	52	77	108	146	192
	Multiple	–	–	–	–	71	104	142	171	203
	Min. Bearing	–	–	–	–	1.5/3	1.5/3	1.5/3.2	1.5/3.8	1.7/4.5
36'	Simple	–	–	–	–	–	63	89	121	160
	Multiple	–	–	–	–	–	86	121	150	178
	Min. Bearing	–	–	–	–	–	1.5/3	1.5/3	1.5/3.6	1.5/4.3
38'	Simple	–	–	–	–	–	52	74	101	134
	Multiple	–	–	–	–	–	72	101	133	158
	Min. Bearing	–	–	–	–	–	1.5/3	1.5/3	1.5/3.4	1.5/4
40'	Simple	–	–	–	–	–	–	62	85	113
	Multiple	–	–	–	–	–	–	85	116	140
	Min. Bearing	–	–	–	–	–	–	1.5/3	1.5/3.2	1.5/3.8

NOTES

- ▶ Both Architectural and Framing appearance classification BOISE GLULAM® beams have the same structural classification, 24F-V4. Appearance classification does not affect the beam's allowable design values.
- ▶ Uniform PLF load values are limited by shear, moment, total load deflection limited to L/180 and live load deflection limited to L/240.
- ▶ Live load is no greater than 0.75 of total load.
- ▶ Table values assume that lateral support is provided at each support and continuously along the compression edge of the beam.
- ▶ Span is measured center to center of the supports.
- ▶ Table values for Minimum Required Bearing Lengths are based on the allowable compression design value perpendicular to grain for the beam and the load value shown. Other design considerations, such as a weaker support material, may warrant longer bearing lengths. Table values assume that support is provided across the full width of the beam.
- ▶ Wind loading has not been considered in this table.
- ▶ Table assumes dry-use conditions.
- ▶ Table was designed to apply to a broad range of applications. It may be possible to exceed the limitations of this table by analyzing a specific application with the BC Calc® software.

BOISE GLULAM Beams Roof Load Tables

Architectural Appearance Beams — 3½"

24F-V4 Grade — 125% Non-Snow Load

In pounds per lineal foot (PLF)

Span	Span Type	6"	7.5"	9"	10.5"	12"	13.5"	15"	16.5"	18"
6'	Simple	1162	1,817	2,617	3,564	4,627	5,554	6,612	7,834	9,260
	Multiple	894	1,399	2,016	2,745	3,363	3,964	4,625	5,356	6,168
	Min. Bearing	1.5 / 3	2.4 / 4.6	3.5 / 6.7	4.7 / 9.1	6.1 / 11.1	7.3 / 13.1	8.7 / 15.3	10.3 / 17.7	12.2 / 20.4
8'	Simple	651	1,019	1,469	2,001	2,615	3,311	4,089	4,844	5,550
	Multiple	501	784	1,131	1,540	2,013	2,549	3,079	3,504	3,960
	Min. Bearing	1.5 / 3	1.8 / 3.5	2.6 / 5	3.5 / 6.8	4.6 / 8.9	5.8 / 11.3	7.2 / 13.6	8.5 / 15.5	9.8 / 17.5
10'	Simple	331	650	937	1,277	1,670	2,115	2,612	3,162	3,765
	Multiple	319	499	721	983	1,285	1,627	2,011	2,434	2,898
	Min. Bearing	1.5 / 3	1.5 / 3	2.1 / 4	2.8 / 5.4	3.7 / 7.1	4.7 / 9	5.8 / 11.1	7 / 13.5	8.3 / 16
12'	Simple	189	373	649	884	1,156	1,465	1,810	2,192	2,610
	Multiple	220	345	498	680	889	1,127	1,392	1,686	2,008
	Min. Bearing	1.5 / 3	1.5 / 3	1.7 / 3.3	2.4 / 4.5	3.1 / 5.9	3.9 / 7.5	4.8 / 9.3	5.8 / 11.2	6.9 / 13.3
14'	Simple	117	233	406	647	847	1,073	1,327	1,606	1,913
	Multiple	160	252	364	497	651	825	1,020	1,235	1,471
	Min. Bearing	1.5 / 3	1.5 / 3	1.5 / 3	2 / 3.9	2.6 / 5.1	3.3 / 6.4	4.1 / 7.9	5 / 9.6	5.9 / 11.4
16'	Simple	77	154	269	431	646	819	1,013	1,227	1,461
	Multiple	108	191	277	378	496	629	778	942	1,123
	Min. Bearing	1.5 / 3	1.5 / 3	1.5 / 3	1.5 / 3.4	2.3 / 4.4	2.9 / 5.6	3.6 / 6.9	4.4 / 8.4	5.2 / 10
18'	Simple	53	106	187	300	451	645	797	966	1,151
	Multiple	76	148	217	297	389	494	612	742	884
	Min. Bearing	1.5 / 3	1.5 / 3	1.5 / 3	1.5 / 3	1.8 / 4	2.6 / 5	3.2 / 6.2	3.9 / 7.5	4.6 / 8.9
20'	Simple	–	76	134	216	326	467	643	780	930
	Multiple	–	108	174	239	314	398	493	598	713
	Min. Bearing	–	1.5 / 3	1.5 / 3	1.5 / 3	1.5 / 3.6	2.1 / 4.5	2.9 / 5.6	3.5 / 6.7	4.2 / 8
22'	Simple	–	55	99	160	242	348	480	642	760
	Multiple	–	81	140	196	257	327	405	492	582
	Min. Bearing	–	1.5 / 3	1.5 / 3	1.5 / 3	1.5 / 3.2	1.7 / 4.1	2.4 / 5.1	3.2 / 6.1	3.7 / 7.2
24'	Simple	–	–	74	121	184	265	367	491	631
	Multiple	–	–	108	163	215	273	339	408	483
	Min. Bearing	–	–	1.5 / 3	1.5 / 3	1.5 / 3	1.5 / 3.8	2 / 4.6	2.7 / 5.6	3.4 / 6.6
26'	Simple	–	–	57	94	143	206	286	384	501
	Multiple	–	–	84	135	181	231	285	343	406
	Min. Bearing	–	–	1.5 / 3	1.5 / 3	1.5 / 3	1.5 / 3.5	1.7 / 4.3	2.3 / 5.1	2.9 / 6
28'	Simple	–	–	–	73	112	163	226	304	398
	Multiple	–	–	–	108	155	197	242	291	345
	Min. Bearing	–	–	–	1.5 / 3	1.5 / 3	1.5 / 3.2	1.5 / 3.9	2 / 4.7	2.5 / 5.5
30'	Simple	–	–	–	58	89	130	182	245	321
	Multiple	–	–	–	86	131	169	208	250	296
	Min. Bearing	–	–	–	1.5 / 3	1.5 / 3	1.5 / 3	1.5 / 3.6	1.7 / 4.4	2.2 / 5.1
32'	Simple	–	–	–	–	72	105	147	199	262
	Multiple	–	–	–	–	107	146	180	217	257
	Min. Bearing	–	–	–	–	1.5 / 3	1.5 / 3	1.5 / 3.4	1.5 / 4.1	1.9 / 4.8
34'	Simple	–	–	–	–	58	86	121	164	216
	Multiple	–	–	–	–	87	127	157	189	224
	Min. Bearing	–	–	–	–	1.5 / 3	1.5 / 3	1.5 / 3.2	1.5 / 3.8	1.7 / 4.5
36'	Simple	–	–	–	–	–	71	100	136	179
	Multiple	–	–	–	–	–	105	138	166	197
	Min. Bearing	–	–	–	–	–	1.5 / 3	1.5 / 3	1.5 / 3.6	1.5 / 4.2
38'	Simple	–	–	–	–	–	58	83	113	150
	Multiple	–	–	–	–	–	88	121	147	174
	Min. Bearing	–	–	–	–	–	1.5 / 3	1.5 / 3	1.5 / 3.4	1.5 / 4
40'	Simple	–	–	–	–	–	–	69	95	126
	Multiple	–	–	–	–	–	–	104	130	155
	Min. Bearing	–	–	–	–	–	–	1.5 / 3	1.5 / 3.2	1.5 / 3.7

NOTES

- ▶ Both Architectural and Framing appearance classification BOISE GLULAM® beams have the same structural classification, 24F-V4. Appearance classification does not affect the beam's allowable design values.
- ▶ Uniform PLF load values are limited by shear, moment, total load deflection limited to L/180 and live load deflection limited to L/240.
- ▶ Live load is no greater than 0.75 of total load.
- ▶ Table values assume that lateral support is provided at each support and continuously along the compression edge of the beam.
- ▶ Span is measured center to center of the supports.
- ▶ Table values for Minimum Required Bearing Lengths are based on the allowable compression design value perpendicular to grain for the beam and the load value shown. Other design considerations, such as a weaker support material, may warrant longer bearing lengths. Table values assume that support is provided across the full width of the beam.
- ▶ Wind loading has not been considered in this table.
- ▶ Table assumes dry-use conditions.
- ▶ Table was designed to apply to a broad range of applications. It may be possible to exceed the limitations of this table by analyzing a specific application with the BC Calc® software.

BOISE GLULAM Beams Roof Load Tables

Architectural Appearance Beams — 5/8"

24F-V4 Grade — 125% Non-Snow Load

In pounds per lineal foot (PLF)

Span	Span Type	6"	7.5"	9"	10.5"	12"	13.5"	15"	16.5"	18"	19.5"	21"	22.5"	24"
6'	Simple	1,701	2,660	3,833	5,219	6,776	8,132	9,682	11,471					
	Multiple	1,309	2,048	2,952	4,020	4,924	5,804	6,772	7,842					
	Min. Bearing	1.5/3	2.4/4.6	3.5/6.7	4.7/9.1	6.1/11.1	7.3/13.1	8.7/15.3	10.3/17.7					
8'	Simple	953	1,492	2,151	2,930	3,829	4,848	5,987	7,093	8,126	9,268			
	Multiple	733	1,148	1,655	2,255	2,948	3,733	4,508	5,131	5,798	6,515			
	Min. Bearing	1.5/3	1.8/3.5	2.6/5	3.5/6.8	4.6/8.9	5.8/11.3	7.2/13.6	8.5/15.5	9.8/17.5	11.2/19.6			
10'	Simple	485	952	1,373	1,870	2,445	3,097	3,825	4,630	5,513	6,472	7,287		
	Multiple	467	731	1,055	1,439	1,881	2,383	2,944	3,565	4,244	4,748	5,255		
	Min. Bearing	1.5/3	1.5/3	2.1/4	2.8/5.4	3.7/7.1	4.7/9	5.8/11.1	7/13.5	8.3/16	9.7/17.9	11/19.8		
12'	Simple	277	547	950	1,295	1,693	2,145	2,651	3,209	3,821	4,487	5,206	5,937	
	Multiple	322	505	730	995	1,302	1,650	2,039	2,469	2,940	3,453	4,007	4,499	
	Min. Bearing	1.5/3	1.5/3	1.7/3.3	2.4/4.5	3.1/5.9	3.9/7.5	4.8/9.3	5.8/11.2	6.9/13.3	8.1/15.7	9.4/18.2	10.7/20.4	
14'	Simple	172	341	594	948	1,240	1,572	1,942	2,352	2,802	3,264	3,759	4,287	4,848
	Multiple	228	369	533	728	953	1,208	1,493	1,809	2,154	2,510	2,891	3,298	3,730
	Min. Bearing	1.5/3	1.5/3	1.5/3	2/3.9	2.6/5.1	3.3/6.4	4.1/7.9	5/9.6	5.9/11.4	6.9/13.3	8/15.3	9.1/17.5	10.3/19.8
16'	Simple	113	225	394	631	946	1,199	1,483	1,788	2,111	2,460	2,833	3,232	3,655
	Multiple	151	280	405	554	726	921	1,139	1,373	1,622	1,890	2,178	2,485	2,811
	Min. Bearing	1.5/3	1.5/3	1.5/3	1.5/3.4	2.3/4.4	2.9/5.6	3.6/6.9	4.3/8.4	5.1/9.9	6/11.5	6.9/13.2	7.8/15.1	8.9/17.1
18'	Simple	77	155	274	439	660	944	1,160	1,392	1,644	1,915	2,207	2,518	2,848
	Multiple	103	207	318	435	570	724	889	1,068	1,262	1,471	1,695	1,934	2,188
	Min. Bearing	1.5/3	1.5/3	1.5/3	1.5/3	1.8/4	2.6/5	3.2/6.1	3.8/7.4	4.5/8.7	5.2/10.1	6/11.6	6.9/13.3	7.8/15
20'	Simple	54	111	196	317	477	684	926	1,111	1,313	1,530	1,763	2,012	2,277
	Multiple	73	149	255	350	459	579	709	852	1,007	1,174	1,353	1,545	1,748
	Min. Bearing	1.5/3	1.5/3	1.5/3	1.5/3	1.5/3.6	2.1/4.5	2.8/5.5	3.4/6.5	4/7.7	4.7/9	5.4/10.4	6.1/11.8	6.9/13.3
22'	Simple	–	81	145	235	355	509	703	906	1,071	1,248	1,439	1,642	1,858
	Multiple	–	109	194	287	375	471	577	694	820	957	1,103	1,259	1,426
	Min. Bearing	–	1.5/3	1.5/3	1.5/3	1.5/3.2	1.7/4	2.4/4.9	3.1/5.9	3.6/7	4.2/8.1	4.8/9.3	5.5/10.6	6.2/12
24'	Simple	–	60	109	178	270	389	537	720	888	1,036	1,194	1,363	1,543
	Multiple	–	82	147	238	310	389	478	574	679	793	915	1,044	1,182
	Min. Bearing	–	1.5/3	1.5/3	1.5/3	1.5/3	1.5/3.7	2/4.5	2.7/5.4	3.3/6.3	3.8/7.4	4.4/8.5	5/9.7	5.7/10.9
26'	Simple	–	45	83	137	209	302	419	562	733	872	1,005	1,148	1,300
	Multiple	–	63	113	184	260	327	401	482	571	666	769	878	995
	Min. Bearing	–	1.5/3	1.5/3	1.5/3	1.5/3	1.5/3.4	1.7/4.1	2.3/4.9	2.9/5.8	3.5/6.7	4/7.8	4.6/8.8	5.2/10
28'	Simple	–	–	64	107	164	238	332	446	583	743	857	979	1,108
	Multiple	–	–	88	145	220	277	340	410	485	567	654	748	847
	Min. Bearing	–	–	1.5/3	1.5/3	1.5/3	1.5/3.1	1.5/3.8	2/4.5	2.5/5.3	3.2/6.2	3.7/7.2	4.2/8.2	4.8/9.2
30'	Simple	–	–	50	85	131	191	266	358	470	601	738	843	954
	Multiple	–	–	70	115	177	237	292	352	417	487	563	643	729
	Min. Bearing	–	–	1.5/3	1.5/3	1.5/3	1.5/3	1.5/3.5	1.7/4.2	2.2/4.9	2.8/5.8	3.4/6.6	3.9/7.6	4.4/8.5
32'	Simple	–	–	–	67	105	154	216	292	383	491	618	732	830
	Multiple	–	–	–	93	143	205	253	305	361	422	488	558	633
	Min. Bearing	–	–	–	1.5/3	1.5/3	1.5/3	1.5/3.3	1.5/3.9	1.9/4.6	2.5/5.4	3.1/6.2	3.7/7	4.1/8
34'	Simple	–	–	–	54	85	126	177	240	316	405	511	632	727
	Multiple	–	–	–	75	117	171	220	266	315	369	427	488	554
	Min. Bearing	–	–	–	1.5/3	1.5/3	1.5/3	1.5/3	1.5/3.7	1.7/4.3	2.2/5	2.7/5.8	3.4/6.6	3.9/7.4
36'	Simple	–	–	–	–	69	103	146	199	262	338	426	528	641
	Multiple	–	–	–	–	96	141	193	233	277	324	375	430	488
	Min. Bearing	–	–	–	–	1.5/3	1.5/3	1.5/3	1.5/3.4	1.5/4	2/4.7	2.4/5.4	3/6.2	3.6/7
38'	Simple	–	–	–	–	57	85	121	166	220	284	358	445	544
	Multiple	–	–	–	–	79	118	166	206	245	287	332	381	432
	Min. Bearing	–	–	–	–	1.5/3	1.5/3	1.5/3	1.5/3.2	1.5/3.8	1.8/4.4	2.2/5.1	2.7/5.8	3.3/6.6
40'	Simple	–	–	–	–	47	71	101	139	185	240	303	377	462
	Multiple	–	–	–	–	66	98	139	183	218	255	296	339	385
	Min. Bearing	–	–	–	–	1.5/3	1.5/3	1.5/3	1.5/3.1	1.5/3.6	1.6/4.2	2/4.8	2.4/5.5	3/6.2

NOTES

- ▶ Both Architectural and Framing appearance classification BOISE GLULAM® beams have the same structural classification, 24F-V4. Appearance classification does not affect the beam's allowable design values.
- ▶ Uniform PLF load values are limited by shear, moment, total load deflection limited to L/180 and live load deflection limited to L/240.
- ▶ Live load is no greater than 0.75 of total load.
- ▶ Table values assume that lateral support is provided at each support and continuously along the compression edge of the beam.
- ▶ Span is measured center to center of the supports.
- ▶ Table values for Minimum Required Bearing Lengths are based on the allowable compression design value perpendicular to grain for the beam and the load value shown. Other design considerations, such as a weaker support material, may warrant longer bearing lengths. Table values assume that support is provided across the full width of the beam.
- ▶ Wind loading has not been considered in this table.
- ▶ Table assumes dry-use conditions.
- ▶ Table was designed to apply to a broad range of applications. It may be possible to exceed the limitations of this table by analyzing a specific application with the BC Calc® software.

BOISE GLULAM Beams Roof Load Tables

Architectural Appearance Beams — 5½"

24F-V4 Grade — 125% Non-Snow Load

In pounds per lineal foot (PLF)

Span	Span Type	6"	7.5"	9"	10.5"	12"	13.5"	15"	16.5"	18"	19.5"	21"	22.5"	24"
6'	Simple	1,825	2,855	4,113	5,601	7,271	8,,727	10,391	12,311	14,551	17,199	20,377	24,262	28,568
	Multiple	1,405	2,198	3,168	4,314	5,284	6,228	7,267	8,416	9,693	11,120	12,725	14,270	14,268
	Min. Bearing	1.5 / 3	2.4 / 4.6	3.5 / 6.7	4.7 / 9.1	6.1 / 11.1	7.3 / 13.1	8.7 / 15.3	10.3 / 17.7	12.2 / 20.4	14.5 / 23.4	17.1 / 26.8	20.4 / 30	24 / 30
8'	Simple	1,023	1,601	2,308	3,144	4,109	5,203	6,425	7,612	8,721	9,946	11,308	12,830	14,543
	Multiple	787	1,232	1,777	2,420	3,164	4,006	4,838	5,506	6,222	6,992	7,820	8,715	9,,685
	Min. Bearing	1.5 / 3	1.8 / 3.5	2.6 / 5	3.5 / 6.8	4.6 / 8.9	5.8 / 11.3	7.2 / 13.6	8.5 / 15.5	9.8 / 17.5	11.2 / 19.6	12.7 / 22	14.4 / 24.5	16.3 / 27.2
10'	Simple	520	1,021	1,473	2,007	2,624	3,323	4,105	4,969	5,916	6,945	7,820	8,715	9685
	Multiple	501	785	1,133	1,544	2,019	2,557	3,160	3,825	4,555	5,095	5,640	6,216	6,827
	Min. Bearing	1.5 / 3	1.5 / 3	2.1 / 4	2.8 / 5.4	3.7 / 7.1	4.7 / 9	5.8 / 11.1	7 / 13.5	8.3 / 16	9.7 / 17.9	11 / 19.8	12.2 / 21.8	13.6 / 24
12'	Simple	298	587	1,019	1,390	1,817	2,302	2,845	3,444	4,101	4,815	5,547	6,326	7,153
	Multiple	345	542	783	1,068	1,397	1,771	2,188	2,650	3,156	3,706	4,269	4,828	5,268
	Min. Bearing	1.5 / 3	1.5 / 3	1.7 / 3.3	2.4 / 4.5	3.1 / 5.9	3.9 / 7.5	4.8 / 9.3	5.8 / 11.2	6.9 / 13.3	8.1 / 15.7	9.4 / 18	10.7 / 20.4	12.1 / 22.2
14'	Simple	184	366	637	1,017	1,331	1,687	2,085	2,524	2,985	3,478	4,005	4,568	5,166
	Multiple	252	396	572	781	1,022	1,296	1,602	1,941	2,296	2,675	3,081	3,514	3,975
	Min. Bearing	1.5 / 3	1.5 / 3	1.5 / 3	2 / 3.9	2.6 / 5.1	3.3 / 6.4	4.1 / 7.9	5 / 9.6	5.9 / 11.4	6.9 / 13.2	7.9 / 15.2	9 / 17.4	10.2 / 19.6
16'	Simple	121	242	423	677	1,015	1,287	1,588	1,905	2,249	2,621	3,019	3,444	3,895
	Multiple	170	300	435	595	779	988	1,219	1,463	1,728	2,014	2,321	2,648	2,995
	Min. Bearing	1.5 / 3	1.5 / 3	1.5 / 3	1.5 / 3.4	2.3 / 4.4	2.9 / 5.6	3.6 / 6.9	4.3 / 8.3	5.1 / 9.8	5.9 / 11.4	6.8 / 13.1	7.8 / 15	8.8 / 16.9
18'	Simple	83	167	294	471	708	1,010	1,235	1,483	1,751	2,041	2,351	2,683	3,034
	Multiple	119	233	341	467	612	774	948	1,138	1,344	1,567	1,806	2,061	2,332
	Min. Bearing	1.5 / 3	1.5 / 3	1.5 / 3	1.5 / 3	1.8 / 4	2.6 / 5	3.2 / 6.1	3.8 / 7.3	4.5 / 8.6	5.2 / 10	6 / 11.5	6.8 / 13.2	7.7 / 14.9
20'	Simple	58	119	211	340	512	734	986	1,184	1,399	1,631	1,879	2,144	2,426
	Multiple	86	170	274	375	492	617	756	908	1,073	1,251	1,442	1,646	1,862
	Min. Bearing	1.5 / 3	1.5 / 3	1.5 / 3	1.5 / 3	1.5 / 3.5	2.1 / 4.4	2.8 / 5.4	3.4 / 6.5	4 / 7.7	4.6 / 8.9	5.3 / 10.3	6.1 / 11.7	6.9 / 13.2
22'	Simple	–	87	155	252	381	547	755	965	1,141	1,330	1,533	1,750	1,980
	Multiple	–	127	220	308	400	502	615	739	874	1,019	1,175	1,342	1,519
	Min. Bearing	–	1.5 / 3	1.5 / 3	1.5 / 3	1.5 / 3.2	1.7 / 4	2.4 / 4.9	3 / 5.9	3.6 / 6.9	4.2 / 8	4.8 / 9.3	5.5 / 10.6	6.2 / 11.9
24'	Simple	–	65	117	191	290	417	577	772	946	1,104	1,272	1,453	1,644
	Multiple	–	96	170	255	330	415	509	612	724	845	974	1,113	1,260
	Min. Bearing	–	1.5 / 3	1.5 / 3	1.5 / 3	1.5 / 3	1.5 / 3.6	2 / 4.4	2.7 / 5.3	3.3 / 6.3	3.8 / 7.3	4.4 / 8.4	5 / 9.6	5.6 / 10.8
26'	Simple	–	–	89	147	224	324	449	603	787	929	1,071	1,223	1,385
	Multiple	–	–	132	212	277	348	427	514	608	710	819	936	1,060
	Min. Bearing	–	–	1.5 / 3	1.5 / 3	1.5 / 3	1.5 / 3.3	1.7 / 4.1	2.3 / 4.9	2.9 / 5.7	3.5 / 6.7	4 / 7.7	4.6 / 8.8	5.2 / 9.9
28'	Simple	–	–	69	115	176	256	356	478	625	791	913	1,043	1,180
	Multiple	–	–	103	169	234	295	363	437	517	604	697	797	903
	Min. Bearing	–	–	1.5 / 3	1.5 / 3	1.5 / 3	1.5 / 3.1	1.5 / 3.7	2 / 4.5	2.5 / 5.3	3.2 / 6.2	3.7 / 7.1	4.2 / 8.1	4.7 / 9.2
30'	Simple	–	–	54	91	140	205	286	385	504	645	786	898	1017
	Multiple	–	–	82	135	201	253	311	375	444	519	599	685	776
	Min. Bearing	–	–	1.5 / 3	1.5 / 3	1.5 / 3	1.5 / 3	1.5 / 3.5	1.7 / 4.2	2.2 / 4.9	2.8 / 5.7	3.4 / 6.6	3.9 / 7.5	4.4 / 8.5
32'	Simple	–	–	–	72	113	165	232	313	411	527	663	780	884
	Multiple	–	–	–	109	167	219	269	324	385	450	520	595	674
	Min. Bearing	–	–	–	1.5 / 3	1.5 / 3	1.5 / 3	1.5 / 3.2	1.5 / 3.9	1.9 / 4.6	2.5 / 5.3	3.1 / 6.1	3.6 / 7	4.1 / 7.9
34'	Simple	–	–	–	58	91	135	190	257	339	435	548	678	774
	Multiple	–	–	–	88	137	190	234	283	336	393	454	520	590
	Min. Bearing	–	–	–	1.5 / 3	1.5 / 3	1.5 / 3	1.5 / 3	1.5 / 3.6	1.7 / 4.3	2.2 / 5	2.7 / 5.7	3.4 / 6.5	3.8 / 7.4
36'	Simple	–	–	–	–	74	111	157	213	281	362	457	567	683
	Multiple	–	–	–	–	113	165	206	249	295	346	400	458	519
	Min. Bearing	–	–	–	–	1.5 / 3	1.5 / 3	1.5 / 3	1.5 / 3.4	1.5 / 4	2 / 4.7	2.4 / 5.4	3 / 6.1	3.6 / 6.9
38'	Simple	–	–	–	–	61	92	130	178	236	304	384	477	584
	Multiple	–	–	–	–	94	138	181	219	261	306	354	405	460
	Min. Bearing	–	–	–	–	1.5 / 3	1.5 / 3	1.5 / 3	1.5 / 3.2	1.5 / 3.8	1.8 / 4.4	2.2 / 5.1	2.7 / 5.8	3.3 / 6.5
40'	Simple	–	–	–	–	–	76	109	150	199	257	326	405	496
	Multiple	–	–	–	–	–	116	161	195	232	272	315	361	410
	Min. Bearing	–	–	–	–	–	1.5 / 3	1.5 / 3	1.5 / 3	1.5 / 3.6	1.6 / 4.2	2 / 4.8	2.4 / 5.5	3 / 6.2

NOTES

- ▶ Both Architectural and Framing appearance classification BOISE GLULAM® beams have the same structural classification, 24F-V4. Appearance classification does not affect the beam's allowable design values.
- ▶ Uniform PLF load values are limited by shear, moment, total load deflection limited to L/180 and live load deflection limited to L/240.
- ▶ Live load is no greater than 0.75 of total load.
- ▶ Table values assume that lateral support is provided at each support and continuously along the compression edge of the beam.
- ▶ Span is measured center to center of the supports.
- ▶ Table values for Minimum Required Bearing Lengths are based on the allowable compression design value perpendicular to grain for the beam and the load value shown. Other design considerations, such as a weaker support material, may warrant longer bearing lengths. Table values assume that support is provided across the full width of the beam.
- ▶ Wind loading has not been considered in this table.
- ▶ Table assumes dry-use conditions.
- ▶ Table was designed to apply to a broad range of applications. It may be possible to exceed the limitations of this table by analyzing a specific application with the BC Calc® software.

BOISE GLULAM Beams Roof Load Tables

Architectural Appearance Beams — 6¾"

24F-V4 Grade — 125% Non-Snow Load

In pounds per lineal foot (PLF)

Span	Span Type	7.5"	9"	10.5"	12"	13.5"	15"	16.5"	18"	19.5"	21"	22.5"	24"
6'	Simple	3,503	5,048	6,873	8,924	10,710	12,752	15,109					
	Multiple	2,698	3,888	5,294	6,485	7,644	8,919	10,329					
	Min. Bearing	2.4/4.6	3.5/6.7	4.7/9.1	6.1/11.1	7.3/13.1	8.7/15.3	10.3/17.7					
8'	Simple	1,965	2,833	3,859	5,043	6,385	7,886	9,343	10,703	12,207			
	Multiple	1,512	2,180	2,971	3,883	4,917	5,938	6,758	7,637	8,581			
	Min. Bearing	1.8/3.5	2.6/5	3.5/6.8	4.6/8.9	5.8/11.3	7.2/13.6	8.5/15.5	9.8/17.5	11.2/19.6			
10'	Simple	1,253	1,808	2,463	3,220	4,078	5,038	6,099	7,260	8,507	9,597		
	Multiple	963	1,390	1,895	2,478	3,139	3,878	4,695	5,590	6,253	6,922		
	Min. Bearing	1.5/3	2.1/4	2.8/5.4	3.7/7.1	4.7/9	5.8/11.1	7/13.5	8.3/16	9.7/17.9	11/19.8		
12'	Simple	720	1,251	1,705	2,230	2,826	3,491	4,212	4,972	5,791	6,669	7,605	8,600
	Multiple	665	961	1,311	1,715	2,173	2,685	3,241	3,826	4,457	5,133	5,854	6,465
	Min. Bearing	1.5/3	1.7/3.3	2.4/4.5	3.1/5.9	3.9/7.5	4.8/9.3	5.8/11.2	6.8/13.2	8/15.3	9.2/17.7	10.5/20.1	11.8/22.2
14'	Simple	449	782	1,248	1,633	2,070	2,534	3,040	3,589	4,181	4,815	5,492	6,211
	Multiple	485	702	958	1,255	1,591	1,948	2,337	2,760	3,215	3,704	4,225	4,778
	Min. Bearing	1.5/3	1.5/3	2/3.9	2.6/5.1	3.3/6.4	4.1/7.9	4.9/9.4	5.8/11.1	6.7/13	7.7/14.9	8.8/17	10/19.2
16'	Simple	297	519	831	1,245	1,560	1,909	2,290	2,704	3,151	3,629	4,140	4,682
	Multiple	369	534	730	956	1,198	1,466	1,759	2,078	2,421	2,790	3,183	3,600
	Min. Bearing	1.5/3	1.5/3	1.5/3.4	2.3/4.4	2.9/5.6	3.5/6.8	4.2/8.1	5/9.6	5.8/11.2	6.7/12.9	7.6/14.7	8.6/16.6
18'	Simple	205	360	578	869	1,214	1,485	1,782	2,105	2,453	2,826	3,225	3,648
	Multiple	273	419	573	742	930	1,139	1,368	1,616	1,884	2,171	2,477	2,803
	Min. Bearing	1.5/3	1.5/3	1.5/3	1.8/3.9	2.5/4.9	3.1/6	3.7/7.2	4.4/8.4	5.1/9.8	5.9/11.3	6.7/12.9	7.6/14.6
20'	Simple	146	259	417	628	900	1,185	1,423	1,681	1,960	2,259	2,577	2,916
	Multiple	196	336	456	591	741	908	1,091	1,289	1,503	1,733	1,978	2,239
	Min. Bearing	1.5/3	1.5/3	1.5/3	1.5/3.5	2.1/4.4	2.8/5.3	3.3/6.4	3.9/7.5	4.5/8.7	5.2/10.1	6/11.5	6.7/13
22'	Simple	107	191	309	467	671	926	1,160	1,371	1,599	1,843	2,103	2,380
	Multiple	144	255	370	480	603	739	888	1,050	1,225	1,412	1,613	1,825
	Min. Bearing	1.5/3	1.5/3	1.5/3	1.5/3.1	1.7/3.9	2.4/4.8	3/5.7	3.5/6.8	4.1/7.9	4.7/9.1	5.4/10.3	6.1/11.7
24'	Simple	79	143	234	355	512	708	948	1,137	1,326	1,529	1,746	1,976
	Multiple	108	193	306	397	498	611	735	870	1,015	1,171	1,337	1,514
	Min. Bearing	1.5/3	1.5/3	1.5/3	1.5/3	1.5/3.6	2/4.3	2.7/5.2	3.2/6.1	3.7/7.2	4.3/8.2	4.9/9.4	5.5/10.6
26'	Simple	60	110	180	275	398	551	740	957	1,116	1,287	1,470	1,664
	Multiple	82	149	243	332	418	513	617	731	853	984	1,125	1,274
	Min. Bearing	1.5/3	1.5/3	1.5/3	1.5/3	1.5/3.3	1.7/4	2.3/4.8	2.9/5.6	3.4/6.6	3.9/7.5	4.5/8.6	5/9.7
28'	Simple	45	85	141	216	314	437	587	767	951	1,097	1,253	1,419
	Multiple	64	116	191	281	354	436	524	621	725	838	957	1,084
	Min. Bearing	1.5/3	1.5/3	1.5/3	1.5/3	1.5/3	1.5/3.7	2/4.4	2.5/5.2	3.1/6	3.6/7	4.1/7.9	4.7/9
30'	Simple	–	66	111	172	251	350	472	618	792	944	1,079	1,222
	Multiple	–	92	152	233	304	373	450	533	623	720	823	933
	Min. Bearing	–	1.5/3	1.5/3	1.5/3	1.5/3	1.5/3.4	1.7/4.1	2.2/4.8	2.8/5.6	3.3/6.4	3.8/7.4	4.3/8.3
32'	Simple	–	52	89	139	203	284	384	504	647	813	937	1,062
	Multiple	–	73	122	188	262	323	390	462	540	624	714	810
	Min. Bearing	–	1.5/3	1.5/3	1.5/3	1.5/3	1.5/3.2	1.5/3.8	1.9/4.5	2.5/5.2	3.1/6	3.6/6.8	4/7.7
34'	Simple	–	–	71	112	166	233	316	416	534	672	821	930
	Multiple	–	–	99	154	225	281	340	403	472	546	624	708
	Min. Bearing	–	–	1.5/3	1.5/3	1.5/3	1.5/3	1.5/3.6	1.7/4.2	2.2/4.9	2.7/5.6	3.3/6.4	3.8/7.2
36'	Simple	–	–	57	91	136	192	262	345	445	561	696	821
	Multiple	–	–	81	126	186	247	298	354	415	480	550	624
	Min. Bearing	–	–	1.5/3	1.5/3	1.5/3	1.5/3	1.5/3.3	1.5/3.9	2/4.6	2.4/5.3	3/6	3.5/6.8
38'	Simple	–	–	46	75	112	160	219	289	373	472	586	716
	Multiple	–	–	66	105	155	218	263	313	367	425	487	552
	Min. Bearing	–	–	1.5/3	1.5/3	1.5/3	1.5/3	1.5/3.1	1.5/3.7	1.8/4.3	2.2/5	2.7/5.7	3.3/6.4
40'	Simple	–	–	–	61	93	134	183	244	316	400	497	609
	Multiple	–	–	–	87	130	183	234	278	326	378	433	492
	Min. Bearing	–	–	–	1.5/3	1.5/3	1.5/3	1.5/3	1.5/3.5	1.6/4.1	2/4.7	2.4/5.4	3/6.1

NOTES

- ▶ Both Architectural and Framing appearance classification BOISE GLULAM® beams have the same structural classification, 24F-V4. Appearance classification does not affect the beam's allowable design values.
- ▶ Uniform PLF load values are limited by shear, moment, total load deflection limited to L/180 and live load deflection limited to L/240.
- ▶ Live load is no greater than 0.75 of total load.
- ▶ Table values assume that lateral support is provided at each support and continuously along the compression edge of the beam.
- ▶ Span is measured center to center of the supports.
- ▶ Table values for Minimum Required Bearing Lengths are based on the allowable compression design value perpendicular to grain for the beam and the load value shown. Other design considerations, such as a weaker support material, may warrant longer bearing lengths. Table values assume that support is provided across the full width of the beam.
- ▶ Wind loading has not been considered in this table.
- ▶ Table assumes dry-use conditions.
- ▶ Table was designed to apply to a broad range of applications. It may be possible to exceed the limitations of this table by analyzing a specific application with the BC Calc® software.

BOISE GLULAM Beams Roof Load Tables

Architectural Appearance Beams — 8¾"

24F-V4 Grade — 125% Non-Snow Load

In pounds per lineal foot (PLF)

Span	Span Type	9"	10.5"	12"	13.5"	15"	16.5"	18"	19.5"	21"	22.5"	24"
6'	Simple	6,543	8,910	11,568	13,884	16,531	19,585	23,149	27,362	32,418	38,598	46,324
	Multiple	5,039	6,863	8,406	9,909	11,562	13,389	15,420	17,690	20,244	23,140	26,449
	Min. Bearing	3.5/6.7	4.7/9.1	6.1/11.1	7.3/13.1	8.7/15.3	10.3/17.7	12.2/20.4	14.5/23.4	17.1/26.8	20.4/30.6	24.5/34.9
8'	Simple	3,672	5,002	6,537	8,277	10,222	12,111	13,874	15,824	17,990	20,412	23,136
	Multiple	2,826	3,851	5,033	6,374	7,697	8,760	9,899	11,123	12,441	13,865	15,407
	Min. Bearing	2.6/5	3.5/6.8	4.6/8.9	5.8/11.3	7.2/13.6	8.5/15.5	9.8/17.5	11.2/19.6	12.7/22	14.4/24.5	16.3/27.2
10'	Simple	2,343	3,193	4,174	5,287	6,520	7,818	9,226	10,745	12,372	13,865	15,407
	Multiple	1,802	2,456	3,212	4,069	5,019	6,018	7,103	8,105	9,273	9,890	10,861
	Min. Bearing	2.1/4	2.8/5.4	3.7/7.1	4.7/9	5.8/11.1	6.9/13.3	8.1/15.7	9.5/17.9	10.9/19.8	12.2/21.8	13.6/24
12'	Simple	1,621	2,211	2,891	3,628	4,436	5,320	6,279	7,313	8,422	9,605	10,861
	Multiple	1,246	1,699	2,223	2,790	3,412	4,092	4,831	5,628	6,482	7,393	8,361
	Min. Bearing	1.7/3.3	2.4/4.5	3.1/5.9	3.9/7.4	4.7/9.1	5.6/10.9	6.7/12.8	7.8/15	8.9/17.2	10.2/19.6	11.5/22.2
14'	Simple	1,014	1,618	2,090	2,617	3,200	3,839	4,532	5,280	6,081	6,936	7,844
	Multiple	910	1,242	1,605	2,011	2,460	2,951	3,485	4,060	4,677	5,335	6,034
	Min. Bearing	1.5/3	2/3.9	2.6/5	3.3/6.3	4/7.7	4.8/9.2	5.6/10.8	6.5/12.6	7.5/14.5	8.6/16.6	9.7/18.7
16'	Simple	673	1,077	1,573	1,970	2,410	2,892	3,414	3,978	4,583	5,228	5,913
	Multiple	692	933	1,206	1,512	1,850	2,221	2,623	3,057	3,522	4,019	4,546
	Min. Bearing	1.5/3	1.5/3.4	2.2/4.3	2.8/5.4	3.4/6.6	4.1/7.9	4.9/9.4	5.7/10.9	6.5/12.5	7.4/14.3	8.4/16.2
18'	Simple	467	750	1,127	1,532	1,875	2,250	2,658	3,098	3,569	4,072	4,606
	Multiple	538	724	936	1,174	1,438	1,726	2,040	2,378	2,741	3,128	3,539
	Min. Bearing	1.5/3	1.5/3	1.8/3.8	2.5/4.8	3/5.8	3.6/7	4.3/8.2	5/9.6	5.7/11	6.5/12.6	7.4/14.2
20'	Simple	335	540	814	1,167	1,496	1,797	2,123	2,474	2,852	3,254	3,682
	Multiple	427	576	745	936	1,146	1,377	1,627	1,898	2,188	2,497	2,826
	Min. Bearing	1.5/3	1.5/3	1.5/3.4	2.1/4.2	2.7/5.2	3.2/6.2	3.8/7.3	4.4/8.5	5.1/9.8	5.8/11.2	6.6/12.6
22'	Simple	247	400	606	870	1,201	1,464	1,731	2,018	2,326	2,655	3,005
	Multiple	331	467	606	761	932	1,121	1,325	1,546	1,783	2,036	2,304
	Min. Bearing	1.5/3	1.5/3	1.5/3.1	1.7/3.8	2.4/4.7	2.9/5.6	3.4/6.6	4/7.7	4.6/8.8	5.2/10.1	5.9/11.4
24'	Simple	186	303	461	663	918	1,214	1,435	1,674	1,930	2,204	2,494
	Multiple	251	386	500	629	771	928	1,098	1,281	1,478	1,688	1,911
	Min. Bearing	1.5/3	1.5/3	1.5/3	1.5/3.5	2/4.2	2.6/5.1	3.1/6	3.6/7	4.2/8	4.8/9.2	5.4/10.3
26'	Simple	142	234	357	516	715	959	1,207	1,409	1,625	1,855	2,101
	Multiple	193	315	419	527	647	779	922	1,076	1,242	1,419	1,607
	Min. Bearing	1.5/3	1.5/3	1.5/3	1.5/3.2	1.7/3.9	2.3/4.7	2.8/5.5	3.3/6.4	3.8/7.4	4.4/8.4	4.9/9.5
28'	Simple	110	183	281	407	566	761	995	1,200	1,384	1,581	1,790
	Multiple	151	247	355	447	549	661	783	915	1,057	1,208	1,368
	Min. Bearing	1.5/3	1.5/3	1.5/3	1.5/3	1.5/3.6	2/4.3	2.5/5.1	3.1/5.9	3.5/6.8	4/7.7	4.5/8.7
30'	Simple	86	144	223	326	454	612	802	1,027	1,191	1,361	1,542
	Multiple	119	197	302	383	471	567	673	786	908	1,038	1,177
	Min. Bearing	1.5/3	1.5/3	1.5/3	1.5/3	1.5/3.3	1.7/4	2.2/4.7	2.8/5.5	3.3/6.3	3.7/7.2	4.2/8.1
32'	Simple	67	115	180	263	369	498	654	839	1,035	1,183	1,340
	Multiple	95	158	244	331	407	491	583	681	787	901	1,021
	Min. Bearing	1.5/3	1.5/3	1.5/3	1.5/3	1.5/3.1	1.5/3.7	1.9/4.4	2.5/5.1	3/5.9	3.5/6.7	3.9/7.5
34'	Simple	53	92	145	215	302	409	539	692	872	1,036	1,174
	Multiple	76	128	199	288	355	428	508	595	688	787	893
	Min. Bearing	1.5/3	1.5/3	1.5/3	1.5/3	1.5/3	1.5/3.5	1.7/4.1	2.2/4.8	2.7/5.5	3.2/6.2	3.7/7.1
36'	Simple	42	74	119	176	249	339	448	577	727	902	1,035
	Multiple	61	105	164	241	311	376	446	523	605	693	786
	Min. Bearing	1.5/3	1.5/3	1.5/3	1.5/3	1.5/3	1.5/3.3	1.5/3.8	2/4.5	2.4/5.1	3/5.9	3.4/6.6
38'	Simple	–	60	97	146	207	283	375	484	612	759	919
	Multiple	–	86	136	201	274	332	394	462	535	613	696
	Min. Bearing	–	1.5/3	1.5/3	1.5/3	1.5/3	1.5/3.1	1.5/3.6	1.8/4.2	2.2/4.8	2.7/5.5	3.2/6.2
40'	Simple	–	48	79	121	173	238	316	409	518	644	789
	Multiple	–	70	113	168	238	294	350	411	476	546	620
	Min. Bearing	–	1.5/3	1.5/3	1.5/3	1.5/3	1.5/3	1.5/3.4	1.6/4	2/4.6	2.4/5.2	3/5.9

NOTES

- ▶ Both Architectural and Framing appearance classification BOISE GLULAM® beams have the same structural classification, 24F-V4. Appearance classification does not affect the beam's allowable design values.
- ▶ Uniform PLF load values are limited by shear, moment, total load deflection limited to L/180 and live load deflection limited to L/240.
- ▶ Live load is no greater than 0.75 of total load.
- ▶ Table values assume that lateral support is provided at each support and continuously along the compression edge of the beam.
- ▶ Span is measured center to center of the supports.
- ▶ Table values for Minimum Required Bearing Lengths are based on the allowable compression design value perpendicular to grain for the beam and the load value shown. Other design considerations, such as a weaker support material, may warrant longer bearing lengths. Table values assume that support is provided across the full width of the beam.
- ▶ Wind loading has not been considered in this table.
- ▶ Table assumes dry-use conditions.
- ▶ Table was designed to apply to a broad range of applications. It may be possible to exceed the limitations of this table by analyzing a specific application with the BC Calc® software.

BOISE GLULAM Beams Floor and Roof Application Tables

GENERAL NOTES

- ▶ Continuous lateral support at the top of the beam is assumed.
- ▶ Minimum 3" end bearing or see BC Calc® software requirements.
- ▶ Bearing length specifications assume bearing across the full width of the beams and are based upon the glulam's allowable compression perpendicular to grain value.
- ▶ Table assumes uniform loading on worst case of simple or multiple beam span applications for all tables.
- ▶ Longer bearing lengths may be required depending upon support conditions, use BC Calc® sizing software for analysis.
- ▶ Multiple member beams require proper connection schedules.
- ▶ Dry-use conditions are assumed.
- ▶ Wind loading has not been considered in roof tables.
- ▶ It may be possible to exceed the limitations of this table by analyzing a specific application with the BC Calc® software.
- ▶ 3½" and 5½" wide beams with same depth may substitute for 3⅝" and 5⅞" beams, respectively, in the following tables

Ridge Beam (see page 28)

- ▶ Deflection is limited to L/240 live load and L/180 total load.
- ▶ Table based upon either simple or continuous beam span conditions.

Floor Notes (see pages 25, 26, 29)

- ▶ Floor loads are 40 psf live load and 12 psf dead load. Floor live load has been reduced per area provisions in accordance with the model building codes.
- ▶ Floor joist spans may be either simple or continuous. Mid-span support of floor joists may vary up to 4'-0" from centerline of building.
- ▶ Deflection is limited to L/360 live load and L/240 total load, consult governing building code for local provisions.
- ▶ Tables assume a wall load of 100 plf (pages 26 and 29).
- ▶ Interior floor support may vary a maximum of 4 feet from centerline (page 29).

Roof Notes (see pages 27–29)

- ▶ Always use roof live and dead loads that meet or exceed the required design loading.
- ▶ No roof load reductions have been taken.

Header (Roof) (see pages 26 and 29)

- ▶ Deflection is limited to L/240 live load and L/180 total load.
- ▶ Table assumes 2'-0" roof overhang.

One Floor Beam Span Tables

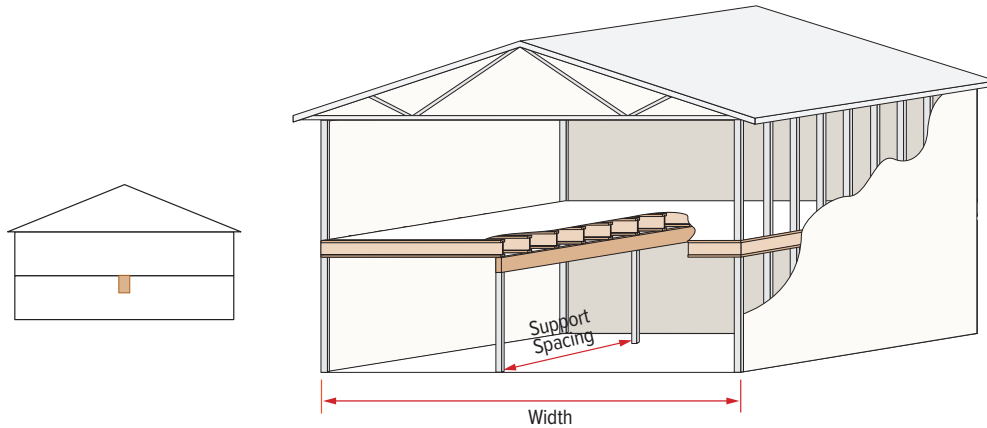

Required Beam Depths and Bearing Lengths (in)

Load Duration	Floor Load (PSF)		Beam Support Spacing	Width of Building Segment											
	Live	Dead		KEY: Beam Breadth (in) x Beam Depth (in)				End Support / Intermediate Support Bearing Length Requirements (in)							
				24'	28'	32'	36'	40'	44'						
100%	40	12	12'	3.125 x 13.5	2.4/5.8	3.125 x 15	2.7/6.8	3.125 x 16.5	3.1/7.7	3.125 x 16.5	3.5/8.7	3.125 x 18	3.9/9.6	3.125 x 18	4.3/10.6
				5.125 x 10.5	1.5/3.6	5.125 x 12	1.7/4.1	5.125 x 12	1.9/4.7	5.125 x 13.5	2.2/5.3	5.125 x 13.5	2.4/5.9	5.125 x 15	2.6/6.5
			14'	3.125 x 16.5	2.7/6.8	3.125 x 18	3.2/7.9	3.125 x 18	3.6/9.0	5.125 x 15	2.5/6.2	5.125 x 16.5	2.8/6.9	5.125 x 16.5	3.1/7.6
				5.125 x 13.5	1.7/4.1	5.125 x 13.5	2.0/4.8	5.125 x 15	2.2/5.5	6.75 x 13.5	1.9/4.7	6.75 x 13.5	2.1/5.2	6.75 x 15	2.3/5.8
			16'	3.5 x 18	3.1/7.7	5.125 x 15	2.2/5.5	5.125 x 16.5	2.5/6.3	5.125 x 16.5	2.9/7.1	5.125 x 18	3.2/7.9	5.125 x 18	3.5/8.6
				5.125 x 15	1.9/4.7	6.75 x 13.5	1.7/4.2	6.75 x 15	1.9/4.8	6.75 x 15	2.2/5.5	6.75 x 15	2.4/6.0	6.75 x 16.5	2.7/6.6
			18'	5.125 x 16.5	2.2/5.3	5.125 x 18	2.5/6.2	5.125 x 18	2.9/7.1	5.125 x 19.5	3.2/8.0	5.125 x 19.5	3.6/8.8	5.125 x 21	3.9/9.7
				6.75 x 15	1.6/4.0	6.75 x 15	1.9/4.7	6.75 x 16.5	2.2/5.4	6.75 x 16.5	2.4/6.0	6.75 x 18	2.7/6.7	6.75 x 18	3.0/7.4
			20'	5.125 x 18	2.3/5.8	5.125 x 19.5	2.8/6.9	5.125 x 19.5	3.2/7.9	5.125 x 21	3.6/8.8	5.125 x 21	4.0/9.8	5.125 x 22.5	4.8/11.9
				6.75 x 16.5	1.8/4.5	6.75 x 16.5	2.1/5.2	6.75 x 18	2.4/6.0	6.75 x 18	2.7/6.7	6.75 x 19.5	3.0/7.5	6.75 x 19.5	3.3/8.2
			22'	5.125 x 19.5	2.6/6.3	5.125 x 21	3.1/7.6	5.125 x 22.5	3.5/8.6	5.125 x 22.5	3.9/9.7	5.125 x 24	4.3/10.8	6.75 x 22.5	3.6/9.0
				6.75 x 18	2.0/4.9	6.75 x 18	2.3/5.8	6.75 x 19.5	2.7/6.6	6.75 x 21	3.0/7.4	6.75 x 21	3.3/8.2		
			24'	5.125 x 21	2.8/6.9	5.125 x 22.5	3.3/8.2	5.125 x 24	3.8/9.4	6.75 x 22.5	3.2/8	6.75 x 22.5	3.6/8.9	6.75 x 24	4.0/9.8
				6.75 x 19.5	2.2/5.4	6.75 x 19.5	2.5/6.3	6.75 x 21	2.9/7.2						

BOISE GLULAM Beams Floor and Roof Application Tables

Two Floor Beam Span Tables

See General Notes on page 25

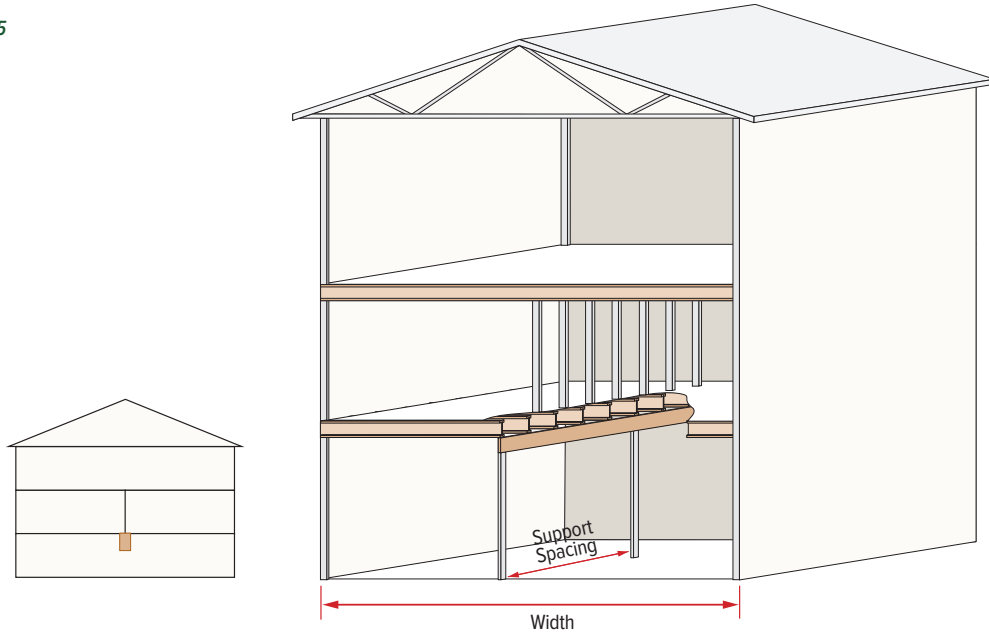

Required Beam Depths and Bearing Lengths (in)

Load Duration	Floor Load (PSF)		Beam Support Spacing	Width of Building Segment											
	Live	Dead		KEY: Beam Breadth (in) x Beam Depth (in)				End Support / Intermediate Support Bearing Length Requirements (in)							
				24'		28'		32'		36'		40'		44'	
100%	40	12	6'	3.125 x 10.5	2.1 / 5.2	3.125 x 12	2.5 / 6.2	3.125 x 12	2.9 / 7.1	3.125 x 13.5	3.2 / 7.9	3.125 x 15	3.5 / 8.7	3.125 x 15	3.8 / 9.5
				5.125 x 9	1.5 / 3.2	5.125 x 9	1.5 / 3.8	5.125 x 9	1.8 / 4.3	5.125 x 10.5	2.0 / 4.8	5.125 x 10.5	2.2 / 5.3	5.125 x 10.5	2.4 / 5.8
			8'	3.125 x 13.5	2.8 / 6.9	3.125 x 15	3.2 / 8	3.125 x 15	3.7 / 9.1	3.125 x 16.5	4.1 / 10.1	3.125 x 18	4.5 / 11.1	5.125 x 13.5	3.0 / 7.3
				5.125 x 10.5	1.7 / 4.2	5.125 x 12	2.0 / 4.9	5.125 x 12	2.3 / 5.6	5.125 x 12	2.5 / 6.2	5.125 x 13.5	2.7 / 6.8	6.75 x 12	2.3 / 5.6
			10'	3.125 x 16.5	3.4 / 8.4	3.125 x 16.5	3.9 / 9.7	5.125 x 15	2.7 / 6.7	5.125 x 15	3.0 / 7.4	5.125 x 16.5	3.3 / 8.1	5.125 x 16.5	3.5 / 8.7
				5.125 x 12	2.1 / 5.2	5.125 x 13.5	2.4 / 6	6.75 x 12	2.1 / 5.1	6.75 x 13.5	2.3 / 5.6	6.75 x 13.5	2.5 / 6.1	6.75 x 15	2.7 / 6.6
			12'	5.125 x 15	2.4 / 6	5.125 x 16.5	2.8 / 6.9	5.125 x 16.5	3.1 / 7.8	5.125 x 18	3.4 / 8.5	5.125 x 18	3.7 / 9.2	5.125 x 19.5	4.0 / 9.8
				6.75 x 13.5	1.9 / 4.6	6.75 x 13.5	2.1 / 5.3	6.75 x 15	2.4 / 5.9	6.75 x 15	2.6 / 6.5	6.75 x 16.5	2.8 / 7	6.75 x 16.5	3.0 / 7.5
			14'	5.125 x 16.5	2.8 / 6.9	5.125 x 18	3.2 / 7.8	5.125 x 19.5	3.5 / 8.7	5.125 x 19.5	3.8 / 9.5	5.125 x 21	4.1 / 10.2	5.125 x 21	4.3 / 10.8
				6.75 x 15	2.1 / 5.2	6.75 x 16.5	2.4 / 6	6.75 x 16.5	2.7 / 6.6	6.75 x 18	2.9 / 7.2	6.75 x 18	3.1 / 7.7	6.75 x 19.5	3.3 / 8.2
			16'	5.125 x 19.5	3.1 / 7.6	5.125 x 21	3.5 / 8.7	5.125 x 21	3.9 / 9.6	5.125 x 22.5	4.2 / 10.4	5.125 x 22.5	4.4 / 11	5.125 x 24	4.7 / 11.6
				6.75 x 16.5	2.4 / 5.8	6.75 x 18	2.7 / 6.6	6.75 x 19.5	2.9 / 7.3	6.75 x 19.5	3.2 / 7.9	6.75 x 21	3.4 / 8.4	6.75 x 21	3.5 / 8.8
			18'	5.125 x 21	3.4 / 8.4	5.125 x 22.5	3.8 / 9.4	5.125 x 24	4.2 / 10.3	5.125 x 24	4.5 / 11.1	6.75 x 22.5	3.6 / 8.9	6.75 x 24	3.9 / 9.8
				6.75 x 19.5	2.6 / 6.4	6.75 x 19.5	2.9 / 7.2	6.75 x 21	3.2 / 7.9	6.75 x 22.5	3.4 / 8.4				

See General Notes on page 25

BOISE GLULAM Beams Floor and Roof Application Tables

Garage Door Header Roof Span Tables

See General Notes on page 25

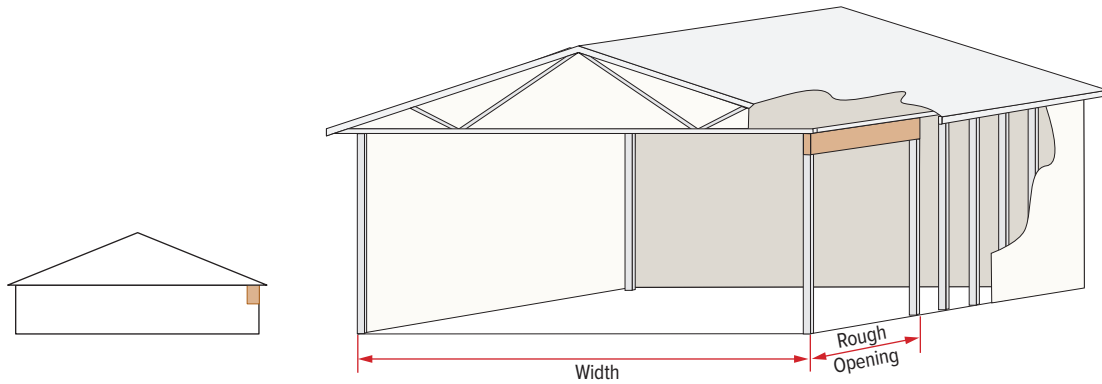

Required Beam Depths and Bearing Lengths (in)

Load Duration	Roof Load (PSF)		Width of Bldg Segment	Clear Span (feet)											
	Live	Dead		KEY: Beam Breadth (in) x Beam Depth (in)						End Support / Intermediate Support Bearing Length Requirements (in)					
				8'-3"		9'-3"		10'-0"		12'-0"		16'-3"		18'-3"	
125%	20	15	24'	3.125 x 6	1.5	3.125 x 7.5	1.5	3.125 x 7.5	1.5	3.125 x 9	1.5	3.125 x 12	2.0	3.125 x 13.5	2.3
				5.125 x 6	1.5	5.125 x 6	1.5	5.125 x 7.5	1.5	5.125 x 7.5	1.5	5.125 x 10.5	1.5	5.125 x 12	1.5
			30'	3.125 x 7.5	1.5	3.125 x 7.5	1.5	3.125 x 9	1.5	3.125 x 10.5	1.8	3.125 x 13.5	2.4	3.125 x 15	2.7
				5.125 x 6	1.5	5.125 x 7.5	1.5	5.125 x 7.5	1.5	5.125 x 9	1.5	5.125 x 12	1.5	5.125 x 12	1.7
			36'	3.125 x 7.5	1.5	3.125 x 9	1.7	3.125 x 9	1.8	3.125 x 10.5	2.1	3.125 x 15	2.9	3.125 x 16.5	3.2
				5.125 x 6	1.5	5.125 x 7.5	1.5	5.125 x 7.5	1.5	5.125 x 9	1.5	5.125 x 12	1.8	5.125 x 13.5	2.0
115%	25	15	24'	3.125 x 7.5	1.5	3.125 x 7.5	1.5	3.125 x 9	1.5	3.125 x 10.5	1.7	3.125 x 13.5	2.3	3.125 x 15	2.6
				5.125 x 6	1.5	5.125 x 6	1.5	5.125 x 7.5	1.5	5.125 x 9	1.5	5.125 x 10.5	1.5	5.125 x 12	1.6
			30'	3.125 x 7.5	1.5	3.125 x 9	1.6	3.125 x 9	1.7	3.125 x 10.5	2.1	3.125 x 15	2.8	3.125 x 16.5	3.1
				5.125 x 6	1.5	5.125 x 7.5	1.5	5.125 x 7.5	1.5	5.125 x 9	1.5	5.125 x 12	1.7	5.125 x 13.5	1.9
			36'	3.125 x 7.5	1.7	3.125 x 9	1.9	3.125 x 10.5	2.0	3.125 x 12	2.4	3.125 x 16.5	3.3	3.125 x 18	3.7
				5.125 x 7.5	1.5	5.125 x 7.5	1.5	5.125 x 7.5	1.5	5.125 x 9	1.5	5.125 x 12	2.0	5.125 x 13.5	2.3
115%	30	15	24'	3.125 x 7.5	1.5	3.125 x 9	1.5	3.125 x 9	1.6	3.125 x 10.5	1.9	3.125 x 13.5	2.6	3.125 x 16.5	2.9
				5.125 x 6	1.5	5.125 x 7.5	1.5	5.125 x 7.5	1.5	5.125 x 9	1.5	5.125 x 12	1.6	5.125 x 13.5	1.8
			30'	3.125 x 9	1.6	3.125 x 9	1.8	3.125 x 10.5	2.0	3.125 x 12	2.3	3.125 x 15	3.1	3.125 x 18	3.5
				5.125 x 6	1.5	5.125 x 7.5	1.5	5.125 x 7.5	1.5	5.125 x 9	1.5	5.125 x 12	1.9	5.125 x 13.5	2.2
			36'	3.125 x 9	1.9	3.125 x 10.5	2.1	3.125 x 10.5	2.3	3.125 x 12	2.7	3.125 x 16.5	3.7	3.125 x 18	4.1
				5.125 x 7.5	1.5	5.125 x 7.5	1.5	5.125 x 9	1.5	5.125 x 10.5	1.7	5.125 x 13.5	2.3	5.125 x 15	2.5
115%	40	15	24'	3.125 x 9	1.6	3.125 x 9	1.8	3.125 x 10.5	2.0	3.125 x 12	2.3	3.125 x 15	3.2	3.125 x 18	3.5
				5.125 x 6	1.5	5.125 x 7.5	1.5	5.125 x 7.5	1.5	5.125 x 9	1.5	5.125 x 12	1.9	5.125 x 13.5	2.2
			30'	3.125 x 9	2.0	3.125 x 10.5	2.2	3.125 x 10.5	2.4	3.125 x 13.5	2.8	3.125 x 16.5	3.8	5.125 x 15	4.3
				5.125 x 7.5	1.5	5.125 x 7.5	1.5	5.125 x 9	1.5	5.125 x 10.5	1.8	5.125 x 13.5	2.3	6.75 x 13.5	2.0
			36'	3.125 x 9	2.3	3.125 x 10.5	2.6	3.125 x 12	2.8	3.125 x 13.5	3.3	3.125 x 18	4.5	5.125 x 16.5	5.0
				5.125 x 7.5	1.5	5.125 x 9	1.6	5.125 x 9	1.7	5.125 x 10.5	2.1	5.125 x 15	2.8	6.75 x 15	2.4

See General Notes on page 25

BOISE GLULAM Beams Floor and Roof Application Tables

Ridge Beam Span Tables

See General Notes on page 25

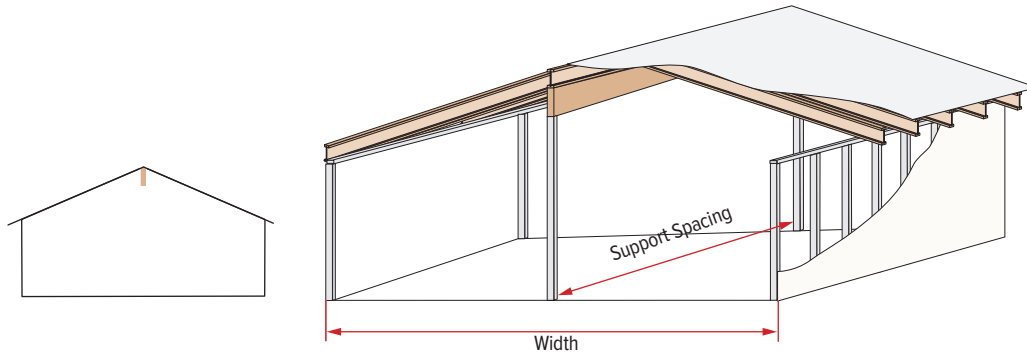

Vertical Holes for Wiring

When designing ridge beams where fixtures may be attached (ceiling fans or lights), a beam may be up-sized in width or depth to accommodate a single vertical hole. For example, if a 3 1/8" x 12" beam is structurally adequate from the table below, a single vertical hole may only be drilled in either a 3 1/8" x 13 1/2" or 5 1/8" x 12" beam in the same application. This provision only applies to the ridge beam table below. A single vertical hole may only be drilled in the middle third of the span, the middle of the beam's cross-section, and be drilled straight in a craftsmanlike manner. Maximum vertical hole diameter is: 1/2" for 3 1/8" wide beams, 3/4" for 5 1/8", 6 3/4" and 8 3/4" beams. For other applications and/or sizes, contact Boise Cascade EWP Engineering.

Required Beam Depths and Bearing Lengths (in)

Load Duration	Roof Load (PSF)		Width of Bldg Segment	Clear Span (feet)							
	Live	Dead		KEY: Beam Breadth (in) x Beam Depth (in)				End Support / Intermediate Support Bearing Length Requirements (in)			
				12'		16'		20'		24'	
125%	20	15	24'	3.125 x 10.5	1.5 / 3.8	3.125 x 13.5	2.0 / 5	3.125 x 16.5	2.5 / 6.2	5.125 x 16.5	1.8 / 4.5
				5.125 x 9	1.5 / 3	5.125 x 10.5	1.5 / 3.1	5.125 x 13.5	1.6 / 3.8	6.75 x 15	1.5 / 3.5
			30'	3.125 x 12	1.9 / 4.7	3.125 x 15	2.5 / 6.2	3.125 x 18	3.1 / 7.8	5.125 x 18	2.3 / 5.7
				5.125 x 9	1.5 / 3	5.125 x 12	1.6 / 3.8	5.125 x 15	1.9 / 4.7	6.75 x 16.5	1.8 / 4.3
			36'	3.125 x 12	2.3 / 5.6	3.125 x 16.5	3.0 / 7.5	5.125 x 16.5	2.3 / 5.7	5.125 x 19.5	2.7 / 6.8
				5.125 x 10.5	1.5 / 3.5	5.125 x 13.5	1.9 / 4.6	6.75 x 15	1.8 / 4.3	6.75 x 18	2.1 / 5.2
115%	25	15	24'	3.125 x 12	1.7 / 4.2	3.125 x 15	2.3 / 5.6	3.125 x 18	2.8 / 7	5.125 x 18	2.1 / 5.1
				5.125 x 9	1.5 / 3	5.125 x 12	1.5 / 3.4	5.125 x 15	1.7 / 4.3	6.75 x 16.5	1.6 / 3.9
			30'	3.125 x 12	2.1 / 5.3	3.125 x 16.5	2.8 / 7	5.125 x 16.5	2.2 / 5.3	5.125 x 19.5	2.6 / 6.4
				5.125 x 10.5	1.5 / 3.2	5.125 x 13.5	1.7 / 4.3	6.75 x 15	1.6 / 4	6.75 x 18	2 / 4.8
			36'	3.125 x 13.5	2.6 / 6.3	3.125 x 18	3.4 / 8.4	5.125 x 18	2.6 / 6.4	5.125 x 22.5	3.1 / 7.6
				5.125 x 10.5	1.6 / 3.9	5.125 x 15	2.1 / 5.1	6.75 x 16.5	2 / 4.8	6.75 x 19.5	2.3 / 5.8
115%	30	15	24'	3.125 x 12	1.9 / 4.7	3.125 x 15	2.5 / 6.2	5.125 x 15	1.9 / 4.7	5.125 x 19.5	2.3 / 5.6
				5.125 x 10.5	1.5 / 3	5.125 x 12	1.5 / 3.8	6.75 x 13.5	1.5 / 3.6	6.75 x 16.5	1.7 / 4.3
			30'	3.125 x 13.5	2.4 / 5.8	3.125 x 18	3.1 / 7.7	5.125 x 18	2.4 / 5.9	5.125 x 21	2.8 / 7
				5.125 x 10.5	1.5 / 3.6	5.125 x 13.5	1.9 / 4.7	6.75 x 15	1.8 / 4.5	6.75 x 18	2.2 / 5.4
			36'	3.125 x 15	2.8 / 7	5.125 x 15	2.3 / 5.7	5.125 x 19.5	2.9 / 7.1	5.125 x 22.5	3.4 / 8.4
				5.125 x 12	1.7 / 4.3	6.75 x 13.5	1.8 / 4.3	6.75 x 16.5	2.2 / 5.4	6.75 x 21	2.6 / 6.4
115%	40	15	24'	3.125 x 13.5	2.3 / 5.6	3.125 x 16.5	3.0 / 7.4	5.125 x 16.5	2.3 / 5.6	5.125 x 21	2.7 / 6.7
				5.125 x 10.5	1.5 / 3.4	5.125 x 13.5	1.8 / 4.5	6.75 x 15	1.7 / 4.3	6.75 x 18	2.1 / 5.1
			30'	3.125 x 15	2.8 / 7	5.125 x 15	2.3 / 5.6	5.125 x 19.5	2.8 / 7	5.125 x 22.5	3.4 / 8.4
				5.125 x 12	1.7 / 4.3	6.75 x 13.5	1.8 / 4.3	6.75 x 16.5	2.2 / 5.3	6.75 x 21	2.6 / 6.4
			36'	3.125 x 16.5	3.4 / 8.4	5.125 x 16.5	2.7 / 6.8	5.125 x 21	3.4 / 8.4	6.75 x 22.5	3.1 / 7.7
				5.125 x 12	2.1 / 5.1	6.75 x 15	2.1 / 5.2	6.75 x 18	2.6 / 6.4		

See General Notes on page 25

BOISE GLULAM Beams Floor and Roof Application Tables

Roof and One Floor Span Tables

See General Notes on page 25

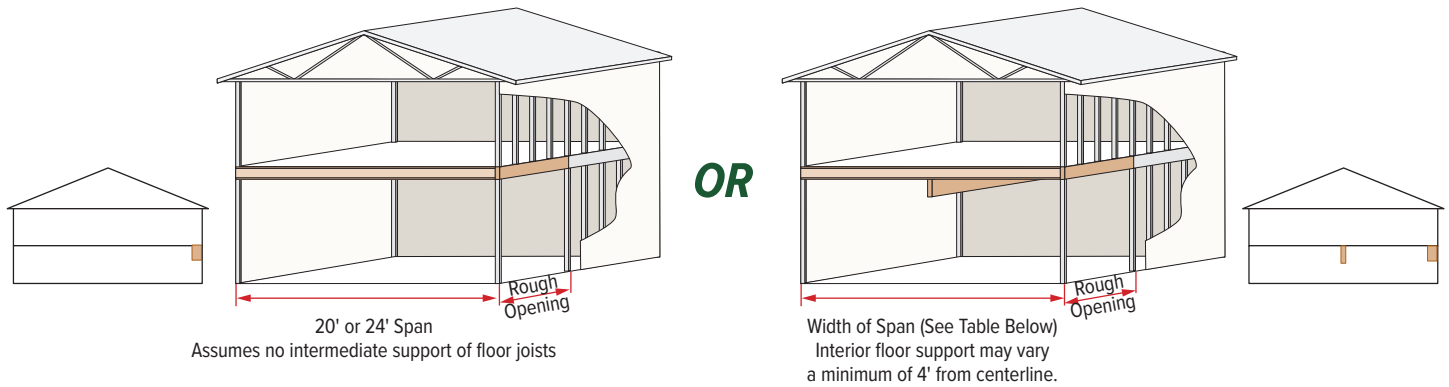

Total load deflection limited to $\frac{5}{16}$ " for window considerations

Required Beam Depths and Bearing Lengths (in)

Load Duration	Roof Load (PSF)		Width of Bldg Segment	Clear Span (feet)					
	Live	Dead		KEY: Beam Breadth (in) x Beam Depth (in)		End Support / Intermediate Support Bearing Length Requirements (in)			
				6'-3"		9'-3"		12'-3"	
125%	20	15	24'	3.125 x 7.5	1.8	3.125 x 12	2.4	3.125 x 16.5	3.1
				5.125 x 6	1.5	5.125 x 10.5	1.5	5.125 x 13.5	1.9
			30'	3.125 x 7.5	1.9	3.125 x 12	2.8	3.125 x 16.5	3.7
				5.125 x 6	1.5	5.125 x 10.5	1.7	5.125 x 13.5	2.3
			36'	3.125 x 7.5	2.2	3.125 x 12	3.2	3.125 x 18	4.2
				5.125 x 6	1.5	5.125 x 10.5	2.0	5.125 x 15	2.6
115%	25	15	24'	3.125 x 7.5	2.0	3.125 x 12	2.5	3.125 x 16.5	3.3
				5.125 x 6	1.5	5.125 x 10.5	1.6	5.125 x 13.5	2.0
			30'	3.125 x 7.5	2.0	3.125 x 12	3.0	3.125 x 18	3.9
				5.125 x 6	1.5	5.125 x 10.5	1.8	5.125 x 15	2.4
			36'	3.125 x 9	2.4	3.125 x 13.5	3.4	3.125 x 18	4.5
				5.125 x 7.5	1.5	5.125 x 10.5	2.1	5.125 x 15	2.8
115%	30	15	24'	3.125 x 9	2.2	3.125 x 12	2.7	3.125 x 16.5	3.5
				5.125 x 6	1.5	5.125 x 10.5	1.7	5.125 x 15	2.2
			30'	3.125 x 9	2.2	3.125 x 12	3.2	3.125 x 18	4.2
				5.125 x 7.5	1.5	5.125 x 10.5	2.0	5.125 x 15	2.6
			36'	3.125 x 9	2.5	3.125 x 13.5	3.7	3.125 x 18	4.8
				5.125 x 7.5	1.6	5.125 x 10.5	2.3	5.125 x 16.5	3.0
115%	40	15	24'	3.125 x 9	2.4	3.125 x 12	3.0	3.125 x 18	4.0
				5.125 x 7.5	1.5	5.125 x 10.5	1.9	5.125 x 15	2.4
			30'	3.125 x 9	2.4	3.125 x 13.5	3.6	3.125 x 18	4.7
				5.125 x 7.5	1.5	5.125 x 10.5	2.2	5.125 x 16.5	2.9
			36'	3.125 x 9	2.8	3.125 x 13.5	4.1	5.125 x 16.5	3.3
				5.125 x 7.5	1.7	5.125 x 12	2.5	6.75 x 15	2.6

See General Notes on page 25

BOISE GLULAM Beams Substitution Tables

Floor Beam Applications (100%) Duration

Steel W Shape Substitution Table

24F-V4 BOISE GLULAM® Equivalent Member

Span	W 6 x 9	W 8 x 10	W 12 x 14	W 12 x 16	W 12 x 19	W 10 x 22	W 12 x 22	W 14 x 22	W 12 x 26	W 14 x 26	W 16 x 26	W 12 x 30
10'	3.125 x 10.5	3.125 x 13.5	3.125 x 18									
	5.125 x 9	5.125 x 10.5	5.125 x 13.5	5.125 x 15	5.125 x 16.5	5.125 x 16.5	5.125 x 18	5.125 x 19.5	5.125 x 21	5.125 x 22.5	5.125 x 24	5.125 x 24
12'	3.125 x 10.5	3.125 x 13.5	3.125 x 18									
	5.125 x 9	5.125 x 10.5	5.125 x 13.5	5.125 x 15	5.125 x 16.5	5.125 x 16.5	5.125 x 18	5.125 x 19.5	5.125 x 21	5.125 x 21	5.125 x 22.5	5.125 x 22.5
14'	3.125 x 10.5	3.125 x 13.5	3.125 x 18									
	5.125 x 9	5.125 x 10.5	5.125 x 13.5	5.125 x 15	5.125 x 16.5	5.125 x 16.5	5.125 x 18	5.125 x 19.5	5.125 x 21	5.125 x 21	5.125 x 22.5	5.125 x 22.5
16'	3.125 x 10.5	3.125 x 13.5	3.125 x 18									
	5.125 x 9	5.125 x 10.5	5.125 x 15	5.125 x 15	5.125 x 16.5	5.125 x 16.5	5.125 x 18	5.125 x 19.5	5.125 x 21	5.125 x 21	5.125 x 22.5	5.125 x 22.5
18'	3.125 x 10.5	3.125 x 13.5	3.125 x 18									
	5.125 x 9	5.125 x 10.5	5.125 x 15	5.125 x 16.5	5.125 x 16.5	5.125 x 16.5	5.125 x 18	5.125 x 19.5	5.125 x 21	5.125 x 21	5.125 x 22.5	5.125 x 22.5
20'	3.125 x 10.5	3.125 x 13.5	3.125 x 18									
	5.125 x 9	5.125 x 10.5	5.125 x 15	5.125 x 16.5	5.125 x 18	5.125 x 16.5	5.125 x 18	5.125 x 19.5	5.125 x 21	5.125 x 21	5.125 x 22.5	5.125 x 22.5
22'	3.125 x 10.5	3.125 x 13.5	3.125 x 18									
	5.125 x 9	5.125 x 10.5	5.125 x 15	5.125 x 16.5	5.125 x 18	5.125 x 16.5	5.125 x 19.5	5.125 x 19.5	5.125 x 21	5.125 x 21	5.125 x 22.5	5.125 x 21
24'	3.125 x 10.5	3.125 x 13.5	3.125 x 18									
	5.125 x 9	5.125 x 10.5	5.125 x 16.5	5.125 x 16.5	5.125 x 18	5.125 x 16.5	5.125 x 19.5	5.125 x 21	5.125 x 21	5.125 x 21	5.125 x 22.5	5.125 x 21
26'	3.125 x 10.5	3.125 x 13.5	3.125 x 18									
	5.125 x 9	5.125 x 10.5	5.125 x 16.5	5.125 x 16.5	5.125 x 18	5.125 x 16.5	5.125 x 19.5	5.125 x 21	5.125 x 21	5.125 x 21	5.125 x 22.5	5.125 x 21
28'	3.125 x 10.5	3.125 x 13.5	3.125 x 18									
	5.125 x 9	5.125 x 10.5	5.125 x 16.5	5.125 x 16.5	5.125 x 18	5.125 x 16.5	5.125 x 19.5	5.125 x 21	5.125 x 21	5.125 x 21	5.125 x 22.5	5.125 x 21
30'	3.125 x 10.5	3.125 x 13.5	3.125 x 18									
	5.125 x 9	5.125 x 10.5	5.125 x 16.5	5.125 x 16.5	5.125 x 18	5.125 x 16.5	5.125 x 19.5	5.125 x 21	5.125 x 21	5.125 x 21	5.125 x 22.5	5.125 x 21
32'	3.125 x 10.5	3.125 x 13.5	3.125 x 18									
	5.125 x 9	5.125 x 10.5	5.125 x 16.5	5.125 x 16.5	5.125 x 18	5.125 x 16.5	5.125 x 19.5	5.125 x 21	5.125 x 21	5.125 x 21	5.125 x 22.5	5.125 x 21
34'	3.125 x 10.5	3.125 x 13.5	3.125 x 18									
	5.125 x 9	5.125 x 10.5	5.125 x 16.5	5.125 x 16.5	5.125 x 18	5.125 x 16.5	5.125 x 19.5	5.125 x 21	5.125 x 21	5.125 x 21	5.125 x 22.5	5.125 x 21
36'	3.125 x 10.5	3.125 x 13.5	3.125 x 18									
	5.125 x 9	5.125 x 10.5	5.125 x 16.5	5.125 x 16.5	5.125 x 18	5.125 x 16.5	5.125 x 19.5	5.125 x 21	5.125 x 21	5.125 x 21	5.125 x 22.5	5.125 x 21
38'	3.125 x 10.5	3.125 x 13.5	3.125 x 18									
	5.125 x 9	5.125 x 10.5	5.125 x 16.5	5.125 x 16.5	5.125 x 18	5.125 x 16.5	5.125 x 19.5	5.125 x 21	5.125 x 21	5.125 x 21	5.125 x 24	5.125 x 21
40'	3.125 x 10.5	3.125 x 13.5	3.125 x 18									
	5.125 x 9	5.125 x 10.5	5.125 x 16.5	5.125 x 16.5	5.125 x 18	5.125 x 16.5	5.125 x 19.5	5.125 x 21	5.125 x 21	5.125 x 21	5.125 x 24	5.125 x 21

NOTES

- ▶ Table intended for preliminary design only. Substitutions should always be approved by the project's design professional of record.
- ▶ Table assumes that original steel W section was sized properly. Loading should always be verified.
- ▶ Table was developed by comparing allowable uniform load capacities due to the worst case control of bending, shear and deflection limits for simple span applications. Beam weights are considered.
- ▶ Deflection limited to L/360 for live load, based upon a live load/total load ratio of 0.8 (residential floor loading 40/10 psf).
- ▶ Steel W Section Allowable Design Values: $F_b = 0.66 \times 36 \text{ ksi}$, $F_v = 0.4 \times 36 \text{ ksi}$, $MOE = 29 \times 10^6 \text{ ksi}$ (allowable stress design assumed).
- ▶ Steel Information — W Section Nomenclature: 1st number = approximate depth (in), 2nd number = weight per foot (lb/ft).
- ▶ 3½" and 5½" wide beams with same depth may substitute for 3⅝" and 5⅝" beams, respectively.

BOISE GLULAM Beams Substitution Tables

Floor Beam Applications (100%) Duration

Douglas Fir–Larch Solid Sawn Substitution Table

24F-V4 BOISE GLULAM® Equivalent Member														
Span	4 x 6		4 x 8		4 x 10		4 x 12		6 x 8		6 x 10		6 x 12	
	Select Structural	No. 1	Select Structural	No. 1	Select Structural	No. 1	Select Structural	No. 1	Select Structural	No. 1	Select Structural	No. 1	Select Structural	No. 1
10'	3.125 x 6	3.125 x 6	3.125 x 7.5	3.125 x 7.5	3.125 x 9	3.125 x 9	3.125 x 9	3.125 x 9	3.125 x 9	3.125 x 9	3.125 x 10.5	3.125 x 10.5	3.125 x 10.5	3.125 x 10.5
										5.125 x 7.5	5.125 x 7.5	5.125 x 9	5.125 x 9	5.125 x 9
12'	3.125 x 6	3.125 x 6	3.125 x 9	3.125 x 7.5	3.125 x 10.5	3.125 x 9	3.125 x 10.5	3.125 x 10.5	3.125 x 9	3.125 x 9	3.125 x 10.5	3.125 x 10.5	3.125 x 12	3.125 x 12
										5.125 x 7.5	5.125 x 7.5	5.125 x 9	5.125 x 9	5.125 x 10.5
14'	3.125 x 6	3.125 x 6	3.125 x 9	3.125 x 7.5	3.125 x 10.5	3.125 x 9	3.125 x 12	3.125 x 10.5	3.125 x 9	3.125 x 9	3.125 x 12	3.125 x 10.5	3.125 x 13.5	3.125 x 12
										5.125 x 7.5	5.125 x 7.5	5.125 x 10.5	5.125 x 9	5.125 x 10.5
16'	3.125 x 6	3.125 x 6	3.125 x 9	3.125 x 7.5	3.125 x 10.5	3.125 x 9	3.125 x 12	3.125 x 10.5	3.125 x 9	3.125 x 9	3.125 x 12	3.125 x 12	3.125 x 13.5	3.125 x 13.5
										5.125 x 7.5	5.125 x 7.5	5.125 x 10.5	5.125 x 10.5	5.125 x 12
18'	3.125 x 6	3.125 x 6	3.125 x 9	3.125 x 7.5	3.125 x 10.5	3.125 x 10.5	3.125 x 12	3.125 x 10.5	3.125 x 9	3.125 x 9	3.125 x 12	3.125 x 12	3.125 x 13.5	3.125 x 13.5
										5.125 x 7.5	5.125 x 7.5	5.125 x 10.5	5.125 x 10.5	5.125 x 12
20'	3.125 x 6	3.125 x 6	3.125 x 9	3.125 x 7.5	3.125 x 10.5	3.125 x 10.5	3.125 x 12	3.125 x 12	3.125 x 9	3.125 x 9	3.125 x 12	3.125 x 12	3.125 x 13.5	3.125 x 13.5
										5.125 x 7.5	5.125 x 7.5	5.125 x 10.5	5.125 x 10.5	5.125 x 12
22'	3.125 x 6	3.125 x 6	3.125 x 9	3.125 x 7.5	3.125 x 10.5	3.125 x 10.5	3.125 x 12	3.125 x 12	3.125 x 9	3.125 x 9	3.125 x 12	3.125 x 12	3.125 x 13.5	3.125 x 13.5
										5.125 x 7.5	5.125 x 7.5	5.125 x 10.5	5.125 x 10.5	5.125 x 12
24'	3.125 x 6	3.125 x 6	3.125 x 9	3.125 x 7.5	3.125 x 10.5	3.125 x 10.5	3.125 x 12	3.125 x 12	3.125 x 9	3.125 x 9	3.125 x 10.5	3.125 x 10.5	3.125 x 13.5	3.125 x 13.5
										5.125 x 7.5	5.125 x 7.5	5.125 x 10.5	5.125 x 10.5	5.125 x 12

NOTES

- ▶ Table intended for preliminary design only. Substitutions should always be approved by the project's design professional of record.
- ▶ Table assumes that original steel solid sawn beam was sized properly. Loading should always be verified.
- ▶ Table was developed by comparing allowable uniform load capacities due to the worst case control of bending, shear, and deflection limits for simple span applications.
- ▶ Deflection limited to L/360 for live load, based upon a live load/total load ratio of 0.8 (residential floor loading 40/10 psf).
- ▶ 3½" and 5½" wide beams with same depth may substitute for 3⅝" and 5⅝" beams, respectively.

BOISE GLULAM Beams Hanger Tables

SIMPSON

Strong-Tie
CONNECTORS

For more information, contact Simpson Strong-Tie at 1-800-999-5099 or strongtie.com

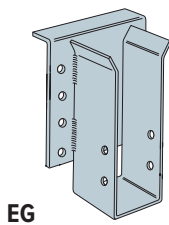

EG

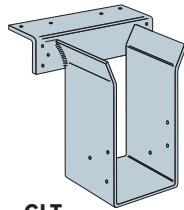

GLT

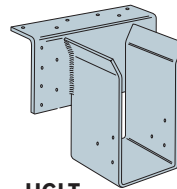

HGLT

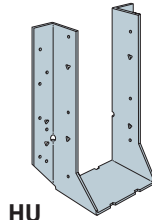

HU

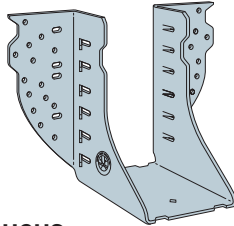

HGUS

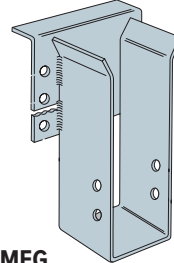

LEG/MEG

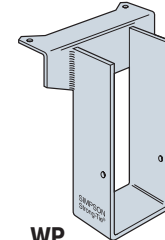

WP

Top Mount Hanger					Face Mount Hanger				
Width	Depth	Hanger Model	Allowable Load (lb)		Width	Depth	Hanger Model	Allowable Load (lb)	
			Uplift (1.6 LD)	Downward Floor (1.0 LD)				Uplift (1.6 LD)	Downward Floor (1.0 LD)
3 1/8"	7 1/2" - 18"	BA3.25X	1,275	4,720	3 1/8"	9" - 10 1/2"	HGUS3.25/10	4,095	9,100
	7 1/2" - 18"	HGLT3	2,450	10,720		12"	HGUS3.25/12	5,205	11,915
3 1/2"	7 1/2" - 18"	BA3.56X	1,275	4,720	3 1/2"	9" - 18"	LGU3.25-SDS	5,555	6,720
	7 1/2" - 18"	HGLT4	2,450	10,720		7 1/2" - 9"	HHUS48	1,780	4,210
5 1/8"	9 1/2" - 18"	HB5.25	2,075	5,395	3 1/2"	7 1/2" - 9"	HGUS48	3,235	7,460
	7 1/2" - 18"	HGLT5	2,450	10,720		10 1/2" - 13 1/2"	HHUS410	3,565	5,635
	12" - 18"	EGQ5.25SDS	7,670	17,105		10 1/2"	HGUS410	4,095	9,100
5 1/2"	9" - 12"	HGUS5.50/10	4,095	9,100	5 1/8"	12"	HGUS412	5,205	11,915
	12"	HU612	1,795	3,275		13 1/2" - 18"	HGUS414	5,360	13,860
	13 1/2"	HHUS5.50/10	3,565	5,635		12" - 18"	HGU3.63-SDS	9,460	13,160
	13 1/2"	HGUS5.50/14	5,515	13,860		10 1/2"	HGUS5.25/10	4,095	9,100
	13 1/2" - 18"	HGU5.62-SDS	5,360	13,735		12"	HGUS5.25/12	5,205	11,915
	9 1/2" - 18"	HB5.50X	2,075	5,395		13 1/2"	HU5.125/13.5	2,695	3,870
	7 1/2" - 18"	HGLT6	2,450	10,720		12" - 18"	HGU5.25-SDS	9,460	13,160
	12" - 18"	EGQ5.62SDS	7,670	17,105		7 1/2"	HU610	1,795	2,680
6 3/4"	9" - 10 1/2"	HGUS6.88/10	4,095	9,100	5 1/2"	9" - 12"	HGUS5.50/10	4,095	9,100
	12"	HGUS6.88/12	5,205	11,915		12"	HU612	1,795	3,275
	13 1/2" - 16 1/2"	HGUS6.88/14	5,360	13,860		13 1/2"	HHUS5.50/10	3,565	5,635
	9 1/2" - 18"	HB6.88X	2,075	5,395		13 1/2"	HGUS5.50/14	5,515	13,860
	7 1/2" - 18"	HGLT7	2,450	10,720		13 1/2" - 18"	HGU5.62-SDS	5,360	13,735
	12" - 18"	EGQ6.88SDS	7,670	17,105		9" - 10 1/2"	HGUS6.88/10	4,095	9,100
	12" - 24"	HGU7.00-SDS	9,460	13,160		12"	HGUS6.88/12	5,205	11,915
	13 1/2" - 24"	HHGU7.00-SDS	14,145	18,480		13 1/2" - 16 1/2"	HGUS6.88/14	5,360	13,860
8 3/4"	7 1/2" - 18"	HGLT9	2,450	10,720	6 3/4"	12" - 24"	HGU7.00-SDS	9,460	13,160
	7 1/2" - 18"	HGLS9	2,265	13,850		13 1/2" - 24"	HHGU7.00-SDS	14,145	18,480
	12" - 24"	HGU9.00-SDS	9,460	13,160		12" - 24"	HGU9.00-SDS	9,460	13,160
	13 1/2" - 24"	HHGU9.00-SDS	14,145	18,480		13 1/2" - 24"	HHGU9.00-SDS	14,145	18,480

NOTES

- Specify hanger height when ordering.
- Loads assume Douglas-fir larch / southern pine header/joist material, adjust for other species.
- Capacities shown are for load durations (LD) listed. Refer to Simpson Strong-Tie Wood Construction Connectors Catalog for load values applicable to other durations of load.
- For additional product information on loading, web stiffeners, nail schedules, and code evaluations, call 1-800-999-5099 or visit their website at www.strongtie.com.

BOISE GLULAM Beams Hanger Tables

MiTek[®]

For more information,
contact
MiTek Structural Connectors
at 1-800-328-5934 or
MiTek-US.com

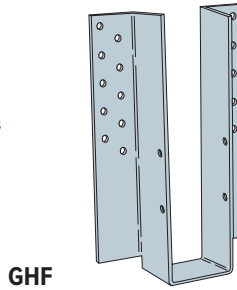

GHF

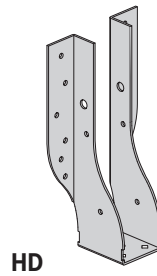

HD

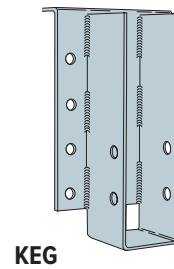

KEG

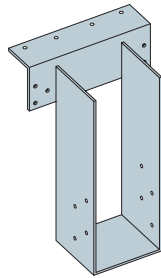

KGLT

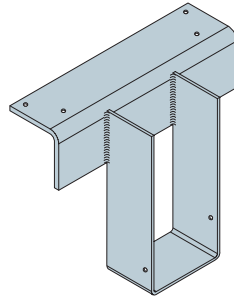

KHW

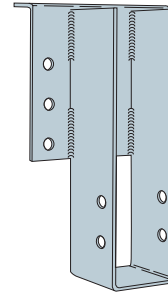

KMEG

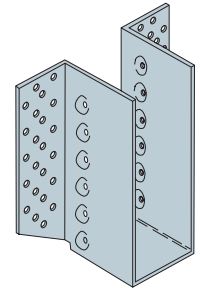

THDH

Top Mount Hanger					Face Mount Hanger				
Width	Depth	Hanger Model	Allowable Load (lb)		Width	Depth	Hanger Model	Allowable Load (lb)	
			Uplift (1.6 LD)	Downward Floor (1.0 LD)				Uplift (1.6 LD)	Downward Floor (1.0 LD)
3 1/8"	7 1/2" – 18"	KHHB3 / KGB3	2,215	6,480	3 1/8"	9" – 10 1/2"	THDH3210	4,345	9,020
	7 1/2" – 18"	KHGLT3	1,935	12,495		12"	THDH3212	5,290	9,710
3 1/2"	7 1/2" – 18"	KHGLT4	1,935	12,495	3 1/2"	9" – 18"	LGU325	3,975	7,135
5 1/8"	7 1/2" – 18"	KHHB5 / KGB5 / KHGB5	2,215	6,480	3 1/2"	9"	THDH48	3,000	7,360
	7 1/2" – 18"	KHGLT5	1,935	12,495		10" – 18"	THDH410	4,345	9,020
	7 1/2" – 18"	KEG5	7,305	17,615		9" – 18"	LGU363	3,975	7,135
7 1/2" – 18"	KHGLT6	1,935	12,495	12" – 18"		HGU3.63	7,375	14,705	
6 3/4"	7 1/2" – 18"	KHHB7 / KGB7 / KHGB7	2,215	6,480	5 1/8"	10 1/2"	HD5112	2,765	3,695
	7 1/2" – 18"	KHGLT7	1,935	12,495		12"	HGU5.25	7,375	14,705
	7 1/2" – 18"	KEG7	9,275	18,695		13 1/2"	HD51135	3,225	4,310
8 3/4"	7 1/2" – 18"	KHGLT9	1,935	12,495		13 1/2"	THDH214-3	5,305	11,325
	7 1/2" – 18"	KEG9	9,305	20,125		12" – 18"	HDQ5212IF	3,280	5,605
						12" – 18"	GHF51178	3,200	10,000
					12" – 18"	HGU525	7,375	14,705	
5 1/2"	13 1/2" – 18"	HGU5.62	7,375	14,705	6 3/4"	9" – 10 1/2"	THD6710	4,345	9,020
6 3/4"	9" – 10 1/2"	THD6712	5,290	9,020		12"	THD6712	5,290	9,020
	13 1/2" – 16 1/2"	THD6714	5,305	11,325		12" – 24"	HGU700	7,375	14,705
	12" – 24"	HGU900	7,375	14,705		8 3/4"	12" – 24"	HGU900	7,375

NOTES

- Specify hanger height when ordering.
- Loads assume Douglas fir–larch / southern pine header/joist material, adjust for other species.
- Capacities shown are for load durations (LD) listed. Refer to USP Full Line Catalog for load values applicable to other durations of load.
- KEG and KMEG load values are for a supporting member with a width of 5 1/2" and 460 psi perpendicular to grain loading in single shear.
- For additional product information on loading, web stiffeners, nail schedules, and code evaluations, call 1-800-328-5934 or visit their website at www.mitek-us.com.

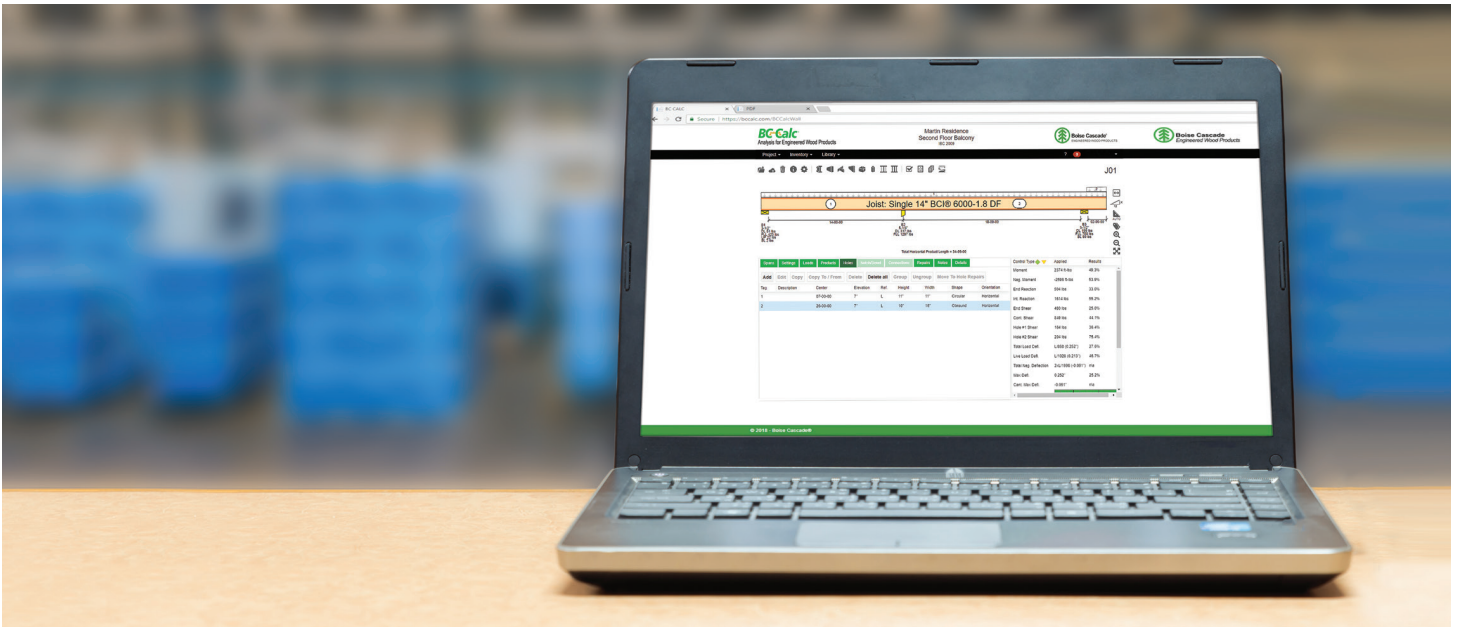

INTEGRATED SOFTWARE FOR EASY SPECIFICATION

All Boise Cascade's engineered wood products are incorporated into Boise Cascade's software suite. BC Framer®, BC Connect®, BC Calc®, and SawTek® all work together, seamlessly integrating design and processing technology into one automated system.

SOFTWARE BENEFITS

- ▶ Design member by member in BC Calc, or create a complete 3D model in BC Framer
- ▶ Dealers can manage projects and material lists and optimize manual or automated saw cut patterns in BC Connect
- ▶ SawTek's processing software cuts, drills, and labels job packs according to your specifications

With Boise Cascade's software suite, there's no need to worry about missing pieces or manual entry errors. The software applications share data digitally, ensuring nothing gets lost or mistyped.

Boise Cascade's software suite is available at www.bc.com/ewp/software/

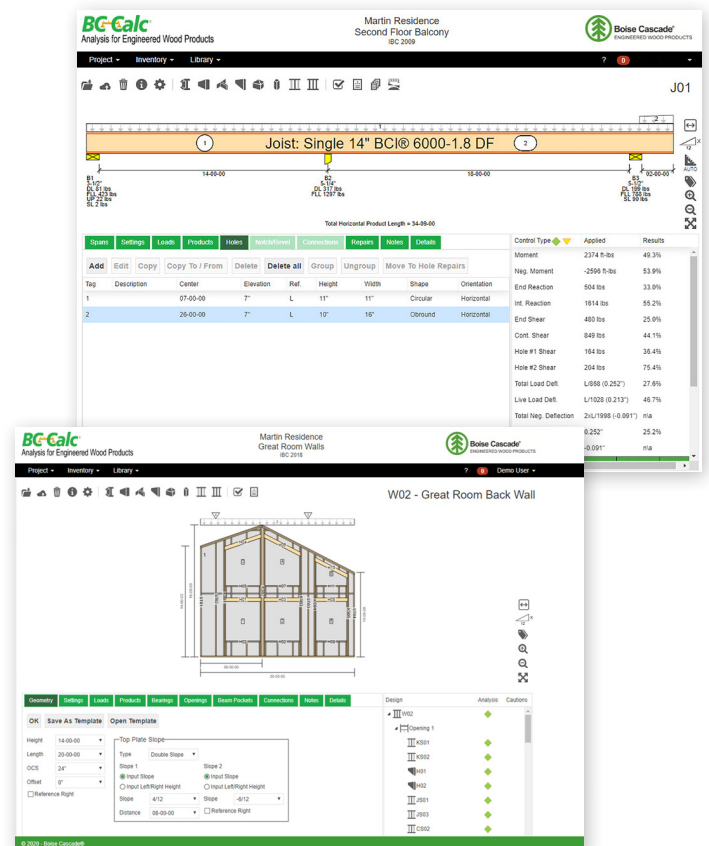

BOISE GLULAM®

From extra-long roof spans to curved beams and common headers to dramatic columns, BOISE GLULAM® gives you the rich, natural look of wood with important benefits engineered in.

With a wide variety of sizes and appearance options, BOISE GLULAM beams are one of the most versatile engineered wood products available. Indoors and out, exposed or concealed, count on BOISE GLULAM as a cost-effective and easy-to-install alternative for beam applications, adding functional beauty to single family, multifamily, and light commercial construction.

BCI® Joists

Straight and strong, yet lightweight and easy to install, our joists give you flat, stable, quiet floors and strong roofs with crisp ridge lines.

Boise Cascade® Rimboard

Offered in long lengths and depths that match BCI® joists, our rim board product installs quickly and saves you time.

Versa-Lam® LVL Beams and Headers

With superior strength and stability, our Versa-Lam® LVL beams are ideal for floors and roofs, and our headers make installing doors and window a snap.

Versa-Stud® Wall Framing

Facing a tall wall challenge? Versa-Stud wall framing has the length, strength and wind resistance you need. It's also ideal for applications where a straight, stiff wall is critical.

BC Calc® Sizing Software

Whether you're a dealer creating material lists or an architect or builder looking to quickly analyze product options, BC Calc® software makes it easy. What's more, this cloud-based application is freely available to everyone and includes a full line of technical support.

When you put it all together, Boise Cascade's Engineered Wood Products (EWP) and software tools make building strong homes easier, faster, and more profitable for home builders.

Limited Lifetime Warranty

Boise Cascade's BOISE GLULAM® and KING BEAM® 3000 products, as listed in APA Product Report PR-L313, are covered by a limited lifetime warranty. View the complete warranty (including limitations and exclusions) at www.BC.com/terms-conditions/sales-terms-and-conditions

Contact Your Local Dealer

NEED MORE INFORMATION?

Visit www.bc.com/ewp/boise-glulam
or call 208-337-3134



Boise Cascade®
WOOD PRODUCTS