



Boise Cascade®
ENGINEERED WOOD PRODUCTS

WESTERN SPECIFIER GUIDE

For Products Manufactured in White City, Oregon



Versa-Lam® LVL 2.1 Design Guide information included - Western US.



The SIMPLE FRAMING SYSTEM® Makes Designing Homes Easier

Architects, engineers and designers trust Boise Cascade's engineered wood products to provide a better system for framing floors, roofs and walls.

It's the SIMPLE FRAMING SYSTEM®, featuring beams, joists and rim boards that work together as a system, so you spend less time cutting and fitting. In fact, the SIMPLE FRAMING SYSTEM® uses fewer pieces and longer lengths than conventional framing, so you'll complete jobs in less time.

You'll Build Better Homes with the SIMPLE FRAMING SYSTEM®

Now it's easier than ever to design and build better floor systems. When you specify the SIMPLE FRAMING SYSTEM®, your clients will have fewer problems with squeaky floors and ceiling gypsum board cracks. The SIMPLE FRAMING SYSTEM® also means overall better floor and roof framing than dimension lumber allows.

Better Framing Doesn't Have to Cost More

Boise Cascade Engineered Wood Products' SIMPLE FRAMING SYSTEM® often costs less

than conventional framing methods when the resulting reduced labor and materials waste are considered. There's less sorting and cost associated with disposing of waste because you order only what you need. Although our longer lengths help your clients get the job done faster, they cost no more.

Environmentally Sound

As an added bonus, floor and roof systems built with BCI® Joists require about half the number of trees as those built with dimension lumber. This helps you design a home both you and future generations will be proud to own.

What Makes the SIMPLE FRAMING SYSTEM® So Simple?

☑ Floor and Roof Framing with BCI® Joists

Light in weight, but heavy-duty, BCI® Joists have a better strength / weight ratio than dimension lumber. Knockouts can be removed for cross-ventilation and wiring.

☑ Ceilings Framed with BCI® Joists

The consistent size of BCI® Joists helps keep gypsum board flat and free of unsightly nail pops and ugly shadows, while keeping finish work to a minimum.

☑ Versa-Lam® LVL Beams for Floor and Roof Framing

These highly-stable beams are free of the large-scale defects that plague dimension beams. The result is quieter, flatter floors (no camber) and no shrinkage-related call-backs.

☑ Boise Cascade® Rimboard

Boise Cascade Engineered Wood Products offer several engineered rimboard products regionally, including Boise Cascade® Rimboard OSB, Boise Cascade® Rimboard, Versa-Rim® Versa-Strand™ 0.8 and Versa-Lam® LVL 1.5 1800 (check supplier or Boise Cascade EWP representative for availability). These products work with BCI® Joists to provide a solid connection at the critical floor/wall intersection.

Product Profiles, BCI® Architectural Specifications	3
About Floor Performance, BCI® Residential Floor Span Tables, One Hour Floor/Ceiling Assembly	4
BCI® Floor Framing Details	5 - 6
BCI® Joist Hole Location & Sizing, Large Rectangular Holes	7
BCI® Cantilever Details, Web Stiffener Requirements	8 - 9
BCI® Floor Load Tables	10 - 12
BCI® Roof Framing Details	13 - 14
BCI® Roof Span Tables	15 - 18
BCI® Roof Load Tables	19 - 23
BCI® Design Properties, BCI® Allowable Nail Spacing	24
Boise Cascade® Rimboard Products/Properties	25

Versa-Lam® LVL Products, Specifications, Allowable Holes	26
Versa-Lam® LVL Details, Multiple Member Connectors	27
Versa-Lam® LVL Floor Load Tables (100% Load Duration)	28
Versa-Lam® LVL Snow Roof Load Tables (115% Load Duration)	29
Versa-Lam® LVL Non-Snow Roof Load Tables (125% Load Duration)	30
Versa-Lam® LVL Closest Allowable Nail Spacing	31
Versa-Lam® LVL Design Values & Allowable Stress Values	31
Versa-Lam® Columns, Versa-Stud®	32
Computer Software: BC Framer®, BC Calc®	33
Framing Connectors: Simpson, Mitek USP	34 - 35
Lifetime Guarantee	Back Cover

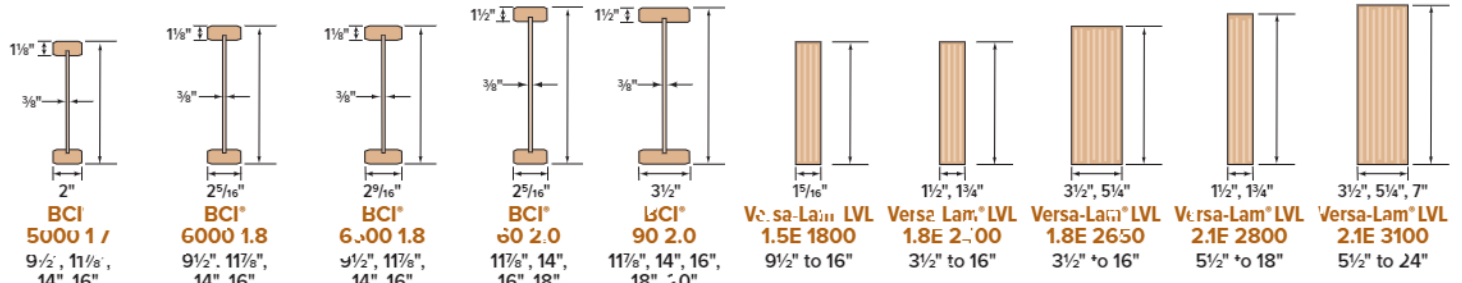

Product depths offered are listed below the product name.

Some products may not be available in all markets. Contact your Boise Cascade EWP representative for availability.

BCI and Versa-Lam LVL products shall be installed in dry climate applications only per their respective ICC-ES ESR evaluation report.



BCI® Joist Architectural Specifications

Scope: This work includes the complete furnishing and installation of all BCI® Joists as shown on the drawings, herein specified and necessary to complete the work.

Materials: BCI® Joists shall be manufactured by Boise Cascade Engineered Wood Products with oriented strand board webs, Versa-Lam® laminated veneer lumber flanges and waterproof, structural adhesives.

Joist webs shall be graded Structural I Exposure 1 by an agency listed by a model code evaluation service. Strands on the face layers of the web panels shall be oriented vertically in the joist. The web panels shall be glued together to form a continuous web member. The web panels shall be machined to fit into a groove in the center of the wide face of the flange members so as to form a pressed glue joint at that junction.

Design: The BCI® Joists shall be sized and detailed to fit the dimensions and loads indicated on the plans. All designs shall be in accordance with allowable values and section properties developed in accordance with ASTM D5055 and listed in the governing code evaluation service's report.

Drawing: Additional drawings showing layout and detail necessary for determining fit and placement in the building are (are not) to be provided by the supplier.

Fabrication: The BCI® Joists and section properties shall be manufactured in a plant evaluated for fabrication by the governing code evaluation service and under the supervision of a third-party inspection agency listed by the corresponding evaluation service.

Storage and Installation: The BCI® Joists, if stored prior to erection, shall be stored in a vertical and level position and protected from the weather. They shall be handled with care so they are not damaged.

The BCI® Joists are to be installed in accordance with the plans and the Boise Cascade Engineered Wood Products Installation Guide. Temporary construction loads which cause stresses beyond design limits are not permitted. Erection bracing shall be provided to keep the BCI® Joists straight and plumb as required and to assure adequate lateral support for the individual BCI® Joists and the entire system until the sheathing material has been applied.

Codes: The BCI® Joists shall be evaluated by a model code evaluation service.

About Floor Performance

Homeowner's expectations and opinions vary greatly due to the subjective nature of rating a new floor. Communication with the ultimate end user to determine their expectation is critical. **Vibration** is usually the cause of most complaints. Installing lateral bridging may help, however, squeaks may occur if not installed properly. Spacing the joists closer together does little to affect the perception of the floor's performance. The most common methods used to increase the performance and reduce vibration of wood floor systems is to

increase the joist depth, limit joist deflections, glue and screw a thicker tongue and groove subfloor, install the joists vertically plumb with level-bearing supports, and install a direct attached ceiling to the bottom flanges of the joists.

The floor span tables listed below offer three very different performance options, based on performance requirements of the homeowner.

Joist Depth	BCI [®] Joist Series	★★★THREE STAR★★★					★★★★FOUR STAR★★★★					CAUTION	★ MINIMUM STIFFNESS ALLOWED BY CODE ★					CAUTION													
		Live Load deflection limited to L/480: The common industry and design community standard for residential floor joists is 3% stiffer than L/360 code minimum. However, floor performance may still be an issue in certain applications, especially with 1 1/2" and 1 3/4" deep joists without a direct attached ceiling.										Live Load deflection limited to L/960+: In addition to providing a floor that is 10% stiffer than the three star floor, field experience has been incorporated into the values to provide a floor with a premium performance level for the more discriminating homeowner										Live Load deflection limited to L/360: Floors that meet the minimum building code L/360 criteria are structurally sound to carry the specified loads; however, there is a much higher risk of floor performance issues. This table should only be used for applications where floor performance is not a concern.									
		12" o.c.	16" o.c.	19.2" o.c.	24" o.c.	32" o.c.	12" o.c.	16" o.c.	19.2" o.c.	24" o.c.	32" o.c.	12" o.c.	16" o.c.	19.2" o.c.	24" o.c.	32" o.c.	12" o.c.	16" o.c.	19.2" o.c.	24" o.c.	32" o.c.										
9 1/2"	5000 1.7	11'-1"	15'-0"	17'-9"	13'-9"	12'-0"	11'-6"	11'-6"	10'-0"	10'-0"	9'-6"	18'-1"	17'-0"	15'-6"	13'-11"	12'-0"															
	6000 1.8	11'-1"	16'-0"	15'-6"	14'-5"	12'-2"	11'-6"	11'-6"	10'-0"	10'-0"	9'-0"	19'-10"	18'-2"	17'-2"	15'-9"	13'-5"															
	1500 1.8	18'-5"	16'-0"	15'-11"	14'-10"	13'-5"	11'-6"	11'-6"	10'-0"	10'-0"	10'-0"	20'-5"	18'-8"	17'-8"	16'-5"	14'-3"															
11 1/8"	5000 1.7	20'-2"	18'-5"	17'-5"	15'-9"	13'-4"	15'-6"	14'-4"	12'-6"	12'-7"	11'-5"	22'-3"	19'-4"	17'-7"	15'-9"	13'-4"															
	6000 1.8	21'-0"	19'-0"	18'-4"	17'-1"	14'-10"	15'-6"	15'-1"	14'-3"	13'-5"	12'-0"	23'-6"	21'-6"	20'-0"	17'-11"	14'-10"															
	1500 1.8	21'-1"	20'-0"	18'-11"	17'-7"	14'-10"	16'-0"	15'-1"	14'-3"	13'-8"	12'-5"	24'-3"	22'-2"	20'-11"	18'-10"	14'-10"															
	60 2.0	23'-3"	21'-3"	20'-1"	18'-8"	16'-4"	18'-0"	16'-1"	15'-7"	14'-6"	13'-2"	25'-9"	23'-6"	22'-3"	20'-9"	16'-4"															
	90 2.0	26'-3"	23'-1"	22'-6"	20'-11"	19'-1"	18'-0"	16'-1"	15'-6"	14'-2"	14'-8"	26'-0"	26'-6"	25'-0"	23'-3"	19'-4"															
14"	5000 1.7	22'-11"	21'-0"	19'-2"	17'-2"	13'-11"	18'-0"	16'-5"	15'-6"	14'-5"	12'-1"	24'-4"	21'-0"	19'-2"	17'-2"	13'-1"															
	6000 1.8	22'-2"	22'-2"	20'-11"	19'-6"	16'-5"	18'-1"	17'-3"	16'-3"	15'-2"	13'-9"	25'-0"	23'-1"	21'-10"	19'-6"	15'-5"															
	1500 1.8	22'-10"	22'-9"	21'-5"	20'-0"	13'-5"	19'-5"	17'-5"	16'-5"	15'-6"	14'-1"	24'-6"	25'-1"	22'-11"	20'-6"	13'-5"															
	60 2.0	26'-5"	24'-2"	22'-9"	21'-3"	16'-4"	20'-8"	18'-0"	17'-9"	16'-5"	14'-11"	26'-3"	26'-8"	25'-3"	22'-10"	16'-4"															
	90 2.0	29'-0"	27'-1"	25'-6"	23'-8"	19'-6"	23'-3"	21'-1"	19'-9"	18'-4"	16'-1"	32'-10"	30'-0"	28'-3"	26'-0"	19'-6"															
16"	6000 1.8	26'-0"	24'-5"	23'-1"	20'-10"	15'-9"	20'-1"	19'-1"	18'-0"	16'-9"	15'-2"	26'-6"	25'-6"	23'-4"	20'-10"	13'-9"															
	1500 1.8	27'-5"	25'-1"	23'-8"	21'-1"	15'-9"	21'-6"	19'-1"	18'-5"	17'-2"	15'-7"	30'-1"	28'-1"	24'-6"	21'-1"	15'-9"															
	60 2.0	29'-3"	26'-8"	25'-1"	21'-10"	16'-4"	22'-10"	20'-0"	19'-7"	18'-2"	16'-4"	32'-1"	29'-6"	27'-4"	23'-10"	16'-4"															
	90 2.0	32'-11"	29'-1"	28'-2"	26'-2"	19'-1"	25'-8"	23'-4"	21'-1"	20'-3"	18'-4"	36'-1"	33'-2"	31'-3"	26'-2"	19'-1"															
18"	90 2.0	35'-11"	32'-8"	30'-0"	28'-1"	21'-10"	28'-1"	25'-5"	23'-1"	22'-2"	20'-0"	39'-8"	36'-2"	33'-1"	31'-9"	23'-10"															
20"	90 2.0	38'-10"	35'-4"	33'-4"	30'-11"	24'-8"	30'-4"	27'-6"	25'-11"	24'-0"	21'-8"	42'-1"	39'-1"	36'-10"	32'-11"	24'-8"															

- Span table is based on a residential floor load of 40 psf live load and 10 psf dead load (12 psf dead load for 90 2.0 joists).
- Span values assume 2 1/2" minimum plywood/OSB rated sheathing is glued and nailed to joists for composite action (joists spaced at 32" o.c. require sheathing rated for such spacing - 5/8" plywood/OSB).
- Span values represent the most restrictive of simple or multiple span applications. Analyze multiple span joists with BC Calc[®] sizing software if the length of any span is less than half the length of an adjacent span.
- Span values are the maximum allowable clear distance between supports

- Table values assume minimum bearing lengths without web stiffeners for joist depths of 16" inches and less (18" & 20" joists require web stiffeners at all bearing locations).
- Floor tile will increase dead load and may require specific deflection limits, contact Boise Cascade EWP Engineering for further information.
- This table was designed to apply to a broad range of applications. It may be possible to exceed the limitations of this table by analyzing a specific application with the BC Calc[®] sizing software.

One-Hour Fire Resistance Assembly

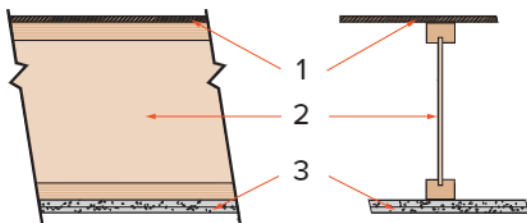

ICC-ES[®]/APA[®] ESR-1336

FIRE ASSEMBLY COMPONENTS

- Min. 2 3/32" thick tongue and groove sheathing (exterior glue), installed with long edge perpendicular to joist length, staggered one joist spacing with adjacent sheets, and glued to joists with construction adhesive.
- BCI[®] Joists at 24" o.c. or less.
- Two layers 5/8" Type X or two layers 1/2" type C gypsum board, installed per Figures 2 or 3 of ICC-ES[®]/APA[®] ESR-1336.

SOUND ASSEMBLY COMPONENTS

When constructed with resilient channel.

- Add carpet & pad to fire assembly;
- Add 3 1/2" glass fiber insulation to fire assembly;
- Add an additional layer of minimum 5/8" sheathing and 3 1/2" glass fiber insulation to fire assembly;

STC=54	IIC=68	or
STC=55	IIC=46	or
STC=61	IIC=50	

See the US version of the Boise Cascade Fire Design & Installation Guide for specific assembly information and other fire resistive options or contact your local Boise Cascade representative.

BCI® Joists

NOTE

The illustration below is showing several suggested applications for the Boise Cascade EWP products. It is not intended to show an actual house under construction.

NO MIDSPAN BRIDGING IS REQUIRED FOR BCI® JOISTS

FOR INSTALLATION STABILITY,
Temporary strut lines (1x4 min.) 8' on center max. Fasten at each joist with 2-8d nails minimum.

Dimension lumber is not suitable for use as a rim board in BCI® joist systems.

F01 F02

BCI® rim joist, see page 5.

F07

Boise Cascade® RimBoard, see pages 6 and 25.

For load bearing cantilever details, see page 9.

F06 F09

BCI® blocking or 2x4 "squash" block on each side required when supporting a load-bearing wall above.

F15

When installing Boise Cascade EWP products with treated wood, use only connector fasteners that are approved for use with the corresponding wood treatment.

Versa-Lam® LVL header or an BCI® header.

1½" knock-out holes at approximately 12" o.c. are pre-punched.

F58

F15

See page 7 for allowable hole sizes and location.

F27A

Versa-Lam® LVL beam.

Endwall blocking as required per governing building code.

BCI® Blocking is required when joists are cantilevered.

BCI® Joists, Versa-Lam® LVL, and ALLJOIST® must be stored, installed and used in accordance with the Boise Cascade EWP Installation Guide, building codes, and to the extent not inconsistent with the Boise Cascade EWP installation guide, usual and customary building practices and standards. Versa-Lam® LVL, ALLJOIST® and BCI® Joists must be wrapped, covered, and stored off of the ground on stickers at all times prior to installation. Versa-Lam® LVL, ALLJOIST® and BCI® Joists are intended

only for applications that assure no exposure to weather or the elements and an environment that is free from moisture from any source, or any pest, organism or substance which degrades or damages wood or glue bonds. Failure to correctly store, use or install Versa-Lam® LVL, ALLJOIST® and BCI® Joist in accordance with the Boise Cascade EWP Installation Guide will void the limited warranty.

SAFETY WARNING

DO NOT ALLOW WORKERS ON BCI® JOISTS UNTIL ALL HANGERS, BCI® RIM JOISTS, RIM BOARDS, BCI® BLOCKING PANELS, X-BRACING AND TEMPORARY 1x4 STRUT LINES ARE INSTALLED AS SPECIFIED BELOW. SERIOUS ACCIDENTS CAN RESULT FROM INSUFFICIENT ATTENTION TO PROPER BRACING DURING CONSTRUCTION. ACCIDENTS CAN BE AVOIDED UNDER NORMAL CONDITIONS BY FOLLOWING THESE GUIDELINES:

- Build a braced end wall at the end of the bay, or permanently install the first eight feet of BCI® Joists and the first course of sheathing. As an alternate, temporary sheathing may be nailed to the first four feet of BCI® Joists at the end of the bay.
- All hangers, BCI® rim joists, rim boards, BCI® blocking panels, and x-bracing must be completely installed and properly nailed as each BCI® Joist is set.
- Install temporary 1x4 strut lines at no more than eight feet on center as additional BCI® Joists are set. Nail the strut lines to the sheathed area, or braced end wall, and to each BCI® Joist with two 8d nails.
- The ends of cantilevers must be temporarily secured by strut lines on both the top and bottom flanges.
- Straighten the BCI® Joists to within ½ inch of true alignment before attaching strut lines and sheathing.
- Remove the temporary strut lines only as required to install the permanent sheathing.
- Failure to install temporary bracing may result in sideways buckling or roll-over under light construction loads.
- Do not stack construction materials (sheathing, drywall, etc) in the middle of BCI® Joist spans, contact Boise Cascade EWP Engineering for proper storage and shoring information.

PRODUCT HANDLING TO AND AT JOB SITES

There are some differences between engineered wood products and traditional lumber products in terms of product handling. Avoid handling and storing BCI® joists in the flat direction. Versa-Lam® LVL is dense, and due to the coating applied to the surface, can be more apt to sliding. Please consider these differences when transporting and handling engineered wood products.



Additional floor framing details available with BC Framer® software

END BEARING DETAILS

F07

Nail Boise Cascade® Rimboard to BCI® Joists with 8d nail into each flange.

Dimension lumber is not suitable for use as rim board with BCI® Joists.

F07A

Dimension lumber is not suitable for use as rimboard with BCI® Joists.

Blocking may be required perpendicular to wall, consult design professional of record and/or local building official.

F02

BCI® rim joist.

Use of BCI® rimjoist requires 2x6 wall for minimum joist bearing.

F01

BCI® Joist blocking.

F27A

Top Flange or Face Mount Joist Hanger

Versa-Lam® LVL

F52

One 8d nail each side at bearing

1/2" minimum bearing length

To limit splitting flange, start nails at least 1/2" from end. Nails may need to be driven at an angle to limit splitting of bearing plate.

F08

Solid block all posts from above to bearing below.

F03

Boise Cascade® Rimboard

NOTE: BCI® floor joist must be designed to carry wall above when not stacked over wall below.

Blocking required underneath braced wall panels and shear walls, consult design professional of record.

INTERMEDIATE BEARING DETAILS

F06

For load bearing wall above (stacked over wall below).

BCI® Joist blocking.

F09

Blocking may be required at intermediate bearing for floor diaphragm per IRC in high seismic areas, consult local building official.

Load bearing wall above (stacked over wall below)

2x block.

1/16"

*See info for Double Squash Block Vertical Load [lb/ft]

F28

Intermediate Bearing.

Cross bracing OK as blocking only if support below it: not a braced wall panel or shear wall and nail exists above.

F05

Structural Panel reinforcement (when required).

BCI® Joist blocking required for cantilever.

For load bearing cantilever, see pages 8 and 9. Uplift on backspan shall be considered in all cantilever designs.

F10

Backer block (minimum 12" wide). Nail with 10-10d nails.

Joist Hanger

Filler block. Nail with 10-10d nails.

Backer block required where top flange joist hanger load exceeds 250 lbs. Install tight to top flange.

F58

Double BCI Joist Connection

Filler Block (if required) See Title "J-13" or requirements.

Web Filler: Nailing See TN J-13 for joist specific schedule.

- Filler block not required when all loads are to, loaded and applied to each plate except BCI® 90 and AJS® 2.5, 3.0.
- Side loads and/or uneven top loads require filler block. See Boise Cascade Technical Note J-13 for further information.
- Fasten floor sheathing to each plate, per diaphragm nailing schedule.

F14

BCI® Joist Slope Cut Reinforcement

Detail below is to original drawing. BCI® Joist shall not be used as a collar or rafter tension tie

2x6 min. center. Joist shall be supported by ridge beam or other upper bearing support

Heel Depth (see table below) 6 min, 12, 24, 1 1/2" min. x BCI depth

BCI® Joist Slope Cut Reinforcement

Detail below is to original drawing. BCI® Joist shall not be used as a collar or rafter tension tie

2x6 min. center. Joist shall be supported by ridge beam or other upper bearing support

Heel Depth (see table below) 6 min, 12, 24, 1 1/2" min. x BCI depth

End Wall Bearing	Minimum Heel Depth					
	6/12	7/12	8/12	9/12	10/12	12/12
2 x 4	4 3/8"	4 5/8"	4 3/4"	4 3/4"	4 3/4"	4 3/4"
2 x 6	3 3/8"	3 7/8"	2 5/8"	2 3/4"	2 7/8"	2 1/4"

2x blocking required at bearing (not shown for Joist). 2x6 min. wood OSB tied sheathing as reinforcement. Install reinforcement in the gap horizontal. Install on both sides of the joist, tight to bottom flange. Leave minimum 1/4" gap between reinforcement and bottom of top flange. Apply construction adhesive to contact surfaces and fasten with rows or min. 10d box nails at 6" o.c. Alternate nailing from each side and clinch.

LATERAL SUPPORT

- BCI® Joists shall be laterally supported at the ends with headers, rim board, BCI® rim joist or blocking panels. BCI® blocking panels or rimboard are required at cantilever supports.
- Blocking may be required at intermediate bearings for floor diaphragm per IRC® in high seismic areas, consult local building official.

MINIMUM BEARING LENGTH FOR BCI® JOISTS

- Minimum end bearing: 1/2" for all BCI® Joists. 3/2" is required at cantilever and intermediate supports.
- Longer bearing lengths allow higher reaction values. Refer to the building code evaluation report or the BCI® software.

NAILING REQUIREMENTS

- BCI® rim joist, rim board or closure panel to BCI® joist:
 - Rims or closure panel 1 1/2 inches thick and less: 2-8d nails, one each in the top and bottom flange.
 - BCI® 5000 rim joist: 2-10d box nails, one each in the top and bottom flange.
 - BCI® 6000/60 rim joist: 2-15d box nails, one each in the top and bottom flange.
 - BCI® 6500/90 rim joist: Toe-nail top flange to rim joist with 2-10d box nails, one each side of flange.
- BCI® rim joist, rim board or BCI® blocking panel to support:
 - Min. 8d nails @ 6" o.c. per IRC®.
 - Connection per design professional of record's specification for shear transfer.
- BCI® joist to support:
 - 2-8d nails, one on each side of the web, placed 1 1/2 inches minimum from the end of the BCI® Joist to limit splitting.
- Sheathing to BCI® joist:
 - Prescriptive residential floor sheathing nailing: refer to Boise Cascade R6L-2(1).

- See Section 5. Allow tie nails, acting in tension, to be placed in floor diaphragm nailing specified at closer spacing than IRC®. Maximum blocking spacing for full lateral stability: 18" for BCI® 5000, 24" for larger BCI joist series.
- 14 gauge staples may be substituted for 8d nails if the staples penetrate at least 1 inch into the joist.
- Wood screws may be acceptable, contact local building official and/or Boise Cascade EWP Engineering for further information.

BACKER AND FILLER BLOCK DIMENSIONS

Series	Backer Block Thickness	Filler Block Thickness
5000 1.7	3/4" or 1/2" wood panels	1/2" wood panels or 2 x 4
6000 1.8	1 1/8" or two 1/2" wood panels	2 x 4 + 7/8" or 1 1/2" wood panel
6500 1.8	1 1/8" or two 3/4" wood panels	2 x 4 + 3/4" or 3/4" wood panel
60 2.0	1 1/8" or two 1/2" wood panels	2 x 4 + 7/8" or 1 1/2" wood panel
90 2.0	2 x lumber	double 2 x lumber

- Cut backer and filler blocks to a maximum depth equal to the web depth: 1/4" to avoid a forced fit.

***Detail F 9 Table Double Squash Block Vertical Load [lb/ft]**

Series	Joist Spacing [in]			
	12	16	19.2	24
2x4	4460	3347	2700	2231
2x6	7013	5259	4303	3500

- Squash blocks are to be in full contact with upper floor and lower wall plate.
- Capacities shown are for a double squash blocks at each joist, SPF or better.

WEB STIFFENER REQUIREMENTS

- See *Web Stiffener Requirements* on page 9.
- PROTECT BCI® JOISTS FROM THE WEATHER**
- BCI® Joists are intended only for applications that provide permanent protection from the weather. Bundles of product should be covered and stored off of the ground on stickers.

BCI® RIM JOISTS AND BLOCKING

Depth [in]	Series	Vertical Load Capacity (plf)	
		No W.S. ⁽¹⁾	W.S. ⁽²⁾
9 1/2"	5000 1.7, 6000 1.6, 6500 1.8	2300	N/A
	5000 1.7, 6000 1.6, 6500 1.8	2150	N/A
11 1/8"	60 1.0, 90 2.0	2500	N/A
	6000 1.7, 6000 1.8, 6500 1.3	2000	N/A
14"	60 2.0, 90 2.0	2400	N/A
	6000 1.8, 6000 1.3	900	2500
16"	60 2.0, 90 2.0	2300	2700
	60 2.0, 90 2.0	N/A	2700
18"	90 2.0	N/A	2700

- No web stiffeners required.
 - Web stiffeners required at each end of blocking, values not applicable for rim joists.
- N/A: Not applicable

BCI® Joists are manufactured with 1/2" round perforated knockouts in the web at approximately 12" on center

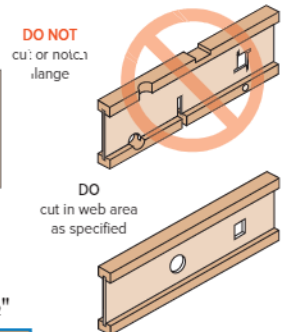
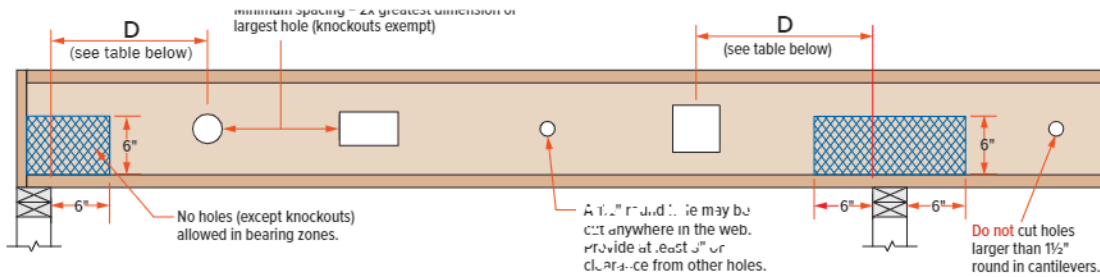

Minimum distance from support, listed in table below, is required for all holes greater than 1/2"

MINIMUM DISTANCE (D) FROM ANY SUPPORT TO THE CENTERLINE OF THE HOLE																
Round Hole Diameter [in]		2	3	4	5	6	7	8	8 7/8	10	11	12	13	14	15	
Rectangular Hole Side [in]		-	-	-	3	4	7	-	-	-	-	-	-	-	-	
Any 9 1/2" Joist	Span [ft]	8	1'-0"	1'-1"	1'-8"	2'-3"	2'-11"	3'-7"								
		12	1'-0"	1'-7"	2'-7"	3'-6"	4'-5"	5'-11"								
		16	1'-0"	2'-2"	3'-5"	4'-8"	5'-11"	7'-2"								
Round Hole Diameter [in]		2	3	4	5	6	7	8	8 7/8	10	11	12	13	14	15	
Rectangular Hole Side [in]		-	-	-	3	4	5	7	8	-	-	-	-	-	-	
Any 11 1/8" Joist	Span [ft]	8	1'-0"	1'-1"	1'-6"	2'-0"	2'-5"	2'-11"	3'-5"	3'-10"						
		12	1'-0"	1'-7"	2'-3"	3'-0"	3'-8"	4'-3"	5'-1"	5'-9"						
		16	1'-0"	2'-1"	3'-0"	4'-0"	4'-11"	5'-10"	6'-10"	7'-8"						
		20	1'-5"	2'-7"	3'-10"	5'-0"	6'-2"	7'-2"	8'-6"	9'-7"						
Round Hole Diameter [in]		2	3	4	5	6	7	8	8 7/8	10	11	12	13	14	15	
Rectangular Hole Side [in]		-	-	-	-	2	3	5	6	8	9	-	-	-	-	
Any 1" Joist	Span [ft]	8	1'-0"	1'-1"	1'-2"	1'-2"	1'-6"	1'-11"	2'-4"	2'-9"	3'-3"	3'-8"				
		12	1'-0"	1'-1"	1'-2"	1'-7"	2'-3"	2'-11"	3'-6"	4'-1"	4'-10"	5'-6"				
		16	1'-0"	1'-1"	1'-3"	2'-2"	3'-0"	3'-10"	4'-9"	5'-6"	6'-6"	7'-2"				
		20	1'-0"	1'-1"	1'-7"	2'-8"	3'-9"	4'-10"	5'-11"	6'-10"	8'-1"	9'-2"				
		24	1'-0"	1'-1"	1'-11"	3'-3"	4'-6"	5'-10"	7'-1"	8'-3"	9'-9"	11'-0"				
Round Hole Diameter [in]		2	3	4	5	6	7	8	8 7/8	10	11	12	13	14	15	
Rectangular Hole Side [in]		-	-	-	-	2	3	5	6	8	9	10	11	-	-	
Any 16" Joist	Span [ft]	8	1'-0"	1'-1"	1'-2"	1'-2"	1'-3"	1'-3"	1'-7"	1'-11"	2'-4"	2'-9"	3'-2"	3'-7"		
		12	1'-0"	1'-1"	1'-2"	1'-2"	1'-3"	1'-9"	2'-4"	2'-11"	3'-7"	4'-2"	4'-9"	5'-4"		
		16	1'-0"	1'-1"	1'-2"	1'-2"	1'-7"	2'-0"	3'-2"	3'-10"	4'-9"	5'-7"	6'-4"	7'-2"		
		20	1'-0"	1'-1"	1'-2"	1'-2"	2'-0"	3'-0"	4'-0"	4'-10"	5'-11"	6'-11"	7'-11"	8'-11"		
		24	1'-0"	1'-1"	1'-2"	1'-3"	2'-5"	3'-7"	4'-9"	5'-10"	7'-2"	8'-2"	9'-6"	10'-9"		
Round Hole Diameter [in]		2	3	4	5	6	7	8	8 7/8	10	11	12	13	14	15	
Rectangular Hole Side [in]		-	-	-	-	-	-	2	3	5	6	7	9	10	11	
BC® 90 Joist	Span [ft]	12	1'-0"	1'-1"	1'-2"	1'-2"	1'-5"	1'-11"	2'-4"	2'-9"	3'-3"	3'-9"	4'-2"	4'-8"	5'-1"	5'-7"
		16	1'-0"	1'-1"	1'-2"	1'-4"	1'-11"	2'-7"	3'-2"	3'-8"	4'-5"	5'-0"	5'-7"	6'-3"	6'-10"	7'-0"
		20	1'-0"	1'-1"	1'-2"	1'-8"	2'-5"	3'-3"	4'-0"	4'-8"	5'-6"	6'-3"	7'-0"	7'-9"	8'-7"	9'-4"
		24	1'-0"	1'-1"	1'-2"	2'-0"	2'-11"	3'-10"	4'-9"	5'-7"	6'-7"	7'-6"	8'-5"	9'-4"	10'-3"	11'-2"
		28	1'-0"	1'-1"	1'-4"	2'-0"	3'-5"	4'-6"	5'-7"	6'-6"	7'-9"	8'-9"	9'-10"	10'-11"	12'-0"	13'-1"
Round Hole Diameter [in]		2	3	4	5	6	7	8	8 7/8	10	11	12	13	14	15	
Rectangular Hole Side [in]		-	-	-	-	-	-	-	2	3	5	6	7	8	10	
20' BC® 90 Joist	Span [ft]	12	1'-0"	1'-1"	1'-2"	1'-2"	1'-3"	1'-6"	1'-11"	2'-3"	2'-9"	3'-2"	3'-7"	3'-11"	4'-4"	4'-9"
		16	1'-0"	1'-1"	1'-1"	1'-2"	1'-6"	2'-1"	2'-7"	3'-1"	3'-8"	4'-3"	4'-9"	5'-3"	5'-10"	6'-4"
		20	1'-0"	1'-1"	1'-2"	1'-3"	1'-11"	2'-7"	3'-3"	3'-10"	4'-7"	5'-3"	5'-11"	6'-7"	7'-4"	8'-0"
		24	1'-0"	1'-1"	1'-2"	1'-6"	2'-4"	3'-1	3'-11"	4'-7"	5'-6"	6'-4"	7'-2"	7'-11"	8'-9"	9'-7"
		28	1'-0"	1'-1"	1'-2"	1'-5"	2'-8"	3'-8"	4'-7"	5'-5"	6'-6"	7'-0"	8'-4"	9'-3"	10'-3"	11'-2"

- Select a table row based on joist depth and the actual joist span rounded up to the nearest table span. Scan across the row to the column headed by the appropriate round hole diameter or rectangular hole side. Use the longest side of a rectangular hole. The table value is the closest that the centerline of the hole may be to the centerline of the nearest support.
- The entire web may be cut out. **DO NOT** cut the flanges. Holes apply to either single or multiple joists in repetitive member conditions.
- For multiple holes, the amount of uncut web between holes must equal at least twice the diameter (or longest side) of the largest hole.
- 1/2" round knockouts in the web may be removed by using a short piece of metal pipe and hammer.
- Holes may be positioned vertically in the web, provided they don't extend into either flange.
- This table was designed to apply to design conditions covered by uniform load PLT tables only, shown elsewhere in this publication. Use BC Calc® software to check other hole sizes or holes under other design conditions, including joists supporting concentrated loads. It may be possible to exceed the limitations of this table by analyzing a specific application with the BC Calc® software.

Large Rectangular Holes in BCI® Joists

Hole size table based on maximum uniform load of 40 psf live load and 10 psf dead load, at maximum spacing of 24" on-center.

Single Span Joist

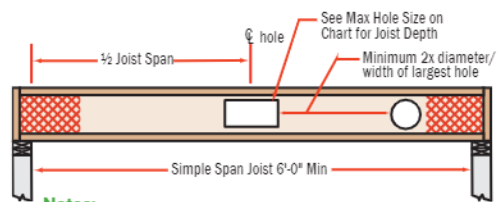

Notes:
Additional holes may be cut in the web provided they meet the specifications as shown in the hole distance chart shown above or as allowed using BC Calc sizing software

Joist Depth	Maximum Hole Size	
	Simple Span	Multiple Span
9 1/2"	6' x 14"	6' x 12"
11 1/8"	7' x 16' 8' x 15"	8' x 12"
14"	9' x 16' 10' x 15'	8' x 15"
16"	9' x 13' 11' x 16'	10' x 14"

Multiple Span Joist

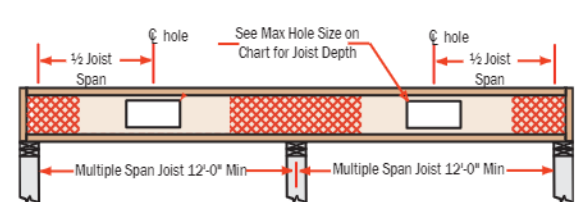

Larger holes may be possible for either single or multiple span joists; use BC Calc® sizing software for specific analysis.

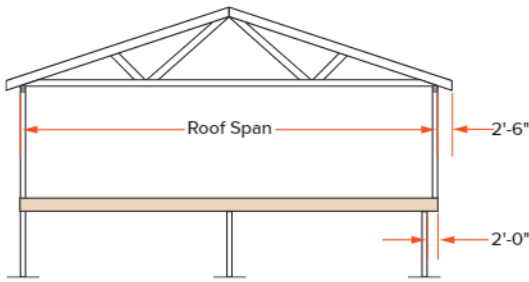

PLYWOOD / OSB REINFORCEMENT (If Required per Table on page 8 or BC Calc® Analysis)

2³/₃₂" Min. x 48" long plywood / OSB rated sheathing must match the full depth of the BCI® Joist. Nail to the BCI® Joist with 8d nails at 6" o.c. and nail with 4-8d nails into backer block. When reinforcing both sides, stagger nails to limit splitting. Always with horizontal face grain.

The tables on page 8 assume a wall weight of 100 plf, in addition to the roof loading shown. Applications with loading that exceeds the loads shown shall be analyzed with BC Calc® software.

- These requirements assume a 100 PLF wall load. Additional support may be required for other loadings, see BC Calc® software.

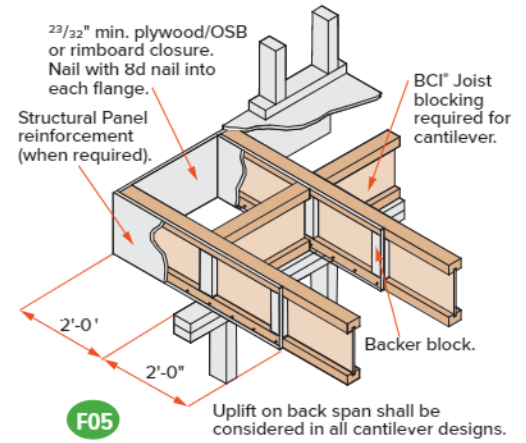

- The tables and details on pages 8 and 9 indicate the type of reinforcements, if any, that are required for load bearing cantilevers up to a maximum length of 2'-0". Cantilevers longer than 2'-0" cannot be reinforced. However, longer cantilevers with lower loads may be allowable without reinforcement. Analyze specific applications with the BC Calc® software.

Non-Load Bearing Wall Cantilever Details

BCI® Joists are intended only for applications that provide permanent protection from the weather. Impervious moisture barrier systems shall be detailed and installed in details F15A and F15B in accordance with 2018 BCI® Sections 107.2.5 and 107.2.6.

Fasten the 2x8 minimum to the BCI® Joist by nailing through the backer block and joist web with 2 rows of 10d nails at 6" on-center. Clinch all nails. For BCI® 90 joists, nail each side with 2 rows (4 rows total) of 16d nails at 6" on-center.

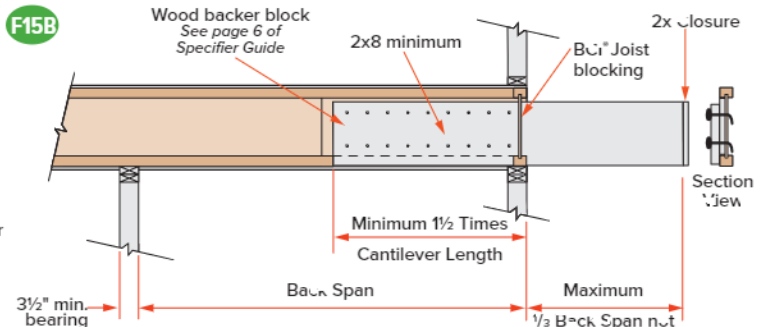
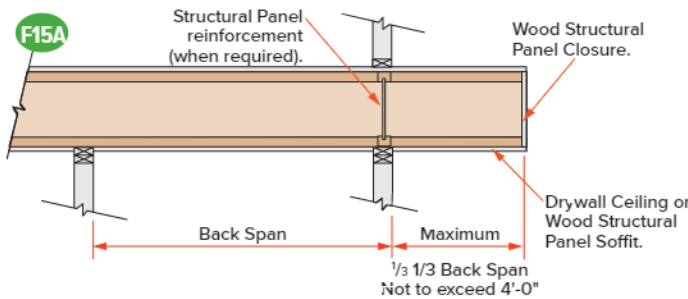

- Analyze BCI® Joist cantilever condition with BC Calc® software

- Loading shall not exceed 60 psf if eave load and 10 psf dead load. At least three joist members shall be present and spaced at 24" o.c. or less.
- Lumber joist shall be No. 2 Dense Southern Pine, No. 1 or 2 Spruce, No. 2 Hem-Fir, or No. 2 Douglas fir, or higher grade.
- Provide positive drainage, durable materials, and venting as required in 2018 IBC Sections 2304.12.2.5 and 2304.12.2.6. Lumber joist shall be sloped.

Web Stiffener Requirements

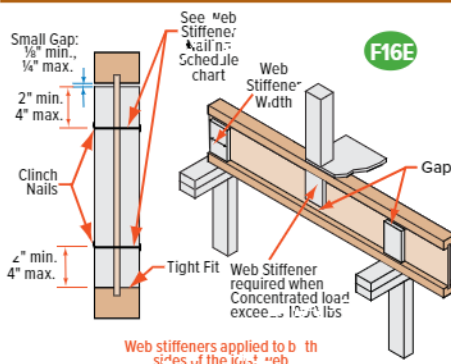

NOTES

- Web stiffeners are optional except as noted below.
- Web stiffeners are always required for all 16" and 20" BCI® joists at all bearing locations.
- Web stiffeners are always required in hanger applications not supported by the top flange of the BCI® Joist. Web stiffeners may be required with certain sloped or skewed hangers or to achieve uplift values. Refer to the hanger manufacturer's installation requirements.
- Web stiffeners are always required in certain roof applications. See Roof Framing Details on page 11.
- Web stiffeners are always required under concentrated loads that exceed 1000 pounds. Install the web stiffeners snug to the top flange in this situation. Follow the nailing schedule for intermediate bearings.
- Web stiffeners may be cut from structural rated wood panels, engineered rimboard or 2x lumber (BCI® 90 only).
- For Structural Capacity: Web stiffeners needed to increase the BCI® Joist's reaction capacity at a specific bearing location.
- Lateral restraint in hanger: Web stiffeners required when hanger does not laterally support the top flange (e.g., adjustable height hangers). Web stiffeners may be of multiple thickness (e.g. BCI® 5500, double 1/2" panel 0').
- Web stiffeners may be used to increase allowable reaction values. See BCI® Design Properties on page 24 or the BC Calc® software.

Web Stiffener Specifications			
BCI® Joist Series	For Structural Capacity (Min. Thickness)	Lateral Restraint in Hanger	Minimum Width
5000 1.7	5/8"	3/4"	2 ⁵ / ₁₆ "
6000 1.8	3/4"	7/8"	2 ⁵ / ₁₆ "
5500 1.8	3/4"	1" or 1 ¹ / ₈ "	2 ⁵ / ₁₆ "
60 2.0	3/4"	7/8"	2 ⁵ / ₁₆ "
90 2.0	2.4 lumber (vertical)		

Web Stiffener Nailing Schedule			
BCI® Joist Series	Joist Depth	Bearing Location	
		End	Intermediate
5000 1.7	9 ¹ / ₂ "	2-8d	2-8d
	11 ⁷ / ₈ "	2-8d	3-8d
	1 ¹ / ₂ "	2-8d	5-8d
	16"	2-8d	6-8d
6000 1.8	9 ¹ / ₂ "	2-8d	2-8d
	11 ⁷ / ₈ "	2-8d	3-8d
	1 ¹ / ₂ "	2-8d	5-8d
	16"	2-8d	6-8d
6500 1.8	9 ¹ / ₂ "	2-8d	2-8d
	11 ⁷ / ₈ "	2-8d	3-8d
	1 ¹ / ₂ "	2-8d	5-8d
	16"	2-8d	6-8d
60 2.0	11 ⁷ / ₈ "	2-8d	3-8d
	14"	2-8d	5-8d
	16"	2-8d	6-8d
90 2.0	11 ⁷ / ₈ "	3-16d	3-16d
	14"	5-16d	5-16d
	15"	6-16d	6-16d
	18"	7-16d	7-16d
	20"	8-16d	8-16d

Allowable Uniform Floor Load (in pounds per lineal foot [PLF])

100% Load Duration

Span Length	BCI® 5000 1.7 Series 2" Flange Width						BCI® 6000 1.8 Series 2 ⁵ / ₁₆ " Flange Width							
	9 ¹ / ₂ " BCI® 5000 1.7		11 ⁷ / ₈ " BCI® 5000 1.7		14" BCI® 5000 1.7		9 ¹ / ₂ " BCI® 6000 1.8		11 ⁷ / ₈ " BCI® 6000 1.8		14" BCI® 6000 1.8		16" BCI® 6000 1.8	
	Live Load	Total Load	Live Load	Total Load	Live Load	Total Load	Live Load	Total Load	Live Load	Total Load	Live Load	Total Load	Live Load	Total Load
6	-	280	-	300	-	313	-	320	-	333	-	346	-	353
7	-	240	-	257	-	268	-	274	-	285	-	297	-	302
8	-	210	-	225	-	235	-	240	-	250	-	260	-	265
9	-	186	-	200	-	208	-	213	-	222	-	231	-	235
10	151	165	-	180	-	187	175	192	-	200	-	208	-	212
11	117	152	-	163	-	170	135	174	-	181	-	189	-	192
12	91	136	146	150	-	156	107	160	-	166	-	173	-	176
13	73	116	117	138	-	144	85	147	138	153	-	160	-	163
14	56	100	95	128	-	134	64	129	113	142	-	148	-	151
15	42	87	78	112	115	125	57	112	93	133	135	138	-	141
16	40	76	65	98	96	116	47	95	78	125	113	130	-	132
17			55	87	80	103	40	80	65	112	95	122	-	124
18			47	77	68	82			56	100	81	115	108	117
19			40	66	58	72			45	86	70	106	93	111
20					50	74			41	81	60	96	80	106
21					44	67					52	87	70	99
22											46	79	61	90
23														
24														
25														

- Total Load values are limited by shear, moment, or deflection equal to L/240.
- Live Load values are limited by deflection equal to L/480. For deflection limits of L/360 and L/960, multiply the Live Load values by 1.33 and 0.50 respectively.
- Both the Total Load and Live Load columns must be checked. Where a Live Load value is not shown, the Total Load value will control.
- Table values apply to either simple or multiple span joists. Span is measured center to center of the minimum required bearing length. Analyze multiple span joists with the BC Calc® software if the length of any span is less than half the length of an adjacent span.
- Table values do not consider composite action from gluing and nailing floor sheathing (composite action is considered in floor span tables on page 4).
- Total Load values assume minimum bearing lengths without web stiffeners for joist depths of 16 inches and less. 18 and 20 inch joists require web stiffeners.
- For assistance with floor design, consult the section *About Floor Performance* on page 4.
- This table was designed to apply to a broad range of applications. It may be possible to exceed the limitations of this table by analyzing a specific application with the BC Calc® software.

Allowable Uniform Floor Load (in pounds per lineal foot [PLF])

100% Load Duration

Span Length	BCI® 6500 1.8 Series 2 ⁹ / ₁₆ " Flange Width								BCI® 30 2.0 Series 2 ⁵ / ₁₆ " Flange Width					
	9 ¹ / ₂ " BCI® 6500 1.8		11 ⁷ / ₈ " BCI® 6500 1.8		14" BCI® 6500 1.8		16" BCI® 6500 1.8		11 ⁷ / ₈ " BCI® 60 2.0		14" BCI® 60 2.0		16" BCI® 60 2.0	
	Live Load	Total Load	Live Load	Total Load	Live Load	Total Load	Live Load	Total Load	Live Load	Total Load	Live Load	Total Load	Live Load	Total Load
6	-	320	-	333	-	346	-	353	-	366	-	366	-	366
7	-	274	-	285	-	297	-	302	-	314	-	314	-	314
8	-	240	-	250	-	260	-	265	-	275	-	275	-	275
9	-	213	-	222	-	231	-	235	-	244	-	244	-	244
10	190	192	-	200	-	208	-	212	-	220	-	220	-	220
11	147	174	-	181	-	189	-	192	-	200	-	200	-	200
12	116	160	-	166	-	173	-	176	-	183	-	183	-	183
13	93	147	152	153	-	160	-	163	-	169	-	169	-	169
14	76	137	124	142	-	148	-	151	149	157	-	157	-	157
15	62	124	103	133	-	138	-	141	123	146	-	146	-	146
16	52	104	85	125	123	130	-	132	103	137	-	137	-	137
17	44	88	72	117	104	122	-	124	87	129	125	124	-	129
18			61	110	88	115	117	117	74	122	106	122	-	122
19			52	99	76	109	101	111	63	115	92	115	-	115
20			45	89	65	104	87	106	55	110	77	110	105	110
21					57	96	76	100	48	96	69	104	92	104
22					50	88	66	96	42	84	60	100	81	100
23					44	80	58	92			53	95	71	95
24							52	84			47	91	63	91
25							46	77			42	84	56	88
26							41	72					50	84
27													45	81
28													40	78
29														
30														



Allowable Uniform Floor Load

(in pounds per lineal foot [PLF])

100% Load Duration

Span Length	BCI® 90 2.0 Series 3½" Flange Width									
	11⅞" BCI® 90 2.0		14" BCI® 90 2.0		16" BCI® 90 2.0		18" BCI® 90 2.0		20" BCI® 90 2.0	
	Live Load	Total Load	Live Load	Total Load	Live Load	Total Load	Live Load	Total Load	Live Load	Total Load
6	-	450	-	453	-	456	-	553	-	573
7	-	385	-	388	-	391	-	474	-	491
8	-	337	-	340	-	342	-	415	-	430
9	-	300	-	302	-	304	-	368	-	382
10	-	270	-	272	-	274	-	332	-	344
11	-	245	-	247	-	249	-	301	-	312
12	-	225	-	226	-	228	-	276	-	286
13	-	207	-	209	-	210	-	255	-	264
14	-	192	-	194	-	195	-	237	-	245
15	174	180	-	181	-	182	-	221	-	229
16	146	168	-	170	-	171	-	207	-	215
17	124	158	-	160	-	161	-	195	-	202
18	106	150	150	151	-	152	-	184	-	191
19	91	142	129	143	-	144	-	174	-	181
20	79	135	112	136	-	137	-	166	-	172
21	69	128	98	129	-	130	-	158	-	163
22	61	122	86	123	115	124	146	150	-	156
23	53	107	76	118	101	119	129	144	-	149
24	47	95	68	113	90	114	115	138	-	143
25	42	85	60	108	80	109	103	132	128	137
26			54	104	72	105	92	127	115	132
27			48	97	65	101	83	122	104	127
28			44	88	58	97	75	118	94	122
29					53	94	68	114	85	118
30					48	91	62	110	77	114

- Total Load values are limited by shear, moment, or deflection equal to $L/240$.
- Live Load values are limited by deflection equal to $L/480$. For deflection limits of $L/360$ and $L/960$ multiply the Live Load values by 1.33 and 0.50 respectively.
- Both the Total Load and Live Load columns must be checked. Where a Live Load value is not shown, the Total Load value will control.
- Table values apply to either simple or multiple span joists. Span is measured center to center of the minimum required bearing length. Analyze multiple span joists with the BC Calc® software if the length of any span is less than half the length of an adjacent span.
- Table values do not consider composite action from gluing and nailing floor sheathing (composite action is considered in floor span tables on page 4).
- Total Load values assume minimum bearing lengths without web stiffeners for joist depths of 16 inches and less.
- For assistance with floor design, consult the section About Floor Performance on page 4.
- This table was designed to apply to a broad range of applications. It may be possible to exceed the limitations of this table by analyzing a specific application with the BC Calc® software.

BCI® Rafters

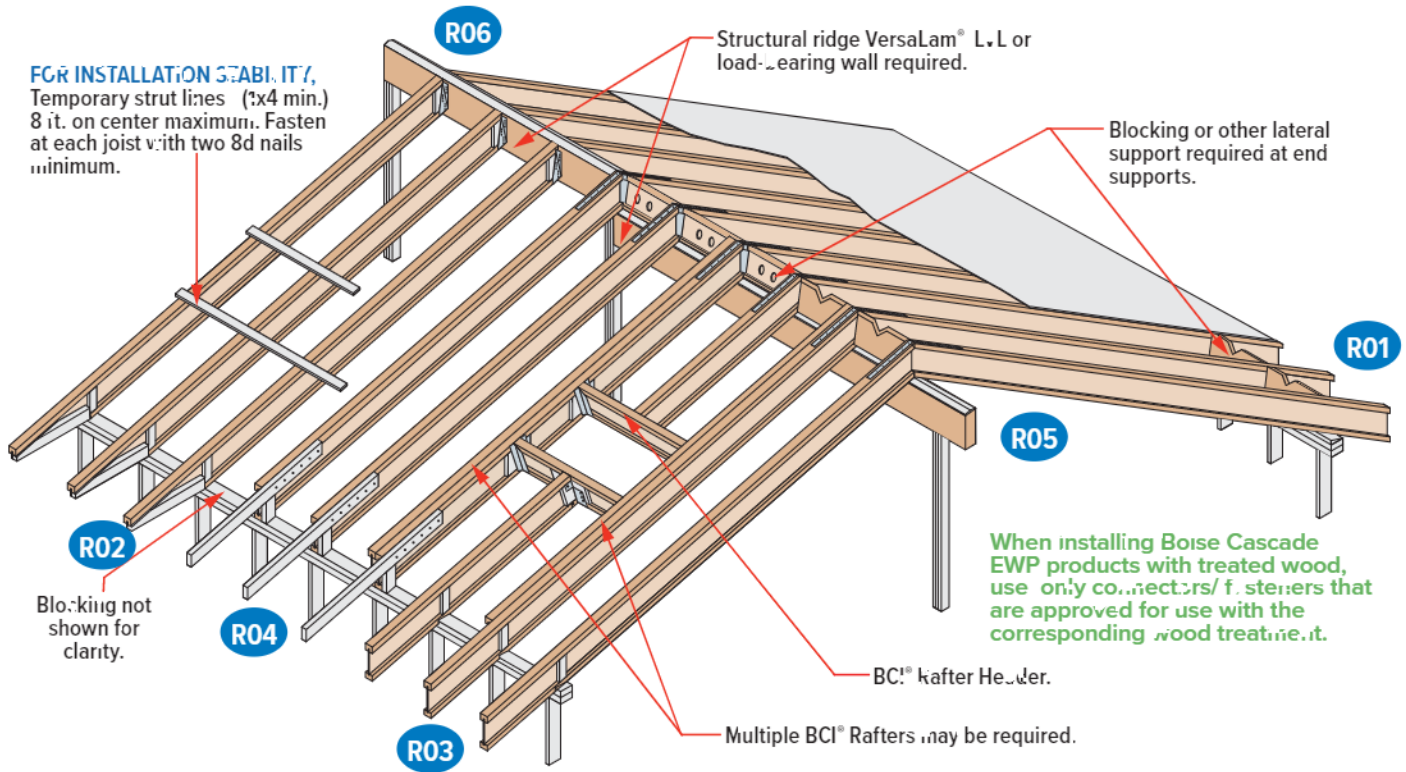

SAFETY WARNING

DO NOT ALLOW WORKERS ON BCI® JOISTS UNTIL ALL HANGERS, BCI® RIM JOISTS, RIM BOARDS, BCI® BLOCKING PANELS, X-BRACING AND TEMPORARY 1x4 STRUT LINES ARE INSTALLED AS SPECIFIED BELOW.

SERIOUS ACCIDENTS CAN RESULT FROM INSUFFICIENT ATTENTION TO PROPER BRACING DURING CONSTRUCTION. ACCIDENTS CAN BE AVOIDED UNDER NORMAL CONDITIONS BY FOLLOWING THESE GUIDELINES:

- Build a braced end wall at the end of the bay, or permanently install the first eight feet of BCI® Joists and the first course of sheathing. As an alternate, temporary sheathing may be nailed to the first four feet of BCI® Joists at the end of the bay.
- All hangers, BCI® rim joists, rim boards, BCI® blocking panels, and x-bracing must be completely installed and properly nailed as each BCI® Joist is set.
- Install temporary 1x4 strut lines at no more than eight feet on center as additional BCI® joists are set. Nail the strut lines to the sheathed area, or braced end wall, and to each BCI® Joist with two 8d nails.
- The ends of cantilevers must be temporarily secured by strut lines on both the top and bottom flanges.
- Straighten the BCI® Joists to within 1/2 inch of true alignment before attaching strut lines and sheathing.
- remove the temporary strut lines only as required to install the permanent sheathing.
- Failure to install temporary bracing may result in sideways buckling or roll-over under light construction loads.

BCI® Ceiling Joist with Bevel End Cut (For Limited-Access Attics Only)

BCI® Joist shall not be used as collar/tensile tie. Roof rafter shall be supported by ridge beam or other upper bearing support.

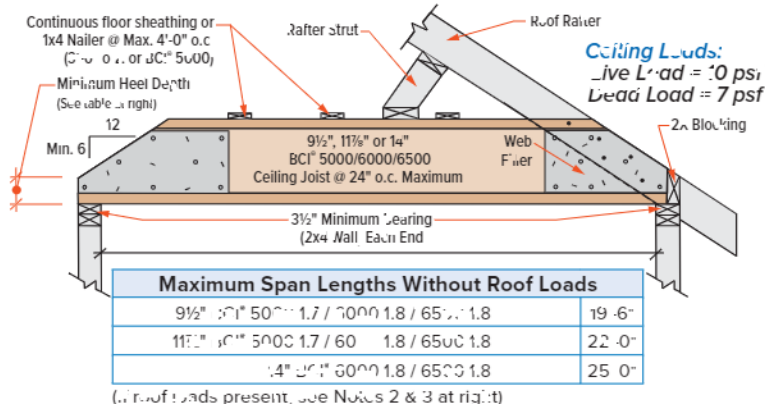

Minimum Heel Depths	Joist Depth	End Wall	
		2 x 4	2 x 6
	9 1/2"	2 1/2"	1 1/2"
	11 1/2"	3 1/2"	2 1/2"
	14"	4 1/2"	3 1/2"

Notes:

- 1) Detail is to be used only for ceiling joist with no access to attic space.
- 2) Ceiling joist must be designed to carry all roof load transferred through rafter struts as shown.
- 3) BCI® ceiling joist end reaction may not exceed 550 pounds.
- 4) Minimum roof slope is 6/12.
- 5) Nail roof rafter to BCI® top flange with 1-10d (3" long) box or larger nail.
- 6) 2x4 nailers must be continuous and nailed to a braced end wall.
- 7) Install a web filler on each side of BCI® Joist at beveled ends. Nail roof rafter to BCI® joist per building code requirements for ceiling joist to roof rafter connection.

Additional roof framing details available with BC Framers® software

R01

2x beveled plate for slope greater than 1/4/12.

Simpson VPA or USP TMP connectors or equal can be used in lieu of beveled plate for slopes from 3/12 to 12/12.

R02

Rimboard / Versa-Lam LVL blocking. Ventilation "V" cut. 1/2 of length, 1/2 of depth.

2x4 blocking for soffit support.

2'-6" max.

Flange of BCI® Joists may be birdsmouth cut only at the low end of the joist. Birds-mouth cut BCI® Joist flange must bear fully on plate. Web stiffener required each side. Bottom flange shall be fully supported.

R03

Rimboard / Versa-Lam LVL blocking. Ventilation "V" cut. 1/2 of length, 1/2 of depth.

Right fit for lateral stability.

Flange of BCI® Joists may be birdsmouth cut only at the low end of the joist. Birds-mouth cut BCI® Joist flange must bear fully on plate. Web stiffener required each side.

2'-6" max.

R04

10d nails at 6" o.c.

2x4 one side for 135 PLF max. 2x6 one side for 240 PLF max.

Backer block. Thickness per corresponding BCI® series.

2x block.

BCI® blocking. Holes cut for ventilation.

4'-0" horiz.

2'-6" horiz.

R05

Simpson or USP LSTA24 strap, nailing per governing building code.

Versa-Lam® LVL support beam.

BCI® blocking. Holes cut for ventilation.

Double-beveled wood plate.

Blocking on both sides of ridge may be required for shear transfer per design professional of record.

R06

Simpson or USP LSTA24 strap, wire strap if exceeds 1/12 slope (straps may be required for lower slopes in high-wind areas). Nailing per governing building code.

Versa-Lam® LVL support beam.

Beveled web stiffener on each side.

Simpson LSSUI or USP TMU hanger.

R07

Backer block (minimum 12" wide). Nail with 10-10d nails.

Joist Hanger.

Filler block. Nail with 10-10d nails.

Backer block required where top flange joist hanger load exceeds 250 lbs. Install tight to top flange.

R11

Double joist may be required when L exceeds rafter spacing.

Blocking as required.

Nail outrigger through BCI® web.

2" x 2" outrigger notched around BCI® top flange. Outrigger spacing no greater than 24" on-center.

End Wall.

L (2'-0" max.)

DN05

DO NOT bevel-cut joist beyond inside face of wall, except for specific conditions in details shown on pages 6 and 13 of the Specifier Guide.

LATERAL SUPPORT

- BCI® Joists must be laterally supported at end supports (including supports adjacent to overhangs) with hangers, rimboard or blocking (Versa-Lam® LVL, Boise Cascade® Rimboard or BCI® Joist). Metal cross bracing or other x-bracing provides adequate lateral support for BCI® Joists, consult governing building code for roof diaphragm connection provisions.

MINIMUM BEARING LENGTH -FOR BCI® JOISTS

- Minimum end bearing: 1.2" for all BCI® Joists. 3.2" is required at cantilever and intermediate supports.
- Longer bearing lengths allow higher reaction values. Refer to the building code evaluation report or the BC Calc® software.

NAILING REQUIREMENTS

- BCI® rim joist, rim board or closure panel to BCI® joist:
 - Rims or closure panel 1 3/4 inches thick and less: 2-8d nails, one each in the top and bottom flange.
 - BCI® 5000 rim joist: 2-10d box nails, one each in the top and bottom flange.
 - BCI® 6000/60 rim joist: 2-16d box nails, one each in the top and bottom flange.
 - BCI® 6500/90 rim joist: Toe-nail top flange to rim joist with 2-10d box nails, one each side of flange.
- BCI® rim joist, rim board or BCI® blocking panel to support:
 - Min. 8d nails @ 6" o.c. per IRC®.
 - Connection per design professional of record's specification for shear transfer.
- BCI® joist to support:
 - 2-8d nails, one on each side of the web, placed 1 1/2 inches minimum from the end of the BCI® Joist to limit splitting.

- Sheathing to BCI® joist:
 - Prescriptive residential floor sheathing nailing requires 8d common nails @ 6" o.c. on edges and @ 12" o.c. in the field (IRC® table R602.3(1)).
 - See closest allowable nail spacing limits on page 24 for floor diaphragm nailing specified at closer spacing than IRC®.
 - Maximum nail spacing for minimum lateral stability: 18" for BCI® 5000, 24" for larger BCI® joist series.
 - 1" gauge staples may be substituted for 8d nails if the staples penetrate at least 1 inch into the joist.
 - Wood screws may be acceptable, contact local building official and/or Boise Cascade EWP Engineering for further information.

BACKER AND FILLER BLOCK DIMENSIONS

Series	Backer Block Thickness	Filler Block Thickness
5000 1.7	3/4" or 7/8" wood panels	Two 3/4" wood panels or 2 x ...
6000 1.8	1 1/2" or two 1/2" wood panels	2 x ... + 7/8" or 1/2" wood panel
6500 1.8	1 1/2" or two 5/8" wood panels	2 x ... + 5/8" or 3/4" wood panel
60 2.0	1 1/2" or two 1/2" wood panels	2 x ... + 7/8" or 1/2" wood panel
90 2.0	2 x ... lumber	Double 2 x ... lumber

- Cut backer and filler blocks to a maximum depth equal to the web depth minus 1/4" to avoid a forced fit.

WEB STIFFENER REQUIREMENTS

- See *Web Stiffener Requirements* on page 9.

PROTECT BCI® JOISTS FROM THE WEATHER

- BCI® Joists are intended only for applications that provide permanent protection from the weather. Bundles of BCI® Joists should be covered and stored off of the ground on stickers.

MAXIMUM SLOPE

- Unless otherwise noted, all roof details are valid for slopes of 12 in 12 or less.

VENTILATION

- The 1/2 inch, pre-stamped knock-out holes spaced at 12 inches on center along the BCI® Joist may all be knocked out and used for cross ventilation. Deeper joists that what is structurally needed may be advantageous in ventilation design. Consult local building official and/or ventilation specialist for specific ventilation requirements.

BIRDSMOUTH CUTS

- BCI® Joists may be birdsmouth cut only at the low end support. BCI® Joists with birdsmouth cuts may cantilever up to 2'-6" past the low end support. The bottom flange must sit fully on the support and may not overhang the inside face of the support. High end supports and intermediate supports may not be birdsmouth cut.

Maximum clear span in feet and inches, based on horizontal spans.

115% and 125% Load Duration

			BCI® 6500 1.8 Series 2 ⁹ / ₁₆ " Flange Width													
			9½" BCI® 6500 1.8			11⅞" BCI® 6500 1.8			14" BCI® 6500 1.8			16" BCI® 6500 1.8				
		Live Load [psf]	Dead Load [psf]	4/12 or Less	4/12 to 8/12	8/12 to 12/12	4/12 or Less	4/12 to 8/12	8/12 to 12/12	4/12 or Less	4/12 to 8/12	8/12 to 12/12	4/12 or Less	4/12 to 8/12	8/12 to 12/12	
12" o.c.	Non-Snow 125%	20	10	26'-5"	24'-11"	23'-1"	31'-5"	29'-7"	27'-5"	35'-9"	33'-8"	31'-3"	39'-6"	37'-3"	34'-7"	
		20	15	25'-0"	23'-6"	21'-8"	29'-9"	27'-11"	25'-9"	33'-10"	31'-9"	29'-4"	37'-5"	35'-2"	32'-5"	
		20	20	23'-10"	22'-4"	20'-6"	28'-4"	26'-7"	24'-5"	32'-3"	30'-3"	27'-9"	35'-8"	33'-5"	30'-9"	
	Snow 115%	25	10	25'-1"	23'-8"	22'-1"	29'-10"	28'-2"	26'-2"	33'-11"	32'-1"	29'-10"	37'-6"	35'-5"	33'-0"	
		25	15	23'-11"	22'-6"	20'-10"	28'-5"	26'-9"	24'-9"	32'-4"	30'-5"	28'-2"	35'-9"	33'-8"	31'-2"	
		30	10	23'-11"	22'-8"	21'-2"	28'-6"	27'-0"	25'-2"	32'-5"	30'-8"	28'-8"	35'-10"	33'-11"	31'-8"	
		30	15	23'-0"	21'-8"	20'-1"	27'-4"	25'-9"	23'-11"	31'-1"	29'-4"	27'-3"	34'-5"	32'-5"	30'-1"	
		40	10	21'-10"	20'-11"	19'-9"	25'-11"	24'-10"	23'-6"	29'-6"	28'-4"	26'-9"	32'-8"	31'-4"	29'-7"	
		40	15	21'-5"	20'-4"	18'-11"	25'-6"	24'-2"	22'-6"	29'-1"	27'-6"	25'-7"	31'-5"	30'-5"	28'-4"	
		50	10	20'-2"	19'-4"	18'-4"	24'-0"	23'-0"	21'-10"	27'-4"	26'-3"	24'-11"	30'-2"	29'-0"	27'-6"	
	50	15	20'-2"	19'-3"	18'-0"	24'-0"	22'-10"	21'-4"	27'-0"	26'-0"	24'-4"	28'-11"	28'-5"	26'-11"		
	16" o.c.	Non-Snow 125%	20	10	23'-11"	22'-7"	20'-11"	28'-5"	26'-10"	24'-11"	32'-5"	30'-6"	28'-4"	35'-10"	33'-9"	31'-4"
			20	15	22'-8"	21'-3"	19'-8"	26'-11"	25'-4"	23'-4"	30'-8"	28'-10"	26'-7"	33'-11"	31'-10"	29'-5"
			20	20	21'-7"	20'-3"	18'-7"	25'-8"	24'-1"	22'-1"	29'-3"	27'-5"	25'-2"	32'-4"	30'-3"	27'-10"
Snow 115%		25	10	22'-8"	21'-6"	20'-0"	27'-0"	25'-6"	23'-9"	30'-9"	29'-1"	27'-1"	34'-0"	32'-2"	29'-11"	
		25	15	21'-8"	20'-5"	18'-11"	25'-9"	24'-3"	22'-5"	29'-4"	27'-7"	25'-7"	31'-10"	30'-6"	28'-3"	
		30	10	21'-8"	20'-7"	19'-2"	25'-10"	24'-5"	22'-10"	29'-5"	27'-10"	26'-0"	31'-11"	30'-9"	28'-9"	
		30	15	20'-10"	19'-8"	18'-3"	24'-9"	23'-4"	21'-8"	28'-1"	26'-7"	24'-8"	30'-0"	29'-4"	27'-4"	
		40	10	19'-9"	18'-11"	17'-10"	23'-6"	22'-6"	21'-3"	26'-9"	25'-8"	24'-3"	28'-7"	28'-2"	26'-9"	
		40	15	19'-5"	18'-5"	17'-2"	23'-1"	21'-11"	20'-5"	25'-5"	24'-11"	23'-3"	27'-2"	26'-8"	25'-8"	
		50	10	18'-3"	17'-6"	16'-8"	21'-9"	20'-10"	19'-10"	24'-5"	23'-9"	22'-7"	26'-1"	25'-9"	24'-11"	
50		15	18'-3"	17'-5"	16'-3"	21'-5"	20'-9"	19'-4"	23'-5"	23'-0"	22'-0"	25'-0"	24'-7"	24'-0"		
19.2" o.c.		Non-Snow 125%	20	10	22'-6"	21'-2"	19'-8"	26'-9"	25'-2"	23'-5"	30'-5"	28'-8"	26'-8"	33'-8"	31'-9"	29'-5"
			20	15	21'-3"	20'-0"	18'-5"	25'-4"	23'-9"	21'-11"	28'-10"	27'-1"	25'-0"	31'-10"	29'-11"	27'-7"
			20	20	20'-3"	19'-0"	17'-6"	24'-2"	22'-7"	20'-9"	27'-6"	25'-9"	23'-8"	30'-2"	28'-5"	26'-2"
	Snow 115%	25	10	21'-4"	20'-2"	18'-9"	25'-4"	24'-0"	22'-4"	28'-11"	27'-4"	25'-5"	31'-1"	30'-2"	28'-1"	
		25	15	20'-4"	19'-2"	17'-9"	24'-2"	22'-9"	21'-1"	27'-2"	25'-11"	24'-0"	29'-0"	28'-3"	26'-7"	
		30	10	20'-4"	19'-4"	18'-0"	24'-3"	23'-0"	21'-5"	27'-3"	26'-2"	24'-5"	29'-1"	28'-7"	27'-0"	
		30	15	19'-6"	18'-5"	17'-1"	23'-3"	21'-11"	20'-4"	25'-7"	25'-0"	23'-2"	27'-5"	26'-9"	25'-8"	
		40	10	18'-6"	17'-9"	16'-9"	22'-1"	21'-2"	20'-0"	24'-4"	24'-0"	22'-9"	26'-1"	25'-8"	25'-2"	
		40	15	18'-3"	17'-3"	16'-1"	21'-3"	20'-7"	19'-2"	23'-2"	22'-9"	21'-10"	24'-9"	24'-4"	23'-8"	
		50	10	17'-1"	16'-5"	15'-7"	20'-5"	19'-7"	18'-7"	22'-3"	22'-0"	21'-2"	23'-9"	23'-6"	23'-1"	
	50	15	17'-1"	16'-4"	15'-3"	19'-7"	19'-3"	18'-2"	21'-4"	21'-0"	20'-6"	22'-10"	22'-2"	21'-2"		
	24" o.c.	Non-Snow 125%	20	10	20'-10"	19'-8"	18'-3"	24'-9"	23'-4"	21'-8"	28'-2"	26'-7"	24'-8"	31'-2"	29'-5"	27'-4"
			20	15	19'-8"	18'-6"	17'-1"	23'-5"	22'-0"	20'-4"	26'-8"	25'-1"	23'-2"	28'-11"	27'-9"	25'-7"
			20	20	18'-9"	17'-7"	16'-2"	22'-4"	20'-11"	19'-3"	25'-3"	23'-10"	21'-11"	26'-11"	26'-0"	24'-3"
Snow 115%		25	10	19'-9"	18'-8"	17'-5"	23'-6"	22'-3"	20'-8"	26'-0"	25'-4"	23'-7"	27'-10"	27'-3"	26'-1"	
		25	15	18'-10"	17'-9"	16'-5"	22'-3"	21'-1"	19'-6"	24'-3"	23'-7"	22'-3"	25'-11"	25'-3"	24'-4"	
		30	10	18'-10"	17'-10"	16'-8"	22'-4"	21'-3"	19'-10"	24'-4"	23'-11"	22'-7"	26'-0"	25'-7"	24'-11"	
		30	15	18'-1"	17'-1"	15'-10"	21'-0"	20'-4"	18'-10"	22'-10"	22'-4"	21'-6"	24'-5"	23'-11"	23'-1"	
		40	10	17'-1"	16'-5"	15'-6"	20'-0"	19'-7"	18'-6"	21'-9"	21'-5"	21'-0"	23'-3"	22'-11"	22'-3"	
		40	15	16'-9"	16'-0"	14'-11"	19'-0"	18'-7"	17'-9"	20'-8"	20'-4"	19'-3"	21'-7"	20'-9"	19'-8"	
		50	10	15'-10"	15'-2"	14'-5"	18'-3"	18'-0"	17'-3"	19'-6"	19'-0"	18'-5"	19'-10"	19'-5"	18'-9"	
50		15	15'-5"	15'-1"	14'-1"	17'-3"	16'-8"	15'-11"	17'-11"	17'-4"	16'-6"	18'-3"	17'-8"	16'-10"		



Maximum clear span in feet and inches, based on horizontal spans.

			BCI® 60 2.0 Series 2 ⁹ / ₁₆ " Flange Width										
			11 ⁷ / ₈ " BCI® 60 2.0			14" BCI® 60 2.0			16" BCI® 60 2.0				
	Live Load [psf]	Dead Load [psf]	4/12 or Less	4/12 to 8/12	8/12 to 12/12	4/12 or Less	4/12 to 8/12	8/12 to 12/12	4/12 or Less	4/12 to 8/12	8/12 to 12/12		
12" o.c.	Non-Snow 125%	20	10	33'-7"	31'-8"	29'-5"	38'-4"	36'-1"	33'-6"	42'-5"	40'-0"	37'-1"	
		20	15	31'-10"	29'-11"	27'-7"	36'-3"	34'-1"	31'-5"	40'-2"	37'-8"	34'-10"	
		20	20	30'-4"	28'-5"	26'-2"	34'-7"	32'-5"	29'-9"	38'-4"	35'-10"	33'-0"	
	Snow 115%	25	10	31'-11"	30'-2"	28'-1"	36'-4"	34'-4"	32'-0"	40'-3"	38'-1"	35'-5"	
		25	15	30'-5"	28'-8"	26'-6"	34'-8"	32'-8"	30'-3"	38'-5"	36'-2"	33'-6"	
		30	10	30'-6"	28'-11"	26'-11"	34'-9"	32'-11"	30'-8"	38'-6"	36'-5"	34'-0"	
		30	15	29'-3"	27'-7"	25'-7"	33'-4"	31'-5"	29'-2"	36'-11"	34'-10"	32'-4"	
		40	10	27'-9"	26'-7"	25'-2"	31'-8"	30'-4"	28'-8"	35'-0"	33'-7"	31'-9"	
		40	15	27'-4"	25'-10"	24'-1"	31'-2"	29'-6"	27'-6"	34'-6"	32'-8"	30'-5"	
		50	10	25'-9"	24'-8"	23'-5"	29'-4"	28'-1"	26'-8"	32'-5"	31'-1"	29'-6"	
		50	15	25'-9"	24'-6"	22'-11"	29'-4"	27'-11"	26'-1"	32'-5"	30'-11"	28'-11"	
	16" o.c.	Non-Snow 125%	20	10	30'-5"	28'-9"	26'-8"	34'-9"	32'-9"	30'-5"	38'-5"	36'-3"	33'-8"
			20	15	28'-10"	27'-1"	25'-0"	32'-10"	30'-10"	28'-6"	36'-5"	34'-2"	31'-7"
			20	20	27'-6"	25'-9"	23'-8"	31'-4"	29'-4"	27'-0"	34'-9"	32'-6"	29'-11"
Snow 115%		25	10	28'-11"	27'-4"	25'-5"	32'-11"	31'-2"	29'-0"	36'-6"	34'-6"	32'-1"	
		25	15	27'-7"	26'-0"	24'-1"	31'-5"	29'-7"	27'-5"	34'-10"	32'-9"	30'-4"	
		30	10	27'-8"	26'-2"	24'-5"	31'-6"	29'-10"	27'-10"	34'-11"	33'-0"	30'-10"	
		30	15	26'-6"	25'-0"	23'-3"	30'-2"	28'-6"	26'-6"	33'-5"	31'-7"	29'-4"	
		40	10	25'-2"	24'-1"	22'-9"	28'-8"	27'-6"	26'-0"	31'-9"	30'-5"	28'-9"	
		40	15	24'-9"	23'-5"	21'-10"	28'-3"	26'-8"	24'-11"	31'-3"	29'-7"	27'-7"	
		50	10	23'-3"	22'-4"	21'-2"	26'-6"	25'-5"	24'-2"	29'-5"	28'-2"	26'-9"	
		50	15	23'-3"	22'-2"	20'-9"	26'-6"	25'-3"	23'-8"	28'-7"	27'-8"	26'-2"	
19.2" o.c.		Non-Snow 125%	20	10	28'-7"	27'-0"	25'-1"	32'-7"	30'-9"	28'-7"	36'-1"	34'-1"	31'-7"
			20	15	27'-1"	25'-5"	23'-6"	30'-10"	29'-0"	26'-9"	34'-2"	32'-1"	29'-8"
			20	20	25'-10"	24'-2"	22'-3"	29'-5"	27'-7"	25'-4"	32'-7"	30'-6"	28'-1"
	Snow 115%	25	10	27'-2"	25'-8"	23'-11"	30'-11"	29'-3"	27'-3"	34'-3"	32'-5"	30'-2"	
		25	15	25'-11"	24'-5"	22'-7"	29'-6"	27'-10"	25'-9"	32'-8"	30'-9"	28'-6"	
		30	10	25'-11"	24'-7"	22'-11"	29'-7"	28'-0"	26'-2"	32'-9"	31'-0"	29'-0"	
		30	15	24'-11"	23'-6"	21'-10"	28'-4"	26'-9"	24'-10"	31'-5"	29'-8"	27'-6"	
		40	10	23'-7"	22'-8"	21'-5"	26'-11"	25'-10"	24'-5"	29'-10"	28'-7"	27'-0"	
		40	15	23'-3"	22'-0"	20'-6"	26'-6"	25'-1"	23'-5"	28'-1"	27'-0"	25'-7"	
		50	10	21'-10"	21'-0"	19'-11"	24'-11"	23'-11"	22'-8"	25'-10"	25'-3"	24'-5"	
		50	15	21'-10"	20'-10"	19'-6"	23'-9"	23'-0"	21'-11"	23'-9"	23'-0"	21'-11"	
	24" o.c.	Non-Snow 125%	20	10	26'-6"	25'-0"	23'-3"	30'-2"	28'-6"	26'-6"	33'-5"	31'-7"	29'-4"
			20	15	25'-1"	23'-7"	21'-9"	28'-7"	26'-10"	24'-10"	31'-8"	29'-9"	27'-6"
			20	20	23'-11"	22'-5"	20'-7"	27'-3"	25'-6"	23'-6"	30'-2"	28'-3"	26'-0"
Snow 115%		25	10	25'-2"	23'-9"	22'-2"	28'-8"	27'-1"	25'-3"	31'-9"	30'-0"	28'-0"	
		25	15	24'-0"	22'-7"	20'-11"	27'-4"	25'-9"	23'-10"	30'-3"	28'-6"	26'-5"	
		30	10	24'-0"	22'-9"	21'-3"	27'-5"	25'-11"	24'-3"	30'-4"	28'-9"	26'-10"	
		30	15	23'-0"	21'-9"	20'-2"	26'-3"	24'-9"	23'-0"	27'-4"	26'-1"	24'-5"	
		40	10	21'-10"	21'-0"	19'-10"	24'-9"	23'-11"	22'-7"	24'-9"	24'-1"	23'-1"	
		40	15	21'-6"	20'-4"	19'-0"	22'-5"	21'-6"	20'-5"	22'-5"	21'-6"	20'-5"	
		50	10	20'-2"	19'-5"	18'-5"	20'-8"	20'-2"	19'-6"	20'-8"	20'-2"	19'-6"	
		50	15	19'-0"	18'-4"	17'-6"	19'-0"	18'-4"	17'-6"	19'-0"	18'-4"	17'-6"	

- Table values are limited by shear, moment, total load deflection equal to L/180 and live load deflection equal to L/240. Check the local building code for other deflection limits that may apply.
- Table values represent the most restrictive of simple or multiple span applications. Analyze multiple span joists with the BC Calc® software if the length of any span is less than half the length of an adjacent span.
- Table values assume minimum bearing lengths without web stiffeners for joist depths of 16 inches and less.

This table was designed to apply to a broad range of applications. It may be possible to exceed the limitations of this table by analyzing a specific application with the BC Calc® software.

- Slope roof joists at least ¼" over 12" to minimize ponding.
- Allowable spans and loads shall be adjusted and checked for wind load as required by local building code.

Roof Span Tables

Maximum clear span in feet and inches, based on horizontal spans.

115% and 125% Load Duration

			BCI® 90 2.0 Series 3½" Flange Width															
			11½" BCI® 90 2.0			14" BCI® 90 2.0			16" BCI® 90 2.0			18" BCI® 90 2.0			20" BCI® 90 2.0			
			4/12 or Less	4/12 to 8/12	8/12 to 12/12	4/12 or Less	4/12 to 8/12	8/12 to 12/12	4/12 or Less	4/12 to 8/12	8/12 to 12/12	4/12 or Less	4/12 to 8/12	8/12 to 12/12	4/12 or Less	4/12 to 8/12	8/12 to 12/12	
o.c.	Live Load [psf]	Dead Load [psf]	115% and 125% Load Duration															
			12"	Non-Snow 125%	20	10	38'-5"	36'-3"	33'-8"	43'-7"	41'-2"	38'-2"	48'-4"	45'-7"	42'-3"	50'-0"	49'-9"	46'-2"
20	15	36'-5"			34'-2"	31'-7"	41'-4"	38'-10"	35'-10"	45'-9"	43'-0"	39'-8"	50'-0"	45'-1"	43'-4"	50'-0"	50'-0"	46'-11"
20	20	34'-9"			32'-6"	29'-11"	39'-5"	36'-1"	33'-11"	43'-8"	40'-10"	37'-7"	47'-8"	44'-8"	41'-1"	50'-0"	48'-4"	44'-5"
Snow 115%	25	10		37'-5"	34'-6"	32'-1"	41'-8"	39'-2"	36'-5"	46'-10"	43'-4"	40'-4"	50'-6"	47'-5"	44'-1"	50'-9"	50'-0"	47'-9"
	25	15		34'-10"	32'-9"	30'-4"	39'-6"	37'-2"	34'-5"	43'-9"	41'-2"	38'-2"	47'-10"	45'-3"	41'-8"	50'-0"	48'-8"	45'-1"
	30	10		34'-11"	33'-1"	30'-10"	39'-7"	37'-6"	35'-0"	43'-10"	41'-6"	38'-9"	47'-11"	45'-5"	42'-4"	50'-0"	43'-1"	45'-10"
	30	15		33'-5"	31'-7"	29'-4"	38'-0"	35'-10"	33'-3"	47'-1"	39'-8"	37'-10"	45'-11"	43'-1"	40'-3"	49'-3"	46'-1"	43'-7"
	40	10		31'-9"	30'-5"	28'-9"	37'-0"	34'-7"	32'-8"	39'-11"	38'-3"	36'-2"	43'-7"	41'-10"	39'-6"	47'-2"	45'-3"	42'-9"
	40	15		31'-3"	29'-7"	27'-7"	35'-6"	33'-7"	31'-3"	39'-3"	37'-2"	34'-8"	42'-11"	40'-8"	37'-10"	47'-5"	44'-0"	41'-0"
	50	10		29'-5"	28'-2"	26'-9"	33'-4"	32'-0"	30'-3"	36'-11"	35'-5"	33'-8"	40'-5"	38'-3"	36'-9"	43'-8"	41'-11"	39'-10"
50	15	29'-5"		28'-0"	26'-2"	33'-4"	31'-9"	29'-8"	36'-11"	35'-3"	32'-11"	40'-5"	38'-6"	36'-0"	43'-8"	41'-8"	38'-1"	
16"	Non-Snow 125%	20		10	34'-10"	32'-10"	30'-6"	39'-6"	37'-1"	34'-7"	43'-9"	41'-4"	38'-4"	47'-10"	45'-2"	41'-1"	50'-0"	48'-10"
		20	15	33'-0"	31'-0"	28'-7"	37'-5"	35'-2"	32'-6"	41'-5"	38'-11"	36'-0"	45'-4"	42'-7"	37'-4"	49'-0"	46'-1"	42'-6"
		20	20	31'-6"	29'-6"	27'-11"	35'-8"	33'-5"	30'-5"	39'-7"	37'-0"	34'-11"	43'-3"	40'-6"	37'-3"	46'-9"	43'-10"	40'-3"
	Snow 115%	25	10	33'-1"	31'-3"	29'-1"	37'-6"	35'-6"	33'-1"	41'-7"	39'-4"	37'-7"	45'-5"	42'-1"	40'-0"	45'-2"	46'-6"	43'-3"
		25	15	31'-6"	29'-8"	27'-6"	35'-9"	33'-8"	31'-3"	39'-8"	37'-4"	34'-7"	43'-4"	40'-0"	37'-9"	46'-10"	44'-2"	40'-11"
		30	10	31'-7"	29'-1"	27'-11"	35'-10"	34'-0"	31'-9"	39'-9"	37'-8"	35'-2"	43'-5"	41'-2"	38'-5"	47'-0"	44'-6"	41'-6"
		30	15	30'-4"	28'-7"	26'-7"	34'-5"	32'-5"	30'-2"	38'-1"	35'-11"	33'-5"	41'-7"	39'-3"	36'-6"	45'-0"	42'-6"	39'-6"
		40	10	28'-9"	27'-7"	26'-1"	32'-7"	31'-4"	29'-7"	36'-2"	34'-8"	32'-9"	39'-6"	37'-11"	35'-10"	42'-9"	41'-0"	38'-9"
		40	15	28'-4"	26'-9"	25'-0"	32'-1"	30'-5"	28'-4"	35'-7"	33'-8"	31'-5"	38'-10"	36'-10"	34'-4"	41'-1"	35'-10"	37'-2"
		50	10	26'-7"	25'-6"	24'-3"	30'-2"	29'-0"	27'-5"	33'-5"	32'-1"	30'-1"	35'-7"	35'-1"	33'-4"	39'-7"	38'-0"	36'-1"
	50	15	26'-7"	25'-4"	23'-9"	30'-2"	28'-9"	26'-11"	33'-5"	31'-11"	29'-10"	36'-7"	34'-10"	32'-7"	39'-7"	37'-8"	35'-3"	
	19.2"	Non-Snow 125%	20	10	32'-9"	30'-11"	28'-8"	37'-2"	35'-0"	32'-6"	41'-2"	38'-10"	36'-0"	44'-11"	42'-5"	38'-4"	48'-8"	45'-11"
20			15	31'-0"	29'-1"	26'-11"	35'-2"	33'-0"	30'-6"	38'-11"	36'-7"	33'-5"	42'-7"	40'-0"	36'-1"	46'-0"	43'-3"	39'-1"
20			20	29'-6"	27'-8"	25'-5"	33'-6"	31'-5"	28'-1"	37'-2"	34'-9"	32'-0"	40'-7"	38'-0"	35'-0"	43'-11"	41'-2"	37'-10"
Snow 115%		25	10	31'-1"	29'-5"	27'-4"	35'-3"	33'-4"	31'-1"	39'-0"	36'-11"	34'-5"	42'-8"	40'-4"	37'-7"	41'-2"	43'-8"	40'-8"
		25	15	29'-7"	27'-11"	25'-10"	33'-7"	31'-8"	29'-4"	37'-3"	35'-11"	32'-6"	40'-8"	38'-4"	35'-6"	44'-0"	41'-6"	38'-5"
		30	10	29'-8"	28'-1"	26'-3"	33'-8"	31'-11"	29'-10"	37'-4"	35'-4"	33'-0"	40'-9"	38'-8"	36'-1"	44'-1"	41'-10"	39'-0"
		30	15	28'-3"	26'-10"	24'-11"	32'-3"	30'-6"	28'-4"	35'-9"	33'-0"	31'-4"	39'-1"	36'-11"	34'-3"	42'-3"	39'-11"	37'-1"
		40	10	27'-0"	25'-11"	24'-6"	30'-7"	29'-5"	27'-9"	33'-11"	32'-7"	30'-9"	37'-1"	35'-1"	33'-7"	40'-1"	38'-6"	36'-5"
		40	15	26'-7"	25'-2"	23'-5"	30'-1"	28'-7"	26'-7"	33'-5"	31'-7"	29'-0"	36'-6"	34'-7"	32'-3"	39'-5"	37'-5"	34'-11"
		50	10	24'-11"	24'-0"	22'-9"	28'-4"	27'-2"	25'-10"	31'-5"	30'-2"	28'-8"	34'-4"	32'-11"	31'-4"	37'-11"	35'-8"	33'-10"
50		15	24'-11"	23'-10"	22'-3"	28'-4"	27'-0"	25'-3"	29'-8"	28'-8"	27'-5"	34'-4"	32'-8"	30'-7"	37'-1"	35'-5"	33'-1"	
24"		Non-Snow 125%	20	10	30'-4"	28'-7"	26'-7"	34'-5"	32'-5"	30'-2"	38'-1"	35'-11"	33'-5"	41'-7"	39'-3"	36'-6"	45'-0"	42'-6"
	20		15	28'-8"	26'-11"	24'-11"	32'-6"	30'-7"	28'-3"	36'-11"	33'-11"	31'-4"	39'-5"	37'-0"	34'-2"	42'-8"	40'-1"	37'-0"
	20		20	27'-4"	25'-7"	23'-7"	31'-0"	29'-1"	26'-9"	34'-4"	31'-2"	29'-8"	37'-7"	35'-2"	32'-5"	40'-8"	38'-1"	35'-11"
	Snow 115%	25	10	28'-9"	27'-2"	25'-4"	32'-7"	30'-10"	28'-9"	36'-2"	34'-2"	31'-10"	39'-6"	37'-4"	34'-0"	42'-9"	40'-5"	37'-8"
		25	15	27'-5"	25'-10"	23'-11"	31'-1"	29'-4"	27'-2"	34'-5"	32'-6"	30'-1"	37'-8"	35'-6"	32'-1"	40'-9"	38'-5"	35'-7"
		30	10	27'-6"	26'-0"	24'-4"	31'-2"	29'-1"	27'-7"	34'-6"	32'-9"	30'-7"	37'-9"	35'-9"	33'-5"	40'-10"	38'-9"	36'-2"
		30	15	26'-4"	24'-10"	23'-1"	29'-10"	28'-2"	26'-3"	33'-11"	31'-3"	29'-1"	36'-2"	34'-2"	31'-9"	39'-2"	37'-0"	34'-4"
		40	10	24'-11"	24'-0"	22'-8"	28'-4"	27'-2"	25'-9"	30'-11"	30'-0"	28'-0"	34'-4"	32'-11"	31'-2"	37'-1"	35'-8"	33'-8"
		40	15	24'-7"	23'-3"	21'-9"	27'-3"	26'-5"	24'-8"	28'-0"	26'-11"	25'-6"	33'-3"	32'-0"	29'-10"	35'-2"	33'-10"	32'-1"
		50	10	23'-1"	22'-2"	21'-1"	25'-7"	24'-11"	23'-11"	25'-9"	23'-2"	24'-4"	31'-3"	30'-6"	29'-9"	32'-5"	31'-8"	30'-7"
	50	15	23'-1"	22'-0"	20'-7"	23'-7"	22'-9"	21'-8"	23'-8"	22'-11"	21'-10"	28'-9"	27'-10"	26'-7"	29'-10"	28'-10"	27'-6"	



Allowable Uniform Roof Load
(in pounds per lineal foot [PLF])

115% and 125% Load Duration

Use of these tables should be limited to roof slopes of 3½" per foot or less.
For steeper slopes, see pages 15-18.

Span Length	BCI® 5000 1.7 Series 2" Flange Width								
	9½" BCI® 5000 1.7			11⅞" BCI® 5000 1.7			14" BCI® 5000 1.7		
	Total Load		Deflect.	Total Load		Deflect.	Total Load		Deflect.
	Snow (115%)	Non-Snow (125%)	L/240	Snow (115%)	Non-Snow (125%)	L/240	Snow (115%)	Non-Snow (125%)	L/240
6	315	343	-	338	367	-	353	383	-
7	270	294	-	289	315	-	302	329	-
8	236	257	-	253	275	-	264	287	-
9	210	228	-	225	245	-	235	255	-
10	189	205	-	202	220	-	211	230	-
11	172	187	-	184	200	-	192	209	-
12	154	167	-	169	183	-	176	191	-
13	131	142	-	156	169	-	162	177	-
14	113	123	110	141	157	-	151	164	-
15	98	107	90	126	137	-	141	153	-
16	86	94	75	110	120	-	131	142	-
17	76	82	63	98	106	-	116	126	-
18	68	70	53	87	95	-	103	112	-
19	59	59	45	78	85	74	93	101	-
20	51	51	39	71	77	64	84	91	-
21				64	70	55	76	83	-
22				58	63	48	69	75	-
23				53	55	42	63	69	62
24							58	63	55
25							53	58	49
26									
27									
28									

- Total Load values are limited by shear, moment, or deflection equal to L/180.
- Deflection values (Deflect.) are limited by live load deflection equal to L/240. Check the local building code for other deflection limits that may apply.
- Both the Total Load and Deflection columns must be checked. Where a Deflection value is not shown, the Total Load value will control.
- Table values apply to either simple or multiple span joists. Span is measured center to center of the minimum required bearing length. Analyze multiple span joists with the BC Calc® software if the length of any span is less than half the length of an adjacent span.
- Slope roof joists at least ¼ inch over 12 inches to minimize ponding.
- Table values assume minimum bearing lengths without web stiffeners for joist depths of 16 inches and less. 18 and 20 inch joists require web stiffeners.
- This table was designed to apply to a broad range of applications. It may be possible to exceed the limitations of this table by analyzing a specific application with the BC Calc® software.
- Allowable spans and loads shall be adjusted and checked for wind load as required by local building code.

Allowable Uniform Roof Load (in pounds per lineal foot [PLF])

115% and 125% Load Duration

Use of these tables should be limited to roof slopes of 3½" per foot or less.
For steeper slopes, see pages 15-18.

Span Length	BCI® 6000 1.8 Series 2 ⁵ / ₁₆ " Flange Width											
	9½" BCI® 6000 1.8			11⅞" BCI® 6000 1.8			14" BCI® 6000 1.8			16" BCI® 6000 1.8		
	Total Load		Deflect.	Total Load		Deflect.	Total Load		Deflect.	Total Load		Deflect.
	Snow (115%)	Non-Snow (125%)	L/240	Snow (115%)	Non-Snow (125%)	L/240	Snow (115%)	Non-Snow (125%)	L/240	Snow (115%)	Non-Snow (125%)	L/240
6	360	392	-	375	408	-	390	424	-	398	432	-
7	309	336	-	322	350	-	334	364	-	341	371	-
8	270	294	-	281	306	-	293	318	-	298	324	-
9	240	261	-	250	272	-	260	283	-	265	288	-
10	216	235	-	225	245	-	234	254	-	238	259	-
11	196	213	-	204	222	-	213	231	-	217	236	-
12	180	196	-	187	204	-	195	212	-	199	216	-
13	166	180	159	173	188	-	180	196	-	183	199	-
14	145	158	129	161	175	-	167	182	-	170	185	-
15	126	137	106	150	163	-	156	169	-	159	173	-
16	111	115	88	140	153	-	146	159	-	149	162	-
17	97	97	74	126	137	122	137	149	-	140	152	-
18	82	82	63	112	122	103	130	141	-	132	144	-
19	70	70	53	101	110	89	120	130	-	125	136	-
20	60	60	46	91	99	76	108	117	-	119	129	-
21	52	52	40	83	87	66	98	107	97	112	122	-
22				75	76	58	89	97	85	102	111	-
23				67	67	51	82	89	75	93	101	-
24				59	59	45	75	81	66	86	93	-
25				52	52	40	69	75	58	79	86	78
26							64	68	52	73	79	70
27							59	61	47	67	73	63
28							55	55	42	63	68	56



Allowable Uniform Roof Load
(in pounds per lineal foot [PLF])

115% and 125% Load Duration

Use of these tables should be limited to roof slopes of 3½" per foot or less.
For steeper slopes, see pages 15-18.

Span Length	BCI® 6500 1.8 Series 2 ⁹ / ₁₆ " Flange Width											
	9½" BCI® 6500 1.8			11 ⁷ / ₈ " BCI® 6500 1.8			14" BCI® 6500 1.8			16" BCI® 6500 1.8		
	Total Load		Deflect.	Total Load		Deflect.	Total Load		Deflect.	Total Load		Deflect.
	Snow (115%)	Non-Snow (125%)	L/240	Snow (115%)	Non-Snow (125%)	L/240	Snow (115%)	Non-Snow (125%)	L/240	Snow (115%)	Non-Snow (125%)	L/240
6	360	392	-	375	408	-	390	424	-	398	432	-
7	309	336	-	322	350	-	334	364	-	341	371	-
8	270	294	-	281	306	-	293	318	-	298	324	-
9	240	261	-	250	272	-	260	283	-	265	288	-
10	216	235	-	225	245	-	234	254	-	238	259	-
11	196	213	-	204	222	-	213	231	-	217	236	-
12	180	196	-	187	204	-	195	212	-	199	216	-
13	166	180	-	173	188	-	180	196	-	183	199	-
14	154	168	141	161	175	-	167	182	-	170	185	-
15	140	152	116	150	163	-	156	169	-	159	173	-
16	123	126	97	140	153	-	146	159	-	149	162	-
17	106	106	81	132	144	-	137	149	-	140	152	-
18	90	90	69	125	135	114	130	141	-	132	144	-
19	77	77	59	112	122	97	123	134	-	125	136	-
20	66	66	51	101	110	84	117	127	-	119	129	-
21	57	57	44	91	95	73	108	118	106	113	123	-
22	50	50	38	83	83	64	99	107	92	108	118	-
23				73	73	56	90	98	81	103	112	-
24				64	64	49	83	90	72	95	103	-
25				57	57	44	76	83	64	87	95	85
26				51	51	39	71	74	57	81	88	76
27							65	67	51	75	81	68
28							60	60	46	69	76	61
29							54	54	41	65	70	55
30										60	66	50
31										57	60	45
32										53	54	41
33										50	50	38
34												
35												

- Total Load values are limited by shear, moment, or deflection equal to L/180.
- Deflection values (Deflect.) are limited by live load deflection equal to L/240. Check the local building code for other deflection limits that may apply.
- Both the Total Load and Deflection columns must be checked. Where a Deflection value is not shown, the Total Load value will control.
- Table values apply to either simple or multiple span joists. Span is measured center to center of the minimum required bearing length. Analyze multiple span joists with the BC Calc® software if the length of any span is less than half the length of an adjacent span.
- Slope roof joists at least ¼ inch over 12 inches to minimize ponding.
- Table values assume minimum bearing lengths without web stiffeners for joist depths of 16 inches and less. 18 and 20 inch joists require web stiffeners.
- This table was designed to apply to a broad range of applications. It may be possible to exceed the limitations of this table by analyzing a specific application with the BC Calc® software.
- Allowable spans and loads shall be adjusted and checked for wind load as required by local building code.

Allowable Uniform Roof Load (in pounds per lineal foot [PLF])

115% and 125% Load Duration

Use of these tables should be limited to roof slopes of 3½" per foot or less.
For steeper slopes, see pages 15-18.

Span Length	BCI® 60 2.0 Series 2 ⁵ / ₁₆ " Flange Width								
	11 ⁷ / ₈ " BCI® 60 2.0			11 ⁷ / ₈ " BCI® 60 2.0			16" BCI® 60 2.0		
	Total Load		Deflect.	Total Load		Deflect.	Total Load		Deflect.
	Snow (115%)	Non-Snow (125%)	L/240	Snow (115%)	Non-Snow (125%)	L/240	Snow (115%)	Non-Snow (125%)	L/240
6	413	449	-	413	449	-	413	449	-
7	354	385	-	354	385	-	354	385	-
8	309	336	-	309	336	-	309	336	-
9	275	299	-	275	299	-	275	299	-
10	247	269	-	247	269	-	247	269	-
11	225	245	-	225	245	-	225	245	-
12	206	224	-	206	224	-	206	224	-
13	190	207	-	190	207	-	190	207	-
14	177	192	-	177	192	-	177	192	-
15	165	179	-	165	179	-	165	179	-
16	154	168	-	154	168	-	154	168	-
17	145	158	-	145	158	-	145	158	-
18	137	149	-	137	149	-	137	149	-
19	130	141	118	130	141	-	130	141	-
20	123	133	102	123	134	-	123	134	-
21	116	116	88	118	128	-	118	128	-
22	101	101	77	112	122	-	112	122	-
23	89	89	68	107	117	99	107	117	-
24	79	79	60	103	112	88	103	112	-
25	70	70	53	99	102	78	99	107	-
26	62	62	47	91	91	69	95	103	93
27	56	56	42	81	81	62	91	99	84
28	50	50	38	73	73	56	88	96	75
29				66	66	50	85	89	68
30				60	60	46	81	81	61
31				54	54	41	73	73	56
32							67	67	51
33							61	61	46
34							56	56	43
35							51	51	39



Allowable Uniform Roof Load
(in pounds per lineal foot [PLF])

115% and 125% Load Duration

Use of these tables should be limited to roof slopes of 3 1/2" per foot or less.
For steeper slopes, see pages 15-18.

Span Length	BCI® 90 2.0 Series 3 1/2" Flange Width														
	11 7/8" BCI® 90 2.0			14" BCI® 90 2.0			16" BCI® 90 2.0			18" BCI® 90 2.0			20" BCI® 90 2.0		
	Total Load		Deflect.	Total Load		Deflect.	Total Load		Deflect.	Total Load		Deflect.	Total Load		Deflect.
	Snow (115%)	Non-Snow (125%)	L/240	Snow (115%)	Non-Snow (125%)	L/240	Snow (115%)	Non-Snow (125%)	L/240	Snow (115%)	Non-Snow (125%)	L/240	Snow (115%)	Non-Snow (125%)	L/240
6	507	551	-	510	555	-	514	559	-	623	677	-	646	702	-
7	434	472	-	437	476	-	441	479	-	534	581	-	553	602	-
8	380	413	-	383	416	-	385	419	-	467	508	-	484	526	-
9	338	367	-	340	370	-	343	372	-	415	451	-	430	468	-
10	304	330	-	306	333	-	308	335	-	374	406	-	387	421	-
11	276	300	-	278	302	-	280	305	-	340	369	-	352	383	-
12	253	275	-	255	277	-	257	279	-	311	338	-	323	351	-
13	234	254	-	235	256	-	237	258	-	287	312	-	298	324	-
14	217	236	-	218	238	-	220	239	-	267	290	-	276	301	-
15	202	220	-	204	222	-	205	223	-	249	271	-	258	280	-
16	190	206	-	191	208	-	192	209	-	233	254	-	242	263	-
17	178	194	-	180	196	-	181	197	-	220	239	-	228	247	-
18	169	183	-	170	185	-	171	186	-	207	225	-	215	234	-
19	160	174	-	161	175	-	162	176	-	196	214	-	204	221	-
20	152	165	148	153	166	-	154	167	-	187	203	-	193	210	-
21	144	157	129	145	158	-	147	159	-	178	193	-	184	200	-
22	138	148	113	139	151	-	140	152	-	170	184	-	176	191	-
23	130	130	100	133	144	-	134	145	-	162	176	-	168	183	-
24	115	115	88	127	138	126	128	139	-	155	169	-	161	175	-
25	103	103	78	122	133	112	123	134	-	149	162	-	155	168	-
26	92	92	70	117	128	100	118	129	-	143	156	-	149	162	-
27	82	82	63	113	118	90	114	124	-	138	150	-	143	156	-
28	74	74	56	106	106	81	110	119	109	133	145	-	138	150	-
29	67	67	51	96	96	73	106	115	98	129	140	127	133	145	-
30	60	60	46	87	87	67	102	111	89	124	135	115	129	140	-
31	55	55	42	79	79	60	99	106	81	120	131	105	125	135	-
32	50	50	38	72	72	55	96	97	74	116	125	96	121	131	120
33				66	66	50	89	89	68	113	114	88	117	127	110
34				60	60	46	81	81	62	105	105	80	114	123	101
35				56	56	42	75	75	57	97	97	74	110	120	93

- Total Load values are limited by shear, moment, or deflection equal to L/180.
- Deflection values (Deflect.) are limited by live load deflection equal to L/240. Check the local building code for other deflection limits that may apply.
- Both the Total Load and Deflection columns must be checked. Where a Deflection value is not shown, the Total Load value will control.

- Table values apply to either simple or multiple span joists. Span is measured center to center of the minimum required bearing length. Analyze multiple span joists with the BC Calc® software if the length of any span is less than half the length of an adjacent span.
- Slope roof joists at least 1/4 inch over 12 inches to minimize ponding.
- Table values assume minimum bearing lengths without web stiffeners for joist

- depths of 16 inches and less. 18 and 20 inch joists require web stiffeners.
- This table was designed to apply to a broad range of applications. It may be possible to exceed the limitations of this table by analyzing a specific application with the BC Calc® software.
- Allowable spans and loads shall be adjusted and checked for wind load as required by local building code.

BCI® Joist Series	Depth [inches]	Weight [plf]	Moment [ft-lbs]	EI x 10 ⁶ [lb-in ²]	K x 10 ⁶ [lbs]	Shear [lbs]	End Reaction [lbs]				Intermediate Reaction [lbs]			
							1/2" Bearing		3/2" Bearing		3/2" Bearing		5/4" Bearing	
							No WS ⁽¹⁾	WS ⁽²⁾	No WS ⁽¹⁾	WS ⁽²⁾	No WS ⁽¹⁾	WS ⁽²⁾	No WS ⁽¹⁾	WS ⁽²⁾
3000 1.7	9 1/2	2.0	2460	160	5.0	1475	950	1125	1125	1275	2100	2350	2525	2750
	11 3/8	2.3	3150	265	6.0	1625	950	1425	1425	1475	2250	2850	2525	3000
	14	2.5	3735	330	8.0	1825	950	1525	1475	1725	2350	3050	2525	3200
6000 1.8	9 1/2	2.2	3165	190	5.0	1575	1175	1375	1375	1425	2400	2650	2700	2750
	11 3/8	2.5	4060	320	6.0	1675	1175	1425	1425	1475	2500	2850	2900	3000
	14	2.7	4815	470	8.0	1925	1175	1525	1525	1725	2600	3150	2925	3200
	16	2.9	5495	635	9.0	2175	1175	1625	1550	1975	2650	3350	2950	3350
6500 1.8	9 1/2	2.3	3505	210	5.0	1575	1175	1375	1375	1425	2400	2650	2700	2750
	11 3/8	2.6	4495	350	7.0	1675	1175	1425	1425	1475	2500	2850	2900	3000
	14	3.0	5330	515	8.0	1925	1175	1525	1525	1725	2600	3150	2925	3200
	16	3.2	6085	695	9.0	2175	1175	1625	1550	1975	2650	3350	2950	3350
60 2.0	11 3/8	2.9	6235	430	7.0	1675	1175	1425	1425	1475	2750	2850	3200	3250
	14	3.1	7440	635	8.0	1925	1175	1525	1525	1725	2750	3450	3200	3650
	16	3.3	8520	860	9.0	2175	1175	1625	1550	1975	2750	3650	3200	3750
90 2.0	11 3/8	3.0	9550	645	7.0	2150	1425	1850	1800	1950	3375	3700	4000	4300
	14	4.1	11390	940	8.0	2350	1450	1950	1850	2150	3400	3850	4100	4450
	16	4.4	13050	1275	9.0	2550	1475	2150	1900	2350	3425	4000	4200	4650
	18	4.6	14690	1660	10.0	2750	N/A ⁽³⁾	2300	N/A ⁽³⁾	2550	N/A ⁽³⁾	4150	N/A ⁽³⁾	4750
	20	4.8	16310	2100	11.0	2850	N/A ⁽³⁾	2500	N/A ⁽³⁾	2650	N/A ⁽³⁾	4300	N/A ⁽³⁾	4850

NOTES:

- (1) No web stiffeners required.
- (2) Web stiffeners required.
 - Moment, shear and reaction values based upon a load duration of 100% and may be adjusted for other load durations.
 - Design values listed are applicable for Allowable Stress Design (ASD).
 - No additional repetitive member increase allowed.

$$\Delta = \frac{5wl^4}{384EI} + \frac{wl^2}{K}$$

Δ = deflection [in]
 w = uniform load [lb/in]
 l = clear span [in]
 EI = bending stiffness [lb-in²]
 K = shear deformation coefficient [lb]

BUILDING CODE EVALUATION REPORT

- ICC-ES®/APA® ESR-1336 (IBC®, IRC®)

BCI® Closest Allowable Nail Spacing

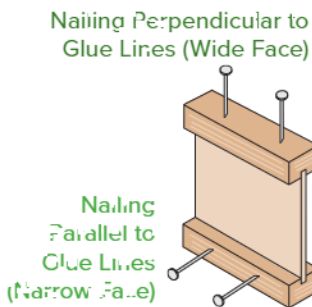

Nail Size	All BCI® Joists			
	Nailing Perpendicular to Glue Line (Wide Face)		Nailing Parallel to Glue Line (Narrow Face)	
	O.C. Spacing [inches]	End of Joist [inches]	O.C. Spacing [inches]	End of Joist [inches]
8d Box (0.118"Ø x 2.5")	2	1 1/2	4	1 1/2
8d Common (0.131"Ø x 2.5")	2	1 1/2	4	3
10d & 12d Box (0.128"Ø x 3", 2.25")	2	1 1/2	4	3
16d Box (0.130"Ø x 3.5")	2	1 1/2	4	3
10d & 12d Common & 16d Sinker (0.148"Ø x 3", 3.25")	3	2	6	4
16d Common (0.162"Ø x 3.5")	3	2	6	4

- If more than one row of nails is used, the rows must be offset at least 1/2 inch.
- Simpson Strong-Tie A35 connectors may be attached to the side of BCI® 60 & 90 joist flanges only. Use nails as specified by Simpson Strong-Tie; do not attach connectors on both sides of a flange at the same location.

BCI® Diaphragm Table ⁽¹⁾

BCI® Series	Diaphragm Capacity ⁽²⁾⁽³⁾ [lb/ft]	
	Unblocked	Blocked
5000	As permitted for 2x framing in building code	320 lb/ft for 6" o.c. nailing @ panel edges 425 lb/ft for 4" o.c. nailing, staggered @ panel edges
6000, 6500	As permitted for 3x framing in building code	360 lb/ft for 6" o.c. nailing @ panel edges 480 lb/ft for 4" o.c. nailing, staggered @ panel edges
60, 90	As permitted for 3x framing in building code	As permitted for 3x framing in building code with nail spacing no closer than 3" o.c.

NOTES:

- (1) See table 6 of ICC-ES®/APA® ESR-1336.
- (2) BCI® joists may be substituted for solid sawn framing in horizontal wood diaphragms as shown in Table 2306.3.1 of the IBC® or Table 23-II-H of the UBC.
- (3) Diaphragm nailing shall not exceed BCI® closest allowable nail spacing limits.

Boise Cascade Rimboard Product Profiles

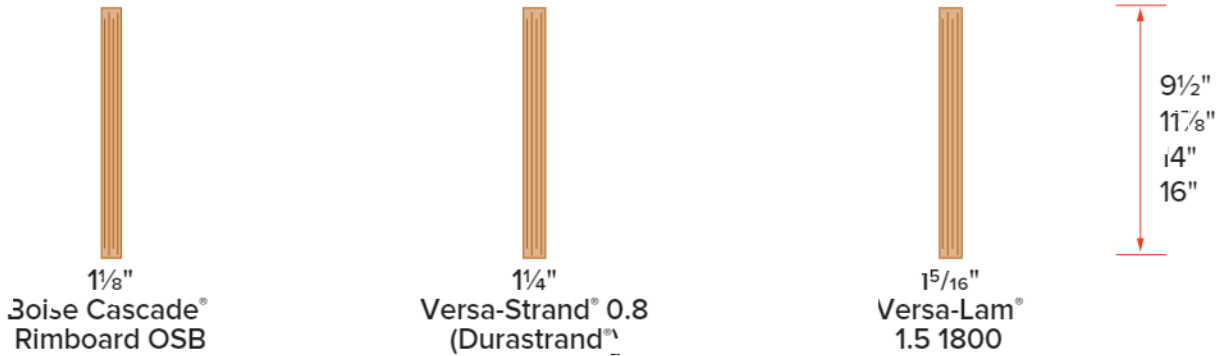

*18 inch and 20 inch deep rimboard are special order products, contact local supplier or Boise Cascade representative for product availability.

★ Product may not be available. Check with supplier or Boise Cascade representative for availability.

F07 Perpendicular

See chart for vertical load capacity.

Min. 8d nails at 6" o.c. per IRC. Connection per design professional or record's specification for shear transfer.

F07A Parallel

See chart for vertical load capacity.

Min. 8d nails at 6" o.c. per IRC. Connection per design professional or record's specification for shear transfer.

F56

Exterior Wall Sheathing Max. 1 5/32" thickness.

Boise Cascade Joists Parallel or perpendicular to rim.

Deck Joist Length Connection

12" or less	2 rows 1/2" bolt or lag screw, 24" o.c. (300 psi max)
12" - 16"	2 rows 1/2" bolt or lag screw, 16" o.c. (450 psi max)

Notes:
 For snow loads greater than 40 psf, and/or dead loads greater than 10 psf, size connection per maximum values shown above.
 Labeled Ledger - Use only fasteners that are approved for use with composite in two directions.

Notes:
 Design of moisture control by others (dry stack urethane core) is shown above.
 • For information on deck joist and connection per IRC section R502.2.3, contact Boise Cascade EWP Engineering.
 • For use of proprietary screws to attach ledger, consult screw manufacturer literature.
 • For further information on residential deck design, see AWU DCA 6, *Prescriptive Residential Wood Deck Construction Guide*.

Boise Cascade Rimboard Properties

Product	Type	Vertical Load Capacity				Maximum Floor Diaphragm Lateral Capacity [lb/ft]	Specific Gravity for Lateral Nail Design	Allowable Design Values			
		Uniform [plf]		Point [lb]				Flexural Stress [lb/in ²]	Modulus of Elasticity [lb/in ²]	Horizontal Shear [lb/in ²]	Compression Perpendicular to Grain [lb/in ²]
		16" Depth & Less	18" & 20" Depth	16" Depth & Less	18" & 20" Depth						
1 1/8" Boise Cascade® Rimboard OSB ⁽²⁾	OSB	4850	3200	3500	3500	200	0.5	Limited span capabilities, see note 2			
1 1/4" Versa-Strand™ 0.8 (Dura-Strand) ⁽³⁾	OSB	5700	3500	3900	5500	240 w/ 8d nails @ 6" o.c. 330 w/ 8d nails @ 4" o.c.	0.5 ⁽⁴⁾	1130	800,000	355	1415
1 5/16" Versa-Lam™ LVL 1.5 1800 ⁽¹⁾	LVL	6000	5450	4450	4450	Permitted per building code for all nominal 2" thick framing blocked and unblocked diaphragms (4" nail spacing & greater)	0.5	1800	1,400,000	225	525

Closest Allowable Nail Spacing - Narrow Face [in]	Product		
	1 1/8" Boise Cascade® Rimboard OSB ⁽²⁾	1 1/4" Versa-Strand™ 0.8 (Dura-Strand) ⁽³⁾	1 5/16" Versa-Lam™ LVL 1.5 1800 ⁽¹⁾
8d Box (0.113"ø x 2.5")	3	4	3
8d Common (0.131"ø x 2.5")	3	4	3
10d & 12d Box (0.128"ø x 3", 3.25")	See publication in note 2 for further nailing information.	4	3
16d Box (0.135"ø x 3.5")		4	3
10d & 12d Common & 16d Sinker (0.148"ø x 3", 3.25")		4	4
16d Common (0.162"ø x 3.5")		6	6

Notes

1. See ICC-ES®/APA® ESR-1040 for further information.
2. See *Performance Rated Rim Boards*, APA® Form No. W345N for further product information.

An Introduction to Versa-Lam® LVL Products



When you specify Versa-Lam® laminated veneer headers/beams, you are building quality into your design. They are excellent as floor and roof framing supports or as headers for doors, windows and garage doors and columns.

Because they have no camber, Versa-Lam® LVL products provide flatter, quieter floors, and consequently, the builder can expect happier customers with significantly fewer call backs.

Versa-Lam® LVL Beam Architectural Specifications

Scope: This work includes the complete furnishing and installation of all Versa-Lam® LVL beams as shown on the drawings herein specified and necessary to complete the work.

Materials: Southern Pine or Douglas fir veneers, laminated in a press with all grain parallel with the length of the member. Glues used in lamination are phenol formaldehyde and isocyanate exterior-type adhesives which comply with ASTM D2559.

Design: Versa-Lam® LVL beams shall be sized and detailed to fit the dimensions and loads indicated on the plans. All designs shall be in accordance with allowable values developed in accordance with ASTM D5456 and listed in the governing

code evaluation service's report and section properties based upon standard engineering principles. Verification of design of the Versa-Lam® LVL beams by complete calculations shall be available upon request.

Drawings: Additional drawings showing layout and detail necessary for determining fit and placement in the buildings are (are not) to be provided by the supplier.

Fabrication: Versa-Lam® LVL beams shall be manufactured in a plant evaluated for fabrication by the governing code evaluation service and under the supervision of a third-party inspection agency listed by the corresponding evaluation service.

Storage and Installation: Versa-Lam® LVL beams, if stored prior to erection, shall be stored on stickers spaced a maximum of 15 ft. apart. Beams shall be stored on a dry, level surface and protected from the weather. They shall be handled with care so they are not damaged.

Versa-Lam® LVL beams are to be installed in accordance with the plans and Boise Cascade EWP's Installation Guide. Temporary construction loads which cause stresses beyond design limits are not permitted. Erection bracing shall be provided to assure adequate lateral support for the individual beams and the entire system until the sheathing material has been applied.

Codes: Versa-Lam® LVL beams shall be evaluated by a model code evaluation service.

Allowable Holes in Versa-Lam® LVL Beams

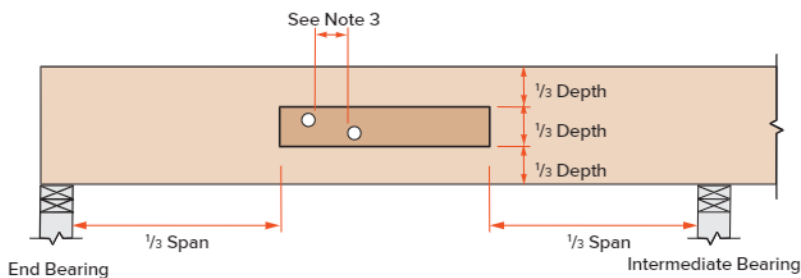

1. Square and rectangular holes are not permitted.
2. Round holes may be drilled or cut with a hole saw anywhere within the shaded area of the beam.
3. The horizontal distance between adjacent holes must be at least two times the size of the larger hole.
4. Do not drill more than three access holes in any four foot long section of beam.

5. The maximum round hole diameter permitted is:

Beam Depth	Max. Hole Diameter
5½"	¾"
7¼"	1"
9¼" and greater	2"

6. These limitations apply to holes drilled for plumbing or wiring access only. The size and location of holes drilled for fasteners are governed by the provisions of the *National Design Specification® for Wood Construction*.
7. Beams deflect under load. Size holes to provide clearance where required.
8. This hole chart is valid for beams supporting uniform load only. For beams supporting concentrated loads or for beams with larger holes, use BC Calc® sizing software (www.BCCalc.com) or contact Boise Cascade EWP Engineering.

BEARING AT CONCRETE/MASONRY WALLS

Provide moisture barrier, and lateral restraint at bearing.

1/2" air space required between concrete and wood.

B01

BEARING FOR DOOR OR WINDOW HEADER

Strap per code if top plate is not continuous over header.

Trimmers.

B02

BEARING TO BEAM CONNECTOR

Verify hanger capacity with hanger manufacturer.

B03

BEARING AT COLUMN

Versa-Lam® LVL column.

Column connector per design or professional record.

B04

SLOPE SEAT CUT

Sloped seat cut. Not to exceed inside face of bearing.

Blocking not shown for clarity.

B06

BEVEL CUT

DO NOT bevel cut Versa-Lam® LVL beyond inside face of wall without approval from Boise Cascade EWP Engineering or BC Calc® software analysis.

B07

BEAM TO CONCRETE/MASONRY WALLS

Wood top plate must be flush with inside of wall.

Hanger.

Moisture barrier between concrete and wood.

B08

BEARING FRAMING INTO WALL

Strap per code if top plate is not continuous.

B09

INSTALLATION NOTES

- Minimum 1/2" air space between beam and wall pocket or adequate barrier must be provided between beam and concrete/masonry.
- Adequate bearing shall be provided. If not shown on plans, please refer to load tables on pages 3-5 of this guide.
- Versa-Lam® LVL beams are intended for interior applications only, and should be kept as dry as possible during construction.
- Continuous lateral support of top of beam shall be provided (side or top bearing framing).

Multiple Member Connectors

Side-Loaded Applications								
Number of Members	Maximum Uniform Side Load [plf]							
	Nailed ^(a)		1/2" Dia. Through Bolt ^(b)			3/8" Dia. Through Bolt ^(c)		
	2 rows 16d Sinkers @ 12" o.c.	3 rows 16d Sinkers @ 12" o.c.	2 rows @ 24" o.c. staggered	2 rows @ 12" o.c. staggered	2 rows @ 24" o.c. staggered	2 rows @ 12" o.c. staggered	2 rows @ 6" o.c. staggered	2 rows @ 6" o.c. staggered
1 3/4" Versa-Lam® LVL (Depths of 18" and less)								
2	470	705	505	1010	2020	560	1120	2245
3 ^(d)	350	525	375	755	1515	420	840	1685
4 ^(e)	Use bolt schedule	335	670	1345	370	745	1495	
3 1/2" Versa-Lam® LVL								
2 ^(d)	Use bolt schedule		855	1715	N/A	1125	2250	N/A

1. Design values apply to common bolts that conform to ANSI/ASME standard B18.21-1981 (ASTM A307 Grades A&B, SAE J429 Grades 1 or 2, or higher). A washer not less than a standard cut washer shall be between the wood and the bolt head and between the wood and the nut. The distance from the edge of the beam to the bolt holes must be at least 2" for 1/2" bolts and 2 1/2" for 3/8" bolts. Bolt holes shall be the same diameter as the bolt.

2. The nail schedules shown apply to both sides of a 3-member beam.

3. 16d box nails = 0.135" diameter x 3.5" length, 16d sinker nails = 0.148" diameter x 3.25" length.

4. 1 1/4" wide beams must be top-loaded or loaded from both sides; lesser side shall be no less than 25% of opposite side.

Top-Loaded Applications			
For top-loaded beams and beams with side loads less than shown in Side-Loaded Applications table above:			
Ply	Depth	Nailing ^(a)	Maximum Uniform Load From One Side
(2) 1 3/4" plies	Depths 11 3/8" & less	2 rows 16d box/sinker nails @ 12" o.c.	400 plf
	Depths 14" - 18"	3 rows 16d box/sinker nails @ 12" o.c.	600 plf
	Depth = 24"	4 rows 16d box/sinker nails @ 12" o.c.	800 plf
(3) 1 3/4" plies ^(b)	Depths 11 3/8" & less	2 rows 16d box/sinker nails @ 12" o.c.	300 plf
	Depths 14" - 18"	3 rows 16d box/sinker nails @ 12" o.c.	450 plf
	Depth = 24"	4 rows 16d box/sinker nails @ 12" o.c.	600 plf
(4) 1 3/4" plies	Depths 18" & less	2 rows 1/2" bolts @ 24" o.c., staggered	335 plf
	Depth = 24"	3 rows 1/2" bolts @ 24" o.c., staggered every 8"	505 plf
	Depths 18" & less	2 rows 1/2" bolts @ 24" o.c., staggered	255 plf
(2) 3 1/2" plies	Depth 20" - 24"	3 rows 1/2" bolts @ 24" o.c., staggered every 8"	1285 plf

1. The nail schedules shown apply to both sides of a 3-member beam.

2. 16d box nails = 0.135" diameter x 3.5" length, 16d sinker nails = 0.148" diameter x 3.25" length.

3. Beams wider than 1 1/4" must be designed by the engineer or designer.

4. All values in these tables may be increased by 15% for snow loads and by 25% for non-snow loads. Conditions where the building code allows.

5. Use allowable load tables or BC Calc software to size beams.

6. An equivalent specific gravity of 0.3 may be used when designing specific connections with Versa-Lam®.

7. Connection values are based upon the NDS, 2010 Edition.

8. FastenMaster i-Bo® or Simpson Strong-Tie i-Bo® are approved US-WS screws must be used to connect multiple members. Versa-Lam® LVL beams, contact Boise Cascade EWP Engineering for further information.

Designing Connections For Multiple Versa-Lam® LVL Members

When using multiple ply Versa-Lam® LVL beams to create a wider member, the connection of the plies is as critical as determining the beam size. When side loaded beams are not connected properly, the inside plies do not support their share of the load and thus the load-carrying capacity of the full member decreases significantly. The following is an example of how to size and connect a multiple-ply Versa-Lam LVL floor beam.

Given: Beam shown below is supporting residential floor load (40 psf live load, 10 psf dead load) and is spanning 16' 0". Beam depth is limited to 1'.

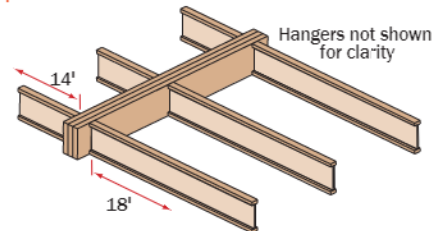

Find: A multiple 1 3/4" ply Versa-Lam® LVL that is adequate to support the design loads and the member's proper connection schedule.

- Calculate the tributary width that beam is supporting:
 $14' / 2 + 18' / 2 = 16'$
- Use PLF tables on pages 3-5 of this guide or BC Calc® to size beam.
A Triple Versa-Lam® LVL 2.12800 1 3/4" x 14" is required to adequately support the design loads.
- Calculate the maximum plf load from one side, the right side in this case:
 $\text{Max Side Load} = (18' / 2) \times (40 + 10 \text{ psf}) = 450 \text{ plf}$
- Go to the **Multiple Member Connection Tables, Side-Loaded Applications, 1 3/4" Versa-Lam® LVL, 3 members**.
- The proper connection schedule must have a capacity greater than the max. side load:
Nailed: 3 rows 16d sinkers @ 12" o.c.
525 plf is greater than 450 plf OK
Bolts: 1/2" diameter 2 rows @ 12" staggered:
755 plf is greater than 450 plf OK

Closest Allowable Nail Spacing

Versa-Lam® LVL Products Nail Size	Nailing Parallel to Glue Lines (Narrow Face)						Nailing Perpendicular to Glue Lines (Wide Face)	
	Versa-Lam® LVL 1.5E 1800 1 5/16"		Versa-Lam® LV 1 3/4"		Versa-Lam® LVL 3 1/2" & Wider		All Products	
	O.C. [in.]	End [in.]	O.C. [in.]	End [in.]	O.C. [in.]	End [in.]	O.C. [in.]	End [in.]
8d Box (0.113"Ø x 2.5")	3	1 1/2	2	1	2	1/2	2	1/2
8d Common (0.131"Ø x 2.5")	3	2	3	2	2	1	2	1
10d & 12d Box (0.128"Ø x 3", 3.25")	3	2	3	2	2	1	2	1
16d Box (0.135"Ø x 3.5")	3	2	3	2	2	1	2	1
10d & 12d Common & 16d Sinker (0.148"Ø x 3", 3.25")	4	3	4	3	2	2	2	2
16d Common (0.162"Ø x 3.5")	6	4	6	3	2	2	2	2

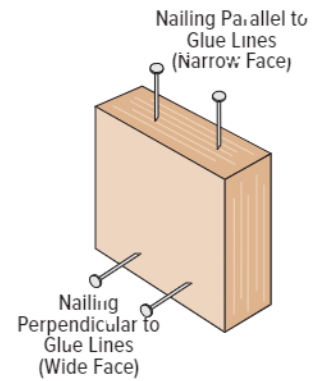

1) For 1 3/4" thickness and greater, 2 rows of nails (such as for a metal strap) are allowed (use 1/2" minimum offset between rows and stagger nails).

- Offset and stagger nail rows from floor sheathing and wall sole plate.
- Simpson Strong-Tie A-5 and L-T4 connectors may be attached to the side Versa-Lam® LVL. Versa-Rim® LVL Use nails as specified by Simpson Strong-Tie

Versa-Lam® LVL Design Values

Grade	Width [in]	Depth [in]	Weight [lb/ft]	Allowable Shear [lb]	Allowable Moment [ft-lb]	Moment of Inertia [in ⁴]	Grade	Width [in]	Depth [in]	Weight [lb/ft]	Allowable Shear [lb]	Allowable Moment [ft-lb]	Moment of Inertia [in ⁴]
Versa-Lam® 1.5E 1800	1 5/16	9 1/2	3.2	1,870	3,039	93.8	Versa-Lam® 2.1E 3100	3 1/2	5 1/2	4.5	3,653	4,971	48.5
		11 3/8	4.0	2,338	4,632	183.2			7 1/4	6.5	4,821	8,377	111.1
		14	4.7	2,756	6,322	300.1			9 1/4	8.3	6,151	13,272	230.8
		16	5.4	3,150	8,136	448.0			9 1/2	8.5	6,318	13,958	250.1
		18	6.1	3,544	10,163	637.9			11 1/4	10.1	7,481	19,210	415.3
		20	6.7	3,938	12,401	875.0			11 3/8	10.7	7,897	21,275	488.4
									14	12.6	9,310	29,035	800.3
Versa-Lam® 1.8E 2400	1 1/2	3 1/2	1.3	998	702	5.4		16	14.4	10,640	37,364	1134.7	
		5 1/2	2.1	1,568	1,649	20.8		18	16.2	11,970	46,674	1701.0	
		7 1/4	2.8	2,066	2,779	47.6		20	18.0	13,300	56,952	2333.3	
		9 1/4	3.6	2,636	4,404	98.9		5 1/4	7.1	5,237	6,830	63.3	
		9 1/2	3.7	2,708	4,631	107.2		5 1/2	7.4	5,486	7,457	72.8	
		11 1/4	4.3	3,206	6,374	178.0		7 1/4	9.8	7,232	12,566	166.7	
		11 3/8	4.6	3,384	7,059	209.3		9 1/4	12.5	9,227	19,908	346.3	
Versa-Lam® 2.1E 2800	1 3/4	14	5.4	3,990	9,634	343.0	9 1/2	12.8	9,476	20,937	375.1		
		16	6.2	4,560	12,397	512.0	11 1/4	15.2	11,222	28,814	622.9		
		5 1/2	2.5	1,829	2,245	24.3	11 3/8	16.0	11,845	31,913	732.6		
		7 1/4	3.3	2,411	3,783	55.6	14	18.9	13,965	43,552	1200.5		
		9 1/4	4.2	3,076	5,994	115.4	16	21.6	15,960	56,046	1792.0		
		9 1/2	4.3	3,159	6,304	125.0	18	24.3	17,955	70,011	2551.5		
		11 1/4	5.1	3,741	8,675	207.6	20	27.0	19,950	85,428	3500.0		
		11 3/8	5.3	3,948	9,608	244.2	24	32.4	23,940	120,549	6048.0		
		14	6.3	4,655	13,112	400.2	7	9 1/4	16.6	12,303	26,544	461.7	
		16	7.2	5,320	16,874	597.3	9 1/2	17.1	12,635	27,916	500.1		
18	8.1	5,985	21,079	850.5	11 1/4	20.2	14,963	38,419	830.6				
					11 3/8	21.4	15,794	42,550	976.8				
					14	25.2	18,620	58,069	1600.7				
					16	28.8	21,280	74,728	2389.3				
					18	32.4	23,940	93,348	3402.0				
					20	36.0	26,600	113,904	4666.7				
					24	43.2	31,920	160,732	8064.0				

Versa-Lam® LVL Allowable Stress Values

Design Property	Grade	Modulus of Elasticity True (Shear-Free)	Modulus of Elasticity Apparent	Modulus of Elasticity for Stability	F _b (psi) ⁽²⁾⁽³⁾	Horizontal Shear F _v (psi) ⁽²⁾⁽⁴⁾	Tension Parallel to Grain F _t (psi) ⁽²⁾⁽⁵⁾	Compression Parallel to Grain F _c (psi) ⁽²⁾	Compression Perpendicular to Grain F _{c⊥} (psi) ⁽⁶⁾⁽⁷⁾	Equivalent Specific Gravity for Fastener Design (γ _G)
		E (x 10 ³ psi) ⁽¹⁾⁽⁷⁾	E _{app} (x 10 ³ psi) ⁽⁸⁾	E _{min} (x 10 ⁶ psi) ⁽⁹⁾⁽¹⁰⁾						
Versa-Lam® LVL Beams 1 3/4"	2.1E 2800	2.1	2.0	1.1	2800	285	1950	3000	750	0.5
Versa-Lam® LVL Beams 3 1/2" & Wider	2.1E 3100	2.1	2.0	1.1	3100	285	1950	3000	750	0.5
Versa-Lam® LVL Studs	1.8E 2400	1.8	1.7	0.9	2650	285	1500	3000	750	0.5
Versa-Lam® LVL Columns	1.8E 2650	1.8	1.7	0.9	2650	285	1650	3000	750	0.5

1. This value cannot be adjusted for load duration.
 2. This value is based upon a load duration of 100% and F_b, F_v be adjusted for other load durations.
 3. Fiber stress bending value shall be multiplied by the depth factor, (12/d)^{1/4} where d = member depth, in. [in].
 4. Stress applied perpendicular to the glue lines.
 5. Tension value shall be multiplied by a length factor, (4/L)^{1/2} where L = member length [ft]. Use L = ∞ for members less than four feet long.
 6. Stress applied parallel to the glue lines.
 7. True or shear-free modulus of elasticity does not account for shear deformation.
 8. E_{min} is the reference modulus of elasticity for beam and column stability calculations. It is calculated using E_{app} in accordance with Appendix U of the 2018 NDS. When calculating E_{min}, the coefficient of modulus of elasticity, COV_E, may be taken as 0.10, and the adjustment factor to convert to a pure bending basis may be taken as 1.05.
- * Design properties are limited to dry conditions of use where the maximum moisture content of the material will not exceed 16%.

Versa-Lam® LVL 1.8 2650 Columns

Column Length [ft]	3½" Allowable Axial Load (lb)								
	3½" x 3½"			3½" x 5¼"			3½" x 7"		
	100%	115%	125%	100%	115%	125%	100%	115%	125%
4	14,700	16,090	13,930	22,070	24,165	25,450	29,450	32,240	33,920
5	14,270	13,150	13,660	18,425	19,740	20,515	24,580	26,530	27,565
6	10,080	10,450	10,980	15,140	15,995	16,495	20,195	21,335	22,000
7	8,310	8,705	8,950	12,450	13,075	13,415	16,650	17,335	17,890
8	6,930	7,205	7,370	10,405	10,825	11,070	13,880	14,440	14,760
9	5,840	6,050	6,160	8,770	9,080	9,260	11,700	12,115	12,350
10	4,930	5,135	5,225	7,480	7,715	7,850	9,975	10,290	10,470
11	4,290	4,410	4,480	6,445	6,625	6,730	8,595	8,835	9,075
12	3,730	3,825	3,830	5,600	5,745	5,830	7,475	7,665	7,775
13	3,270	3,350	3,390	4,915	5,030	5,095	6,555	6,710	6,795
14	2,890	2,950	2,990	4,340	4,435	4,490	5,790	5,915	5,990

Column Length [ft]	5¼" Allowable Axial Load (lb)												7" Allowable Axial Load (lb)						
	5¼" x 5¼"			5¼" x 5½"			5¼" x 7"			5¼" x 7¼"			7" x 7"			7" x 7¼"			
	100%	115%	125%	100%	115%	125%	100%	115%	125%	100%	115%	125%	100%	115%	125%	100%	115%	125%	
6	33,070	36,220	38,110	34,670	37,950	39,930													
7	29,420	31,730	33,085	30,830	33,240	34,660													
8	25,875	27,570	28,565	27,110	28,880	29,930	34,525	36,790	38,115	35,760	38,090	39,480							
9	22,690	23,970	24,715	23,770	25,110	25,900	30,275	31,985	32,980	31,360	33,130	34,160							
10	19,930	20,920	21,495	20,880	21,920	22,520	26,600	27,920	28,685	27,550	28,920	29,710							
11	17,585	18,375	18,820	18,420	19,250	19,720	23,465	24,510	25,125	24,310	25,400	26,010							
12	15,590	16,220	16,585	16,340	16,990	17,380	20,805	21,650	22,130	21,550	22,420	22,930							
13	13,895	14,410	14,700	14,560	15,100	15,400	18,545	19,225	19,620	19,210	19,920	20,320							
14	12,450	12,870	13,115	13,040	13,480	13,740	16,615	17,180	17,500	17,210	17,790	18,130	33,260	34,825	35,740	34,460	36,070	37,030	
15	11,210	11,560	11,760	11,740	12,110	12,320	14,960	15,425	15,695	15,490	15,980	16,260	30,325	31,645	32,395	31,410	32,780	33,560	
16	10,135	10,430	10,600	10,620	10,930	11,110	13,525	13,920	14,150	14,010	14,420	14,650	27,720	28,835	29,490	28,710	29,870	30,540	
17	9,205	9,455	9,600	9,650	9,910	10,060	12,285	12,620	12,810	12,730	13,070	13,270	25,415	26,375	26,920	26,330	27,320	27,880	
18	8,395	8,610	8,735	8,800	9,020	9,150	11,205	11,495	11,655	11,610	11,900	12,070	23,370	24,195	24,665	24,210	25,060	25,560	
19	7,685	7,870	7,975	8,050	8,250	8,360	10,260	10,505	10,645	10,620	10,880	11,030	21,550	22,270	22,670	22,320	23,070	23,490	
20	7,060	7,220	7,310	7,400	7,560	7,660	9,420	9,635	9,760	9,760	9,980	10,110	19,925	20,550	20,910	20,640	21,280	21,660	
21	6,505	6,645	6,725	6,820	6,960	7,050	8,680	8,870	8,980	8,990	9,190	9,300	18,475	19,020	19,330	19,130	19,700	20,020	
22													17,165	17,650	17,925	17,780	18,280	18,570	
23													15,990	16,420	16,660	16,560	17,010	17,260	
24													14,930	15,310	15,525	15,460	15,860	16,080	

- Table assumes that the column is braced at column ends only. Effective column length is equal to actual column length.
- Allowable loads are based upon one-piece (solid) column members used in dry service conditions. BC Calc® sizing software (www.BCCalc.com) may be used for multi-piece column design.
- Allowable loads are based on an eccentricity value equal to 0.167 multiplied by either the column thickness or width (worst case).
- Allowable loads are based on axial loaded columns using the design provisions of the 2018 National Design Specification (NDS) for Wood Construction. Table capacity values based upon a buckling length coefficient, K_e , equal to 1.0 (rotation free, translation fixed at each column end per NDS Appendix G). A K_e coefficient of 1.0 conservatively models typical wood column applications. For other end fixity conditions, contact Boise Cascade EWP Engineering. For side or other combined bending and axial loads, see provisions in 2018 NDS.
- Load values are not shown for short lengths due to loads exceeding common connector capacities. Load values are not shown for longer lengths if the controlling slenderness ratio exceeds 50 (per NDS).
- Lateral loads (wind loading) are not considered in this table. BC Calc® sizing software (www.BCCalc.com) may be used for out of plane lateral load column application design.

Versa-Stud® LVL 1.8E 2400

Reference Design Values

Product	Bending F_b [psi]	Compression Parallel to Grain F_c [psi]	Compression Perp to Grain $F_{c\perp}$ [psi]	Modulus of Elasticity - Apparent E [psi]	Horizontal Shear F_v [psi]
Versa-Stud® 1.8E 2400 1½" x 5½"	2617	3000	450	1,700,000	285
Douglas-Fir # 2 Grade 2 x 6	1170	1350	625	1,600,000	180
Spruce Pine Fir (North) # 1 / 2 Grade 2 x 6	1138	1150	425	1,400,000	135
Hem-Fir # 2 Grade 2 x 6	1105	1300	405	1,300,000	150
Western Woods # 2 Grade 2 x 6	878	900	335	1,000,000	135

- Design values are for loads applied to the narrow face of the studs.
- Dimension lumber values taken from 2018 NDS supplement: Design Values for Wood Construction (per 2018 IBC®/IRC®).
- Repetitive member factors have not been applied to the bending values. Depth (size) factors per ICC-ES®/APA® ESR-1040 and 2018 NDS have been applied to the corresponding bending values.

For further design information, please see Versa-Stud 1.8E 2400 western installation guide.



BC Framer® helps customers create floor and roof framing layouts quickly. This easy-to-use computer-aided 3D drafting program frames layouts and creates piece and price reports. It also draws framing drawings that use Boise Cascade's engineered wood products (EWP) and develops schedules. BC Framer's editing and drawing tools allow flexibility when modifying framing layouts. You can also customize the layout drawing with framing details, notes, symbols, and accessories.

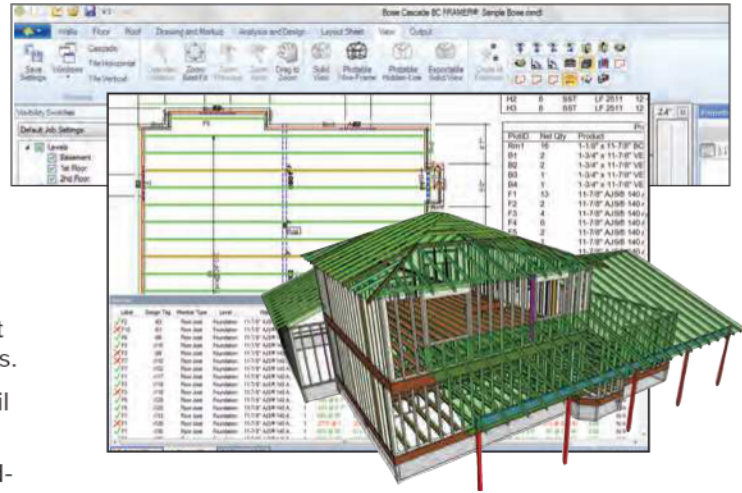

Information can also be obtained at 1-800-405-5969 or email us at EWPSupport@BC.com.

Technical Specs: This program is designed to work on stand-alone computers.

RECOMMENDED HARDWARE

- CPU: 2.8GHz 6th Gen+ Core i7 or Xeon v4+
- L₂ Cache: 3MB/Core
- RAM: 16GB
- Video: Full support for DirectX 9, Single monitor 512MB; Dual monitor 1GB (Resolution 1280x768 Minimum)
- Free Storage: 80GB (average 3,000-8,000 jobs)
- Operating Systems: Windows 10 (Pro or Enterprise Edition 64-bit)*, Windows 8.1 (Professional Edition 64-bit), Windows 7 (Professional Edition 64-bit),

*Apple Mac or Windows Emulator not supported
Actual specifications vary by user and will be assessed prior to installation.

BC Calc® Sizing Software

BC Calc® is now a web-based application available at www.bccalc.com and can be used on Windows or Apple operating systems via Internet Explorer, Edge, Chrome or Safari browsers as well as on iOS and Android tablets. An offline version is available to BC Connect™ or registered BC Calc® users for use without an internet connection or in cases of limited connection availability it can be downloaded once users have signed in to the application.

In addition to BCi® & AJS® Joists, Versa-Lam® LVL, and BOISE GLULAM®, BC Calc® also offers the analysis of solid sawn lumber and timber members. This BC Calc® is the only program needed to analyze structural wood members.



Boise Cascade has provided BC Calc® free of charge to the design community since 1994.

COMPUTER REQUIREMENTS

PC with any current version of MS Windows®, along with an internet connection. For questions regarding BC Calc®, call 1-800-405-5969 or email EWPSupport@BC.com.

To Download BC CALC US, www.bccalc.com

The screenshots show the BC Calc software interface. The top window displays a list of products for selection, including various sizes of Boise Glulam. The middle window shows analysis results for a selected product, including control type, values, and percentages. The bottom window displays a detailed reaction summary table for a specific beam.

Reaction	Live	Dead	Wind	Roof Live
RL 4'	4,125.0	2,044.0		
RL 31.2'	4,115.0	7,026.0		

Tag	Description	Load Type	Ref. Start	End	100%	90%	100%	100%	100%	100%	100%	100%
1	Standard Load	Live Area (Roof)	L	00-00-00	33-06-00		15	33				14-00-00

Control	Value	% Allowable	Code	Location	Discipline
Pos. Moment	80,526 ft-lb	69.2%	115%	4	16-09-04
End Shear	6,537 lbs	32.7%	115%	4	05-03-08
Total Load Defl.	0.206 (1.804")	65.5%	n/a	4	16-09-04
Live Load Defl.	0.130 (1.201")	72.6%	n/a	5	16-09-04
Span / Depth	19.9	n/a	n/a	0	00-00-00

Single Joist - Top Flange Single Joist - Face Mount Face Mount Skewed 45° Joist Hanger

Single Joist - Top Flange						Single Joist - Face Mount						Face Mount Skewed 45° Joist Hanger					
Joist Depth	BCI*	Hanger	Capacity [lbs]	Nailing		Joist Depth	BCI*	Hanger	Capacity [lbs]	Nailing		Joist Depth	BCI*	Hanger	Capacity [lbs]	Nailing	
				Header	Joist					Header	Joist					Header	Joist
9 1/2"	5000 1.7	TFL2095	993	(6) 10d	2-10dx1 1/2"	9 1/2"	5000 1.7	THF20925	910	(8) 10d	2-10dx1 1/2"	9 1/2"	5000 1.7	SKH2020L/R	1153	(14) 10d	10-10dx1 1/2"
	6000 1.8	TFL2395	1225	(6) 10d	2-10dx1 1/2"		6000 1.8	THF23925	1275	(12) 10d	2-10dx1 1/2"		6000 1.8	SKH2320L/R	1384	(14) 10d	10-10dx1 1/2"
	6500 1.8	TFL2595	1225	(6) 10d	2-10dx1 1/2"		6500 1.8	THF26925	1275	(12) 10d	2-10dx1 1/2"		6500 1.8	SKH2520L/R	1384	(14) 10d	10-10dx1 1/2"

Double Joist - Top Flange Double Joist - Face Mount Variable Pitch Joist Connector

Double Joist - Top Flange						Double Joist - Face Mount						Variable Pitch Joist Connector					
Joist Depth	BCI*	Hanger	Capacity [lbs]	Nailing		Joist Depth	BCI*	Hanger	Capacity [lbs]	Nailing		Joist Depth	BCI*	Hanger	Capacity [lbs]	Fastener	
				Header	Joist					Header	Joist					Top Plate	Rafter
9 1/2"	5000 1.7	THO2095-2	2330	(10) 16d	6-10d	9 1/2"	5000 1.7	THF20925-2	1390	(12) 10d	6-10d	9 1/2"	5000 1.7	TM 21	1125	(6) 10d	4-10dx1 1/2"
	6000 1.8	THO2395-2	2825	(10) 10d	6-10d		6000 1.8	THF23925-2	1625	(14) 10d	6-10d		6000 1.8	TMP23	1375	(6) 10d	4-10dx1 1/2"
	6500 1.8	THO2595-2	2650	(10) 16d	6-10d		6500 1.8	THF26925-2	1390	(12) 10d	6-10d		6500 1.8	TMP25	1375	(6) 10d	4-10dx1 1/2"

Adjustable Height Joist Hanger Field Slope and Skew Joist Hanger

Adjustable Height Joist Hanger						Field Slope and Skew Joist Hanger					
Joist Depth	BCI*	Hanger	Capacity [lbs]	Nailing		Joist Depth	BCI*	Hanger	Capacity [lbs]	Nailing	
				Header	Joist					Header	Joist
9 1/2"	5000 1.7	-	-	-	-	9 1/2"	5000 1.7	LSSH20	1140	(10) 10d	7-10dx1 1/2"
	6000 1.8	MSH23.8	1438	(6) 10d	4-10dx1 1/2"		6000 1.8	LSSH23	1140	(10) 10d	7-10dx1 1/2"
	6500 1.8	MSH318	1381	(6) 10d	4-10dx1 1/2"		6500 1.8	LSSH25	1412	(14) 10d	12-10dx1 1/2"

Mitek For more information, contact Mitek USP Structural Connectors at 1-800-328 5934 or Mitek-US.com

- General Note:**
- Skewed hangers require web stiffeners at joist ends. Web stiffeners may be required for non-skewed hangers by Boise Cascade.
 - Capacities will vary slightly if different nailing criteria and/or support conditions contact supplier or USP Structural Connectors for further information.
 - Capacity values shown are either hanger capacity values (see support requirements below) or joist reaction capacities - whichever is less.
 - All capacity values are down wind loads at 100% load duration.
 - Use sloped seat hangers and beveled web stiffeners when BCI joist slope exceeds ¼" per foot.
 - Leave 1/8" clearance (1/8" maximum) between the end of the supported joist and the head of the hanger.
 - For BCI joist applications, consult Mitek US for capacity reduction.

- Support Requirements**
- Support material assumed to be Boise Cascade structural composite lumber or sawn lumber (Douglas fir or southern pine species)
 - Minimum support width for single- and double joist top mount hangers is 3" (1 1/2" for THO hangers).
 - Minimum support width for face mount hangers with 10d and 16d nails is 1 3/4" and 2", respectively.

FASTER. STRONGER. EASIER.



Boise Cascade®

Lifetime Guaranteed Quality and Performance

Boise Cascade warrants its BCI® Joist, Versa-Lam® LVL and ALLJOIST® products to comply with our specifications, to be free from defects in material and workmanship, and to meet or exceed our performance specifications for the normal and expected life of the structure when correctly stored, installed and used according to our Installation Guide.

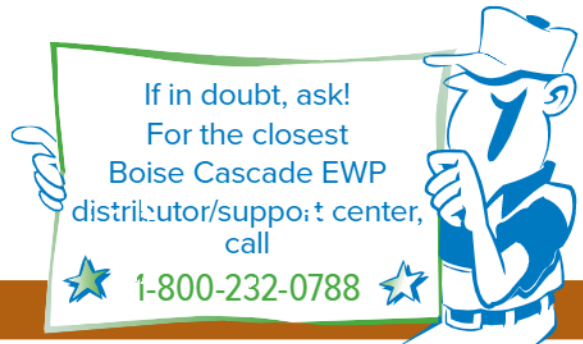

For information about
Boise Cascade's Engineered Wood Products, visit our website at
www.BC.com/ewp

Your Dealer is:

If no dealer is listed, call 1-800-232-0788



Boise Cascade®
ENGINEERED WOOD PRODUCTS