



**Boise Cascade**  
Engineered Wood Products

# VERSA-STUD® 1.7 2400 WALL GUIDE

for product manufactured in White City, Oregon

*Stronger  
and  
Stiffer  
for  
Tall Walls  
and  
High Wind  
Loads*

*Straighter  
for  
Cabinet  
and  
Tile Walls*

Better homes from better builders —  
by design . . .  
with **VERSA-STUD®** wall framing

VERSA-STUD 1.7 2400  
WALL GUIDE WEST  
12/04/2008 r 03/15/2013

# VERSA-STUD® 1.7 2400

## Engineered Studs for Tall Walls

VERSA-STUD® 1.7 2400 laminated veneer lumber wall framing is engineered for the high quality builder who wants . . .

- Stronger walls to resist wind loads
- Stiffer walls for a solid feel
- Straight walls for a high quality finish



Long, continuous **VERSA-STUD® 1.7 2400** wall framing will provide superior strength and stiffness in any tall wall application. **VERSA-STUD® 1.7 2400** wall framing provides more resistance to wind pressure than walls framed with dimension lumber and eliminates the hinge created by platform framing. 1 1/2" x 5 1/2" **VERSA-STUD® 1.7 2400** wall framing has two times more bending strength than No. 2 DF 2x6 studs.

Building Code Approved  
for Both Prescriptive and  
Engineered Wall Stud Design

\* 9 1/4" and 11 1/4" depths may be available. Check with supplier or Boise Cascade EWP representative for availability.

Table of Contents

Product profile .....	2	VERSA-STUD® & VERSA-LAM® Column Details .....	12
Prescriptive Design .....	3	VERSA-LAM® 1.7 2450 Exterior Wall Column Table .....	13
Engineered Design Assumptions for Load Tables .....	4	Connectors .....	14
Wall Deflection .....	5	Connectors / Allowable Holes and Notches .....	15
Determining Wind Load .....	5	Design Properties .....	16
Wind Load Definitions .....	7	VERSA-STUD® Wall Sheathing Nailing .....	17
VERSA-STUD® & VERSA-LAM® Column Design Example .....	8	3C COLUMN™ Software .....	18
Stud Load Tables - VERSA-STUD® 1.7 2400 1 1/2" x 3 1/2" .....	9	Computer Software .....	19
Stud Load Tables - VERSA-STUD® 1.7 2400 1 1/2" x 5 1/2" .....	10	Information and Support, SFI, Lifetime Guarantee .....	Back cover
Stud Load Tables - VERSA-STUD® 1.7 2400 1 1/2" x 7 1/4" .....	11		

VERSA-STUD® may be used as wall studs in accordance with the prescriptive requirements in section 2308.9 of the IBC and section R602 of the IRC. The table below lists span and spacing limits for prescriptive stud design. Prescriptive design is valid for structures where the wind load does not exceed 110 mph (100 mph in hurricane-

prone regions), the ground snow load does not exceed 70 psf, dead loads on floors or roof do not exceed 20 psf, and several other provisions listed in both building codes. The building design professional of record shall determine whether the structure qualifies for prescriptive design.

Prescriptive Wall Stud Limits for Conventional Construction			
Wall Type	Stud Size	Stud Height	Max O.C. Spacing
Bearing wall supporting roof and ceiling only	1½" x 3½"	10'	24"
	1½" x 5½"	10'	24"
Bearing wall supporting one floor only	1½" x 3½"	10'	24"
	1½" x 5½"	10'	24"
Bearing wall supporting one floor, roof and ceiling	1½" x 3½"	10'	16"
	1½" x 5½"	10'	24"
Bearing wall supporting two floors, roof and ceiling	1½" x 3½"	10'	—
	1½" x 5½"	10'	16"
Non-bearing walls	1½" x 3½"	14'	24"
	1½" x 5½"	20'	24"



• Limits per IRC Table R602.3(5)

## Using VERSA-STUD® for Cabinet and Tile Walls

Dimension lumber can exceed 30% moisture content. Wood dries to a moisture content of 10-12% once the building is finished. Shrinkage and warping of 2x studs is a problem in walls where cabinets are hung or tile is installed. Though 2x studs cost less, added labor from shimming cabinets, straightening walls and drywall repairs can quickly add up. VERSA-STUD® eliminates these issues providing a straight and true wall every time.

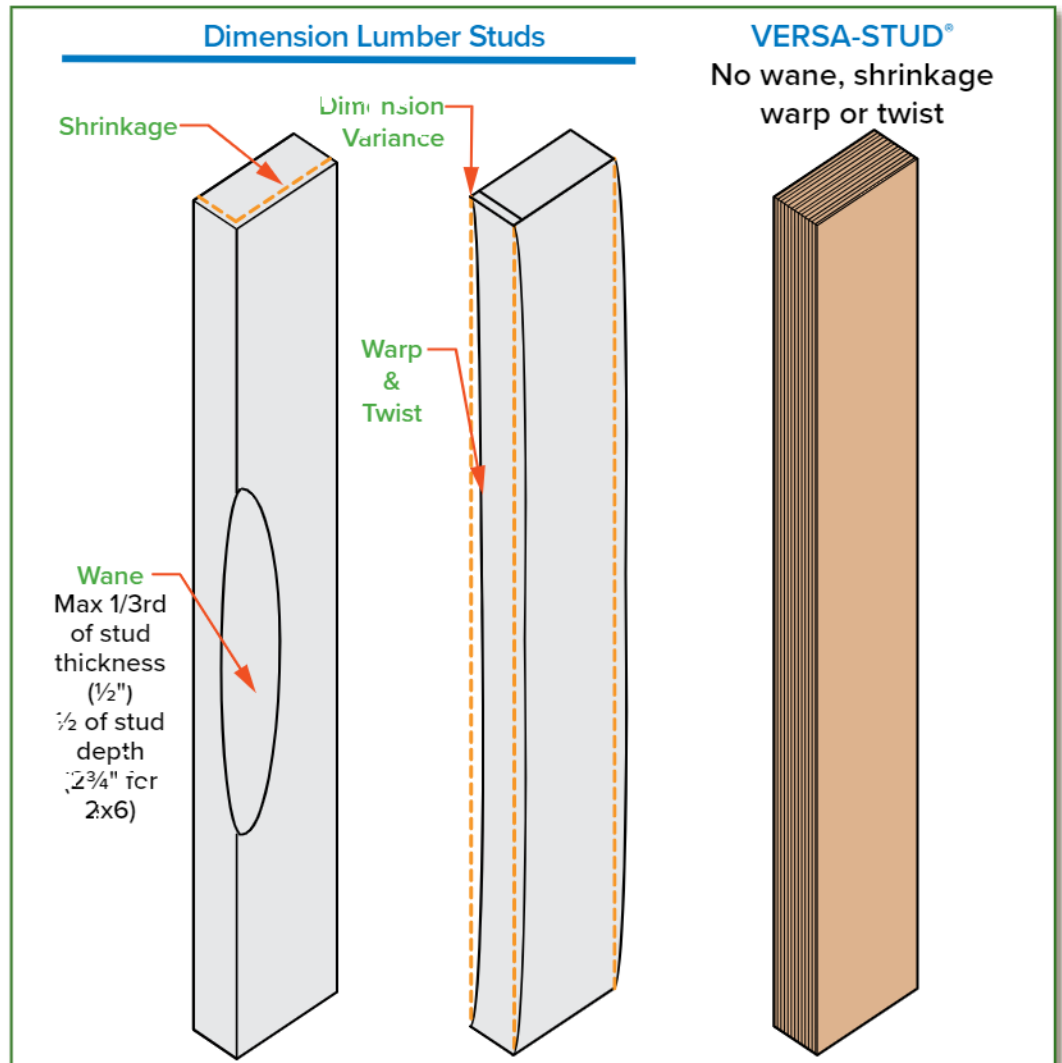

Load table values are based upon axial loads applied at the top of the stud and lateral wind loads perpendicular to the wall (out of plane loading). Lateral loads parallel to the wall (in-plane loading), caused by seismic and wind, shall be designed by the project's design professional of record.

Allowable loads based upon the design provisions of the National Design Specification for Wood Construction (NDS), 2005 edition.

Studs receive axial load concentrically through a double top plate and thus no eccentricity is assumed.

A buckling length coefficient  $K_e$  (based on the fixity of stud ends) is 1.0.

Load table values based upon assumption that stud walls have structural sheathing applied to one side or a combination of non-structural sheathing on the exterior side and gypsum wallboard on the interior side.

Blocking between studs required at a maximum spacing of 8'-0".

The repetitive member factor of 1.04 has been applied to the VERSA-STUD® allowable bending stress.

Wind load duration factor  $C_D = 1.6$ .

Maximum rough opening height of adjoining openings shall not exceed 84".

Double stud members and larger members shown in tables are assumed to be located between openings or at sides of openings. Single stud members shown in tables shall not be used between openings.



## Load Combinations

The allowable design loads shown in this guide are based upon load combination equations for allowable stress design (IBC 06 Section 1605.3.1). Specifically for wall applications.

1. roof dead load + roof live or snow load
2. roof dead load + 0.75 x (roof live or snow load + wind load)
3. 0.6 x dead load + wind load

Since the chances are extremely remote that the maximum roof live or snow load will be present at the same time as a maximum wind load, the IBC allows for a 25% reduction in both loads when applied simultaneously in load combination #2.

## Code References

When calculating deflection from wind, the design wind load is determined by multiplying the Components & Cladding pressure by 0.7 (IBC 06 Table 1604.3, footnote f & IRC 06 Table R301.7, footnote a).



Deflection of individual wall studs is calculated similar to that of joists and beams. The stud height, on-center spacing and stiffness determine the deflection from a design wind load. Below are the building code deflection limit provisions dependent upon the wall coverings.

Wall Type or Component	Max Deflection Limit	Corresponding Max Deflection for 20' wall height	Code Reference
Exterior Walls with plaster or stucco finish	L/360	0.67 in	IRC 06: Table R301.7
Exterior walls with brittle finishes (brick and stone veneer - see note below)	L/240	1.0 in	IBC 06: Table 1604.3 IRC 06: Table R301.7
Interior walls and partitions	L/130	1.33 in	IRC 06: Table R301.7
Mullions (members supporting windows or doors)	L/175	—	IRC 06: R613.9.3
Exterior walls with flexible finishes (lap, panel and metal sidings)	L/120	2.0 in	IBC 06: Table 1604.3 IRC 06: Table R301.7

Wall stud deflection may occur both into the structure (positive pressure) or out from the structure (negative pressure). Thus, the total amount of possible movement is actually almost twice the deflection value shown in the design tables (see detail below). As shown in the table above, using the code minimum L/120 limit for 20' stud height can result in a deflection of 2 inches. More restrictive deflection limits may be used, similar to Boise Cascade's Three and Four Star Floor Performance tables for BCI<sup>®</sup> Joists. The allowable load tables on pages 9-11 provide maximum loads for deflection limits ranging from L/360 to L/120. For applications where a tighter deflection limit is needed, the stud may be designed using the BC COLUMN<sup>™</sup> software. As is the case with floors, the deflection of tall walls should be considered in the design phase of the project.

Deflection criteria is used to limit serviceability issues such as doors and windows binding, cracking of exterior and interior surface materials, perceived sounds due to wall movement, glass breaking, wall vibration and movement when pushed on. Wind produces pressure and suction loads on a wall producing deflection inward and outward. Vibration of walls can occur with high span/depth ratios much like a floor joist where depth equals the wall thickness. For further information on wall vibration, please contact Boise Cascade EWP Engineering.

In regards to brick veneer, though the IBC and IRC list a deflection limit of L/240, the Brick Industry Association (BIA), recommends designing studs to a deflection limit of L/600 to limit cracking of the veneer caused by excessive deflection. Such designs may be analyzed using BC COLUMN<sup>™</sup> software.

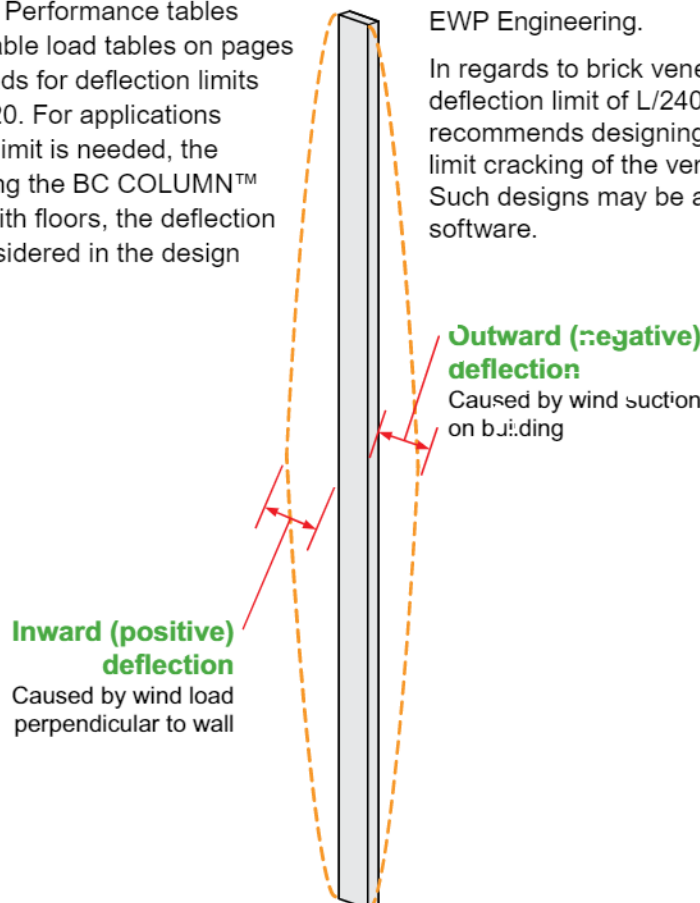

# Determining Wind Load

In some areas the design wind load, in units of psf [lb/ft<sup>2</sup>], is provided for residential construction by the local building code jurisdiction. For example, the State of Oregon Residential Code lists design wind loads for each county, ranging from 15 to 23 psf. *Please refer to the local building code department for such information.*

For areas that do not provide a wind load or for non-residential projects, the wind load may be determined by using the basic wind speed, in units of mph or miles per hour. The wind speed is then converted into a design wind load by calculating all the necessary factors required by ASCE 7, per the IRC and IBC codes. These factors are dependent on the site location of the project and the dimensions of the structure. Typically, the project's design professional of record performs this analysis. The following is an overview of this procedure:

- Determine basic wind speed:** Contour maps are provided in the IRC & IBC. The majority of the inland U.S. has a wind speed of 90 mph. However, basic wind speeds up to 150 mph are required in coastal areas. In addition, special wind region areas exist where the wind speed is higher. Consult with the local building code jurisdiction for the site's design wind speed.
- Determine the project's exposure category:** The exposure of the site will affect the wind load, wind pressure will be less within a subdivision versus a structure near a body of water. For wood-frame buildings, the three exposure categories are defined (see IRC 301.2.1.4 for complete definitions):
  - Exposure B: Urban and suburban (subdivision) areas, more inland.
  - Exposure C: Open terrain with scattered obstructions less than 30 feet tall extending more than 1500 feet from the site in any direction.
  - Exposure D: Flat, unobstructed areas exposed to wind over open water (excluding shorelines in hurricane prone regions) for a distance of at least 1 mile.
- Determine the stud or column's effective wind area:** Calculated using the greater of  $L/3$  or the tributary area, see Effective Wind Area in Wind Load Definitions, page 7.
- Determine remaining factors:**
  - Importance Factor: 1.0 for most structures, 1.15 for essential service buildings.
  - Topographical Factor: 1.0 for most structures, higher for buildings on hills or ridges.
- Determine mean roof height:** The distance between grade and a midpoint height between the eave and ridge.
- Go to the tables in ASCE 7 to determine the design wind load.** For a mean roof height of 33', importance factor = 1.0 and topographical factor = 1.0, the following table may be used:

Exposure Category	Effective Wind Area	Wind Design Load [psf]															
		85 mph		90 mph		100 mph		110 mph		120 mph		130 mph		140 mph		150 mph	
		Interior Zone	End Zone	Interior Zone	End Zone	Interior Zone	End Zone	Interior Zone	End Zone	Interior Zone	End Zone	Interior Zone	End Zone	Interior Zone	End Zone	Interior Zone	End Zone
B	<=10	14.5	17.9	16.2	20.1	20.1	24.8	24.3	30.0	28.9	35.6	33.9	41.8	39.3	48.5	45.1	55.7
	20	13.9	16.7	15.6	18.7	19.2	23.1	23.3	27.9	27.7	33.2	32.5	39.0	37.7	45.2	43.2	51.9
	50	13.1	15.1	14.7	12.9	12.1	20.9	21.6	25.3	25.1	30.1	30.6	35.3	35.5	40.9	40.8	47.0
	>=100	12.5	13.9	14.0	15.6	17.3	19.2	20.9	23.3	24.9	27.7	29.2	32.5	33.9	37.7	38.9	43.2
C	<=10	20.2	24.9	22.6	27.9	27.9	34.5	33.8	41.7	40.2	49.6	47.2	58.2	54.7	67.5	62.8	77.5
	20	19.3	23.2	21.7	26.0	26.8	32.1	32.4	38.9	38.5	46.3	45.2	54.3	52.4	63.0	60.2	72.3
	50	18.2	21.0	20.4	23.6	25.2	29.1	30.5	35.2	36.3	41.9	42.6	49.1	49.4	57.0	56.8	65.4
	>=100	17.4	19.3	19.5	21.7	24.1	26.8	29.1	32.4	34.6	38.5	40.7	45.2	47.2	52.4	54.1	60.2
D	<=10	23.8	29.4	26.7	32.9	32.9	40.6	39.8	49.2	47.4	58.5	55.6	68.7	64.5	79.6	74.1	91.4
	20	22.8	27.4	25.6	30.7	31.6	37.9	38.2	45.8	45.4	54.6	53.3	64.0	61.8	74.3	71.0	85.3
	50	21.5	24.8	24.1	27.8	29.7	34.3	36.0	41.5	42.8	49.4	50.3	57.9	58.3	67.2	66.9	77.1
	>=100	20.5	22.8	23.0	25.6	28.4	31.5	34.3	38.2	40.9	45.4	48.0	53.3	55.6	61.3	63.8	71.0

- The values shown are based upon the ASCE 7-05 Analytical Procedure, Components & Cladding, Method 2. The corner end zone width of a wall is the smaller of 0.1 x wall length or 0.4 x wall height, but not less than 0.04 x wall length or 3'-0".
- For a mean roof height of 30 feet or less, the stated psf loads in the table above may be reduced 2.5 percent to reflect the values shown in the IRC code.

**ASCE 7:** A design standard published by the American Society of Civil Engineers (ASCE) that is referenced by the International Building Code (IBC). ASCE 7 – Minimum Design Loads for Buildings and Other Structures establishes the live, snow, seismic and wind loads for the building code.

**Components and Cladding (CC):** Structural components that do not qualify on their own as a MWFRS (see below). An individual wall stud is an example of a CC element.

**Effective Wind Area:** A factor used to calculate the wind load on a stud or column. The effective wind area is the greater value of the following two equations:

1. the square of the stud height divided by 3 or  $L^2/3$  (see adjacent value table) or
2. the stud height multiplied by the tributary width (or o.c. spacing for studs).

Effective Wind Area	
Wall Height [ft]	Stud/Column Effective Wind Area [ft <sup>2</sup> ]
≥ 18	100
16	35
14	65
12	42
10	33
8	21

**Exposure Category:** A factor used to calculate the design wind load (pressure) that accounts for the type of terrain surrounding the structure in question. The wind pressure will be less within a housing development versus a structure near a body of water. The following is summary of the exposure categories:

- B = Urban and suburban (subdivision) areas, forest land
- C = Open land with scattered obstructions of heights less than 30 feet
- D = Flat unobstructed areas and water surfaces

**In-Plane Loading:** Lateral loads applied along the length of the wall are referred to as in-plane loading (see detail below). Wind loading applied parallel to the wall length must be determined by the design professional of record. Bracing, braced wall panels and tie-down anchors at corners shall be determined by design professional of record and be in accordance with applicable building code

**Main Wind Force-Resisting System (MWFRS):** A classification of structural components. MWFRS generally refers to a system of elements that receives wind loading from more than one surface of the structure. An example of a MWFRS is an exterior wood shear wall. The shear wall receives seismic and wind load along its length (in-plane loading) and wind load perpendicular to its surface (out-of-plane loading).

**Out-of-Plane Loading:** Wind loading perpendicular to the wall length (see detail below). Tables shown in this guide are based on out-of-plane loading only.

**Wind Speed:** The value established by the building code or local building department which is then used, along with other factors, to determine the wind load. Wind Speed in ASCE 7 is now based upon a 3 second gust, determined by meteorological data and statistical analysis. Wind speed is provided in units of miles per hour (mph).

**Wind Load:** The design load used to size a stud or column. The wind load is determined by taking the wind speed and applying all the necessary factors per ASCE 7, including the geometry of the structure, exposure, etc. In some areas, the design wind load is provided for residential construction by the building code jurisdiction. Wind load is in units of pounds per square foot (psf).

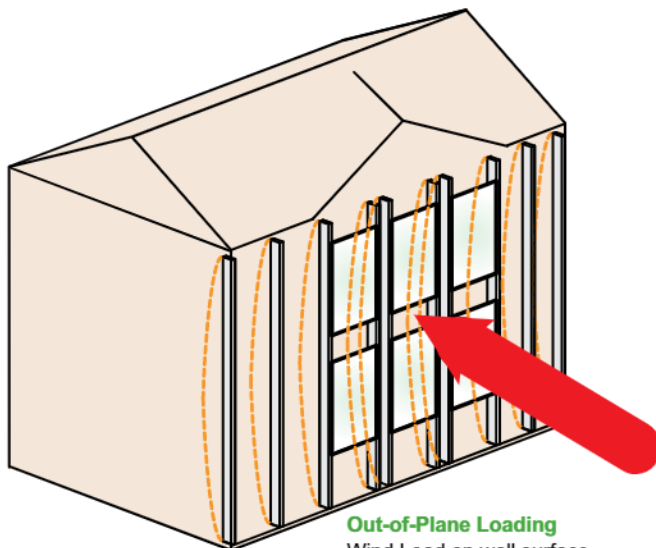

**Out-of-Plane Loading**  
Wind Load on wall surface  
Stress and deflection of studs caused by perpendicular loading

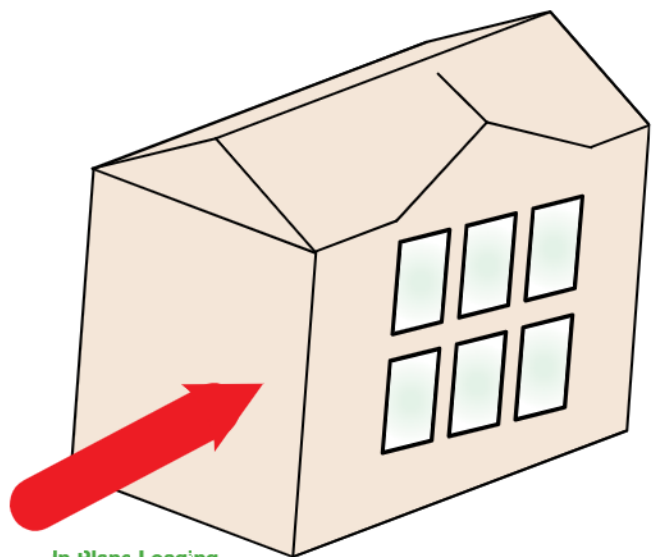

**In-Plane Loading**  
Racking of wall caused by wind and/or seismic loading on opposite wall, applying parallel force on window wall.

## VERSA-STUD® Design

**Given: Wall as shown**

**Wall Height:** 16'-0"

**Preliminary Stud Spacing:** 16" o.c.

**Roof Load:** 40 psf snow load, 15 psf dead load. BCI® rafter framing with an 18'-0" horizontal span and 2'-0" overhang

**Wind Load:** 20 psf load per local building department (see wind load section for more information on determining wind loading)

**Deflection Limit:** Possible brittle finish = L/240 (IRC Table R301.7)

### Solution:

#### Stud Design

Determine Vertical Load

$$\text{Roof Tributary Width} = [18'-0" / 2] + 2'-0" = 11'-0"$$

$$\text{Snow Load [plf]} = 40 \text{ lb/ft}^2 \times 11 \text{ ft} = 440 \text{ lb/ft}$$

$$\text{Snow Load [lb]} = 440 \text{ lb/ft} \times [16 \text{ in} / 12] = 587 \text{ lb}$$

$$\text{Dead Load [plf]} = 15 \text{ lb/ft}^2 \times 11 \text{ ft} = 165 \text{ lb/ft}$$

$$\text{Wall Weight [lb]} = 10 \text{ lb/ft}^2 \times 16 \text{ ft} \times [16 \text{ in} / 12] = 213 \text{ lb}$$

(assume wall self-weight of 10 psf)

$$\text{Dead Load [lb]} = 165 \text{ lb/ft} \times [16 \text{ in} / 12] = 220 \text{ lb}$$

$$\text{Total Load [lb]} = 587 \text{ lb} + 220 \text{ lb} + 213 \text{ lb} = 1020 \text{ lb}$$

Go to **VERSA STUD® 1.7 100 1½" x 5½" load charts**, page 10

L/240, 16 ft wall height

Max. Loading, Single Stud,  
Vertical Load = 3490 lb > 1020 lb **OK!**

20 PSF Wind Load, Max. Stud Spacing = 16" **OK!**

**VERSA-STUD® 1.7 2400 1½" x 5½" @ 16" o.c. OK!**

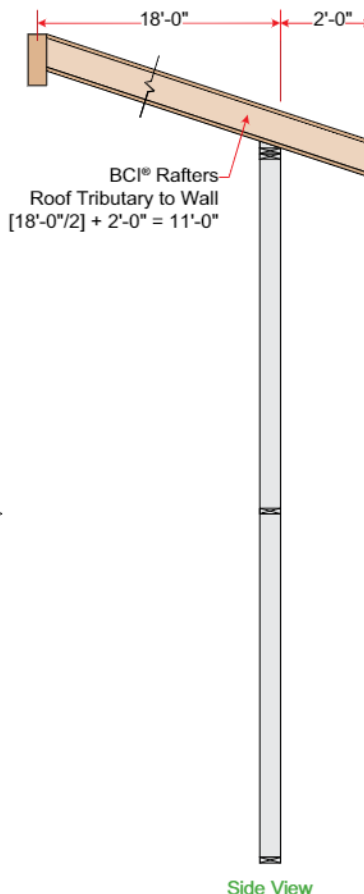
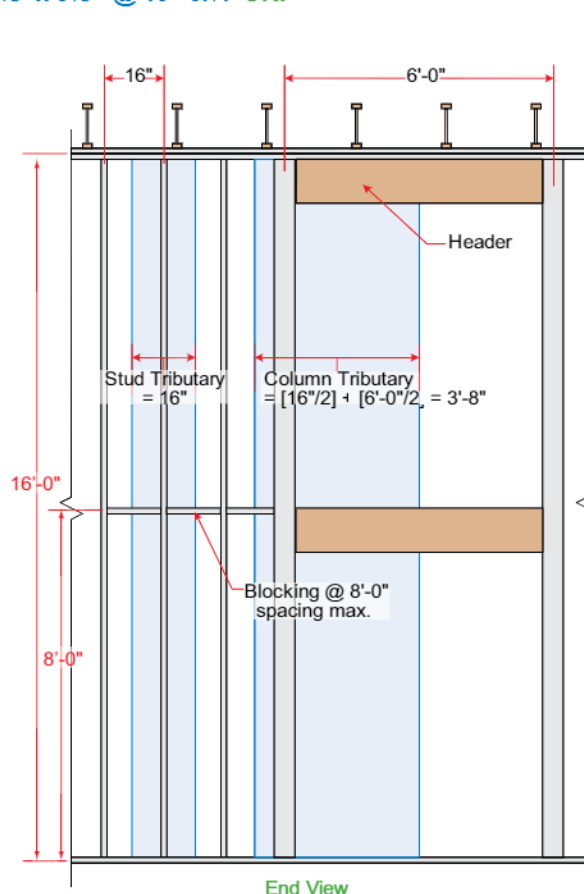

## VERSA-LAM® Column Design

**Determine Vertical Load**

$$\text{Column Tributary Width} = [6'-0" / 2] + [16 \text{ in} / 2] = 3'-8"$$

$$\text{Snow Load [lb]} = 440 \text{ lb/ft} \times 3'-8" = 1615 \text{ lb}$$

$$\text{Dead Load [lb]} = 165 \text{ lb/ft} \times 3'-8" = 606 \text{ lb}$$

$$\text{Total Load [lb]} = 1615 \text{ lb} + 606 \text{ lb} = 2221 \text{ lb}$$

$$\text{Wind Load [plf]} = 20 \text{ lb/ft}^2 \times 3'-8" = 73.4 \text{ lb/ft}$$

Go to **VERSA-LAM® 1.7 250 Exterior Wall Column Table**, page 13

L/240, 16 ft wall height

#### 3½" x 5¼" Column

$$\text{Vertical Load} = 7358 \text{ lb} > 2221 \text{ lb} \text{ OK!}$$

$$\text{Wind Load} = 55.6 \text{ lb/ft} < 73.4 \text{ lb/ft} \text{ NOT OK}$$

#### 5¼" x 5¼" Column

$$\text{Vertical Load} = 10680 \text{ lb} > 2221 \text{ lb} \text{ OK!}$$

$$\text{Wind Load} = 83.4 \text{ lb/ft} > 73.4 \text{ lb/ft} \text{ OK!}$$

**VERSA-LAM® 1.7 2650 Column: 5¼" x 5¼" OK!**



## VERSA-STUD® 1.7 2400 1½" x 3½"

Deflection Limit	Wall Height [ft]	MAXIMUM LOADING				10 PSF WIND LOAD SPACING & TRIBUTARY			15 PSF WIND LOAD SPACING & TRIBUTARY			20 PSF WIND LOAD SPACING & TRIBUTARY		
		Single Stud		Double Stud		Single Stud		Double Stud	Single Stud		Double Stud	Single Stud		Double Stud
		Vertical Load [lb]	Wind Load [lb/ft]	Vertical Load [lb]	Wind Load [lb/ft]	Max Stud Spacing [in]	Max Tributary Width [in]	Max Tributary Width [in]	Max Stud Spacing [in]	Max Tributary Width [in]	Max Tributary Width [in]	Max Stud Spacing [in]	Max Tributary Width [in]	Max Tributary Width [in]
L/360	8	2953	37.7	4219	75.3	24	15.2	90.4	24	30.1	61.3	19.2	22.6	45.2
	9	2953	26.5	4182	52.9	24	13.7	63.5	24	21.2	42.3	12	15.9	31.7
	10	2615	19.3	4094	38.6	19.2	23.1	46.3	12	15.4	30.9	8	11.6	23.1
	11	2211	14.5	3943	29.0	16	17.4	34.8	8	11.6	23.2	8	8.7	17.4
	12	1894	11.2	3720	22.3	12	13.4	26.3	6	8.9	17.9	6	6.7	13.4
	13	1641	8.8	3248	17.6	8	10.7	21.1	6	7.1	14.0	6	5.3	10.5
14	1435	7.0	2843	14.1	8	8.4	16.9	4	5.6	11.2	6	4.2	8.4	
L/240	8	2953	56.5	3785	113.0	24	67.6	135.6	24	75.2	150.4	24	33.9	67.8
	9	2762	39.7	3764	79.4	24	47.6	95.2	24	31.7	63.5	19.2	23.8	47.6
	10	2329	28.9	3687	57.8	24	34.7	69.4	19.2	21.1	46.3	16	17.4	34.7
	11	1988	21.7	3549	43.5	24	26.1	52.2	16	17.4	34.8	12	13.0	26.1
	12	1716	16.7	3357	33.5	19.2	20.1	41.2	12	13.4	26.8	8	11.0	21.1
	13	1496	13.2	2951	26.3	12	15.8	31.6	8	10.5	21.1	6	7.9	15.8
14	1317	10.5	2598	21.1	12	12.6	25.3	8	8.4	16.9	6	6.3	12.6	
L/180	8	2861	75.3	3352	150.6	24	90.4	180.3	24	61.3	120.5	24	45.2	90.4
	9	2426	52.9	3361	105.8	24	63.5	127.0	24	42.3	84.6	24	31.7	63.5
	10	2075	38.6	3306	77.1	24	46.3	92.6	24	31.9	61.7	19.2	23.1	46.3
	11	1791	29.0	3195	57.9	24	34.8	69.5	19.2	23.2	46.4	16	17.4	34.8
	12	1560	22.3	3036	44.6	24	26.3	53.6	16	17.9	35.7	12	13.4	26.3
	13	1370	17.6	2689	35.1	19.2	21.1	42.1	12	14.0	28.1	8	11.5	21.1
14	1212	14.1	2381	28.1	16	16.9	33.7	8	11.2	22.5	8	8.4	16.9	
L/120	8	2002	113.0	2443	226.0	24	135.6	271.2	24	91.1	181.8	24	67.8	135.6
	9	1809	79.4	2558	158.7	24	95.2	190.4	24	63.5	127.0	24	47.6	95.2
	10	1614	57.8	2584	115.7	24	69.4	138.8	24	46.3	92.6	24	34.7	69.4
	11	1436	43.5	2546	86.9	24	52.2	104.3	24	34.8	69.5	24	26.1	52.2
	12	1280	33.5	2460	67.0	24	40.2	81.3	24	26.3	53.6	19.2	23.1	40.2
	13	1144	26.3	2220	52.7	24	31.6	63.2	19.2	21.1	42.1	12	15.8	31.6
14	1027	21.1	1998	42.2	24	25.3	51.6	16	16.9	33.7	12	12.6	25.3	

Deflection Limit	Wall Height [ft]	MAXIMUM LOADING				25 PSF WIND LOAD SPACING & TRIBUTARY			30 PSF WIND LOAD SPACING & TRIBUTARY			40 PSF WIND LOAD SPACING & TRIBUTARY		
		Single Stud		Double Stud		Single Stud		Double Stud	Single Stud		Double Stud	Single Stud		Double Stud
		Vertical Load [lb]	Wind Load [lb/ft]	Vertical Load [lb]	Wind Load [lb/ft]	Max Stud Spacing [in]	Max Tributary Width [in]	Max Tributary Width [in]	Max Stud Spacing [in]	Max Tributary Width [in]	Max Tributary Width [in]	Max Stud Spacing [in]	Max Tributary Width [in]	Max Tributary Width [in]
L/360	8	2953	37.7	4219	75.3	16	18.1	36.2	12	15.1	30.1	8	11.3	22.6
	9	2953	26.5	4182	52.9	12	12.7	25.4	8	10.6	21.2	6	7.9	15.9
	10	2615	19.3	4094	38.6	8	9.3	18.5	6	7.7	15.4	4	5.8	11.6
	11	2211	14.5	3943	29.0	6	7.0	13.9	4	5.8	11.6	4	4.3	8.7
	12	1894	11.2	3720	22.3	4	5.4	10.7	4	4.5	8.9	4	3.3	6.7
	13	1641	8.8	3248	17.6	4	4.2	8.4	4	3.5	7.0	4	2.6	5.3
14	1435	7.0	2843	14.1	4	3.4	6.7	4	2.8	5.6	4	2.1	4.2	
L/240	8	2953	56.5	3785	113.0	24	27.1	54.2	19.2	22.6	45.2	16	16.9	33.9
	9	2762	39.7	3764	79.4	16	19.0	38.1	12	15.9	31.7	8	11.9	23.8
	10	2329	28.9	3687	57.8	12	13.9	27.8	8	11.6	23.1	8	8.7	17.4
	11	1988	21.7	3549	43.5	8	10.4	20.9	8	8.7	17.4	6	6.5	13.0
	12	1716	16.7	3357	33.5	8	8.0	16.1	6	6.7	13.4	4	5.0	10.0
	13	1496	13.2	2951	26.3	6	6.3	12.6	4	5.3	10.5	4	3.9	7.9
14	1317	10.5	2598	21.1	4	5.1	10.1	4	4.2	8.4	4	3.2	6.3	
L/180	8	2861	75.3	3352	150.6	24	36.2	72.3	24	30.1	60.3	19.2	22.6	45.2
	9	2426	52.9	3361	105.8	24	25.4	50.8	19.2	21.2	42.3	12	15.9	31.7
	10	2075	38.6	3306	77.1	16	18.5	37.0	12	15.4	30.9	8	11.6	23.1
	11	1791	29.0	3195	57.9	12	13.9	27.8	8	11.6	23.2	8	8.7	17.4
	12	1560	22.3	3036	44.6	8	10.7	21.4	8	8.9	17.9	6	6.7	13.4
	13	1370	17.6	2689	35.1	8	8.4	16.9	6	7.0	14.0	4	5.3	10.5
14	1212	14.1	2381	28.1	6	6.7	13.5	4	5.6	11.2	4	4.2	8.4	
L/120	8	2002	113.0	2443	226.0	24	54.2	108.5	24	45.2	90.4	24	33.9	67.8
	9	1809	79.4	2558	158.7	24	38.1	76.2	24	31.7	63.5	19.2	23.8	47.6
	10	1614	57.8	2584	115.7	24	27.8	55.5	19.2	23.1	46.3	16	17.4	34.7
	11	1436	43.5	2546	86.9	19.2	20.9	41.7	16	17.4	34.8	12	13.0	26.1
	12	1280	33.5	2460	67.0	16	16.1	32.1	12	13.4	26.8	8	10.0	20.1
	13	1144	26.3	2220	52.7	12	12.6	25.3	8	10.5	21.1	6	7.9	15.8
14	1027	21.1	1998	42.2	8	10.1	20.2	8	8.4	16.9	6	6.3	12.6	

**Notes**

- Wall stud analysis per 2005 National Design Specification (NDS) for Wood Construction.
- For 3-ply and 4-ply built up columns, multiply double stud table values by 1.5 and 2.0
- Stud depth blocking required at a maximum spacing of 8'-0" for single studs
- Structural sheathing or structural siding installed on one side of wall.

- Double stud values assume unsupported lateral length of 7'-0".
- Table assumes wind load duration factor of 1.0 and vertical load duration factor of 1.0.
- Table assumes compression perpendicular to grain for plate of 450 psi.
- Vertical dead load may not exceed 50% of the total vertical load.
- Repetitive member increase for bending (1.04) applied to single studs only.
- Compression perpendicular to grain stress adjusted per NDS 3.10.4 for single studs only.

## VERSA-STUD® 1.7 2400 1½" x 5½"

Deflection Limit	Wall Height [ft]	MAXIMUM LOADING				10 PSF WIND LOAD SPACING & TRIBUTARY			15 PSF WIND LOAD SPACING & TRIBUTARY			20 PSF WIND LOAD SPACING & TRIBUTARY		
		Single Stud		Double Stud		Single Stud		Double Stud	Single Stud		Double Stud	Single Stud		Double Stud
		Vertical Load [lb]	Wind Load [lb/ft]	Vertical Load [lb]	Wind Load [lb/ft]	Max Stud Spacing [in]	Max Tributary Width [in]	Max Tributary Width [in]	Max Stud Spacing [in]	Max Tributary Width [in]	Max Tributary Width [in]	Max Stud Spacing [in]	Max Tributary Width [in]	Max Tributary Width [in]
L/360	10	4641	74.8	6469	149.6	24	89.8	179.6	24	59.9	119.7	24	44.9	89.8
	12	4641	43.3	6542	86.6	24	52.0	103.9	24	34.6	69.3	24	26.0	52.0
	14	4641	27.3	6495	54.5	24	32.7	65.4	19.2	21.8	43.6	16	16.4	32.7
	16	3933	18.3	6313	36.5	19.2	21.9	43.8	12	14.6	29.2	8	11.0	21.9
	17	3537	15.2	6163	30.5	16	18.3	36.6	12	12.2	24.4	8	9.1	18.3
	18	3198	12.8	5969	25.7	12	15.4	30.8	8	10.3	20.5	6	7.7	15.4
	19	2906	10.9	5732	21.8	12	13.1	26.2	8	8.7	17.5	6	6.5	13.1
20	2651	9.4	5234	18.7	8	11.2	22.4	6	7.5	15.0	4	5.6	11.2	
L/240	10	4641	112.2	5638	224.5	24	134.7	269.4	24	89.8	179.6	24	67.3	134.7
	12	4641	65.0	5804	129.9	24	77.9	155.9	24	52.0	103.9	24	39.0	77.9
	14	4324	40.9	5800	81.8	24	49.1	98.2	24	32.7	65.4	24	24.5	49.1
	16	3490	27.4	5645	54.8	24	32.9	65.8	19.2	21.9	43.8	16	16.4	32.9
	17	3160	22.8	5512	45.7	24	27.4	54.8	16	18.3	36.6	12	13.7	27.4
	18	2873	19.2	5345	38.5	19.2	23.1	46.2	12	15.4	30.8	8	11.5	23.1
	19	2624	16.4	5142	32.7	19.2	19.6	39.3	12	13.1	26.2	8	9.8	19.6
20	2405	14.0	4721	28.1	16	16.8	33.7	8	11.2	22.4	8	8.4	16.8	
L/180	10	4641	149.6	4744	299.3	24	179.6	359.2	24	119.7	239.4	24	89.8	179.6
	12	4620	86.6	5049	173.2	24	103.9	207.8	24	69.3	138.6	24	52.0	103.9
	14	3759	54.5	5122	109.1	24	65.4	130.9	24	43.6	87.3	24	32.7	65.4
	16	3097	36.5	5025	73.1	24	43.8	87.7	24	29.2	58.5	19.2	21.9	43.8
	17	2825	30.5	4921	60.9	24	36.6	73.1	24	24.4	48.7	16	18.3	36.6
	18	2586	25.7	4786	51.3	24	30.8	61.6	19.2	20.5	41.1	12	15.4	30.8
	19	2374	21.8	4624	43.6	24	26.2	52.4	16	17.5	34.9	12	13.1	26.2
20	2187	18.7	4265	37.4	19.2	22.4	44.9	12	15.0	29.9	8	11.2	22.4	
L/120	10	3091	219.6	2758	422.3	24	263.5	506.7	24	179.6	359.2	24	134.7	269.4
	12	3006	129.9	3424	259.8	24	155.9	311.8	24	103.9	207.8	24	77.9	155.9
	14	2721	81.8	3760	163.6	24	98.2	196.3	24	65.4	130.9	24	49.1	98.2
	16	2380	54.8	3849	109.6	24	65.8	131.5	24	43.8	87.7	24	32.9	65.8
	17	2219	45.7	3826	91.4	24	54.8	109.7	24	36.6	73.1	24	27.4	54.8
	18	2066	38.5	3770	77.0	24	46.2	92.4	24	30.8	61.6	19.2	23.1	46.2
	19	1927	32.7	3684	65.5	24	39.3	78.5	24	26.2	52.4	19.2	19.6	39.3
20	1798	28.1	3452	56.1	24	33.7	67.3	19.2	22.4	44.9	16	16.8	33.7	

Deflection Limit	Wall Height [ft]	MAXIMUM LOADING				25 PSF WIND LOAD SPACING & TRIBUTARY			30 PSF WIND LOAD SPACING & TRIBUTARY			40 PSF WIND LOAD SPACING & TRIBUTARY		
		Single Stud		Double Stud		Single Stud		Double Stud	Single Stud		Double Stud	Single Stud		Double Stud
		Vertical Load [lb]	Wind Load [lb/ft]	Vertical Load [lb]	Wind Load [lb/ft]	Max Stud Spacing [in]	Max Tributary Width [in]	Max Tributary Width [in]	Max Stud Spacing [in]	Max Tributary Width [in]	Max Tributary Width [in]	Max Stud Spacing [in]	Max Tributary Width [in]	Max Tributary Width [in]
L/360	10	4641	74.8	6469	149.6	24	35.9	71.8	24	29.9	59.9	19.2	22.4	44.9
	12	4641	43.3	6542	86.6	19.2	20.8	41.6	16	17.3	34.6	12	13.0	26.0
	14	4641	27.3	6495	54.5	12	13.1	26.2	8	10.9	21.8	8	8.2	16.4
	16	3933	18.3	6313	36.5	8	8.8	17.5	6	7.3	14.6	4	5.5	11.0
	17	3537	15.2	6163	30.5	6	7.3	14.6	6	6.1	12.2	4	4.6	9.1
	18	3198	12.8	5969	25.7	6	6.2	12.3	4	5.1	10.3	--	3.8	7.7
	19	2906	10.9	5732	21.8	4	5.2	10.5	4	4.4	8.7	--	3.3	6.5
20	2651	9.4	5234	18.7	4	4.5	9.0	--	3.7	7.5	--	2.8	5.6	
L/240	10	4641	112.2	5638	224.5	24	53.9	107.7	24	44.9	89.8	24	33.7	67.3
	12	4641	65.0	5804	129.9	24	31.2	62.4	24	26.0	52.0	19.2	19.5	39.0
	14	4324	40.9	5800	81.8	19.2	19.6	39.3	16	16.4	32.7	12	12.3	24.5
	16	3490	27.4	5645	54.8	12	13.2	26.3	8	11.0	21.9	8	8.2	16.4
	17	3160	22.8	5512	45.7	8	11.0	21.9	8	9.1	18.3	6	6.9	13.7
	18	2873	19.2	5345	38.5	8	9.2	18.5	6	7.7	15.4	4	5.8	11.5
	19	2624	16.4	5142	32.7	6	7.9	15.7	6	6.5	13.1	4	4.9	9.8
20	2405	14.0	4721	28.1	6	6.7	13.5	4	5.6	11.2	4	4.2	8.4	
L/180	10	4641	149.6	4744	299.3	24	71.8	143.7	24	59.9	119.7	24	44.9	89.8
	12	4620	86.6	5049	173.2	24	41.6	83.1	24	34.6	69.3	24	26.0	52.0
	14	3759	54.5	5122	109.1	24	26.2	52.4	19.2	21.8	43.6	16	16.4	32.7
	16	3097	36.5	5025	73.1	16	17.5	35.1	12	14.6	29.2	8	11.0	21.9
	17	2825	30.5	4921	60.9	12	14.6	29.2	12	12.2	24.4	8	9.1	18.3
	18	2586	25.7	4786	51.3	12	12.3	24.6	8	10.3	20.5	6	7.7	15.4
	19	2374	21.8	4624	43.6	8	10.5	20.9	8	8.7	17.5	6	6.5	13.1
20	2187	18.7	4265	37.4	8	9.0	18.0	6	7.5	15.0	4	5.6	11.2	
L/120	10	3091	219.6	2758	422.3	24	107.7	215.5	24	89.8	179.6	24	65.9	126.7
	12	3006	129.9	3424	259.8	24	62.4	124.7	24	52.0	103.9	24	39.0	77.9
	14	2721	81.8	3760	163.6	24	39.3	78.5	24	32.7	65.4	24	24.5	49.1
	16	2380	54.8	3849	109.6	24	26.3	52.6	19.2	21.9	43.8	16	16.4	32.9
	17	2219	45.7	3826	91.4	19.2	21.9	43.9	16	18.3	36.6	12	13.7	27.4
	18	2066	38.5	3770	77.0	16	18.5	37.0	12	15.4	30.8	8	11.5	23.1
	19	1927	32.7	3684	65.5	12	15.7	31.4	12	13.1	26.2	8	9.8	19.6
20	1798	28.1	3452	56.1	12	13.5	26.9	8	11.2	22.4	8	8.4	16.8	

**Notes**

- Wall stud analysis per 2005 National Design Specification (NDS) for Wood Construction.
- For 3-ply and 4-ply built up columns, multiply double stud table values by 1.5 and 2.0.
- Full depth blocking required at a maximum spacing of 8'-0" for single studs.
- Structural sheathing or structural siding installed on one side of wall.

- Double stud values assume unsupported lateral length of 7'-0".
- Table assumes wind load duration factor of 1.6 and vertical load duration factor of 1.0.
- Table assumes compression perpendicular to grain for plate of 450 psi.
- Vertical dead load may not exceed 50% of the total vertical load.
- Repetitive member increase for bending (1.04) applied to single studs only.
- Compression perpendicular to grain stress adjusted per NDS 3.10.4 for single studs only.

## VERSA-STUD® 1.7 2400 1½" x 7¼"

Deflection Limit	Wall Height [ft]	MAXIMUM LOADING				10 PSF WIND LOAD SPACING & TRIBUTARY			15 PSF WIND LOAD SPACING & TRIBUTARY			20 PSF WIND LOAD SPACING & TRIBUTARY		
		Single Stud		Double Stud		Single Stud		Double Stud	Single Stud		Double Stud	Single Stud		Double Stud
		Vertical Load [lb]	Wind Load [lb/ft]	Vertical Load [lb]	Wind Load [lb/ft]	Max Stud Spacing [in]	Max Tributary Width [in]	Max Tributary Width [in]	Max Stud Spacing [in]	Max Tributary Width [in]	Max Tributary Width [in]	Max Stud Spacing [in]	Max Tributary Width [in]	Max Tributary Width [in]
L/360	10	6117	171.4	8003	342.8	24	205.7	411.3	24	137.1	274.2	24	102.8	205.7
	12	6117	99.2	8319	198.4	24	119.0	238.0	24	79.3	158.7	24	59.5	119.0
	14	6117	62.5	8479	124.9	24	74.9	149.9	24	50.0	99.9	24	37.5	74.9
	16	6117	41.8	8536	83.7	24	50.2	100.4	24	33.5	66.9	24	25.1	50.2
	18	6117	29.4	8496	58.8	24	35.3	70.5	19.2	23.5	47.0	16	17.6	35.3
	20	5638	21.4	8357	42.8	24	25.7	51.4	16	17.1	34.3	12	12.9	25.7
	22	4781	16.1	8108	32.2	19.2	19.3	38.6	12	12.9	25.8	8	9.7	19.3
24	4104	12.4	7726	24.8	12	14.9	29.8	8	9.9	19.8	6	7.4	14.9	
L/240	10	6117	257.1	6488	514.2	24	308.5	617.0	24	205.7	411.3	24	154.2	308.5
	12	6117	148.8	7064	297.5	24	178.5	357.1	24	119.0	238.0	24	89.3	178.5
	14	6117	93.7	7379	187.4	24	112.4	224.8	24	74.9	149.9	24	56.2	112.4
	16	6117	62.8	7522	125.5	24	75.3	150.6	24	50.2	100.4	24	37.7	75.3
	18	5850	44.1	7534	88.2	24	52.9	105.8	24	35.3	70.5	24	26.4	52.9
	20	4957	32.1	7429	64.3	24	38.6	77.1	24	25.7	51.4	19.2	19.3	38.6
	22	4249	24.1	7210	48.3	24	29.0	57.9	19.2	19.3	38.6	12	14.5	29.0
24	3679	18.6	6889	37.2	19.2	22.3	44.6	12	14.9	29.8	8	11.2	22.3	
L/180	10	6117	342.8	4649	685.5	24	411.3	822.6	24	274.2	548.4	24	205.7	411.3
	12	6117	198.4	5673	396.7	24	238.0	476.1	24	158.7	317.4	24	119.0	238.0
	14	6117	124.9	6206	249.8	24	149.9	299.8	24	99.9	199.9	24	74.9	149.9
	16	5872	83.7	6478	167.4	24	100.4	200.8	24	66.9	133.9	24	50.2	100.4
	18	5037	58.8	6586	117.5	24	70.5	141.1	24	47.0	94.0	24	35.3	70.5
	20	4346	42.8	6548	85.7	24	51.4	102.8	24	34.3	68.6	24	25.7	51.4
	22	3774	32.2	6393	64.4	24	38.6	77.3	24	25.8	51.5	19.2	19.3	38.6
24	3304	24.8	6141	49.6	24	29.8	59.5	19.2	19.8	39.7	12	14.9	29.8	
L/120	10	6117	370.0	3940	711.5	24	444.0	853.9	24	296.0	569.2	24	222.0	426.9
	12	4895	256.9	3672	494.1	24	308.3	593.0	24	205.6	395.3	24	154.2	296.5
	14	3703	187.4	3447	363.0	24	224.8	435.6	24	149.9	290.4	24	112.4	217.8
	16	3746	125.5	4233	251.1	24	150.6	301.3	24	100.4	200.8	24	75.3	150.6
	18	3528	88.2	4645	176.3	24	105.8	211.6	24	70.5	141.1	24	52.9	105.8
	20	3223	64.3	4826	128.5	24	77.1	154.2	24	51.4	102.8	24	38.6	77.1
	22	2914	48.3	4862	96.6	24	57.9	115.9	24	38.6	77.3	24	29.0	57.9
24	2626	37.2	4774	74.4	24	44.6	89.3	24	29.8	59.5	19.2	22.3	44.6	

Deflection Limit	Wall Height [ft]	MAXIMUM LOADING				25 PSF WIND LOAD SPACING & TRIBUTARY			30 PSF WIND LOAD SPACING & TRIBUTARY			40 PSF WIND LOAD SPACING & TRIBUTARY		
		Single Stud		Double Stud		Single Stud		Double Stud	Single Stud		Double Stud	Single Stud		Double Stud
		Vertical Load [lb]	Wind Load [lb/ft]	Vertical Load [lb]	Wind Load [lb/ft]	Max Stud Spacing [in]	Max Tributary Width [in]	Max Tributary Width [in]	Max Stud Spacing [in]	Max Tributary Width [in]	Max Tributary Width [in]	Max Stud Spacing [in]	Max Tributary Width [in]	Max Tributary Width [in]
L/360	10	6117	171.4	8003	342.8	24	82.3	164.5	24	68.6	137.1	24	51.4	102.8
	12	6117	99.2	8319	198.4	24	47.6	95.2	24	39.7	79.3	24	29.8	59.5
	14	6117	62.5	8479	124.9	24	30.0	60.0	24	25.0	50.0	16	18.7	37.5
	16	6117	41.8	8536	83.7	19.2	20.1	40.2	16	16.7	33.5	12	12.6	25.1
	18	6117	29.4	8496	58.8	12	14.1	28.2	8	11.8	23.5	8	8.8	17.6
	20	5638	21.4	8357	42.8	8	10.3	20.6	8	8.6	17.1	6	6.4	12.9
	22	4781	16.1	8108	32.2	6	7.7	15.5	6	6.4	12.9	4	4.8	9.7
24	4104	12.4	7726	24.8	4	6.0	11.9	4	5.0	9.9	--	3.7	7.4	
L/240	10	6117	257.1	6488	514.2	24	123.4	246.8	24	102.8	205.7	24	77.1	154.2
	12	6117	148.8	7064	297.5	24	71.4	142.8	24	59.5	119.0	24	44.6	89.3
	14	6117	93.7	7379	187.4	24	45.0	89.9	24	37.5	74.9	24	28.1	56.2
	16	6117	62.8	7522	125.5	24	30.1	60.3	24	25.1	50.2	16	18.8	37.7
	18	5850	44.1	7534	88.2	19.2	21.2	42.3	16	17.6	35.3	12	13.2	26.4
	20	4957	32.1	7429	64.3	12	15.4	30.8	12	12.9	25.7	8	9.6	19.3
	22	4249	24.1	7210	48.3	8	11.6	23.2	8	9.7	19.3	6	7.2	14.5
24	3679	18.6	6889	37.2	8	8.9	17.9	6	7.4	14.9	4	5.6	11.2	
L/180	10	6117	342.8	4649	685.5	24	164.5	329.1	24	137.1	274.2	24	102.8	205.7
	12	6117	198.4	5673	396.7	24	95.2	190.4	24	79.3	158.7	24	59.5	119.0
	14	6117	124.9	6206	249.8	24	60.0	119.9	24	50.0	99.9	24	37.5	74.9
	16	5872	83.7	6478	167.4	24	40.2	80.3	24	33.5	66.9	24	25.1	50.2
	18	5037	58.8	6586	117.5	24	28.2	56.4	19.2	23.5	47.0	16	17.6	35.3
	20	4346	42.8	6548	85.7	19.2	20.6	41.1	16	17.1	34.3	12	12.9	25.7
	22	3774	32.2	6393	64.4	12	15.5	30.9	12	12.9	25.8	8	9.7	19.3
24	3304	24.8	6141	49.6	8	11.9	23.8	8	9.9	19.8	6	7.4	14.9	
L/120	10	6117	370.0	3940	711.5	24	177.6	341.5	24	148.0	284.6	24	111.0	213.5
	12	4895	256.9	3672	494.1	24	123.3	237.2	24	102.8	197.7	24	77.1	148.2
	14	3703	187.4	3447	363.0	24	89.9	174.3	24	74.9	145.2	24	56.2	108.9
	16	3746	125.5	4233	251.1	24	60.3	120.5	24	50.2	100.4	24	37.7	75.3
	18	3528	88.2	4645	176.3	24	42.3	84.6	24	35.3	70.5	24	26.4	52.9
	20	3223	64.3	4826	128.5	24	30.8	61.7	24	25.7	51.4	19.2	19.3	38.6
	22	2914	48.3	4862	96.6	19.2	23.2	46.4	19.2	19.3	38.6	12	14.5	29.0
24	2626	37.2	4774	74.4	16	17.9	35.7	12	14.9	29.8	8	11.2	22.3	

**Notes**

- Wall stud analysis per 2005 National Design Specification (NDS) for Wood Construction.
- For 3-ply and 4-ply built up columns, multiply double stud table values by 1.5 and 2.0.
- Full depth blocking required at a maximum spacing of 8'-0" for single studs.
- Structural sheathing or structural siding installed on one side of wall.
- Double stud values assume unsupported lateral length of 7'-0".
- Table assumes wind load duration factor of 1.6 and vertical load duration factor of 1.0.
- Table assumes compression perpendicular to grain for plate of 450 psi.
- Vertical dead load may not exceed 50% of the total vertical load.
- Repetitive member increase for bending (1.04) applied to single studs only.
- Compression perpendicular to grain stress adjusted per NDS 3.10.4 for single studs only.

**Multiple-Ply Stud Connections**

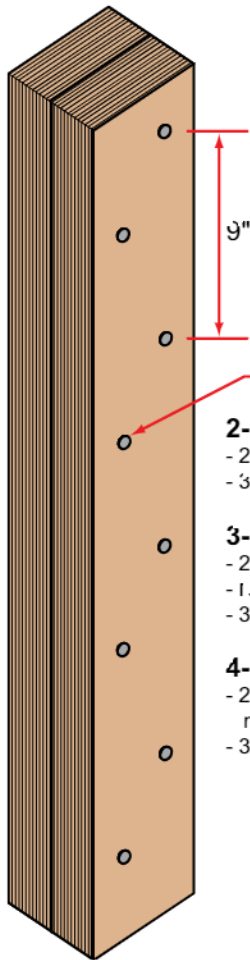

Stagger rows

**2-Ply 1½" Connection**  
 - 2 rows 10d (min) nails @ 9" o.c.  
 - 3 rows for 9¼" and greater studs

**3-Ply 1½" Connection**  
 - 2 rows 10d (min) nails @ 9" o.c.  
 - Nail from each side  
 - 3 rows for 9¼" and greater studs

**4-Ply 1½" Connection**  
 - 2 rows 10d (min) nails @ 9" o.c.,  
 nailed from each ply to each ply  
 - 3 rows for 9¼" and greater studs

**Header to Column**

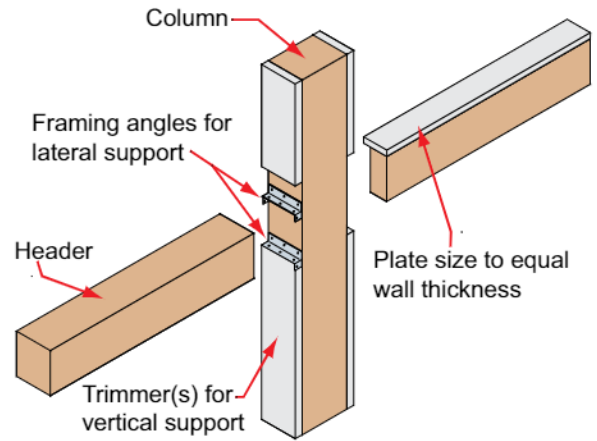

**Column to Bottom Plate**

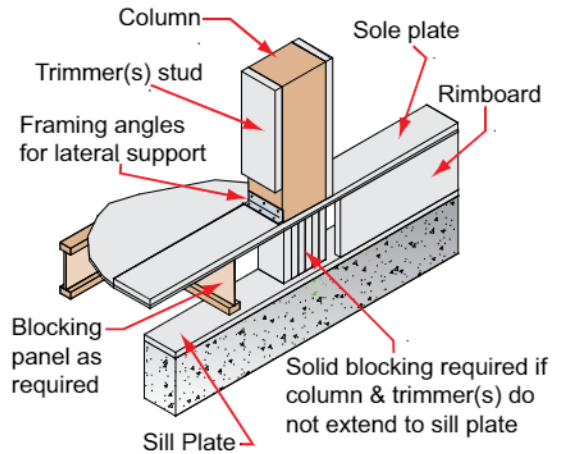

**3½" Studs - 24" o.c.**

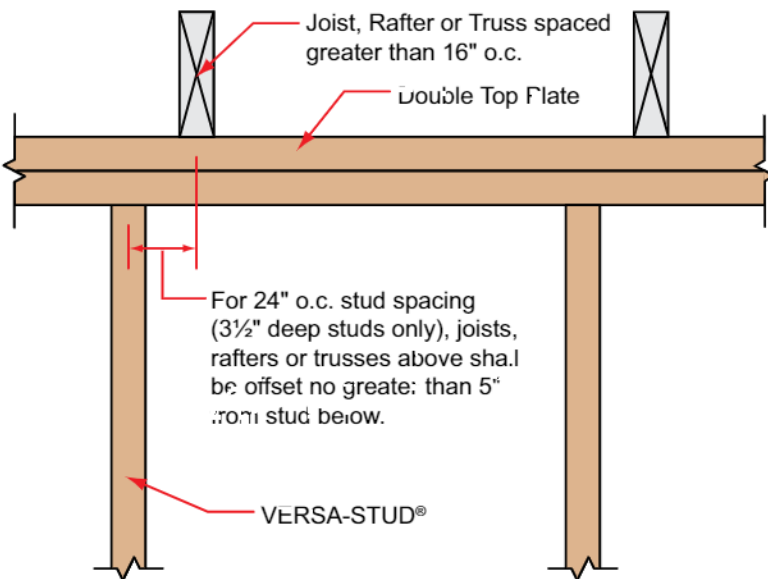

**Column to Top Plate**

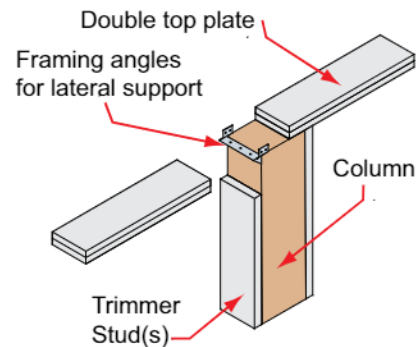



## VERSA-STUD® 1.7 2400 Nail Design Values

Nail Type	Nail Diameter	Nail Length	Lateral Capacity [lb]	Lateral End Grain Capacity [lb]	Lateral Toe Nail Capacity [lb]
8d box	0.113"	2.5"	116	78	96
8d common	0.131"	2.5"	143	96	119
10d box	0.128"	3"	148	99	123
10d common	0.148"	3"	188	126	156
12d box	0.128"	3.25"	148	99	123
12d common	0.148"	3.25"	188	126	156
16d box	0.135"	3.5"	165	111	137
16d sinker	0.148"	3.25"	188	126	156
16d common	0.162"	3.5"	225	151	187

**Notes**

- Nail values per 2005 National Design Specification (NDS) for Wood Construction.
- Nail values based upon a load duration factor of 1.60 and an equivalent specific gravity of 0.5.
- Lateral capacities based upon a side-member thickness of 1½".
- For end grain connections, a reduction factor of 0.67 is applied (NDS 11.5.2).
- For toe nailed connections a reduction factor of 0.83 is applied (NDS 11.5.4).

## Wall Connectors

### FRAMING ANGLES

**Simpson Strong-Tie**

Model No.	Length	Stud Size	Nailing	Allowable Load [lb]	
				F1	F2
A23	2¾"	3½"	(8) 10d x 1½"	565	585
A34	2½"	3½"	(8) 8d x 1½"	365	280
L30	3"	3½"	(4) 10d	240	240
LS30	3¾"	3½"	(6) 10d	395	-
L50	5"	5½"	(6) 10d	445	445
LS50	4¾"	5½"	(8) 10d	560	-
L70	7"	7¼"	(8) 10d	565	565
LS70	6¾"	7¼"	(10) 10d	665	-
L70	7"	7¼"	(8) 10d	565	565

**USP Structural Connectors**

Model No.	Length	Stud Size	Nailing	Allowable Load [lb]	
				F1	F2
A3	2¾"	3½"	(8) 10d x 1½"	590	600
AC3	2⅞"	3½"	(4) 10d x 1½"	285	320
MP3	3¾"	3½"	(6) 10d	485	-
AC5	4⅞"	5½"	(6) 10d x 1½"	555	555
MP5	4⅝"	5½"	(8) 10d	730	-
AC7	6⅝"	7¼"	(8) 10d	740	740
L70	5⅞"	7¼"	(10) 10d	910	-

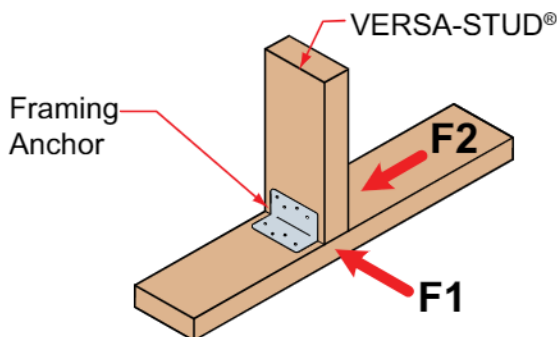

### STUD/PLATE TIES

**Simpson Strong-Tie**

Model No.	Nailing	Uplift [lb]
RSP4	(8) 8d x 1½"	315
SSP	(7) 10d x 1½"	350
DSP	(14) 10d x 1½"	775
SP1	(10) 10d	585
SP2	(12) 10d	1065

**USP Structural Connectors**

Model No.	Nailing	Uplift [lb]
RSPT4	(8) 8d x 1½"	470
RSPT6	(8) 10d x 1½"	700
RSPT6-2	(14) 10d x 1½"	955
SPT22	(8) 10d	725
SPT24	(12) 10d	1085

### HEADER CLIPS/HANGERS

**Simpson Strong-Tie**

Model No.	Width	Nailing	Allow Vertical Load [lb]
FC4	3 <sup>9</sup> / <sub>16</sub> "	(8) 16d	800
FC6	5½"	(10) 16d	920
HH4	3½"	(13) 16d	1195
HH6	5½"	(18) 16d	1595

**USP Structural Connectors**

Model No.	Width	Nailing	Allow Vertical Load [lb]
SFC4	3 <sup>9</sup> / <sub>16</sub> "	(8) 16d	550
SFC6	5½"	(10) 16d	690
HH44	3 <sup>9</sup> / <sub>16</sub> "	(13) 16d	1240
HH66	5½"	(18) 16d	1650

Connection values based upon a load duration factor of 1.6 and an equivalent specific gravity of 0.5.

## Base and Top Lateral Wind Reactions for Connectors [lb] 20 PSF Wind Load

See footnote 1 for conversions for other wind loads

Height [ft]	Stud / Column Tributary Width [in]										Note
	12	16	19.2	24	36	48	60	72	84	96	
8	80	107	128	160	240	320	400	480	560	640	1) For other wind loads, multiply reaction in table by the following factors: 10 PSF = 0.5 15 PSF = 0.75 25 PSF = 1.5 30 PSF = 1.5 40 PSF = 2.0
10	100	133	160	200	300	400	500	600	700	800	
12	120	160	192	240	360	480	600	720	840	960	
14	140	187	224	280	420	560	700	840	980	1120	
16	160	213	256	320	480	640	800	960	1120	1280	
18	180	240	288	360	540	720	900	1080	1260	1440	
20	200	267	320	400	600	800	1000	1200	1400	1600	
22	220	293	352	440	660	880	1100	1320	1540	1760	
24	240	320	384	480	720	960	1200	1440	1680	1920	

## VERSA-STUD® Allowable Holes and Notches

### Prescriptive Provisions

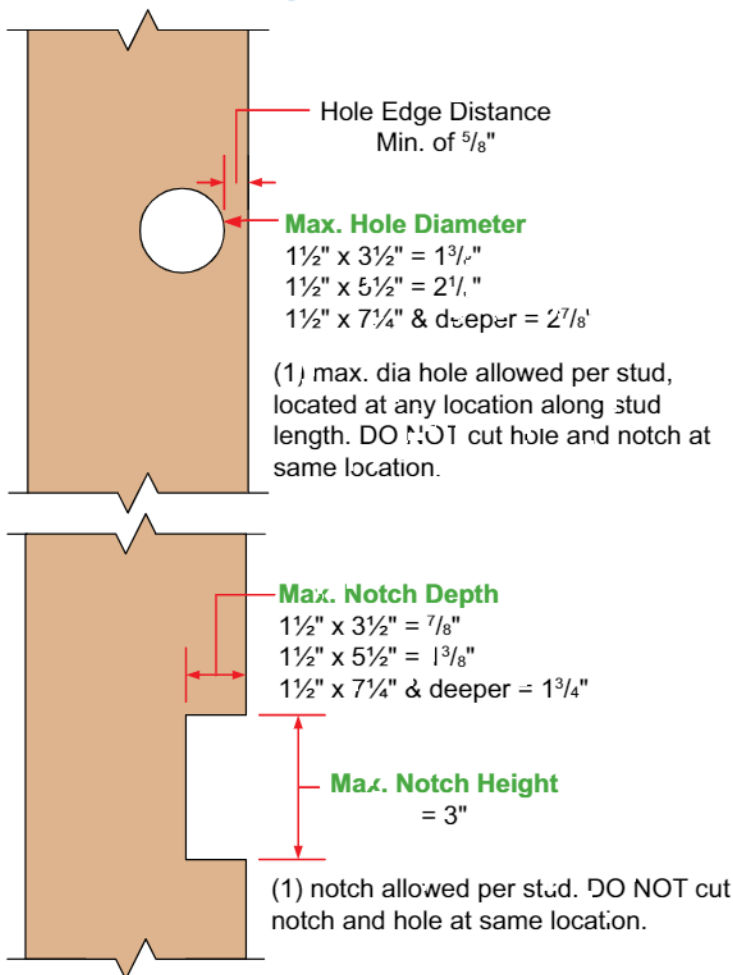

**Notes:**

- 1) Provisions valid only for studs within prescriptive design (see page 1)
- 2) Shield plates or nail stops to prevent nailing into wiring or piping shall be installed per the governing building code.

### Engineered Design Provisions

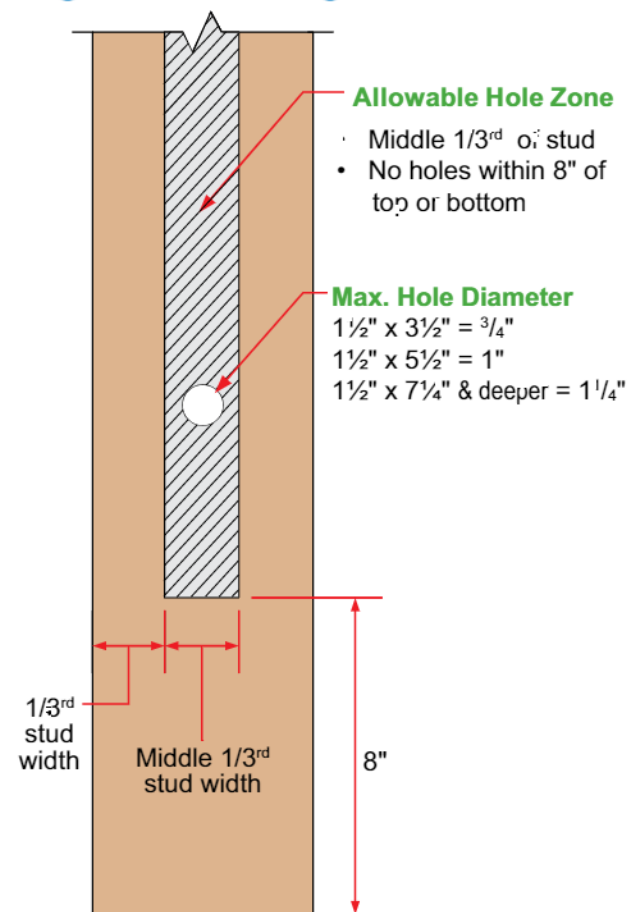

**Notes:**

- 1) DO NOT drill more than 3 holes in any 4-foot-long section of stud.
- 2) The vertical distance between adjacent holes must be at least 2 times the size of the larger hole.
- 3) Holes no greater than  $\frac{3}{4}$ " dia may be cut in the hole zone shown in VERSA-LAM® columns.
- 4) For notches and larger holes, contact Boise EWP Engineering.

### 1½" VERSA-STUD® 1.7 2400 Design Properties

Width [in]	Depth [in]	Weight [lb/ft]	Allowable Shear [lb]	Allowable Moment [lb-ft]	Moment of Inertia (I) [in <sup>4</sup> ]
1½	3½	1.3	998	702	5.4
1½	5½	2.1	1568	1649	20.8
1½	7¼	2.8	2066	2779	47.6
1½	9¼	3.6	2636	4404	98.9
1½	11¼	4.3	3206	6374	178.0

### VERSA LAM® 1.7 2650 Column Design Properties

Width [in]	Depth [in]	Weight [lb/ft]	Allowable Moment Edge <sup>(1)</sup> [lb-ft]	Allowable Moment Flat <sup>(1)</sup> [lb-ft]	Moment of Inertia (I) [in <sup>4</sup> ]
3½	3½	3.6	1810	1639	12.5
3½	5¼	5.4	3892	3525	42.2
3½	7	7.1	6702	6069	100.0
5¼	5¼	8.0	5838	5287	63.3
5¼	7	10.7	10053	9104	150.1
7	7	14.3	13403	12139	200.1

1) Allowable bending stress is 2650 psi on edge (parallel to gluelines), 2300 psi flat (perpendicular to gluelines)

### Allowable Stress Value Comparison

Product	Bending $F_b$ [psi]	Compression Parallel to Grain $F_c$ [psi]	Modulus of Elasticity E [psi]	Horizontal Shear $F_v$ [psi]
<b>VERSA-STUD® 1.7 2400</b>	<b>2400</b>	<b>3000</b>	<b>1700000</b>	<b>285</b>
Douglas fir #2 Grade	900	1350	1600000	180
Spruce Pine Fir (North) #1/2 Grade	875	1150	1400000	135
Hem-Fir #2 Grade	850	1300	1300000	150
Western Woods #2 Grade	675	900	1000000	135

- Design values are for loads applied to the narrow face of the studs.
- Dimension lumber values taken from 2005 Edition, NDS Design Values for Wood Construction (per 2005 ICC® IRC)
- Repeating member and size factors have not been applied.





## Prescriptive Nailing

Since VERSA-STUD® may be used in prescriptive design in the IBC and IRC, it may be installed as studs in braced wall panels. Standard nailing for prescriptive wood stud walls with structural sheathing is 6d common nails for panels  $\frac{5}{16}$ " to  $\frac{1}{2}$ " thick, 8d common nails for panels  $\frac{19}{32}$ " to 1" thick, spaced at 6" on-center on panel edges and 12" on-center in intermediate studs.

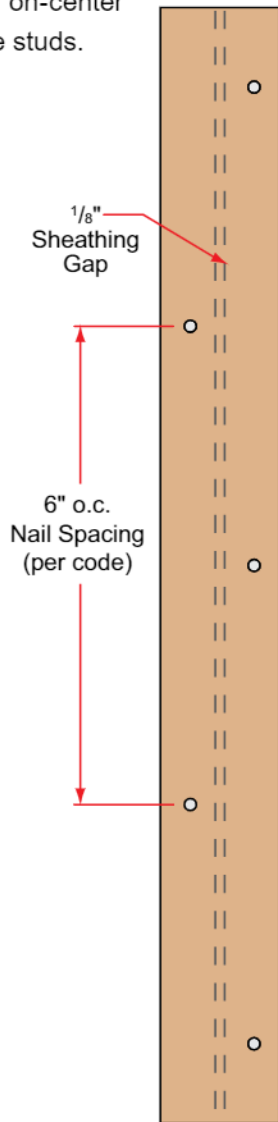

**Single Stud Nailing at Panel Edges**

## Shear Walls

VERSA-STUD® may be used in shear wall construction. Allowable shear values may be determined by using Table 2306.4.1 of the IBC, shear walls with Douglas fir-Larch framing, subject to the following conditions:

1. A double VERSA-STUD® must be used at all panel edges of shear walls. Studs must be stitch-nailed together with two rows of 10d common nails at 8" on-center, staggered.
2. Nails at panel edges must be staggered along two nailing lines spaced approximately  $\frac{1}{2}$ " apart. Nails at panel edges must also be at least  $\frac{3}{8}$ " from the edges of the VERSA-STUD® and the wood structural panel (see detail below).
3. The tabulated shear values for nailed wood structural panel shear walls using 8d or 10d box or common nails at a panel edge nailing of 2" must be multiplied by a factor of 0.9.
4. The tabulated shear values for nailed wood structural panel shear walls using 10d box or common nails at a panel edge nailing of 3" must be multiplied by a factor of 0.9.

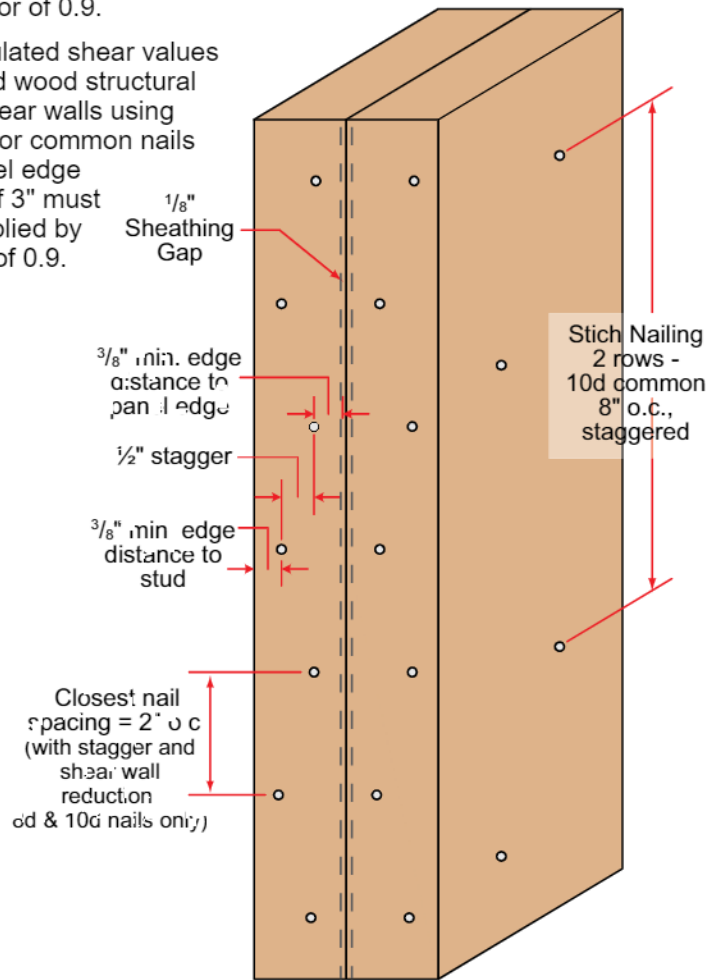

**Double Stud Nailing Edges Shear Wall Only**

## Fire Assemblies

VERSA-STUD® is permitted as a direct replacement for solid-sawn lumber in any fire-resistance-rated wall assembly listed in Table 720.1(2) of the IBC, provided the VERSA-STUD® have a minimum depth of  $\frac{5}{2}$ ".

Boise Cascade EWP is proud to introduce BC COLUMN®. BC COLUMN® is new software that will allow customers the ability to design columns using Boise Cascade Engineered Wood Products.



### Using BC COLUMN®, users can quickly:

- Design a column or stud using Boise Cascade Engineered Wood Products.
- Add gravity and out-of-plane lateral loads.
- Add bracing/supports.
- Select and test products in the design.
- Refine performance factors.
- Print design reports.

### The steps are simple. To use:

- Set up the project
- Launch BC COLUMN®.
- Enter project information.
- Specify the design and select a product.
- Describe the type of column or stud, its height and its bracing.
- Adjust the axial load and add additional out-of-plane lateral loads.
- Select a product. Specify the Deflection.
- Specify the column/stud deflection.
- Analyze and refine design.
- Review and print design reports.

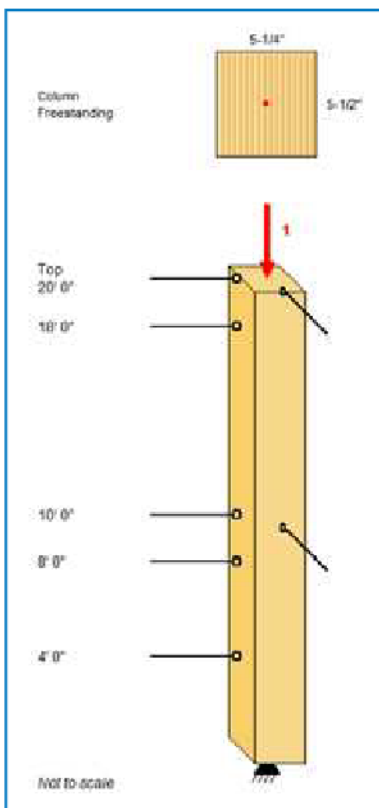
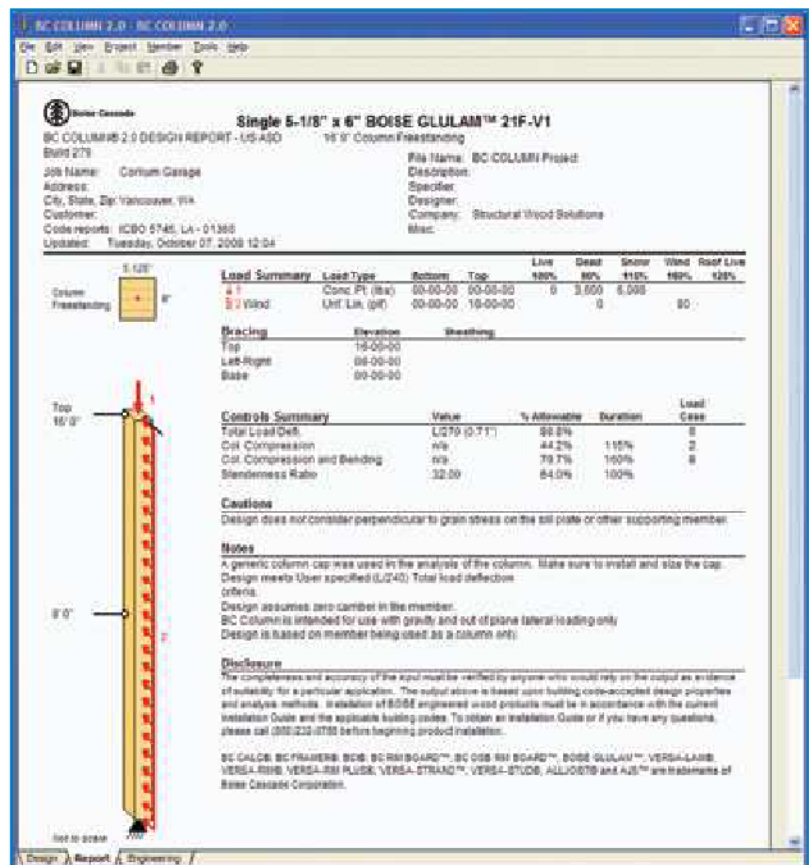
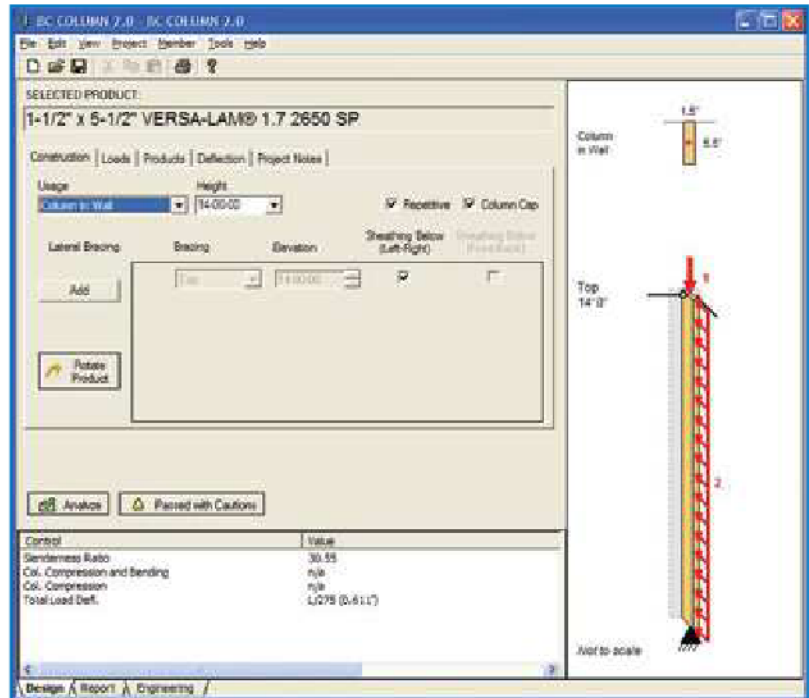

BC COLUMN® is installed with BC CALC for the US market ONLY.

To download or BC CALC/BC COLUMN® US

<http://www.bc.com/wood/ewp/software/bccalc.html>



New BC FRAMER® represents a huge technological leap to help you improve the efficiency and profitability of your engineered wood products business. Boise Cascade will provide you what we believe is now the industry's best design software, offering far greater productivity than even our current version of BC FRAMER®. This new software package will help your design department work faster and accomplish more. You don't get paid to do drawings, but at least now you can do them in less time, and better.

- Shrink design time with BC FRAMER® model sharing
- Save time & prevent mistakes with best-in-industry integration.
- Experience the efficiencies of BC FRAMER® whole house modeling.
- Draw floor and wall plans simultaneously with BC FRAMER®.
- Check the plan every possible way with BC FRAMER® full 3-D viewer.
- Create a master plan and multiple options that can be quickly selected and exported to a plot-specific file in a few minutes -- a fraction of the time it could have taken in the past.

information can also be obtained at 1-800-405-5969 or email us at [EWPSupport@BC.com](mailto:EWPSupport@BC.com).

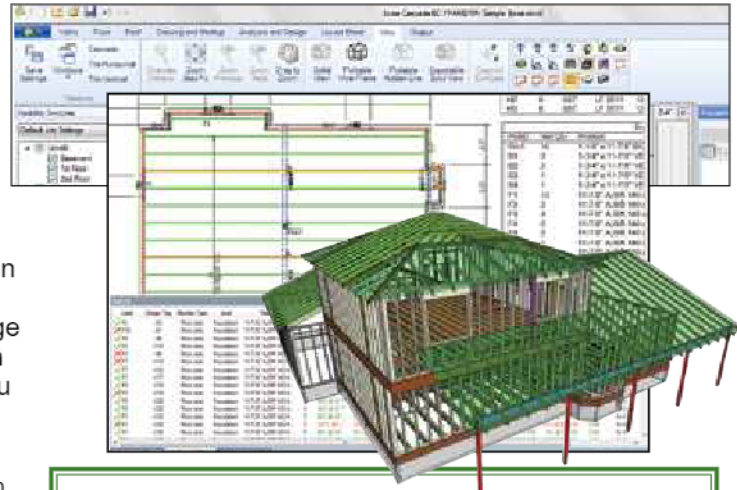

### RECOMMENDED HARDWARE

- **CPU:** Quad Core 64 bit Processor
- **L2 Cache:** 3MB/Core
- **RAM:** 4.0GB to 8.0 GB
- **Video:** Full support for DirectX 9; Single monitors. 1280x1024 128MB; Dual monitor. 1280x1024 256MB (Minimum: 1024x768;
- **Operating Systems:** Windows® 7 or 8 (Professional Editions 32-bit and 64-bit)

Actual specifications vary by user and will be assessed prior to installation.

## BC CALC® 4.0 Sizing Software

BC CALC® is simple to use, yet robust enough to analyze most all joist, beam, and column applications. Once an analysis is run, the user may print an easy-to-read design report that displays the span and load information with the analysis results.

BC COLUMN® has now been merged into BC CALC®, allowing the sizing of joists, beams, rafters, columns, and studs all in one convenient program.

In addition to BCI® & AJS® Joists, VERSA-LAM®, and BOISE GLULAM®, BC CALC® also offers the analysis of solid sawn lumber and timber members. Thus BC CALC® is the only program needed to analyze structural wood members.



Boise Cascade has provided BC CALC® free of charge to the design community since 1994.

### COMPUTER REQUIREMENTS

PC with any current version of MS Windows®, along with an internet connection. For questions regarding BC CALC®, call 1-800-405-5969 or email [EWPSupport@BC.com](mailto:EWPSupport@BC.com).

To Download BC CALC US,

<http://www.bc.com/wood/ewp/software/bccalc.htm>:

The screenshots show the BC CALC software interface. The top window displays 'SELECTED PRODUCT' for '3-1/2" x 6" BOISE GLULAM® Combination #3 DF'. Below this, there are sections for 'Analysis Parameters' and 'Design Report'. The design report includes a 'Reaction Summary' table and a 'Load Summary' table.

Response	Max	Min	Max	Min	Max	Min
DL	4.125 D	2.647 U				
DL + LL	4.125 D	2.647 U				

Load Description	Load Case	Max. Total	Min. Total	Max. Self	Min. Self	Max. Other	Min. Other	Max. Total	Min. Total
1. Selected Load	DL + LL	11.142 D	11.142 U	0.000	0.000	0.000	0.000	11.142 D	11.142 U



If in doubt ask! For the closest Boise Cascade EWP distributor/support center, call **1-800-232-0788**

Boise Cascade Engineered Wood Products build better homes with stronger, stiffer floors using only wood purchased in compliance with a number of green building programs. Take a moment to view our sustainability certification site at <http://www.bc.com/sustainability/certification.html> or view our green brochure at [http://www.bc.com/wood/ewp/Boise\\_EWP\\_Green.html](http://www.bc.com/wood/ewp/Boise_EWP_Green.html).

Boise Cascade Engineered Wood Products throughout North America can now be ordered FSC® Chain-of-Custody (COC) certified, enabling homebuilders to achieve LEED® points under

U.S. Green Building Council® residential and commercial green building programs including LEED for Homes and LEED for New Construction. Boise Cascade Engineered Wood Products are available as PEFC® Chain-of-Custody certified, SFI® Chain-of-Custody certified and SFI® Fiber-Sourcing certified, as well as NIAHB Research Center Green Approved, enabling homebuilders to also obtain green building points through the National Green Building Standard.

**Great products are only the beginning.®**

**Lifetime Guaranteed Quality and Performance**

Boise Cascade warrants its BCI® Joist, VERSA-LAM®, and ALLJOIST® products to comply with our specifications, to be free from defects in material and workmanship, and to meet or exceed our performance specifications for the normal and expected life of the structure when correctly stored, installed and used according to our Installation Guide.

For information about Boise Cascade's engineered wood products, including sales terms and conditions, warranties and disclaimers, visit our website at [www.BCewp.com](http://www.BCewp.com)

BOISE CASCADE, TREE-IN-A-CIRCLE, BCI, BC CALC, BC FRAMER, BC RIM BOARD, BOISE CASCADE, BOISE GLULAM, SIMPLE FRAMING SYSTEM, VERSA LAM, VERSA-RIM, VERSA STRAND, and VERSA STUD are trademarks of Boise Cascade, L.L.C. or its affiliate

Your Dealer is:

If no dealer is listed, call 1-800-232-0788



**Boise Cascade**  
Engineered Wood Products