

HIGHWAY CENTER STRIP KEYWAY SYSTEM

USES

- ❖ Used in concrete flatwork as a control or construction joint
- ❖ Tongue & Groove design provides excellent load transfer characteristics
- ❖ Used as a screed rail to finish the concrete

ADVANTAGES

- ❖ Eliminates costly form stripping and saw cutting.
- ❖ Radius formed key eliminates the sharp angles that produce spalling tendency
- ❖ ULTRA FINE profile at top edge eliminates surface voids, reduced spalling and produces architecturally pleasing joint lines in the finished slab.
- ❖ Channel Stakes double as a butt splice

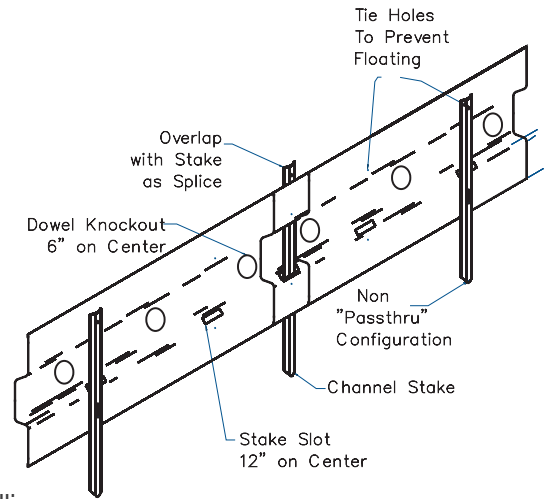

MATERIAL

- ❖ Keyway is made from 20 gauge HDMG Steel
- ❖ Dowel knockouts every 6 inches
- ❖ Available in 10ft lengths for 5", 6" 8" 9" & 10" slabs
- ❖ Channel Stakes are made from 16 gauge HRPO steel
- ❖ Available in 15" (HK15) lengths



Product Code	Slab Thickness	A	B	C	Knockout Diameter
HK45	5"	4 1/2"	2 3/4"	1"	7/8"
HK55	6"	5 1/2"	2 7/8"	1"	7/8"
HK65	7"	6 1/2"	3"	1"	7/8"
HK75	8"	7 1/2"	3 1/4"	1"	1 1/4"
HK85	9"	8 1/2"	3 1/2"	1"	1 1/4"
HK95	10"	9 1/2"	3 3/4"	1"	1 1/4"

