



CARLISLE'S
SURE-TOUGH™
REINFORCED EPDM ROOFING SYSTEMS

STRENGTH • EFFICIENT INSTALLATION • LONG-TERM PERFORMANCE





Sure-Tough™ EPDM Roofing Systems

Carlisle's Sure-Tough EPDM with Factory-Applied Tape seam technology combines the fastest installation methods with the toughest reinforced membranes. Sure-Tough consists of a tough polyester reinforcement sandwiched between two strong EPDM membrane plies. It's durable enough to handle high maintenance traffic abuse and is backed up by the industry's only accidental puncture warranty of up to 32 man-hours per year.

History of Carlisle

Carlisle pioneered EPDM roofing membranes more than 45 years ago and has established a strong track record of superior product durability and long-term weather resistance with over 15 billion square feet of membrane installed. EPDM, well known for its superior UV and ozone-weathering performance, is manufactured under quality-controlled conditions. A durability assessment of roofing membranes found EPDM was "the only membrane with no reduction in flexural fatigue resistance for all tests/locations."

A recent study of aged EPDM showed that after 26 years of real world exposure, EPDM still retained excellent tensile strength, tear resistance and weathering resistance.

Carlisle's innovative Factory-Applied Tape (FAT™) was recently recognized as one of the building industry's top 100 products based upon aesthetics, ease of use, durability/life-cycle, efficiency or applicability, universal appeal, sustainable/green elements and much more. FAT was acknowledged for addressing critical building issues and improving a building's overall performance.

Fast and Tough

Carlisle's FAT seam technology allows the building to get in the dry faster. Durable enough for installations that may encounter maintenance traffic, abuse or possible puncturing, Sure-Tough is often specified for schools, hospitals and manufacturing facilities.

Enhanced Installation Efficiency

The speed associated with the Sure-Tough system is a result of Carlisle's innovative Factory-Applied Tape (FAT). FAT seam technology has been proven to reduce seaming time by 75 percent and cut labor requirements when compared to other seaming methods available in the marketplace. FAT also reduces the risk of seam failure by delivering 30 percent greater peel strength and 32 percent greater shear strength than standard seaming methods.

Available in three-inch and six-inch widths, FAT is applied in a factory-controlled setting. FAT seam technology provides uniform adhesive width and thickness and also increases installation speed while reducing the risk of human error during seam installation. Consistent coverage of FAT also maximizes the splice area within plus or minus one-eighth of an inch, improves the ability to get the building in the dry in less time and minimizes business disruption.



Increased Strength and Performance

Sure-Tough membranes get their strength from a strong polyester reinforcing scrim sandwiched between two plies of Carlisle's time-tested EPDM rubber. The reinforcement more than doubles the puncture resistance compared to non-reinforced membranes. Due to its dual-ply construction that makes it resistant to cuts, tears and scuffs, the Sure-Tough system is ideal for rooftops where long-term performance and protection is absolutely essential. Thicker membranes offer greater thickness over scrim and therefore superior longevity and better scuff resistance. All Sure-Tough membranes can be backed by total system warranties, including the industry's only accidental puncture warranty. With accidental puncture warranties available to the building owner, Carlisle stands up for Sure-Tough performance by making limited repairs to unexpected damages in the membrane.

Federal 101C Puncture Test Sure-Tough Reinforced EPDM Membranes

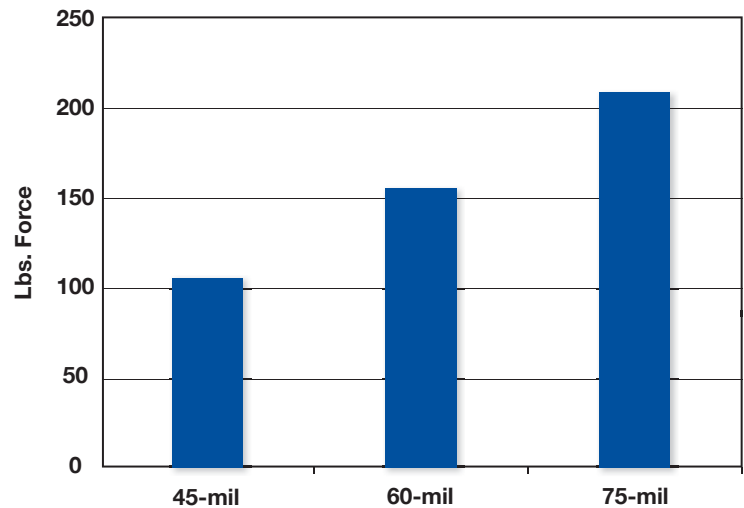

Lightweight and Powerful

Fully Adhered Roofing System

Sure-Tough reinforced membrane may be utilized on Carlisle's Fully Adhered Roofing System installations. An acceptable insulation is mechanically fastened to the roof deck or adhered with FAST™ Adhesive, and the membrane is adhered to the insulation with Carlisle's EPDM Bonding Adhesive. Adjoining sheets of membrane are spliced using Carlisle's Factory-Applied Tape (FAT).

- Less than ½ pound per square foot
- Can be warranted for wind speeds of up to 120 miles per hour
- System performance up to 20 years

Strong and Versatile

Mechanically Fastened Roofing System

Sure-Tough can be integrated with Carlisle's Mechanically Fastened Roofing System. Insulation is mechanically fastened to the roof deck, and the membrane is mechanically fastened with fastening plates, polymer or metal fastening bars and the appropriate fasteners as specified in Carlisle's Specifications and Details.

Adjoining Sure-Tough sheets are spliced together using Carlisle's Factory-Applied Tape (FAT). Enhanced securement is achieved around the roof perimeter using RUSS (Reinforced Universal Securement Strip) under the membrane.

- Can be warranted for wind speeds of up to 100 miles per hour
- Dead-level to 18:12 slopes can be accommodated
- Provides exceptional performance in a lightweight, cost efficient, rapid installation

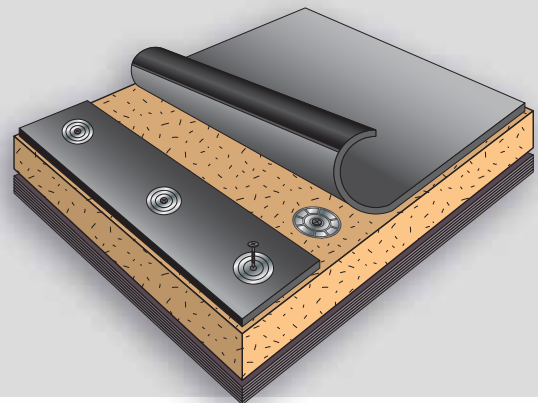
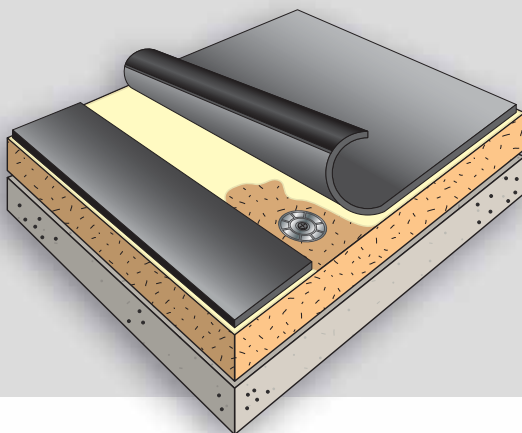

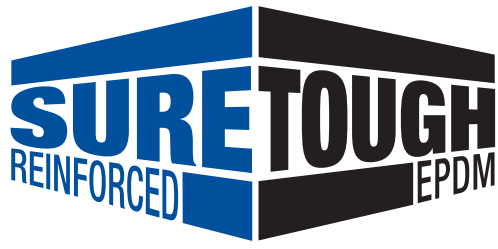

Sure-Tough Roofing System Accessories

- Insulation
- Fasteners
- Bonding Adhesives
- FAT seam technology
- Pressure-Sensitive Flashings
- SecurEdge™ coping, fascia and drip edge

