

Sure-Weld[®] TPO
Roofing Systems



10 Reasons Why There is Still No Equal



After nearly **20 years**, there's **Still No Equal**

Thermoplastic polyolefin (TPO) is the fastest-growing segment in the commercial roofing industry. To take advantage of this recent popularity, a growing number of companies have begun offering TPO single-ply membranes. Unfortunately, not all TPO is created equally. Your building deserves a TPO roofing system provided by the manufacturer that has been at the forefront of TPO research, development and technology since the inception of TPO as a roofing membrane: **Carlisle SynTec Systems.**

Here are **10 things** to consider when investing in a **TPO roofing system**.

1

EXPERIENCE AND INNOVATION:

There is no substitute

Carlisle: Over 50 years of single-ply manufacturing experience. Leading the industry in TPO research and development for nearly 20 years. More than three billion square feet of Carlisle Sure-Weld TPO membrane has been installed on rooftops across the globe. That's more than any other manufacturer.

The Other Guys: Minimal manufacturing, warranty and installation experience in some cases.

Protect Your Investment: Require that your TPO membrane be manufactured by a company with at least 10 years of TPO manufacturing experience.

2

WEATHERING PACKAGE:

Like sunblock for your roof

Carlisle: Xenon arc and long-term heat aging shows that Carlisle's TPO membrane tests to the highest standards in the industry. That's because every TPO membrane is enhanced with OctaGuard XT™ Weathering Package, a unique eight-component blend of antioxidants, UV absorbers, as well as light and heat stabilizers that results in the most dependable, long-term performance characteristics in the industry.

The Other Guys: Only meet the basic requirements established by ASTM.

Protect Your Investment: Ensure that your TPO roofing system will withstand the highest temperatures and UV exposures by investing in a membrane that can withstand over 52 weeks at 240°F and a minimum of 20,000 kJ/m² xenon arc resistance at 80°C without cracking or showing signs of material failure.

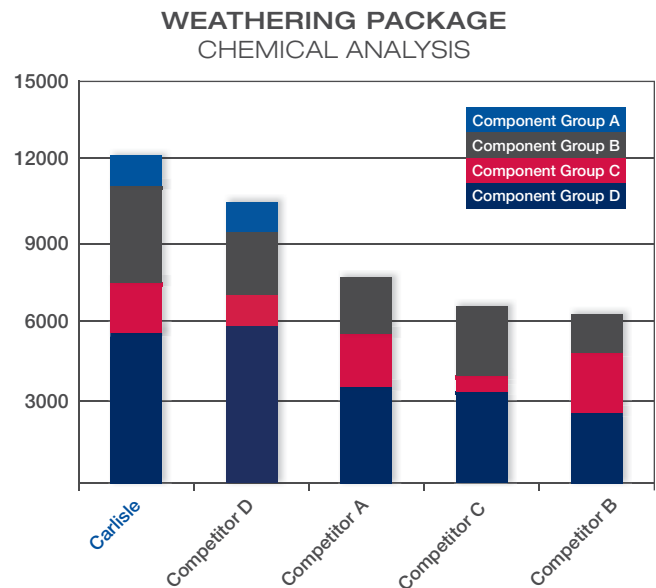

Carlisle TPO with OctaGuard XT

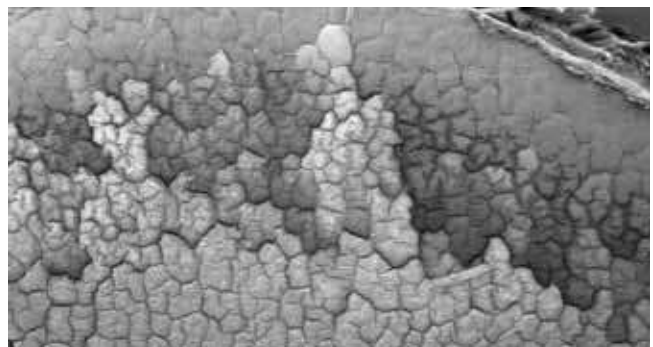

The Other Guys

45-mil TPO membrane at 50x magnification after extreme simulated UV exposure.



4

WELDABILITY: Don't let weather get you down

Carlisle: TPO membranes can be welded at the widest temperature and humidity ranges resulting in strong welds without having to modify welder settings to compensate for changing climatic conditions. This leads to greater productivity and more reliable seams.

The Other Guys: For sheets with a narrow window of weldability, welder settings must be altered to account for changes in temperature and humidity, which can slow down installations and increase costs. Weaker, improper or “cold” welds may also occur, which may lead to leaks in your roofing system.

Protect Your Investment: Improper welds are the most common and costly mistakes made on a TPO roofing system, so choose a membrane that provides the widest window of weldability to produce strong seams.

3

SEAM STRENGTH: It is what it seams

Carlisle: Independent tests show that Carlisle’s TPO membrane exhibits far stronger seams than competing products. That means better wind uplift performance with fewer leaks and callbacks.

The Other Guys: May require cumbersome and expensive welding equipment or double welds to achieve adequate wind uplift and seam-strength performance, leading to increased labor costs and installation times.

Protect Your Investment: A strong seam is a vital part of any TPO roofing system. Request that the TPO manufacturer provide seam weld strength testing results greater than 60 Lbf/in at a wide range of welding temperatures and speeds.

5

ENERGY EFFICIENCY: Reducing your air conditioning consumption

Carlisle: White TPO membrane features an initial ENERGY STAR® solar reflectance of .79 and emissivity of .90. Carlisle’s tan TPO membranes are also ENERGY STAR qualified, having met and exceeded the program’s energy efficiency guidelines.

The Other Guys: Produce a TPO membrane with good initial reflectivity numbers that fall off dramatically when tested by ENERGY STAR for three-year aged reflectivity.

Protect Your Investment: Maximize the energy efficiency of your roof and require that the TPO installed on your building has the highest Cool Roof Rating Council three-year reflectivity rating.

SEAM STRENGTH MEASURED IN LBF/IN

Speed Ft/M	Carlisle				Competitor A				Competitor C			
	7.9	10.5	13.5	16.1	7.9	10.5	13.5	16.1	7.9	10.5	13.5	16.1
806°F	61	65	64	65	35	40	38	43	57	60	57	58
1004°F	62	64	68	62	39	44	39	38	60	60	58	58
1148°F	65	64	68	66	41	39	38	43	65	61	56	57



6

APPEARANCE: Keeping the roof clean

Carlisle: A combination of our state-of-the-art manufacturing process and over 15 years of manufacturing experience creates a smoother top surface designed to resist dirt, debris, mildew and bacteria build-up. That means you get a cleaner, more solar reflective membrane throughout the life of your roof, and Carlisle will back it with an industry-leading reflectivity warranty.

The Other Guys: May have coarse, rough and uneven surfaces that hold dirt and reduce reflectivity.

Protect Your Investment: A smooth surface is the best way to maintain high reflectivity values, so stick with the TPO roof system that offers the best protection against dirt and debris.

7

DIVERSITY AND VERSATILITY: No two roofing projects are ever the same

Carlisle: Carlisle manufactures TPO membranes with a wide range of thicknesses, widths, lengths and colors. Membrane thicknesses include 45, 60 and 80 mils with sheets as wide as 12 feet. All variations of thickness and width are available in white, gray and tan, as well as 16 special colors. If 100-foot sheet lengths aren't the most efficient for your project, TPO field membrane sheets can be manufactured in additional lengths.

The Other Guys: Limited in thickness, width and color and some only offer standard 100-foot length sheets. This condensed product offering restricts your ability to get the perfect TPO membrane for your roofing project.

Protect Your Investment: Ensure that you get the best roof for your money by giving your roofing contractor the choices he needs to save time and labor on your next TPO project.

8

THICKNESS OVER SCRIM: Thicker is better

Carlisle: 60-mil TPO features a typical thickness over scrim well above the required ASTM minimum. This thickness leads to greater weathering resistance with more OctaGuard XT Weathering Package for added protection against solar heat and UV. In addition to a thicker top ply, equal embedment of the scrim also provides increased lamination strength.

The Other Guys: Many TPO membranes narrowly exceed ASTM's minimum thickness over scrim requirement, which could mean a thinner top ply and less overall protection. By embedding the scrim in the bottom-ply, some manufacturers publish misleading thickness over scrim values, when in fact they are providing less top ply protection.

Protect Your Investment: The top ply of your TPO membrane is the first and best defense your building has against harmful weather, so be certain that your next TPO roof system features an optimal thickness over scrim.

THICKNESS OVER SCRIM
60-MIL TPO MEMBRANE

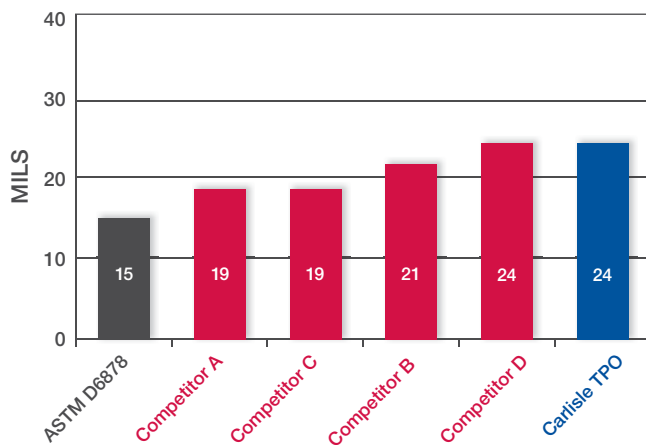

CROSS-SECTION OF TPO MEMBRANE

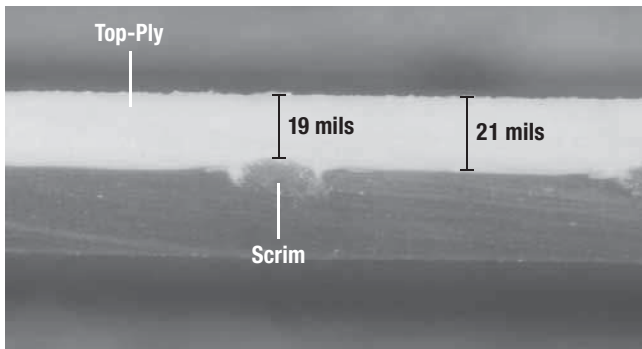

The Other Guys

9

WARRANTIES: Protection you can truly count on

Carlisle: With Carlisle, you can rest assured that your building will have outstanding warranty protection. Carlisle's Total System warranties, as well as an established warranty reserve, reflect a commitment and ability to address any warranty issue.

The Other Guys: May not publish or provide information about their warranty reserve.

Protect Your Investment: Ensure that the company providing your warranty has a properly funded warranty reserve and "No Dollar Limit" Total System warranties.

10

PREFABRICATED ACCESSORIES: Doing the hardest work for you

Carlisle: Carlisle offers over a dozen prefabricated, in-stock, standard-order accessories and countless custom-order accessories. All carry a CFA (Certified Fabricated Accessory) stamp of approval, so you know they are manufactured to the highest standards. Every Carlisle CFA-approved accessory saves time and money during installation.



The Other Guys: Many manufacturers only offer a limited number of accessories, while others carry products that have not been certified for quality.

Protect Your Investment: A typical roof can have hundreds of penetrations. Ensure that these pipes, curbs and other obstructions are properly waterproofed with TPO accessories certified by the TPO membrane manufacturer issuing your warranty.

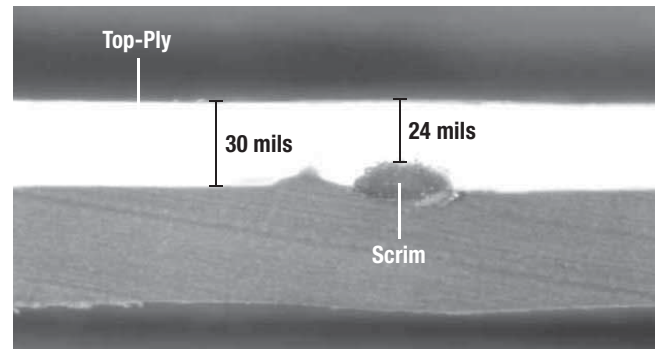

Carlisle TPO

EXPERIENCE THE CARLISLE DIFFERENCE

FULLY ADHERED TPO ROOFING SYSTEM

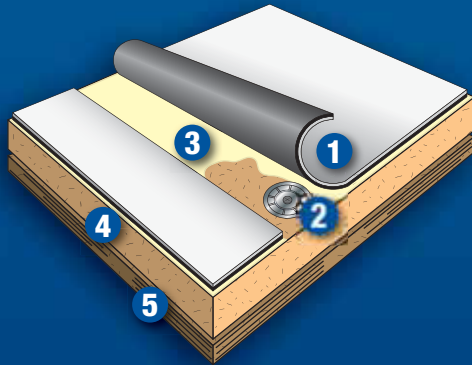

1. Sure-Weld TPO Membrane
2. Carlisle Insulation Fasteners and Plates
3. Sure-Weld TPO Bonding Adhesive
4. Acceptable Insulation
5. Approved Roof Deck

MECHANICALLY FASTENED TPO ROOFING SYSTEM

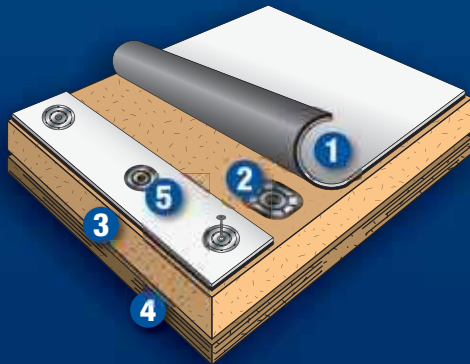

1. Sure-Weld TPO Membrane
2. Carlisle Insulation Fasteners and Plates
3. Acceptable Insulation
4. Approved Roof Deck
5. Membrane Fasteners and Plates

SELF-ADHERING TPO ROOFING SYSTEM

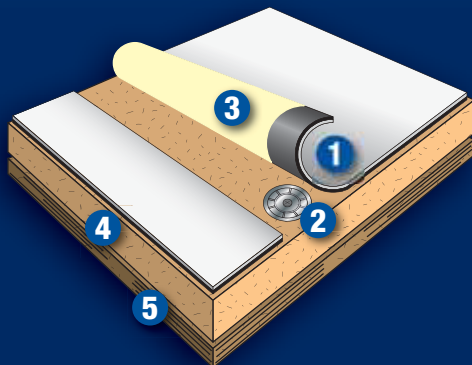

1. Self-Adhering Technology (SAT™) TPO Membrane
2. Carlisle Insulation Fasteners and Plates
3. Pre-Applied Adhesive
4. Acceptable Insulation
5. Approved Roof Deck



800-479-6832 | P.O. Box 7000 | Carlisle, PA 17013 | Fax: 717-245-7053 | www.carlisesyntec.com