



Steel Framing and Metal Lath

METAL LATH PLASTERING ACCESSORIES



www.cemcosteel.com





Steel Framing and Metal Lath

TABLE OF CONTENTS FOR METAL LATH

1. Metal Lath

a. Expanded Metal Lath and "D"	2
b. Self Furring Dimpled Metal Lath and "D"	2
c. Self Furring Grooved Metal Lath and "D"	2
d. CEM-LATH "K"	2
e. 1/8" Flat-Rib.....	3
f. 1/8" Flat-Rib Metal Lath with K-Paper.....	3
g. 3/8" Hi-Rib Metal Lath.....	3
h. 3/8" Hi-Rib Metal Lath with K-Paper.....	3

2. Corner and Casing Beads, Screeds

a. 1-A Cornerbead.....	4
b. 2-A Cornerbead.....	4
c. Smooth Edge Cornerite.....	4
d. CEMCORNER (all configurations).....	4
e. Stripite.....	5
f. #66 Short Flange Casing.....	5
g. #66 Expanded Flange Casing.....	5
h. # 7 Foundation Sill Screed.....	5
j. #34 Foundation Sill Screed.....	6
j. #36 Foundation Sill Screed.....	6
k. CEMCO J-Metals.....	6

3. Control and Expansion Joints

a. Double "J" (#XJ-15) Control Joint.....	6
b. Double "V" (#15) Control Joint.....	7
c. #30 Corner Control Joint.....	7
d. #093 ZINC Control Joint.....	7
e. Patches.....	7

4. Notes

- a. All product specification sheets available at www.cemcosteel.com
- b. For specific questions about application, installation, technical issues,
etc. contact CEMCO's technical services department at 800-416-2278

EXPANDED DIAMOND METAL LATH

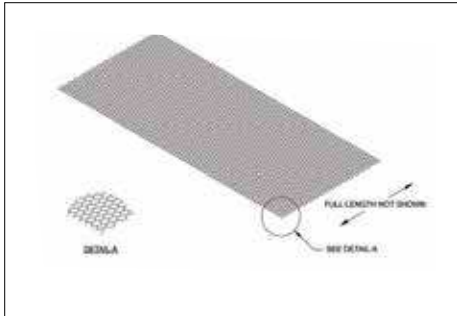

CEMCO's Diamond Metal Lath is a versatile base for cement plaster walls. Its carefully formed diamond keys allow for proper embedment and keying of the scratch coat on all types of walls. Can be used with hand and machine applied plaster. This lath is available with or without Grade D asphalt paper backing. All CEMCO expanded metal lath is produced from standard G60 hot-dipped galvanized steel. G90 is available upon special request.

Wt./Sq. Yd. (lbs)	Sheet Size	Pcs./Bundle	Yds./Pallet
1.75	27" x 96"	10	1000
2.5	27" x 96"	10	1000
2.5	27" x 96"	10	1000

Note: 50 bundles per pallet
25 bundles per pallet for "Dpaper-backed lath".

SELF FURRING DIMPLED METAL LATH

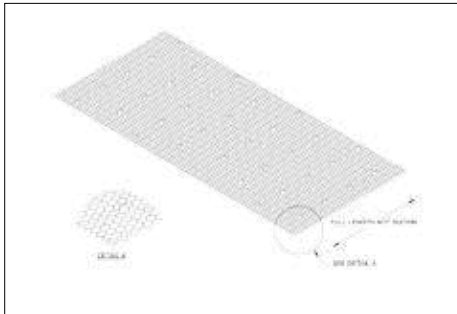

CEMCO's Self Furred Diamond Metal Lath "Dimpled" is manufactured with a 1/4" dimples in the lath. The dimples provide the necessary 1/4" furring off the sheathing's surface to allow for proper embedment and keying of the scratch coat on all types of walls. This lath is available with or without Grade D asphalt paper backing. All CEMCO expanded metal lath is produced from standard G60 hot-dipped galvanized steel. G90 is available upon special request.

Wt./Sq. Yd. (lbs)	Sheet Size	Pcs./Bundle	Yds./Pallet
1.75	27" x 96"	10	500
2.5	27" x 96"	10	500
3.4	27" x 96"	10	500

Note: 25 bundles per pallet

SELF FURRING GROOVED METAL LATH

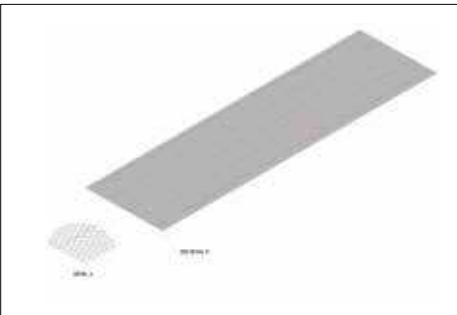

CEMCO's Self Furred Diamond Metal Lath "Grooved" is manufactured with 5 "V"-grooves in the lath in lieu of standard "dimples". These 5 grooves provide the necessary 1/4" furring off the sheathing's surface to allow for proper embedment and keying of the scratch coat on all types of walls. This lath is available with or without Grade D asphalt paper backing. All CEMCO expanded metal lath is produced from standard G60 hot-dipped galvanized steel. G90 is available upon special request.

Wt./Sq. Yd. (lbs)	Sheet Size	Pcs./Bundle	Yds./Pallet
2.5	27" x 96"	10	500
3.4	27" x 96"	10	500

Note: 25 bundles per pallet

CEM-LATH "K"

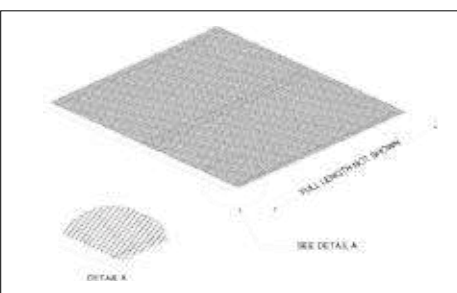

CEMCO's CEM-LATH "K" is a general purpose 3.4 lb. expanded diamond mesh lath with two 12" strips of "K" (Kraft) paper securely glued on as backing. CEM-LATH "K" is self-furring to ensure positive keying of hand-applied plaster and machine-applied plaster in wall applications. All CEMCO expanded metal lath is produced from standard G60 hot-dipped galvanized steel. G90 is available upon special request.

Wt./Sq. Yd (lbs)	Sheet Size	Pcs./Bdl.	Yds./Bdl.	Yds./Pallet
3.4	27" x 48"	10	10	250
3.4	27" x 96"	10	20	500

Note: 25 bundles per pallet

1/8" FLAT-RIB LATH

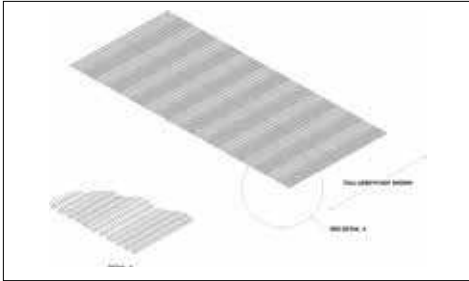

CEMCO's Flat rib lath is more rigid than diamond mesh lath by incorporating 1/8" longitudinal ribs every 3" on center, allowing for greater spans between wooden or steel supports. The small openings provide excellent keying of plaster. All CEMCO ribbed metal lath is produced from standard G60 hot-dipped galvanized steel. G90 is available upon special request.

Wt./Sq. Yd (lbs)	Sheet Size	Pcs./Bdl.	Yds./Bdl.	Yds./Pallet
2.0	27" x 48"	10	10	500
2.0	27" x 96"	10	20	1000

Note: 50 bundles per pallet.

1/8" FLAT-RIB LATH WITH K-PAPER (CEMMESH)

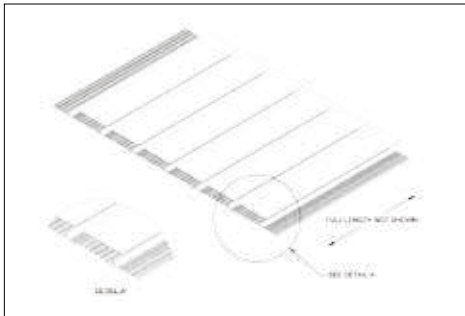

CEMCO's Flat rib lath with K-Paper (CEMMESH) is also more rigid than diamond mesh lath by incorporating 1/8" longitudinal ribs every 3" on center, and is a suited for machine applied plaster due to the K-Paper between the ribs that provide good backing during application. All CEMCO ribbed metal lath is produced from standard G60 hot-dipped galvanized steel. G90 is available upon special request.

Wt./Sq. Yd (lbs)	Sheet Size	Pcs./Bdl.	Yds./Bdl.	Yds./Pallet
2.0	27" x 48"	10	10	500
2.0	27" x 96"	10	20	500

Note: 50 bundles per pallet for 48" Flat-Rib K-Paper
25 bundles per pallet for 96" Flat-Rib K-Paper

3/8" HI-RIB LATH

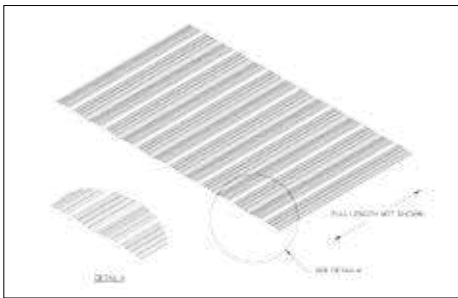

CEMCO's 3/8" Hi-Rib Lath is the most rigid of all metal laths. With full 3/8" ribs running longitudinally, and a 1/8" rib between them, Hi-Rib lath is able to span up to 24" on center. This lath can be used in both vertical and horizontal applications. All CEMCO ribbed metal lath is produced from standard G60 hot-dipped galvanized steel. G90 is available upon special request.

Wt./Sq. Yd (lbs)	Sheet Size	Pcs./Bdl.	Yds./Bdl.	Yds./Pallet
3.4	27" x 96"	10	20	1000

Note: 50 bundles per pallet

3/8" HI-RIB LATH WITH K-PAPER

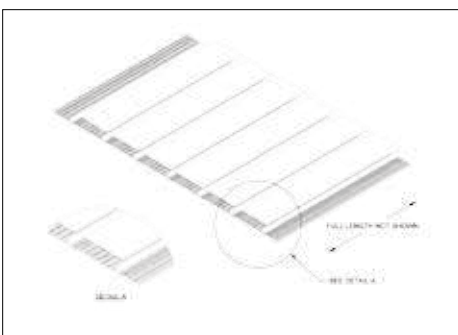

CEMCO's 3/8" Hi-Rib Lath is the most rigid of all metal laths. With full 3/8" ribs running longitudinally, and a 1/8" rib between them, Hi-Rib lath is able to span up to 24" on center. The 3" strips of K-Paper attached to the spaces between the 3/8" ribs to minimize blow through of plaster when machine applied. This lath can be used in both vertical and horizontal applications. All CEMCO applications ribbed metal lath is produced from standard G60 hot-dipped galvanized steel. G90 is available upon special request.

Wt./Sq. Yd (lbs)	Sheet Size	Pcs./Bdl.	Yds./Bdl.	Yds./Pallet
3.4	27" x 96"	10	20	1000

Note: 50 bundles per pallet

1-A CORNER BEAD

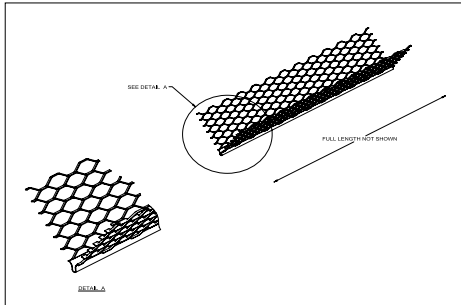

CEMCO's No. 1-A Expanded Corner Bead is manufactured with 2-5/8" expanded metal flanges and a solid metal nose to provide for clean and sharp corners even over slightly irregular surfaces. CEMCO's No. 1-A Expanded Metal Corner Bead is manufactured by Niles and distributed by CEMCO.

Size	Pcs./Ctn.	Ft./Ctn.	Wt./Ctn.	Ctn./Pkt.
8'	30	240	40 lbs.	40
9'	30	270	45 lbs.	40
10'	30	300	50 lbs.	40
12'	30	360	60 lbs.	40

2-A CORNER BEAD

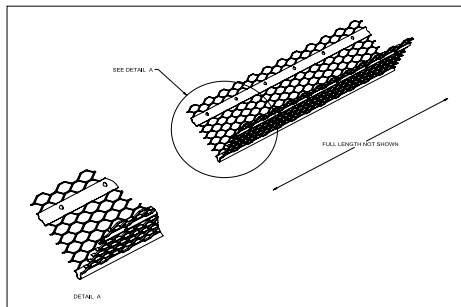

CEMCO's 2-A Expanded Corner Bead is manufactured with extra long 3-1/4" flanges and a reinforced steel rib running the entire length of the piece to provide for extra rigidity when nailing to the corner. CEMCO's 2-A Corner Bead is manufactured by Niles Inc., and distributed by CEMCO.

Size	Pcs./Ctn.	Ft./Ctn.	Wt./Ctn.	Ctn./Pkt.
8'	30	240	42 lbs.	25
9'	30	270	52 lbs.	25
10'	30	300	52 lbs.	25
12'	30	360	63 lbs.	25

SMOOTH EDGE CORNERITE

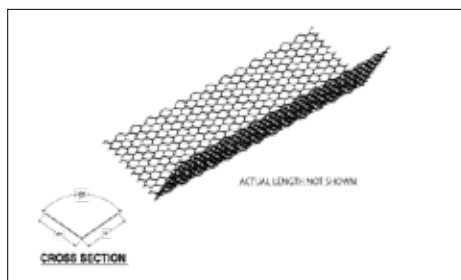

CEMCO's Cornerite is a smooth edge expanded metal lath corner reinforcement formed at a 105° angle to ensure a snug fit. This product also easily flattens for general patching. Cornerite is manufactured from steel meeting 0.016" thickness.

Size	Pcs./Ctn.	Ft./Ctn. (ft)	Wt./Ctn. (lbs)	Ctns./Pallet
2" x 2" x 4'	125	500	39	20
2" x 2" x 8'	75	600	47	18
3" x 3" x 4'	75	300	34	9
3" x 3" x 8'	75	600	69	16

CEMCORNER

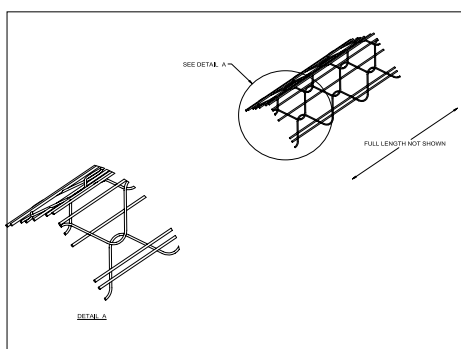

CEMCO's CEMCORNER is used as an exterior corner reinforcement that has a nailing strip along both sides for faster installation and straighter corners. CEMCORNER was designed so that it is easier for Portland cement plaster to flow into the nose of the CEMCORNER. CEMCORNER is available in standard straight, straight arch, bullnose, bullnose arch, and a special bullnose-shortflange to accommodate almost every conceivable corner application.

Product	Length	Ft. per Carton	Ctns./Pallet
Straight	8'	320	24
Straight	9'	360	24
Straight	10'	400	24
Straight Arch	10'	400	24
Straight Short Flange	10'	400	24
Bullnose	8'	320	24
Bullnose	9'	360	24
Bullnose	10'	400	24
Bullnose Arch	10'	400	24
Bullnose Shortflange	10'	400	24

STRIPITE

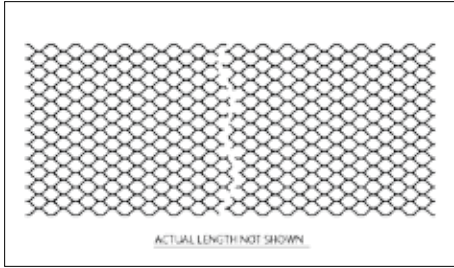

CEMCO's Stripite product is a general purpose expanded metal lath for plaster reinforcement. Stripite is a perfect addition to doors, windows, and other areas where cracking will most likely occur. Stripite is also used as a grout stop in cement block construction.

Size	Wt./Mlf.	Ft./Ctn.	Pcs./Ctn.	Ctn./Pallet
4" x 8'	78 lbs.	600'	75	18
6" x 8'	115 lbs.	600'	75	18

#66 SHORT-FLANGE CASING BEAD

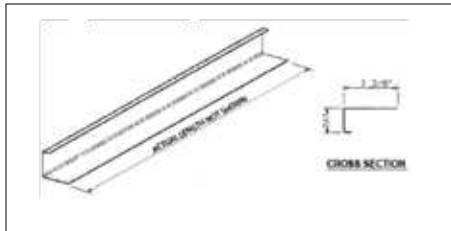

CEMCO's #66 short-flange casing bead has a short 90-degree turn at the plaster surface for a clean and neat finish at the end of a wall or when adjoining dissimilar material. This product is manufactured with a slight arch in the nailing flange to ensure a tight fit.

Size	Wt./Mlf.	Pcs./Ctn.	Length	Ft./Ctn.	Wt./Ctn.	Ctn./Pallet
3/8"	121 lbs.	30	10'	300'	36 lbs.	30
1/2"	129 lbs.	30	10'	300'	39 lbs.	30
3/4"	145 lbs.	30	10'	300'	44 lbs.	30
7/8"	153 lbs.	30	10'	300'	46 lbs.	30
1"	161 lbs.	30	10'	300'	48 lbs.	30
1-1/4"	173 lbs.	30	10'	300'	52 lbs.	30

#66 EXPANDED FLANGE CASING BEAD

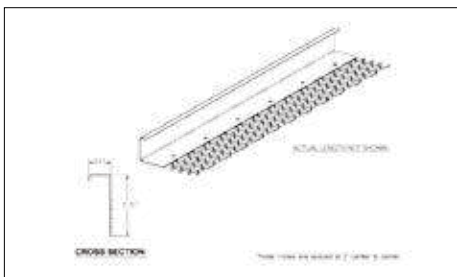

CEMCO's #66 expanded flange casing bead formed to a 90° for applications at inside corners. Absorbs movement due to expansion and contraction of plastered walls. Provided with an expanded flange for proper keying and easy application.

Size	Pcs./Ctn.	Length	Ft./Ctn.	Wt./Ctn.	Ctn./Pallet
1/4"	30	10'	300'	42 lbs.	42
3/8"	30	10'	300'	44 lbs.	42
1/2"	30	10'	300'	44 lbs.	42
3/4"	30	10'	300'	50 lbs.	42
7/8"	30	10'	300'	50 lbs.	42
1"	30	10'	300'	52 lbs.	42
1-1/4"	30	10'	300'	57 lbs.	42

#7 FOUNDATION SILL SCREED

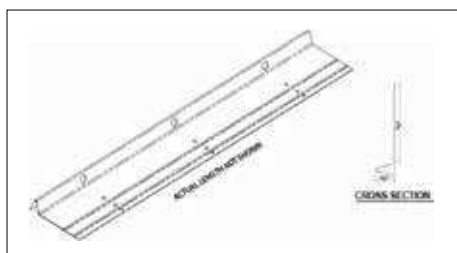

CEMCO's No. 7 Foundation Sill Screed is commonly known as FHA Screed due to its meeting of FHA requirements. Nailed or stapled to the sill plate, it provides a straight line stucco stop. Manufactured with 1/2" holes, the sill screed allows for water and moisture to weep from the exterior plaster system and away from the structure.

Size	Ground	Steel Thickness	Flange Size	Wt./mlf (lbs)	Length	Pcs./Bdl.	Pcs./Pallet
5 1/2"	7/8"	.019"	3-1/2"	303	10'	10	1000
5 1/2"	1-3/8"	.019"	3-1/2"	359	10'	10	500

#34 SILL SCREED

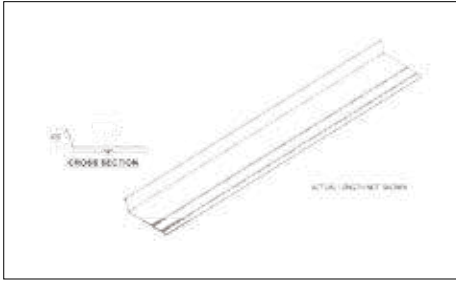

CEMCO's No. 34 sill screed is like the 5-1/2" FHA sill screed, but with a rounded screed point, that sheds water away from the exterior finish.

Size	Ground (G)	Steel Thickness	Flange Size	Wt./Mlf.	Length	Pcs./Bdl.	Pcs./Pallet
5 1/2"	7/8"	.019"	3-1/2"	307 lbs.	10'	10	1000

#36 FOUNDATION SILL SCREED

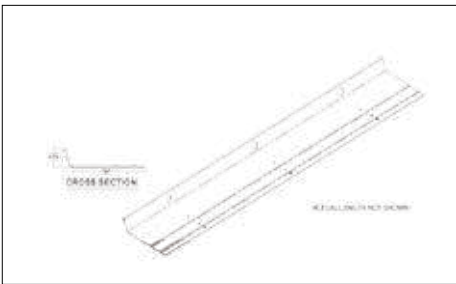

CEMCO's No. 36 sill screed is like the No. 34, with a rounded screed point, but with drain/weep holes.

Size	Ground (G)	Steel Thickness	Flange Size	Wt./Mlf.	Length	Pcs./Bdl.	Pcs./Pallet
5 1/2"	7/8"	.019"	3-1/2"	258 lbs.	10'	10	1000

"J" METAL

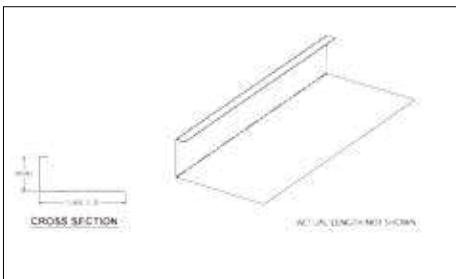

CEMCO's "J" Metal products are manufactured in various grounds (depths) to be used with a variety of polystyrene or foam insulation boards for exterior purposes. "J" Metal also provides for a workable screed around doors and windows. CEMCO's "J" Metal can also be ordered with holes and be used in some applications as a weep screed.

Gauge	Ground	Flange Size	Wt./Mlf.	Pcs./Bdl.	Bdl./Pallet
26	7/8"	7/8" S.F.	186 lbs.	10	50
26	1-3/8"	1 3/4" S.F.	220 lbs.	10	50
26	3/8"	3-1/2" L.F.	266 lbs.	10	50
26	1/2"	3-1/2" L.F.	275 lbs.	10	50
26	3/4"	3-1/2" L.F.	291 lbs.	10	50
26	7/8"	3-1/2" L.F.	299 lbs.	10	50
26	1-3/8"	3-1/2" L.F.	333 lbs.	10	50

DOUBLE "J" (#XJ-15) CONTROL JOINT

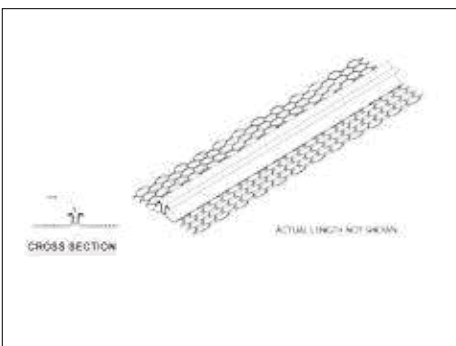

CEMCO's Double "J" (XJ-15) Control joint relieves stresses and strains in large plaster walls and ceilings. This product has expanded flanges for proper keying and easy application. Its unique design permits the plaster to key underneath the rolled edges for added adhesion while the walls expand and contract under typical conditions. The pull tape on the joint itself permits a clean finish when removed after the finish coat. CEMCO's Double "J" Control Joint is manufactured from 26 ga. , G60 hot-dipped galvanized steel by Niles and distributed by CEMCO.

Size "Y"	Pcs./Ctn.	Length	Ft./Ctn.	Wt./Ctn.	Ctn./Plt.
1/2"	24	10	240	74 lbs.	40
3/4"	24	10	240	80 lbs.	40
7/8"	24	10	240	84 lbs.	40



Steel Framing and Metal Lath

METAL LATH AND PLASTERING ACCESSORIES

DOUBLE "V" (#15) CONTROL JOINT

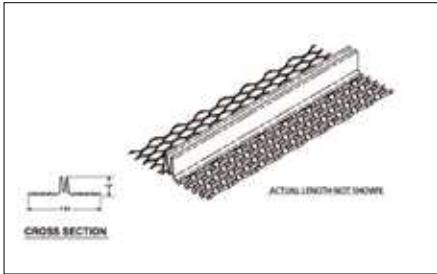

CEMCO's CEMCO's Double "V" (#15) Control joint relieves stresses and strains in large plaster walls and ceilings. This inconspicuous product provides a clean and neat joint in exterior applications. This product has expanded flanges for proper keying and easy application. CEMCO's Double "V" Control Joint is manufactured by Niles and distributed by CEMCO.

Size "V"	Pcs./Ctn.	Length	Ft./Ctn.	Wt./Ctn.	Ctn./Plt.
1/4"	24	10	240	45 lbs.	42
3/8"	24	10	240	48 lbs.	42
1/2"	24	10	240	66 lbs.	40
3/4"	24	10	240	74 lbs.	40
7/8"	24	10	240	83 lbs.	40

#30 CORNER CONTROL JOINT

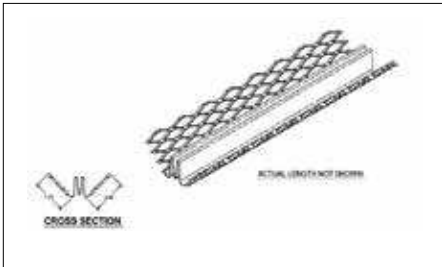

CEMCO's A Double-V expansion joint formed to a 90° for applications at inside corners. Absorbs movement due to expansion and contraction of plastered walls. Provided with an expanded flange for proper keying and easy application. #30 is manufactured from 26 ga. hot-dipped galvanized steel.

Size	Pcs./Ctn.	Length	Ft./Ctn.	Wt./Ctn.	Ctn./Plt.
1/2"	24	10	240	66 lbs.	40
3/4"	24	10	240	74 lbs.	40
7/8"	24	10	240	83 lbs.	40

#093 ZINC CONTROL JOINT

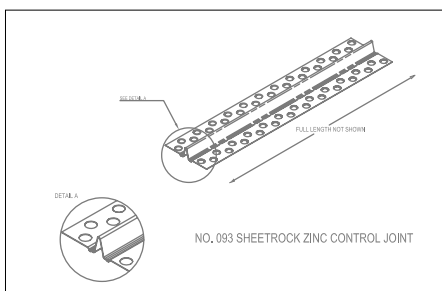

CEMCO's #093 true-zinc control joint is perfect for interior high-end plaster applications, allowing for controlled expansion of the ceiling or wall finish. Made from high quality 26 ga. zinc, and formed to exacting tolerances, the .093 bead has a tape protected expansion trough to provide for crisp and clean finishes in both plaster and veneer finishes. CEMCO's .093 control joint is manufactured by Niles Corporation.

Length	Pcs./Ctn.	Ft./Ctn.	Wt./Ctn.	Ctn./Plt.
10'	25	250	27 lbs.	20

PATCHES

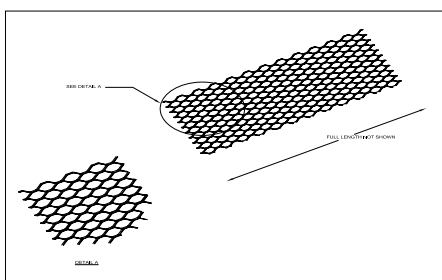

CEMCO's Patches are a recent development by CEMCO based on a timeless use of 2.5 diamond lath, but manufactured in strips or 'patches' to be used over door and window corners to greatly reduce cracking, by reinforcing stress areas. Patches can also be used as grout stop in masonry applications.

Patch Size	Pcs./Ctn.	Ctns./Pallet
6" x 18"	200	30

GO GREEN WITH CEMCO



Steel Framing and Metal Lath



For more information on USGBC and LEED Certification, logon to:

www.cemcosteel.com

California Expanded Metal Products Co. is proud to be a member of the U.S. Green Building Council and support its LEED Program, which aims to improve environmental and economic performance of commercial and residential buildings.

LEED (Leadership in Energy & Environmental Design) certifies buildings that meet the standards utilizing energy, environmental design and products, as defined in the LEED rating system. The use of Cemco products can help projects accumulate points in specific categories, including Recycled Content and Local/Regional Materials.

RECYCLED CONTENT

Recycled steel content used in the fabrication of CEMCO cold-formed-steel products are in compliance with the Requirement for Environmental and Recycled Content Materials. CEMCO steel suppliers have indicated that their steel contains 30% to 35% recycled steel. The steel products are manufactured from steel consisting of the following contents.

- 36.9% Recycled Steel
- 19.8% Post-Consumer
- 14.4% Pre-Consumer

LOCAL/REGIONAL MATERIALS

CEMCO serves the Western United States through its primary locations in the City of Industry and Pittsburg, Calif., Denver, Colo. and Ft. Worth, TX.



Steel Framing and Metal Lath

800.775.2362

WWW.CEMCOSTEEL.COM

Corporate Headquarters & Main Manufacturing Facility

263 North Covina Lane
City of Industry, CA 91744

Phone: 800.775.2362
Fax: 626.330.7598

Northern California Manufacturing Facility

1001-A Pittsburg Antioch Hwy
Pittsburg, CA 94565

Phone: 925.473.9340
Fax: 925.473.9341

Denver Colorado Manufacturing Facility

490 Osage Street
Denver, CO 80204

Phone: 303.572.3626
Fax: 303.572.3627

Ft. Worth Manufacturing Facility

8600 Will Rogers Boulevard
Fort Worth, TX 76140

Phone: 817.568.1525
Fax: 817.568.2759