

DDA Fire Block

US Patent #8,595,999

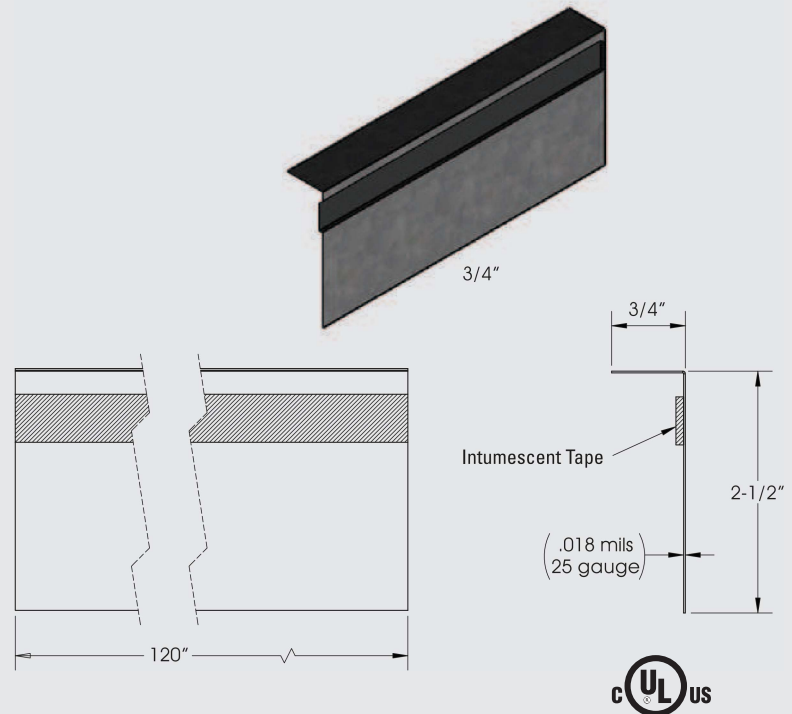

Fire Block

The Most Efficient Method in Firestopping

Contractor Preferred, Architect Specified

The DDA Fire Block is a fire-rated accessory that when combined with slotted leg, deep leg or J-Runner track will offer up to 2" unencumbered movement at the head-of-wall joint in accordance with UL-2079 "Test for Fire Resistance of Building Joint Systems". The 2-1/2" outside leg is red and marked with the proper UL identification. The section is fabricated from both minimum 0.018-inch thick hot-dipped red galvanized steel complying with ASTM A653 having minimum G-40 coating and intumescent tape.

Code Compliance

DDA not only meets all current building code deflection requirements but it can also provide fire, smoke and sound protection for drift and lateral movement. DDA is the first of its kind to provide unencumbered movement in both vertical deflection and lateral drift movement in a joint system that utilizes fire spray over mineral wool on just one side of the wall.

DDA has no restrictions providing 100% unencumbered movement. DDA has been tested for compliance with Section 713.3 of the 2012/2015 IBC and 2010/2013 CBC and is listed with UL Underwriters Laboratories in accordance with:

- UL 2079: Tests for Fire Resistance of Building Joint Systems.
- ASTM E 1966: Standard Test Method of Fire Tests of Firestop Systems.
- ULC S115-M95: Standard Method of Fire Tests of Firestop Systems.
- ICC-ES ESR-2012
- ASTM E-119 Standard Test Methods for Fire Tests of Building Construction and Materials.
- Sound Tested in Accordance with ASTM E90-09.
- For complete list of all UL joint systems visit cemcosteel.com

Seismic Requirements

DDA is approved for Class III cycling requirements, 500 cycles at 30 cycles per minute, meeting, seismic building codes requirements. The Class III movement provides design advantages over mastic reliant systems which are typically limited to Class II (wind sway) capabilities of 500 cycles at 10 cycles per minute.

Air Leakage Rating

Air leakage tests conducted for compliance with Section 713.6 of the 2012/2015 IBC and 2010/2013 CBC are witnessed by UL on conditions using DDA as the joint treatment established L-Ratings of less than 1 CFM per lineal foot. Any rating below 1 CFM is also considered the best possible L-Rating.