

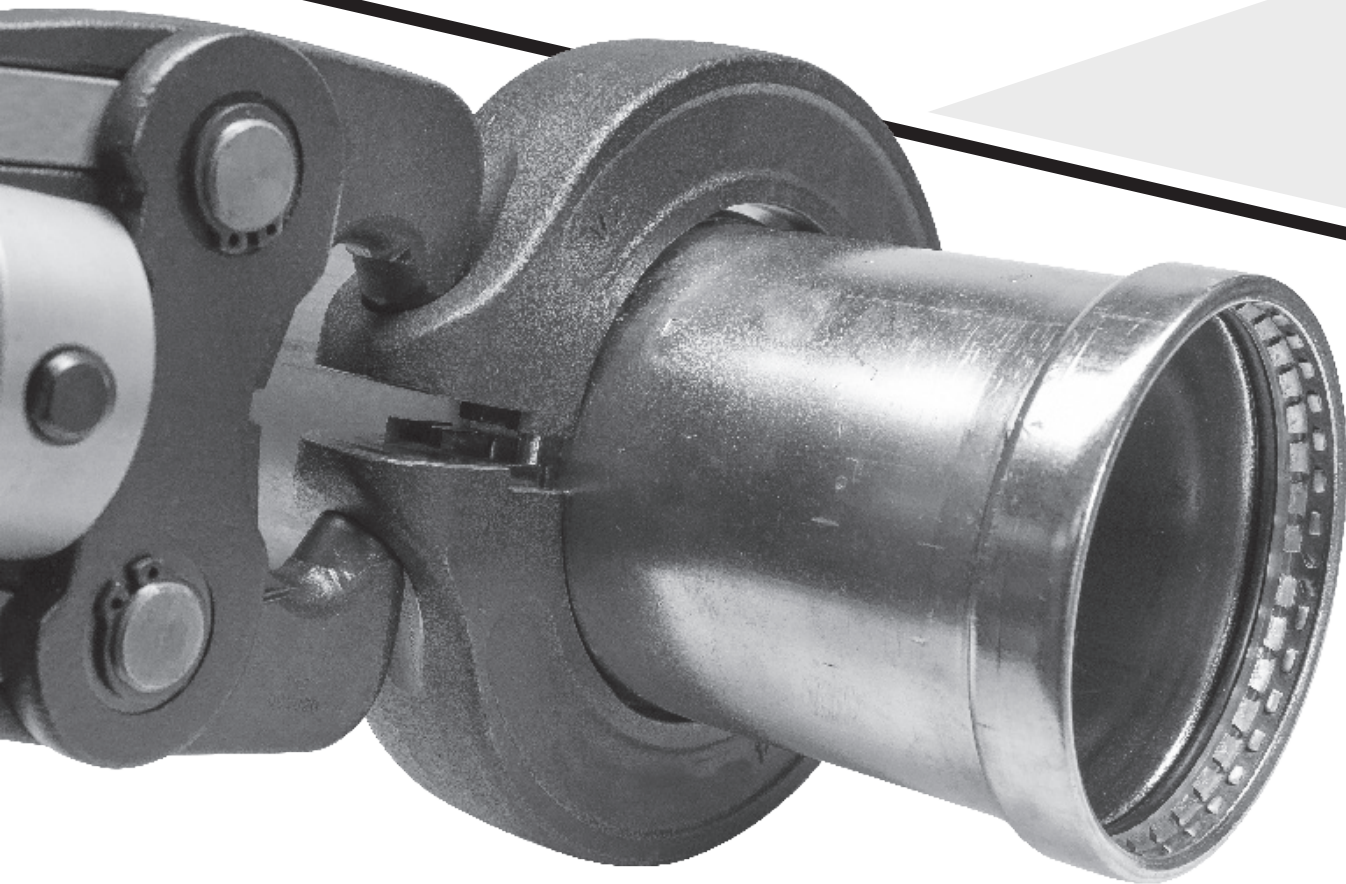

INSTALLATION MANUAL

COPPER PRESS PLUMBING FITTINGS



CerroPress® is a registered trademark of
Cerro Flow Products, LLC® 3000 Mississippi Ave. Sauget IL 62206
(618)337-6000 | techservice@cerroflow.com

Version CP_260122

CONTENTS

**ABOUT CERRO FLOW PRODUCTS LLC® AND DESCRIPTION OF CERROPRESS®
“PRESS-TO-CONNECT” COPPER & ZERO LEAD BRASS PLUMBING FITTINGS..... 3**

CERROPRESS® SYSTEMS APPLICATIONS..... 6

CERROPRESS® LISTINGS AND CERTIFICATIONS / CODES AND STANDARDS .. 7

COMPATIBILITY WITH TUBE & TOOL 9

TRANSPORTATION AND MATERIAL INSPECTION 10

SITE CONDITIONS AND STORAGE REQUIREMENTS 10

INSTALLATION REQUIREMENTS 11

QUALITY CONTROL AND PRESSURE TESTING..... 18

LIMITED WARRANTY 19

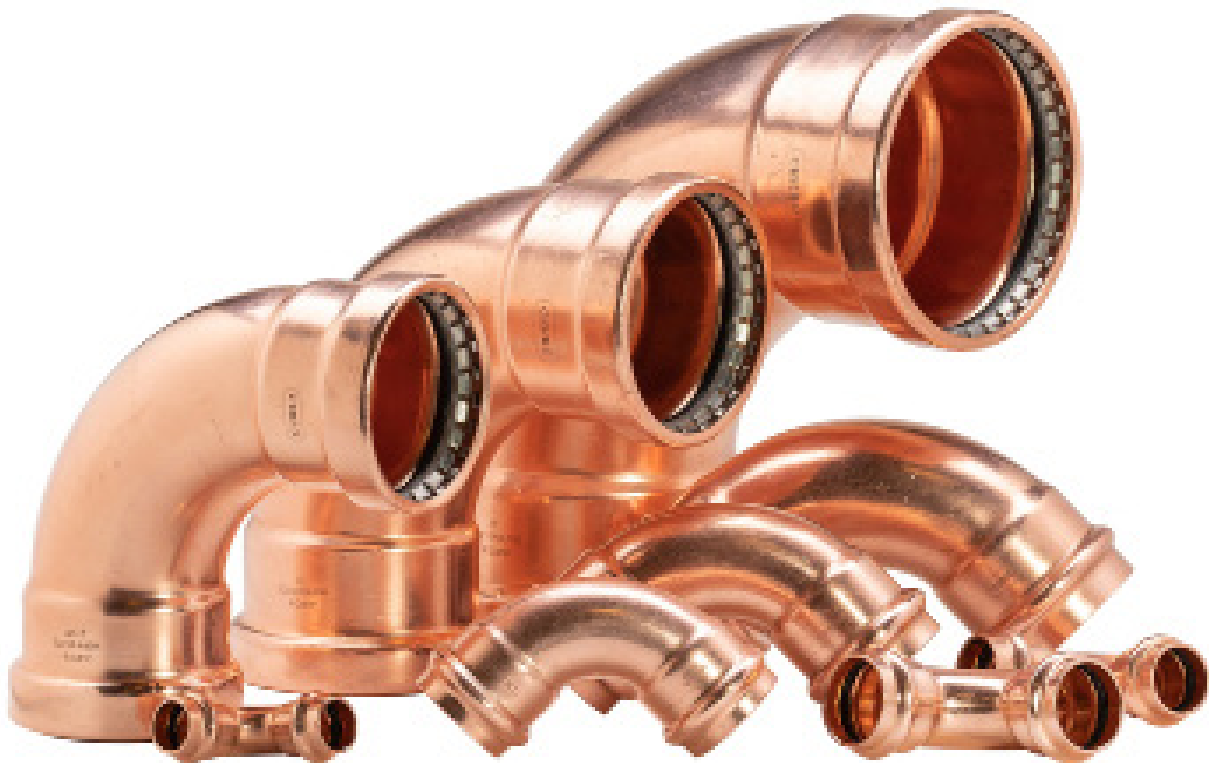

1: ABOUT CERRO FLOW PRODUCTS LLC®:

Cerro Flow Products LLC® is a world-class copper tube manufacturer providing the plumbing, HVAC, refrigeration, and industrial markets. We are known for superior product quality, unparalleled customer service, and expert technical support. Cerro Flow Products LLC has been producing “Made in America” copper tubing in Sauget IL, USA, across the Mississippi River from the St Louis Arch, for nearly 80 years.

CerroPress® press-to-connect fittings are now available for contractors preferring flameless, mechanical press joining. More professionals each day are choosing to join ASTM B88 seamless copper water tube (K, L, & M) copper tubing with press fitting technology. CerroTube™ can now be connected with CerroPress® fittings to create a system which is fast and economical while building on the reliable, proud tradition and reputation of Cerro Flow Products LLC®.

Cerro’s wrought copper press fittings are 99.9% copper which means they are endlessly recyclable and thus the most environmentally friendly choice for plumbing and mechanical systems in residential, commercial and industrial markets. When installed with the correct press tools and methods, CerroPress® fittings provide confident, safe, proven, repeatable and consistent high performance. Press connections provide economy and value by saving time and labor.

CerroPress® fittings copper and zero lead bronze fittings can join copper tube sizes ranging from ½ inch to 4 inch and include couplings, elbows, tees, adapters, reducers, bushings, caps, cross-overs, unions, di-electric unions, drop-ears, and flanges.

CerroPress® fittings are compatible with most common standard available press tools. Cold working copper fittings by pressing with a tool increases temper and hardness thus improving performance to create a permanent connection.

CerroPress® press-to-connect fittings eliminate open flames from soldering sweat-to-connect fittings or brazed joints. Unlike solder joints, press-to-connect fittings require no fire watch nor hot work permits which helps improve the economy of choosing press fittings.

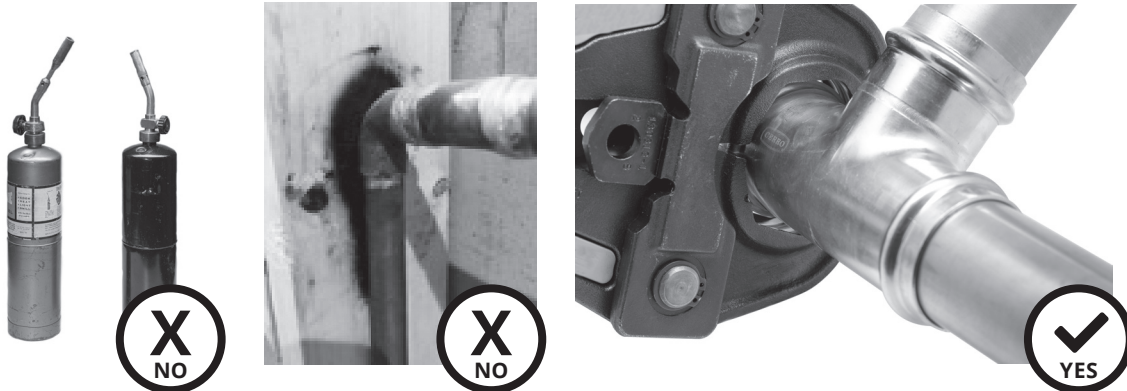

CerroPress® fittings operating parameters are:

- MAWP (maximum allowable working pressure) 200 psig
- Temperature Range of -20 deg F to +250 deg F

CERROPRESS® KEY FEATURES

- Extensive offering of over 360 SKU's with connection types of press, street, and adapters for pipe thread, PEX, and bolted flange.
- Comprehensive stock of reducing tees
- Leak detection to identify un-crimped connections during pressure testing.
- Factory installed EPDM chloramine resistant sealing element/O-Ring which is factory installed and lubricated.
- Compatible with all common tools and jaws in North America.
- Highly engineered and quality controlled to increase performance and virtually eliminate joint creep.
- For use in plumbing or mechanical applications as described.
- Designed to join ASTM B88 (Types K, L, M) hard-drawn copper tube (1/2" — 4") and soft copper tube (1/2" — 1-1/4").



Each CerroPress® fitting is marked with the following:

- Manufacturer Mark
- NSF®-61-372
- cUPC®
- Size

Domestic water treatment typically involves disinfection using chlorine and ammonia which creates chloramine. CerroPress® fittings use a chloramine-resistant high performance EPDM (Ethylene Propylene Diene Monomer) rubber compound as sealing elements (sometimes called O-Rings) which are installed at the factory. Cerro's sealing element is pre-lubricated. Additional external lubrication applied during installation is not required and may degrade the sealing element's long term performance. Cerro's sealing element has a unique profile designed for snug fit in the fitting groove to prevent displacement during tube installation. Cerro's sealing element also features technology that allows quick identification of un-pressed fittings during the system pressure testing required by your local code authority and which is good plumbing practice.



EPDM sealing element possesses excellent resistance to aging, ozone, sunlight, weathering, environmental influences, chloramine water disinfection, many alkaline and glycol solutions as listed.



The #304 stainless steel grip ring (in sizes 2.5", 3", 4") bites into the tube and securely locks the fitting. A (Polyamide) PA 6 Nylon thermoplastic separator ring (a tough, abrasion-resistant material) protects the sealing element (O-Ring) from damage during installation and pressing. The EPDM sealing element ensures water-tight connections.

Please read and understand all instructions prior to installing CerroPress® fittings to increase safety, achieve designed performance, and reduce risk of property damage. Use only in approved applications.

2: CERROPRESS® SYSTEMS APPLICATIONS

APPROVED APPLICATIONS INCLUDE: Domestic water distribution systems in residential, commercial, and industrial plumbing as described, and as verified with your local plumbing code official and AHJ.

- All tubing must comply with the ASTM B88 standard.
- Hot and Cold Potable Domestic Water
- Gray, and Drainage Water Systems
- Hydronic heating (w/ glycol)
- Condenser and Chilled water
- Water glycol mixtures of ethylene or propylene glycol up to 50% at 200° F
- Underground Facility Water

TYPE OF SERVICE	COMMENTS	PRESSURE	TEMPERATURE	COMPATIBLE WITH EPDM SEAL
FLUIDS/WATER POTABLE				
Hot and Cold Water	-	200 PSI	32° to 250° F	✓
Rainwater / Grey water	-	200 PSI	-20° to 250° F	✓
Chilled Water	Ethylene Glycol / Propylene Glycol	200 PSI	-20° to 250° F	✓
Hydronic Heating	Ethylene Glycol / Propylene Glycol	200 PSI	-20° to 250° F	✓
Cooling Water	Up to 50% Ethylene Glycol or Propylene Glycol Solution	200 PSI	-20° to 250° F	✓

NOT APPROVED APPLICATIONS INCLUDE:

The EPDM seals are not compatible with refrigerants. The pressure rating of the CerroPress® system is not sufficient for refrigerant gases.

Fluids containing hydrocarbon based oils are not compatible with EPDM sealing element (O-Rings).

Not approved for any application outside approved list.

Consult Cerro's Technical Services Department for information on applications not listed or applications outside listed temperature and pressure ranges. Techservice@cerroflow.com

3A: CERROPRESS® LISTINGS AND CERTIFICATIONS

CerroPress® fittings alloy is C12200 which is 99.9% pure copper and meets requirements of NSF/ANSI-61 and NSF/ANSI-372 lead free..

CerroPress® fittings were subjected to a wide range of performance tests including hydrostatic burst strength, dimensional tolerance, unrestrained hydrostatic pressure, dynamic torque, static torque, bending, vacuum pressure, cyclic pressure, vibration, and thermo-cycling to comply with requirements of IAPMO PS-117 and ASME B16.51

BELOW: Example burst pressure test well exceeded 600 psi yielding a 3X safety factor for 200psig MAWP.



CerroPress® fittings are certified to the following standards:

IAPMO PS-117: Press and Nail Connections

NSF/ANSI 61: Drinking Water System Components – Health Effects

NSF/ANSI 372: Drinking Water System Components – Lead Content*

*Zero Lead identifies products meeting the lead-free requirements of NSF 61 through testing per NSF/ANSI 372 (0.25% or less maximum weighted average lead content).



3B: CODES AND STANDARDS

CerroPress® fittings comply with the following codes and standards:

ASME B16.51: Copper and Copper Alloy Press-Connect Pressure Fittings

ASME B31: Code for Pressure Piping

ASTM B88: Standard Specification for Seamless Copper Water Tube

IAPMO California Plumbing Code (CPC)

IAPMO National Standard Plumbing Code (NSPC)

IAPMO Uniform Mechanical Code (UMC)

IAPMO Uniform Plumbing Code (UPC)

ICC International Mechanical Code (IMC)



ICC International Plumbing Code (IPC)
ICC International Residential Code (IRC)
National Building Code of Canada (NBCC)
National Plumbing Code of Canada (NPCC)

3C: SYSTEM DESIGN REQUIREMENTS OF PRESS FITTINGS:

Thermal expansion in installed systems generates stress on tubing and appliance connectors. Compensation must be allowed for expansion and contraction that may occur within the tubing. Expansion joints or mechanical expansion compensators may be used to alleviate these stresses. CerroPress® systems do not require any additional protection when compared to a soldered system.

The following methods of thermal compensation are effective:

- Fixed and sliding hangers
- Expansion equalization joints (expansion bends)
- Expansion compensators

CerroPress® fittings with copper tubing are approved for underground installations and must meet all state and local codes, including those for underground. Obtain written approval prior to installation from the AHJ (Authority Having Jurisdiction).

“Copper water tubing has an outstanding history of corrosion resistance in most underground environments. Copper does not naturally corrode in most clays, chalks, loams, sands, and gravels. Certain aggressive soil conditions, however, can cause it to corrode.” Copper Development Association Inc.

Protect underground piping from corrosion in a manner approved by local codes. Properly size piping to minimize risk of erosion corrosion from excessive velocities.

CerroPress® fittings are approved for use in concealed spaces. As with all water supply and drainage systems, protect concealed fittings and tubing from puncture threats.

Protect copper water supply and drainage systems from ionic and cathodic corrosion due to mixing with other metals. When two or more different metals come into contact in an electrolyte (water), one metal (that’s more reactive) acts as anode and the other (that’s less reactive) acts as a cathode. The electro-potential difference between the reactions at the two electrodes is the driving force for an accelerated attack on the anode metal, which dissolves into the electrolyte; like a battery. This is commonly known as galvanic corrosion or bi-metallic corrosion or dissimilar metal corrosion.

To minimize risk of galvanic corrosion use CerroPress® di-electric unions when connecting copper to steel or galvanized steel pipe. Do not install copper tubing directly upstream from galvanized steel pipe. Select hangers that are galvanically compatible or insulated from copper tubing. Protect copper from corrosion due to nitrites, ammonium and all corrosive chemicals.

Design CerroPress® fittings to be sufficiently isolated from mechanical vibration and transient pressure defined as pressure that surges rapid accelerations into a water distribution system. The maximum operating pressure of CerroPress® fittings is 200 psi including pressure transients.

When pressed, CerroPress® fittings comply with Uniform Plumbing Code for electrical bonding. The mechanical pressing process ensures continuous metal-to-metal contact between the tube and fitting. Verify electrical bonding using plumbing system with your local AHJ.

4: COMPATIBILITY WITH TUBE & TOOLS

Copper and copper alloy fittings are compatible with ½ inch to 1¼ inch soft copper tubing and ½ inch to 4 inch hard copper tubing types K, L, and M. All copper tubing must comply with ASTM B88 standards.

REQUIRED TOOL LIST

- Pipe cutter or a fine-toothed hacksaw
- Scratch pad or fine sandpaper
- Deburring tool
- Permanent marker for marking insertion depth on tube
- Press machine tool
- Proper press jaw and actuator for each tube diameter.

TOOL & JAW COMPATIBILITY

The tools and jaws listed below are compatible when operated per instructions provided by the tool and jaw manufacturer.

Fitting Size 1/2" — 2"

Milwaukee M12 Tool w/Compact Jaws	1/2" — 1-1/4"
Milwaukee M18 Tool w/Standard Jaws	1/2" — 2"
REMS Mini Tool w/Mini Jaws	1/2" — 1-1/4"
REMS Standard Tools w/Standard Jaws	1/2" — 2"
Ridgid Compact Tools w/Compact Jaws	1/2" — 1-1/4"
Ridgid Standard Tools w/Standard Jaws	1/2" — 2"
Rothenberger Compact Tool w/Compact Jaws	1/2" — 1"
Rothenberger Standard Tools w/Standard Jaws	1/2" — 2"
Stanley Virax Standard Tools w/Standard Jaws	1/2" — 2"

Fitting Size 2-1/2" — 4"

Milwaukee M18 Tools w/Rings & Ring Jaw
REMS Standard Tools w/Rings & Z5 Adapter Tong
Ridgid Standard Tools w/ Rings & V2 Actuator Jaw

Follow press tool manufacturer's instructions for best practice and required periodic maintenance and calibration of both the tool and jaws. Failure to do so may cause improper pressing of fittings.

5: TRANSPORTATION AND MATERIAL INSPECTION

Prior to installation, inspect plumbing system components and tubing to ensure they are free from contaminants which would degrade performance of the connections. Visually inspect sealing elements (O-Rings). In CerroPress® XL fittings inspect separator rings, and stainless steel grip rings to ensure components are intact, un-damaged and properly located within the fitting.

When transporting fittings and tube, secure load to prevent shifting and damage. Protect all components from scratches, dents, and marring. When furnished, do not remove the protective cap on fittings or tube ends until immediately prior to installation. If components are damaged during transportation, do not attempt to repair the damaged parts. Reject the damaged parts and replace with new parts.

6: SITE CONDITIONS AND STORAGE REQUIREMENTS

Carefully handle tubing and fittings during shipment and unload with reasonable care. Store fittings, tubing, and system components in a clean and dry place. Do not store components directly on the floor. Protect the stored product from moisture and dirt. Provide at least three points of support for the storage of tubing. Store different tubing sizes separately. Separately store fittings, tubing, and system components of different metals to prevent galvanic corrosion.

CerroPress® with EPDM sealing elements can be installed in ambient temperatures down to 0° F. Tubing exposed to freezing temperatures must be protected per acceptable engineering practices, codes, and as required by your local AHJ.

CerroPress® fittings are packaged in plastic bags to keep them clean and free from debris. Handle fittings with care and open bags just prior to use, to keep clean. Prior to installation, visually inspect fittings. Do not install contaminated components.



Examples of Damaged Pipe: dents, gouges and scrapes should be cut off to expose good pipe ends.

7: INSTALLATION REQUIREMENTS

CerroPress® fittings are designed to join ASTM B88 (Types K, L, M) hard-drawn temper copper tube (1/2" to 4") and soft annealed copper tube (1/2" - 1-1/4").

ASTM B88 copper tubing may contain surface imperfections, which are specifically defined and allowed by the standard. Copper tube is handled, shipped and stored multiple times before reaching the jobsite and thus may have post-manufacturing scratches or deformations. Do not install fittings over tube defects.

To support water system, plan proper fixed and sliding mounting points or hangars to allow expansion. At no point should the fitting be supporting the tubing by itself. All tubing coming off fittings should be independently supported. Hangers and supports must conform to the AHJ and local code requirements. Hangers and supports should comply with the ANSI/MSS SP 58 Standard for Pipe Hangers and Supports - Materials, Design, Manufacture, Selection, Application and Installation.

REQUIREMENTS FOR ADAPTERS, FLANGES, STREET, AND BUSH ADAPTERS



When using a threaded adapter to press connection type of fitting, always install the threaded connection first and press connection second to avoid torsion on the press fitting.



When using bolted flange type connections, bolt the flange end in place prior to pressing the connection to tube.



When using street fittings and bushing adapters, Cerro recommends using press connections to join the street or bushing. Should soldering of the street or bushing connection be unavoidable, prior to soldering, remove the press end EPDM Sealing Element (O-Ring). Solder the standard wrot connection first prior to the press connection. Allow the fitting to cool, re-insert the EPDM Sealing Element (O-Ring), and then press the connection. Pressing near soldered connections has potential to fail due to mechanical deformation of fitting and tube. Avoid whenever possible and pressure test when complete.

MAINTAIN MINIMUM DISTANCE BETWEEN PRESS FITTINGS.

Mechanical pressing causes some deformity of the tubing. To prevent leaks, maintain minimum distance between fittings as indicated in table below:

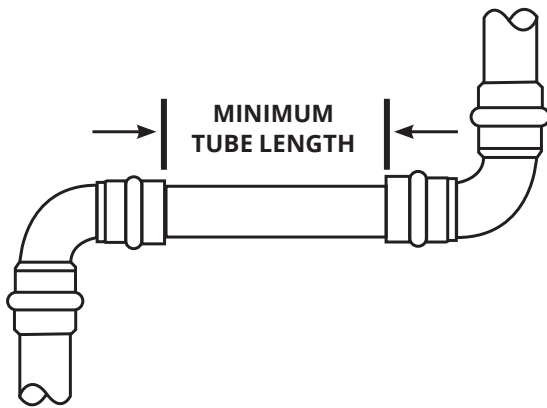

MINIMUM DISTANCE BETWEEN CERROPRESS®	
TUBE DIAMETER	TUBE LENGTH
NOMINAL INCH	INCH
1/2"	1"
3/4"	1-1/2"
1"	2"
1-1/4"	2-1/2"
1-1/2"	3"
2"	4"
2-1/2"	5"
3"	6"
4"	8"

PRESSING NEAR AN EXISTING SOLDERED OR BRAZED CONNECTION

Maintain minimum distance when pressing connections near an existing solder or brazed joint of two pipe diameters. Ensure tube is free of residual solder or other debris prior to installing CerroPress® fittings.

Ideally solder and brazed fittings are prefabricated prior to installing the press fitting. Should brazing or soldering be required near an existing press connection, maintain a minimum distance to prevent damage to the sealing element (O-Ring). The installer should take precautions to keep the press connection cool by wrapping the connection with a cold wet rag.

When soldering near an existing CerroPress® connection, stay a minimum of 12 inches away.

When brazing near an existing CerroPress® connection, stay a minimum of 36 inches away.

STEPS FOR PROPER INSTALLATION OF PRESS FITTINGS



Check sealing element (O-Ring) is well seated in groove and hasn't been dislodged or damaged

Check that the fitting end is not bent or damaged and is perfectly round.

Check to ensure the sealing element (O-Ring) is free of field applied oil or grease.

Do not use any petroleum-based lubricants. Oil-based lubricants, dirt and debris may damage the seal. A contaminated seal can lead to leaks and extensive property damage.

Water is the only acceptable lubricant to be field applied.



Cut copper tubing at a square right angle using displacement type cutter or fine-toothed steel saw. Do not secure tube in vice close to cut line. Do not cut through grooves, scratches, manufacture marks, nor engravings. Do not use flame cutting nor cutting oils. Inspect tube for out-of-round defect at cut.



Deburr inside and outside of the tube. Tube can be damaged by improper deburring tools. Connections may leak if damaged by improper deburring. Burrs can damage the sealing element (O-Ring) and may cause leaks. A smooth transition chamfer is recommended to ease tube insertion past the seal.



Use a wire brush, nylon scratch pad, sand cloth, or fine sandpaper to remove loose dirt and oxidation from the pressing area. This will make evident any defects in the tube such as scratches, which are a leak path. While the press fitting will perform well over oxidized copper, removing the oxidation exposes defects and so it is recommended practice.

Installers should recognize surface scratches and deep incise marks (identification stamping) on the tube and avoid placing sealing element (O-Rings) directly over surface irregularities to reduce the risk of leaks. Sanding and cleaning the surface may not be sufficient to remove defects which may cause a leak path.

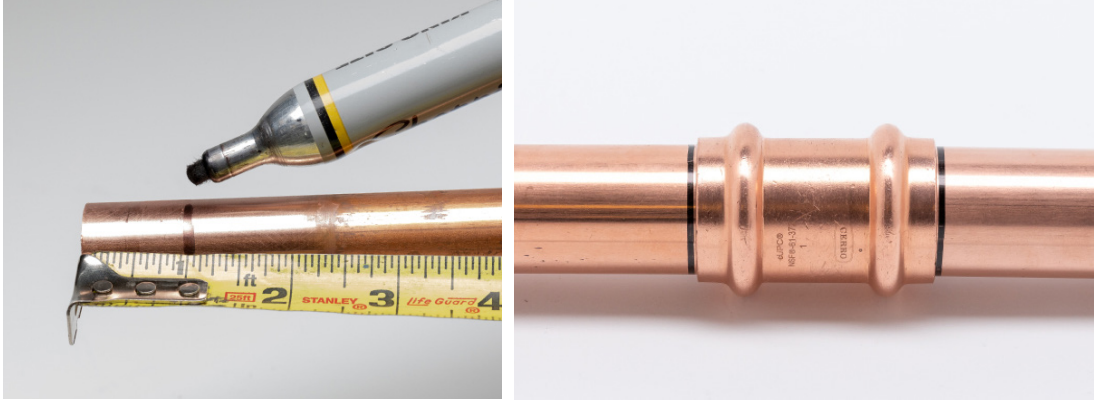

Mark proper insertion depth on the tube with a permanent marker prior to assembly. Insertion depths are as indicated by the CerroPress® Insertion Depth Chart. Improper insertion depth may result in improper seal.

CERROPRESS® INSERTION DEPTH CHART									
Tube Size	1/2"	3/4"	1"	1-1/4"	1-1/2"	2"	2-1/2"	3"	4"
Insertion Depth	3/4" (0.748")	7/8" (0.886")	7/8" (0.886")	1-1/16" (1.083")	1-7/16" (1.398")	1-9/16" (1.555")	1-11/16" (1.673")	1-15/18" (1.949")	2-3/8" (2.343")

While turning slightly, slide press fitting onto tubing to the marked depth and until fully seated on stop. Ensure tube is inserted to the proper depth. Failure to do so may result in an improper seal.



No-stop couplings and no-stop extended couplings are used primarily to make repairs. No-stop couplings slide completely onto a tube. Unlike fittings with a stop, non-stop couplings have both minimum and maximum allowable insertion depths. Both minimum and the maximum insertion depths must be marked and a line connecting the two marks.

Select the proper size of the appropriate pressing jaw.



Pull retaining pin out of press tool and insert appropriate jaw. Push jaw set retaining pin back in until it locks the jaw in place. The tool will not work unless the pin is fully engaged. Select the jaw set that corresponds to the size of the joint to be crimped and insert the jaws into the pressing tool.



Use CerroPress® compatible press tool and jaws. Place press tool over the fitting at the bead to be pressed. Most pressing tools on the market can be used, but always refer to the Tool & Jaw Compatibility Chart.

Ensure the tube is completely inserted to the fitting stop (appropriate depth) and in-line with the fitting prior to applying the pressing jaws onto the fitting.



Squeeze jaw arms to open and place at right angle on the fitting. Look at insertion depth mark on the tube to make sure that the tube is still properly inserted into the fitting. Ensure that the contour of the jaws is properly aligned with the contour of the fitting groove.

Place the pressing jaw over the groove on the fitting and ensure the tool and jaws are at a 90° angle (perpendicular) to the centerline of the tube. Depress the pressing tool trigger to begin the pressing cycle.

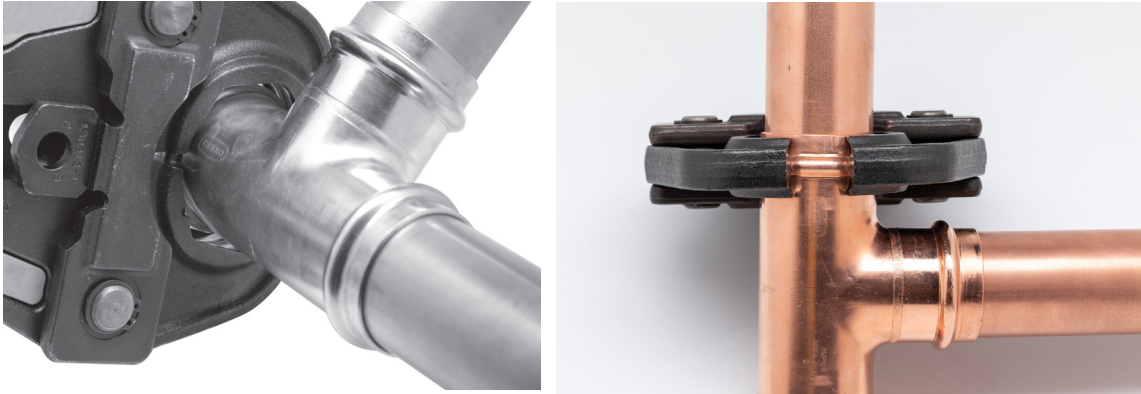

Follow tool manufacturer's instructions for proper use, maintenance and service of press tool.

With the pressing tool perpendicular to the tube, begin the pressing cycle by pulling the trigger of the pressing tool. Hold the trigger continuously until the tool has made a complete press cycle.

WARNING! Keep extremities and interferences away from press tool during tool operation to prevent injury and incomplete press.

When pressing cycle is complete, press the jaw arms to open the jaw and remove the pressing tool and jaw from the fitting.



Inspect the crimped fitting to ensure proper crimp and check the connection for the following problems:

- Misaligned tube not parallel with fitting.
- Tube not fully inserted. Check insertion depth marks. Ensure the tube has remained fully inserted, as evidenced by the visible insertion mark.
- Jaw mis-alignment with the fitting groove profile.

If problems are found, cut out and replace with new tubing and a new fitting.

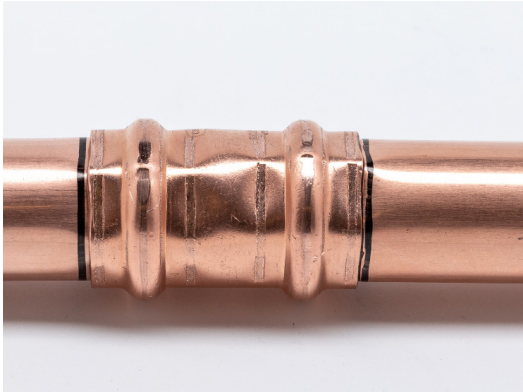

The pressing process can cause deflection (angular misalignment) to occur. The fitting may deflect toward the opening of the jaw or ring. Deflection can be minimized by alternating the attack angle of the tool on either end of the fitting.

FOR LARGE DIAMETER XL FITTINGS, USE ACTUATOR



8: QUALITY CONTROL AND PRESSURE TESTING

CerroPress® sealing element (O-Ring) is designed with a leak detection feature so installers can identify un-pressed connections during the air or water pressure test. The uniquely designed EPDM sealing element (O-Ring) allows fluids or gases to flow past the seal and leak when the fitting has not yet been pressed. When the fitting has been pressed, the sealing element (O-Ring) will create a water and air tight seal around the tube.

Cerro recommends the following leak pressure test of installed water system in accordance with local codes, the AHJ, and project specifications in order to locate any un-pressed fittings.

WATER TESTING:

Use potable water for testing. When the system, or portion of the system, is installed and isolated, pressurize to 15 PSI minimum to 50 PSI maximum. If an un-pressed fitting is found, make sure the tube is fully inserted before completing the press.



The system should stabilize over the next several hours (3 hour minimum or per AHJ) Monitor pressure with a pressure gauge. If after the allotted time, the pressure has dropped, add more pressure to bring the system back up to the desired initial test level. Allow another 3 hours for complete system stabilization. If upon inspection the system pressure has dropped below the test level, there is likely an un-pressed fitting leaking. Leaks are easily identified by leaking water.

Again, if an un-pressed fitting is found, make sure the tube is fully inserted before completing the press. Once any un-pressed connection has been tested and repaired, repeat the testing process until 50 PSI pressure is maintained for 24 hours or for the duration of time and pressure specified by local AHJ.

Once the initial test is successful, and confirmed to be leak-free, the system may be pressure tested up to 600 psi maximum. Then reduce to working pressure design of the system, not to exceed 200 psi maximum.

AIR TESTING:

Testing with air can be dangerous at high pressures. Air testing performed with dry clean oil-free air, carbon dioxide or nitrogen charge to an initial range of ½ PSI minimum to 45 PSI maximum and in compliance with your local AHJ. If an un-pressed fitting is found, make sure the tube is fully inserted before completing the press.

The system should stabilize over the next several hours (3 hour minimum or per AHJ) Monitor pressure with a pressure gauge. If after the allotted time, the pressure has dropped, add more pressure to bring the system back up to the desired initial test level. Allow another 3 hours for complete system stabilization. If upon inspection the system pressure has dropped below the test level, there is likely an un-pressed fitting leaking.

Leaks can be found by using a commercial leak test solution or soap and water mixture, which will form bubbles identifying an un-pressed leak point. If an un-pressed fitting is found, make sure the tube is fully inserted before completing the press. Once any un-pressed connection has been tested and repaired, repeat the testing process until initial test pressure is maintained for 24 hours or for the duration of time and pressure specified by local AHJ.

Once the system has been confirmed to be leak free, pressure can be increased to the recommended working pressure to verify system integrity not to exceed 200 psi.

9: LIMITED WARRANTY

LIMITED WARRANTY - CerroPress® by Cerro Flow Products LLC®

Unless otherwise provided by Cerro Flow Products LLC (Cerro) in writing, Cerro warrants that its CerroPress® fittings will be free from defects in material and workmanship for a period of 50 years after shipment when installed in accordance with the CerroPress® installation instructions using Cerro approved tools and jaws.

THESE ARE CERRO'S ONLY WARRANTIES. CERRO DISCLAIMS ALL OTHER EXPRESS OR IMPLIED WARRANTIES, INCLUDING, WITHOUT LIMITATION, THE IMPLIED WARRANTIES OF MERCHANTABILITY, NON-INFRINGEMENT AND FITNESS FOR A PARTICULAR PURPOSE.



If during the warranty period, Buyer notifies Cerro in writing that any products are not in conformity with the warranty and Cerro agrees, after inspection (at its option), then Cerro will repair, replace or refund the total amount received by Cerro therefore, at its sole option, provided Buyer returns such products to Cerro for inspection.

This shall be Buyer's exclusive remedy for Cerro's liability. Any claims not made during the warranty period are deemed waived. Any contract created between Cerro and Buyer is subject to the specific conditions that (a) Cerro is not obligated to provide insurance or indemnify Buyer, and (b) there are no flow-downs from any person or entity, including the federal government, that become part of the contract.

The forgoing warranties only cover copper to copper use and do not cover reimbursement for labor, transportation, removal, installation, de-installation or other expenses which may be incurred in connection with the return, repair or replacement or warranty claims. In no event shall Cerro be liable for any incidental, special, punitive, or consequential damages or lost profits of any kind or nature whatsoever resulting from the product or product performance.

**CerroPress® is a registered trademark of
Cerro Flow Products, LLC® 3000 Mississippi Ave. Sauget IL 62206
(618)337-6000 | techservice@cerroflow.com**