

# ACOUSTICAL DESIGN FOR OPEN SPACES

Creative  
Alternatives  
to Suspended  
Ceilings





# Creative freedom and acoustic control – no grid required



The design opportunities presented by modern open spaces create a unique set of challenges when it comes to acoustics. Influences as diverse as the creative reuse of factories to the benefits of daylighting have contributed to the popularity of open plenums, exposed structures and the use of glass, wood, metal, polished concrete and other acoustically reflective materials.

A wall-to-wall suspended ceiling may be the most effective acoustic solution, but it's not always an option – for structural reasons as well as design preferences. In adaptive reuse or renovation situations, acoustic solutions often have to accommodate existing HVAC ductwork, plumbing and fire protection systems.

When design dreams and structural realities demand a creative alternative, CertainTeed Architectural has the sound-absorbing clouds, baffles, direct-to-deck panels and wall panels you need to elevate your designs with outstanding acoustic control.

**And our Technical Services team provides the advice to ensure you get the right ceiling for the space.**







# Acoustic fundamentals for open spaces



The primary acoustic concern in open spaces is reverberation time (RT) – the time it takes for the sound to die off after the source has stopped.

RT is directly impacted by the surface area of sound-absorbing materials in the space. However, properly placed clouds and baffles can absorb a significant amount of sound with less surface area than suspended ceilings because they absorb sound from both sides.

### WHAT IS THE RIGHT REVERBERATION TIME FOR A SPACE?

It depends on the purpose of the space.

If the goal is to maximize speech intelligibility – essential for classrooms and office environments

– the RT should last less than 1 second. Acoustic ceiling and wall treatments (including clouds, baffles and suspended ceilings) and other acoustically absorptive materials like upholstered furniture, carpet and curtains will shorten RT. Larger room volume will also contribute to shorter RT.

Some areas require a livelier, more energetic sound environment. Restaurants and other social spaces are most comfortable with RT of between 1.4 and 2 seconds. Smaller rooms and acoustically reflective surfaces (glass, drywall, brick, concrete, hard surface flooring, etc.) lead to longer RT. But even energetic spaces require some sound absorption to strike the balance between comfortably lively and just plain loud.

### HOW MUCH ACOUSTIC IMPROVEMENT CAN I EXPECT FROM EACH PRODUCT?

It depends on the amount of coverage. The chart below compares a wall-to-wall ceiling with various alternatives – including no ceiling at all.

	EXPOSED STRUCTURE: NO CEILING	ECOPHON® SOLO™ CLOUDS 60% COVERAGE	ECOPHON® SOLO™ BAFFLES 30% COVERAGE	ECOPHON® FOCUS™ B, F, SQ DIRECT-TO-DECK	WALL-TO-WALL SUSPENDED CEILING
Material required: 1,000 sq. ft. space w/12 ft. ceiling height (12,000 FT <sup>3</sup> )	-	40 Solo Squares (≈ 620 sq. ft.)	40 Solo Squares (≈ 310 sq. ft.)	250 Focus SQ/600mm (≈ 1,000 sq. ft.)	125 Symphony f 2 ft. x 4 ft. panels (≈ 1,000 sq. ft.)
RT (reverberation time)	3.2 sec	0.54 sec	1.25 sec	0.66 sec	0.45 sec
Adjusted RT w/addition of 8 panels (2 ctn.) Ecophon Akusto Wall Panel C	1.85 sec	-	0.98 sec	-	-



## DIVING INTO DESIGN WITH CLOUDS, BAFFLES AND MORE

The following pages outline key considerations for designing with clouds, baffles, direct-to-deck panels and wall panels, including coverage, placement and quantities. The goal is to jump-start your creativity and give you a basic idea of what you might need for a given project.

## READY TO FINE TUNE YOUR DESIGN AND MAXIMIZE ACOUSTIC PERFORMANCE?

To learn more, contact your CertainTeed Architectural representative, call 800-233-8990 or visit [CertainTeed.com/AcousticalDesign](http://CertainTeed.com/AcousticalDesign)



# Designing with free-hanging clouds



Acoustic clouds are the ultimate tool for design freedom. Different colors, shapes and sizes give designers hundreds of options. And that's just the product itself. Consider positioning, angles, stacking and layering, and the possibilities are as open as the spaces.

Clouds can also be used with wall-to-wall ceilings to boost noise control in areas where a lot of people are speaking at the same time, such as a call center, reception area or restaurant. Adding lowered clouds directly above tables or desks dramatically reduces the overall noise level and sound propagation.

## COVERAGE AND PLACEMENT

On average, 30 - 60% coverage with Ecophon® Solo™ Clouds achieves sound absorption similar to a suspended ceiling. But placement is key to acoustic performance.

The closer to the origin of the sound, the better. In spaces where speech is the primary sound source, installing clouds in the middle of the space rather than close to the ceiling is more efficient, because they absorb sound that has bounced off the deck.

How much more efficient? A 16 square foot absorber (e.g. Solo™ Square) installed 40 inches from the ceiling absorbs 15% more sound than one installed 8 inches from the ceiling. Spacing units at least 18 inches apart also ensures better sound absorption.

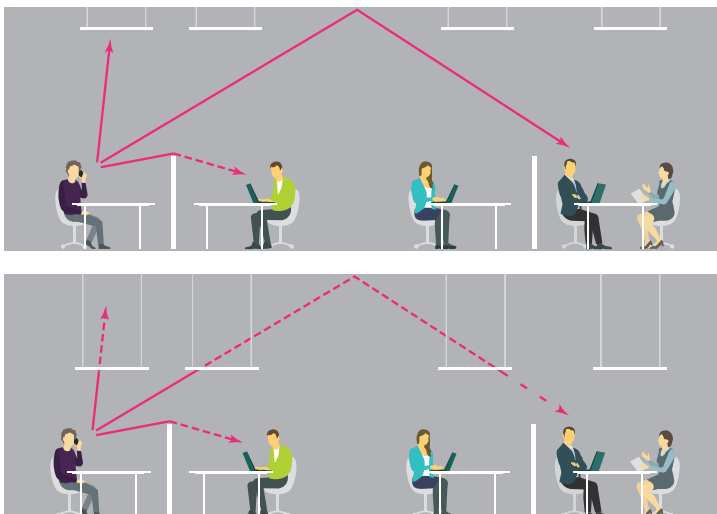





Positioning clouds toward the middle of the space allows them to absorb sound from the source as well as sound reflected from the deck above, making them more efficient than clouds installed close to the deck.

## CREATIVE APPLICATIONS

From this simple principle, you can let your creativity take over. Clouds of any shape and color can be installed in layers, on angles, at any depth you choose to create anything from minimalist acoustic control to dramatic sculptural installations.

## HOW MUCH PRODUCT DOES IT TAKE?

UNITS REQUIRED TO ACHIEVE 30 - 60% COVERAGE IN A 1,000 SQ. FT. SPACE (PANEL DIMENSIONS APPROXIMATE):

	20 - 39 units of Solo Square (≈ 4' x 4')
	10 - 20 units of Solo Rectangle (≈ 4' x 8' size)
	56 - 112 units of Solo Circle (≈ 32" diameter size)
	25 - 49 units of Solo Trapezoid (≈ 46" x 46")
	30 - 60 units of Solo Hexagon (≈ 41" x 47")

Note: There is a ratio to determine quantities for each product. The above are examples. Work with your CertainTeed Ceilings representative to determine quantities and layouts for your project.







# Ecophon® Solo™ Clouds



## COLORS, SHAPES AND SIZES TO UNLEASH YOUR CREATIVITY

- 6 standard shapes and 10 sizes
- 22 standard colors selected to reflect current color trends and customer demand
- Premium painted surface on both sides and edges is standard for a finished look from every angle

### STANDARD COLORS

WHITE	DARK DIAMOND	CLOUDY DAY	EUCALYPTUS LEAF
MOONLIGHT SKY	SCALLOP SHELL	RUBY ROCK	SUMMER FOREST
SILENT STEAM	PEACH ROSE	HIGHLAND FOG	FRESH CLOVER
GOLDEN FIELD	SILK SLATE	SILVER STONE	WET SAND
SUNSET HEAT	VOLCANIC ASH	MORNING DRIZZLE	
OCEAN STORM	GOGI BERRY	SAGE GARDEN	

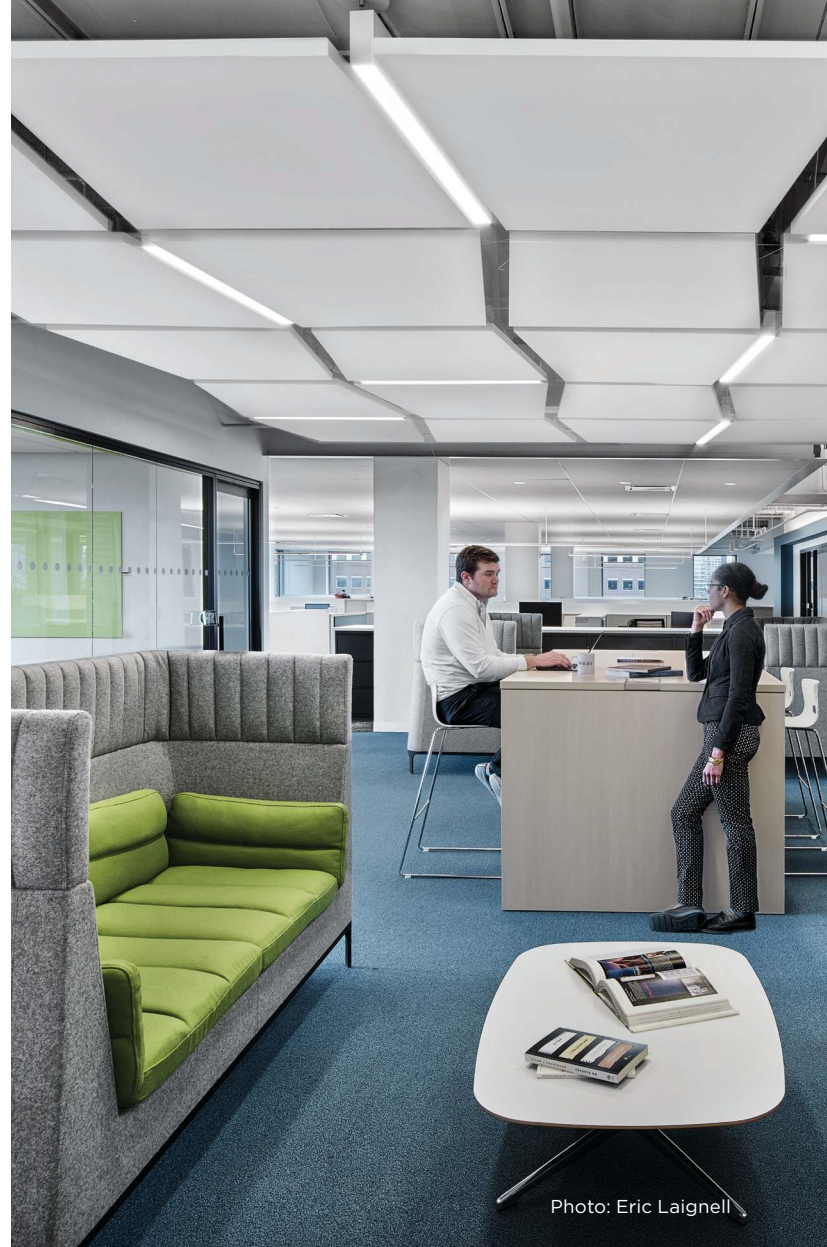
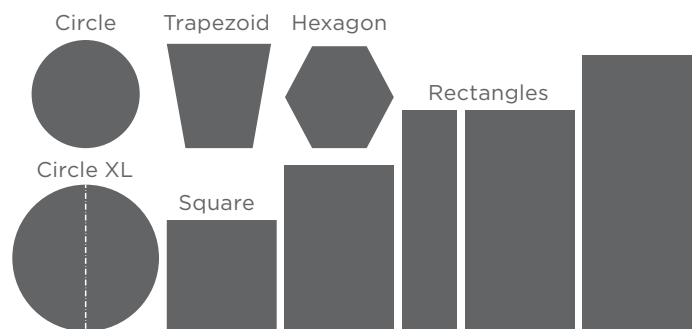

Photo: Eric Laignell

### STANDARD SHAPES



### ECOPHON SOLO FREEDOM

Solo Freedom gives you complete creative control. With Freedom, you can design virtually any custom shape — ovals, triangles, octagons and more — based on a 1200mm x 1200mm or 2400mm x 1200mm panel.





## VERSATILE INSTALLATION FOR DESIGN FLEXIBILITY

Lightweight and resilient high-density fiberglass is easy to handle, yet robust enough to be used in large panels without risk of sagging or requiring extra support.

Two suspension system options:

- Adjustable hanger wires
- Brackets

One wire can connect to and support up to four layered panels

Can be angled up to 60° for creative installations

Lighting fixtures can be installed directly in panels – no sagging or extra support\*

## CONFIGURATION SUGGESTIONS

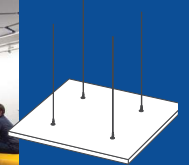

### INDIVIDUAL SUSPENSION

Individual clouds can be easily suspended using standard factory anchors and adjustable aircraft hanger wire—no special tools required—for a clean, elegant look.

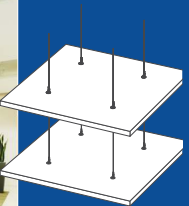

### STACKED OR LAYERED

For added depth, texture and acoustic control, hang multiple Ecophon Solo clouds in tiered layers. Included hardware and hanger wires can support up to 4 flat or 3 angled panels in one tier.

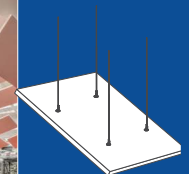

### ANGLED

To add a sense of movement to your ceiling design, or to create a sculptural point of interest that doubles as sound absorption, Ecophon Solo clouds can be suspended at varying angles up to 60°.



# Designing with baffles



Vertical baffles create a uniquely modern visual. Linear rectangles, undulating waves and cutting-edge zig zag patterns provide excellent sound absorption with a relatively shallow system depth. Ecophon Solo baffles can be suspended in atria to avoid interrupting sightlines or diminishing the magnitude of the space.

## COVERAGE AND PLACEMENT

Like clouds, the square footage of baffles should equal 30 - 60% of the ceiling square footage. Baffles also perform best when they are positioned to allow sound to move between and bounce off them.





In the case of baffles, that placement has to do with the distance between them. Sound absorption is optimized when rows or checkerboard patterns are spaced a minimum of 24 inches apart.

## CREATIVE APPLICATIONS

In large atriums and clerestory spaces, suspended baffles are an even better option than clouds, as they visually maintain the magnitude of the space without disrupting sight lines to the top of the building.

## HOW MUCH PRODUCT DOES IT TAKE?

UNITS REQUIRED TO ACHIEVE GOOD SOUND ENVIRONMENT (RT 1 SEC) IN A 20,000 CUBIC FT. SPACE (PANEL DIMENSIONS APPROXIMATE):

	250 units of Solo Baffles (≈ 8" x 48" size)
	235 units of Solo Baffles (≈ 12" x 48" size)
	115 units of Solo Baffles (≈ 24" x 48" size)
	105 units of Solo Baffles Wave (≈ 24" x 72" size)
	105 units of Solo Baffles Zig Zag (≈ 24" x 72" size)

## CREATE THESE EFFECTS WITH YOUR NEXT PROJECT

Visit [CertainTeed.com/SoloBaffle](https://www.certainteed.com/SoloBaffle), contact your CertainTeed Ceilings representative or call 800-233-8990 for design patterns using Wave and Zig Zag.





# Ecophon® Solo™ Baffles



## ELEGANT LINES IN A VARIETY OF COLORS, SHAPES AND SIZES

20 standard colors selected to reflect current color trends and customer demand (See page 8 for palette)

Premium painted surface on both sides and edges standard for a finished look from every angle

Now available in 3 shapes and 10 size options, all in one thickness (1.5" or 40mm)

Horizontal and vertical application options



## EASY INSTALLATION

Lightweight and resilient high-density fiberglass is easy to handle

Two installation options:

- Direct anchors for horizontal or vertical mounting
- Suspended hooks

Demountable for accessibility

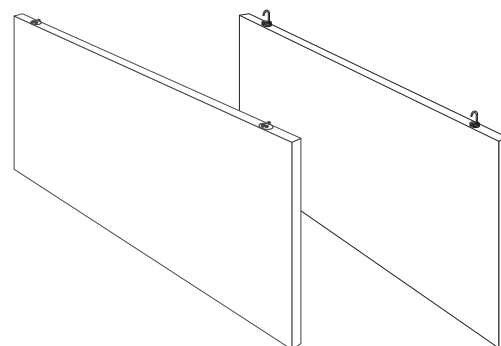

## CONFIGURATION SUGGESTIONS



### STAGGERED

Stagger wave- or zig zag-shaped baffles at varying intervals to create movement with unique angular or flowing expressions.



### ON THE WALL

Create stacked or staggered formations for unconventional visual effect on vertical surfaces using the Baffle Wall Fixing Accessory.

## STANDARD SHAPES

Rectangles



Wave



Zig Zag



# Designing with direct-to-deck panels



With the popularity of adaptive reuse projects in urban areas across the country, it is not surprising that roughly 40% of ceilings are destined for remodeling projects. Remodels, renovations and adaptive reuse projects can be especially challenging. Existing building systems may not allow for suspended ceilings and may even make the placement of clouds and baffles difficult.

Fire suppression systems in particular may dictate ceiling solutions, as they are essential to the space and reconfiguring them is cost-prohibitive. Upright sprinkler heads are one of the main reasons to use a direct-to-deck solution. These panels are also ideal for spaces with low ceilings, angled ceilings, or exposed wood or metal beams.

## COVERAGE AND PLACEMENT

Whether the panels are mounted with glue or screws, with an NRC range of 0.75 - 0.80, they have absorption levels similar to high-performance suspended ceiling panels. As a result, they should cover as much of the ceiling as possible.

## CREATIVE APPLICATIONS

When applied to the entire ceiling, direct-to-deck panels can simulate a monolithic drywall finish while providing excellent sound absorption.

Applied in fields or as individual panels, they can also be used for acoustic remediation in existing spaces like offices, retail and restaurants without causing major interruption to occupied areas.

## CHOOSING THE RIGHT PANEL FOR THE APPLICATION

THE RIGHT DIRECT-TO-DECK PANEL FOR THE SPACE DEPENDS ON THE PLACEMENT (AS INDIVIDUAL TILES, FIELDS, OR FULL COVERAGE) AND THE CONDITION OF THE ATTACHMENT SURFACE.

SYSTEM	SINGLE TILES	FIELDS	FULLY COVERING
Focus B, glue	●	●	●
Focus SQ, glue	●	●	●
Focus F, screw or glue		●*	●

ATTACHMENT SURFACE	FOCUS B	FOCUS SQ	FOCUS F
Even	●	●	●
Slightly uneven		●	●
Uneven			●**

\*Require an edge covering trim

\*\*For very uneven surfaces, attach Focus F to pre-mounted furring



# Direct-to-Deck Ecophon® Focus™ Panels

## CHOICE OF COLORS AND EDGE DETAILS

20 new standard colors selected to reflect current color trends and customer demand (See page 8 for palette)

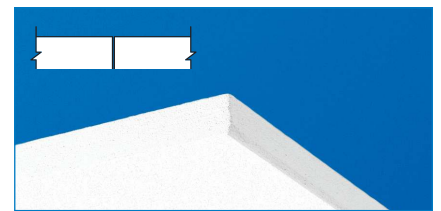

### Focus B

≈ 24" x 24" beveled edge panels

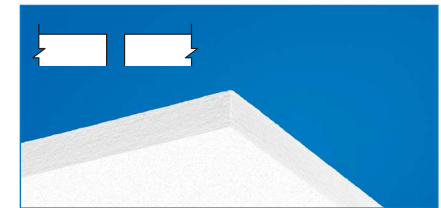

### Focus SQ

≈ 24" x 24" | ≈ 24" x 48"  
square edge panels

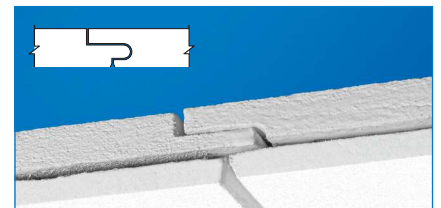

### Focus F

≈ 24" x 24" | ≈ 24" x 48"  
tongue and groove panels (available in white only)

## QUICK, CLEAN INSTALLATION

Lightweight and resilient high-density fiberglass is easy to handle

Painted, reinforced edges resist damage from handling

Choice of installation options, all of which are less labor-intensive than hanging grid and panels:

- Direct-to-deck with adhesive
- Direct-to-deck with concrete screws\*
- Indirect attachment to wood furring\*



# Designing with wall panels

You can boost the effectiveness of suspended ceilings and free-hanging units like Ecophon® Solo™ Clouds and Baffles with the addition of acoustic wall panels.

## COVERAGE AND PLACEMENT

The amount of wall panel coverage required depends on the use of the space. In educational settings, panels should be equal to 10 - 25% of the floor area. In smaller spaces such as dining rooms or conference rooms, panels equal to as little as 8 - 13% of the floor area will significantly improve speech clarity and reduce reverberation time.

Ideally, wall panels should be positioned in alignment with the sound source, and as close to it as possible. In an open plan office or classroom setting, panels should be placed at the height of a seated employee or student. Placing panels on two adjacent walls will prevent echoes between parallel reflecting walls.

## CREATIVE APPLICATIONS

Aesthetically, the latest vertical sound absorption solutions are a long way from the acoustic tack-boards of the past. Frameless panels with a smooth surface and clean painted edge are available in a variety of shapes, sizes and colors.

Wall panels are particularly helpful in reducing echoes and improving speech intelligibility in spaces with high ceilings and/or highly reflective walls.

## HOW MUCH PRODUCT DOES IT TAKE?

UNITS REQUIRED FOR A 750 SQ. FT. CLASSROOM  
(SELECT ONE SOLUTION BELOW)

<input type="checkbox"/>	19 - 47 Akusto One square panels (≈ 24" x 24")
<input type="checkbox"/>	9 - 23 Akusto One rectangle panels (≈ 48" x 24")
<input type="checkbox"/>	6 - 15 Akusto One circle panels (≈ 48" diameter)

UNITS REQUIRED FOR A 300 SQ. FT. CONFERENCE ROOM  
(SELECT ONE SOLUTION BELOW)

<input type="checkbox"/>	6 - 10 Akusto One square panels (≈ 24" x 24")
<input type="checkbox"/>	3 - 5 Akusto One rectangle panels (≈ 48" x 24")
<input type="checkbox"/>	1 - 4 Akusto One circle panels (≈ 48" diameter)

**TO LEARN MORE, CONTACT YOUR CERTAINTEED CEILINGS REPRESENTATIVE, CALL 800-233-8990 OR VISIT [CERTAINTEED.COM/ACOUSTICALDESIGN](http://CERTAINTEED.COM/ACOUSTICALDESIGN).**



# Akusto™ One Wall Panels



## COMBINE COLORS, SHAPES AND SIZES FOR CREATIVE PATTERNS

- 3 standard shapes in a range of sizes
- 18 standard colors in a smooth fabric surface
- Fully painted edges in white or gray
- Special order panels can be used to turn artwork and photography into decorative acoustic panels. Contact your sales representative for more details.



## STANDARD COLORS

ACAI	CRANBERRY	GINGER	GARLIC
THYME	PEPPER	TANGERINE	LICORICE
MUSTARD	MENTHOL	OYSTER	SEA SALT
POPPYSEED	EUCALYPTUS	SCALLOP	GOJI
SAGE	PEACH		

## AKUSTO™ WALL C TEXONA

- 0.95 NRC ideal for open-plan offices, conference rooms, classrooms and libraries
- 106" x 24" rectangular panels available in 13 standard colors shown above

## STANDARD SHAPES

Rectangle



Circle

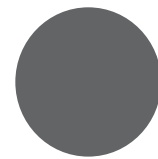

Square



## EASY INSTALLATION

- Lightweight panels have two mounting options:
  - Connect trim for larger panels
  - Connect hook for smaller panels
- 0.95 NRC for maximum sound absorption

## AKUSTO™ WALL C SUPER G™

- High impact and moisture resistant for gymnasiums, multi-purpose rooms and other active spaces
- 106" x 24" rectangular panels available in 3 standard colors — white, gray or blue

Discover what's possible with Clouds & Baffles.  
Visit [CertainTeed.com/architectural](http://CertainTeed.com/architectural) or call 800-233-8990.

**CertainTeed**  
SAINT-GOBAIN



**CertainTeed ARCHITECTURAL**

METAL • WOOD • FELT • FIBERGLASS & MINERAL FIBER • GYPSUM • SUSPENSION & INTEGRATED SYSTEMS  
20 Moores Road, Malvern, PA 19355 800-233-8990 [CertainTeed.com/Architectural](http://CertainTeed.com/Architectural)