

CertainTeed

# Gypsum Board Systems Manual

Fire Resistance and Sound Control Design Manual



Division 09

**CertainTeed**  
SAINT-GOBAIN

### Introduction

General	1
Fire Resistance	3
Sound Control	4
Sound Isolation Construction	5
Definitions	5
Testing Authorities	5
Estimates	6
Building Codes	6
Material and Application Standards	6
Assembly Codes	7

### Steel Stud Partitions - Non Load Bearing

Fire Resistance Rating - 3/4h	8
Fire Resistance Rating - 1h	8
Fire Resistance Rating - 2h	10
Fire Resistance Rating - 3h	12
Fire Resistance Rating - 4h	12

### Steel Stud Partitions - Interior - Load Bearing

Fire Resistance Rating - 1h	13
Fire Resistance Rating - 2h	13

### Steel Stud Partitions - Exterior - Non-Load Bearing

Fire Resistance Rating - 2h	13
-----------------------------	----

### Steel Stud Partitions - Exterior - Load Bearing

Fire Resistance Rating - 3/4h	14
Fire Resistance Rating - 1 1/2h	14

### Wood Stud Partitions - Interior - Load Bearing

Fire Resistance Rating - 3/4h	15
Fire Resistance Rating - 1h	15
Fire Resistance Rating - 1 1/2h	17
Fire Resistance Rating - 2h	17

### Wood Stud Partitions - Exterior - Load Bearing

Fire Resistance Rating - 1h	19
Fire Resistance Rating - 1 1/2h	19
Fire Resistance Rating - 2h	19

### Shaftwalls - Non-Load Bearing

Framing Details 1	20
Framing Details 2	21
Fire Resistance Rating - 1h	22
Fire Resistance Rating - 2h	22
Fire Resistance Rating - 3h	23

### Shaftwall Horizontal Systems - Non-Load Bearing

Fire Resistance Rating - 1h	24
Fire Resistance Rating - 2h	24

### Shaftwalls - Vertical Assembly Details

Details – Finished One Side	26
Details – Finished Both Sides	27
One Hour Details	32
Two Hour Details	33

<b>Area Separation Firewalls</b> .....	34
<b>Area Separation Firewalls - Non-Load Bearing</b>	
<i>Fire Resistance Rating - 2h</i> .....	36
<b>Steel Joist Floors &amp; Ceilings</b>	
<i>Fire Resistance Rating - 1h</i> .....	38
<i>Fire Resistance Rating - 1 1/2h</i> .....	38
<i>Fire Resistance Rating - 2h</i> .....	38
<i>Fire Resistance Rating - 3h</i> .....	39
<b>Wood Joist Floors &amp; Ceilings</b>	
<i>Fire Resistance Rating - 3/4h</i> .....	40
<i>Fire Resistance Rating - 1h</i> .....	40
<i>Fire Resistance Rating - 2h</i> .....	42
<b>Column &amp; Beam Protection</b>	
<i>Fire Resistance Rating - 1h</i> .....	43
<i>Fire Resistance Rating - 2h</i> .....	43
<i>Fire Resistance Rating - 3h</i> .....	43
<b>Concrete Block/Gypsum Board Walls</b>	
<i>Fire Resistance Rating - 2h</i> .....	44
<i>Fire Resistance Rating - 3h</i> .....	44
<b>Steel Stud PermaBase<sup>®</sup> Partitions</b>	
<i>Fire Resistance Rating - 1h</i> .....	45
<i>Fire Resistance Rating - 2h</i> .....	45
<b>Steel Stud PermaBase<sup>®</sup> Partitions - Chase Wall - Non-Load Bearing</b>	
<i>Fire Resistance Rating - 1h</i> .....	46
<i>Fire Resistance Rating - 2h</i> .....	47

### GENERAL

This manual is intended to provide architects, engineers and builders with reference data on Gypsum Board Systems incorporating CertainTeed Gypsum Canada gypsum board products. It contains sections on Partitions, Exterior Walls, Floors and Ceilings, Shaftwalls, Area Separation Firewalls, Cement Board and Column and Beam Protection. Each section lists the systems in ascending order of fire rating, and includes sound ratings and basic construction details.

The Gypsum Board Systems Manual is available on our web site at [www.certainteed.com](http://www.certainteed.com). Further assistance regarding the application of CertainTeed Gypsum Canada products in Gypsum Board Systems can be obtained by calling the CertainTeed Gypsum Canada office nearest you.

“Any product information, data or specifications contained in this Manual have been prepared with information available to CertainTeed Gypsum Canada at the time of printing and every effort has been made to ensure that all information, data and specifications are complete and accurate. Anyone making use of, or relying on, any information, data or specifications contained in this Manual, for any purpose whatsoever, expressly assumes any and all liability that may arise from such use or reliance. CertainTeed Gypsum Canada does not assume any responsibility for any errors or omissions that may be contained in this Manual. Any information, data or specifications contained in this Manual supercede any and all previous information, data or specifications prior to this manual and are subject to change without notice.”

### FIRE RESISTANCE

After two hour exposure to heat following CAN/ULC-S101 time-temperature curve:

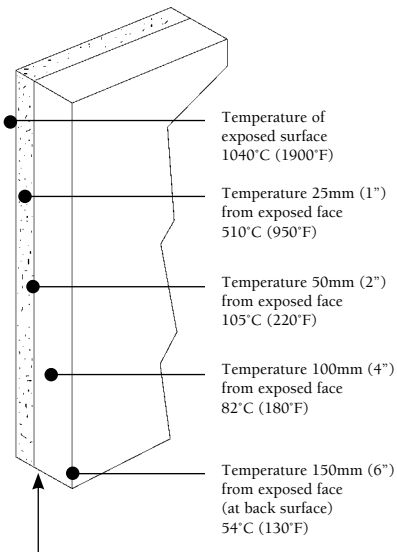

Vertical line represents plane of calcination. Temperature never greatly exceeds 100°C (212°F) behind plane of calcination.

#### How Gypsum Retards Heat Transmission

Gypsum board is the most commonly used fire resistive material and is equally well known as a reliable and economic surfacing material. When used in combination with other products, excellent fire resistive and sound control properties can be achieved.

Gypsum is a naturally occurring mineral mined or quarried in many locations throughout North America and in other parts of the world. When processed into gypsum board products the chemically combined water (about 21 percent by weight) contributes to its effectiveness as a fire barrier. When gypsum protected structural members are exposed to fire, the water is slowly released as steam, effectively retarding heat transmission and acting as a fire barrier until most of the chemically combined water is eliminated, a process known as calcination. The temperature directly behind the plane of calcination is only slightly higher than that of boiling water (100°C), and that is considerably below the temperature at which steel begins to lose its strength or lumber ignites. Once the gypsum is completely calcined, the residue acts as an insulating barrier to the flames.

DSG, or desulphogypsum, is high purity gypsum that is produced instead of mined. Traditionally, the gypsum raw material in the core of drywall has been mined from natural deposits. There are numerous underground and surface mines producing this gypsum for drywall manufacturing plants across North America. DSG is fundamentally the same raw material as mined gypsum, with a higher degree of purity. As a result, its properties are virtually the same as mined gypsum.

#### Type X Gypsum Board

There are two basic classifications of gypsum board core formulations giving different degrees of fire resistance. These are Standard and Type X gypsum board. Type X board by definition is a gypsum board that provides: a 60 minute fire endurance rating for a 15.9mm (5/8") thickness when applied in a single layer and properly fastened to each side of 92mm (3 5/8") steel framing members

or

a 2 hour fire resistant rating for a 12.7mm (1/2") thickness when applied in a double layer and properly fastened to each side of 64mm (2 1/2") steel framing members, when tested in accordance with CAN/ULC-S101.

Type X gypsum boards manufactured by CertainTeed Gypsum are described as either EGRG, GlasRoc®, Shaftliner, GlasRoc® Shaftliner, or Type X and these products are classified/listed by Underwriters Laboratories and Underwriters' Laboratories of Canada.

All CertainTeed Type X, CertainTeed Type C, CertainTeed Moisture Resistant Type X, CertainTeed Moisture Resistant Type C, CertainTeed Treated Core Sheathing Type X, CertainTeed Veneer Plaster Base Type X, CertainTeed Abuse, M2Tech® Type X, M2Tech® Shaftliner, GlasRoc® Sheathing Type X, GlasRoc® Shaftliner, Diamondback® Tile Backer Type X, AirRenew® M2Tech® Type X, AirRenew® Essential Type X, AirRenew® Extreme Abuse and AirRenew® Extreme Impact products meet both the CSA and ASTM definitions of Type X gypsum board.

CertainTeed Type C products and CertainTeed Moisture Resistant Type C products are proprietary products which meet the requirements of Type X and have further enhanced fire resistive properties. These products are often referred to as "Type C" gypsum board, although there is no industry definition for "Type C" gypsum board.

#### Fire Resistance Tests

There are a number of independent testing authorities capable of conducting fire tests to establish fire resistance classifications according to procedures outlined in:

CAN/ULC-S101 "Fire Endurance Tests of Building Construction and Materials."

ASTM E119 "Fire Tests of Building Construction and Materials."

The conditions for tests are thoroughly detailed and the time of failure is the time at which there is excessive heat transmission, passage of flame or structural failure. In addition, failure may result because of penetration by a pressurized hose stream required in the fire test procedure for walls.

Comprehensive research by fire protection agencies has determined the average combustible content to be expected for a given occupancy; also the time required for the contents to be consumed by fire and the resulting temperature. Thus, the average fire load may be predicted for a given occupancy, and fire resistance classifications are assigned accordingly in building codes and similar regulations.

In CAN/ULC Standard S101 fire tests, various wall, floor, roof, column and beam assemblies are exposed in a furnace which reaches the indicated average temperatures at the time stated in the standard time-temperature curve.

All of the walls and partitions tested and classified must be at least 9.3m<sup>2</sup> (100ft<sup>2</sup>) with no side dimension less than 2.75m (9 feet). Temperatures are measured at a minimum of nine points on the unexposed surface of the assembly. When testing load bearing walls and partitions the superimposed load applied shall simulate the working stress of the construction components.

The wall or partition must also stop flame or hot gasses capable of igniting cotton waste. The average temperature of the unexposed surface cannot increase more than 139°C (250°F) above ambient nor shall the temperature rise at any individual point exceed 181°C (325°F). It is also required that a duplicate of the assembly be fire tested for half the specified resistance period, after which it must withstand the impact, erosion and cooling effect of water under high pressure from a fire hose.

Floor and roof assemblies tested and classified have to be a minimum of 16.8m<sup>2</sup> (180ft<sup>2</sup>) with neither dimension less than 3.66m (12 feet). The assemblies must sustain the design load throughout the test and not allow either flame or hot gasses, capable of igniting cotton waste, to pass through. The unexposed surface temperature may not rise more than an average of 139°C (250°F) above the initial temperature nor shall the temperature rise at any individual point exceed 181°C (325°F).

### Surface Burning Characteristics

Flame spread ratings are intended as a guide in the selection and use of finishing materials and are obtained by measuring the extent and rapidity with which flames spread over their surfaces under test conditions.

Under certain circumstances some building codes may require the use of interior finish materials with a flame spread rating of not more than 25. The laboratory test generally used to establish a material's flame spread characteristic is referred to as the tunnel test:

CAN/ULC-S102 "Standard Method of Test for Surface Burning Characteristics of Building Materials and Assemblies."

This test measures relative flame spread, fuel contribution and the amount of smoke developed from the material being tested.

A method of numerical classification to permit comparison of a given material's flame spread performance with that of another has been established.

### Flame Spread Rating

---

Asbestos cement board 0 (control classification)

<b>Gypsum plaster</b>	<b>0</b>
<b>Gypsum lath</b>	<b>10</b>
<b>Gypsum board</b>	<b>10-15</b>
<b>Gypsum sheathing</b>	<b>15-20</b>
Red oak	100 (control classification)

---

The smoke developed by gypsum board is rated at 0.

### SOUND CONTROL

#### **Sound Transmission Class (STC)**

Drywall construction systems are tested to establish their sound insulation characteristics and airborne sound insulation is reported as the Sound Transmission Class (STC).

ASTM Standard E90 "Laboratory Measurement of Airborne Sound Transmission Loss of Building Partitions" outlines a procedure for measuring sound transmission loss which is the difference between the sound energy in a source room and a receiving room when the two rooms are separated by the assembly being tested. The sound transmission loss is measured at different test frequencies and this data is used to obtain a single number known as the STC rating calculated in accordance with ASTM E413.

#### **Sound Insulation**

STC values stated are based on laboratory tests. The actual STC ratings of assemblies as constructed may be significantly less due to deviations from the design or specified materials, flanking paths or poor workmanship. A first essential for airborne sound insulation using any assembly is to close off air leaks and flanking paths by which noise can go around the assembly. Hairline cracks or small holes will increase the sound transmission at the higher frequencies. This can have a detrimental effect on the overall acoustical performance and the STC particularly for higher rated assemblies.

Assemblies should be airtight. Recessed wall fixtures such as medicine cabinets, or electrical, telephone and television outlets, which perforate the gypsum board surface, should not be located back-to-back or in the same cavity. In addition, any opening for such fixtures and for piping outlets should be carefully cut to proper size and caulked. The entire perimeter of a sound insulating assembly must be made airtight to prevent sound flanking. An acoustical caulking compound or acoustical gasket should be used to seal between the assembly and all dissimilar surfaces. Taping gypsum board wall and wall-ceiling intersections provides an adequate air seal at these locations. Details of some typical problem areas and their recommended treatments are shown in the accompanying illustration.

### Sound Isolation Construction

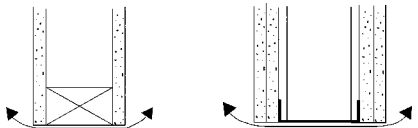
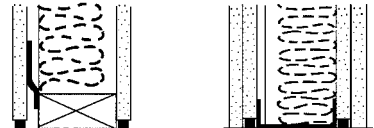
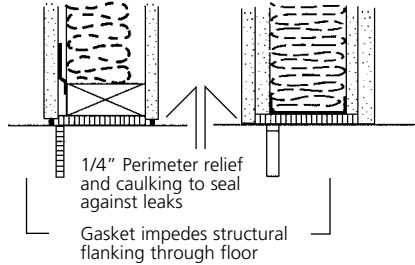
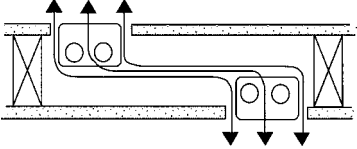
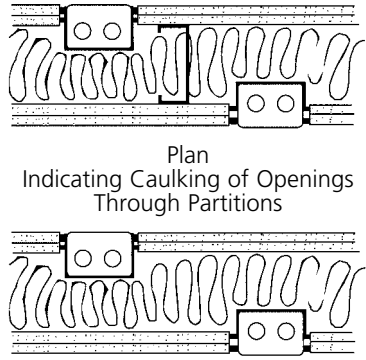
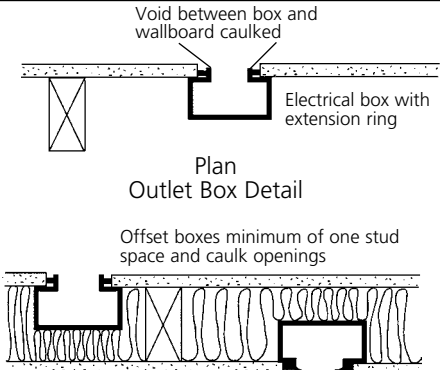
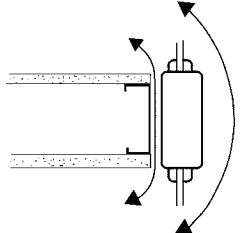
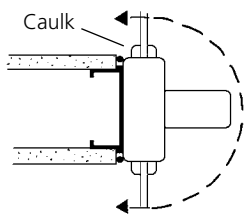
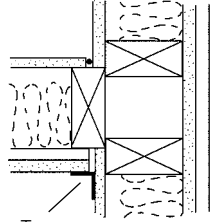
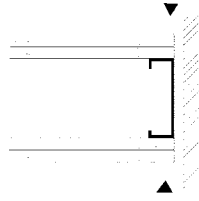
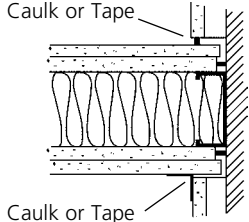
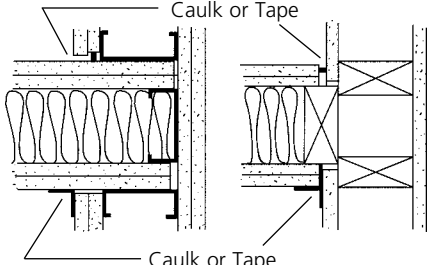
<p><b>“NORMAL CONSTRUCTION”</b> Not suitable for good sound control. Arrows show flanking paths</p>	<p><b>“SELECT CONSTRUCTION”</b> Caulking of relief detail at perimeter of partition to prevent sound leakage</p>	<p><b>“PRE-DESIGN” CONSTRUCTION</b> Simulating laboratory conditions</p>
 <p>Wood Stud System      Steel Stud System</p> <p>Elevation Under and Over Partitions</p>	 <p>Wood Stud      Metal Stud</p> <p>Elevation</p>	 <p>1/4" Perimeter relief and caulk to seal against leaks Gasket impedes structural flanking through floor</p> <p>Elevation Typical Floor-Ceiling or Roof Detail</p>
 <p>Plan Through Partitions, Openings, Outlet Boxes</p>	 <p>Plan Indicating Caulking of Openings Through Partitions</p>	 <p>Void between box and wallboard caulked Electrical box with extension ring</p> <p>Plan Outlet Box Detail</p> <p>Offset boxes minimum of one stud space and caulk openings</p>
<p>Window Mullion</p>  <p>Plan Around Flanking Partition Ends</p>	 <p>Caulk</p> <p>Plan Typical Partition Mullion Intersection</p>	 <p>Caulk or Tape</p> <p>Plan Intersection With Exterior Wall</p>
 <p>Plan Metal Stud Around Flanking Partition Ends</p>	 <p>Caulk or Tape</p> <p>Plan Intersection With Interior Wall</p>	 <p>Caulk or Tape</p> <p>Plan Typical Partition Intersections</p>



## DEFINITIONS

Definitions of “Fire Resistance Rating” and “STC” as used in this manual are as follows:

**Fire Resistance Rating:** The degree to which construction assemblies resist the passage of heat and flame is indicated by ratings determined by full scale fire resistance tests conducted in accordance with CAN/ULC-S101 or ASTM E119.

**STC:** Sound Transmission Class, a single number which represents the overall performance of an assembly at all sound frequencies. As per ASTM E90 and E413, the higher the STC, the more efficient the system for reducing sound transmission.

## TESTING AUTHORITIES

Abbreviations for the testing authorities cited in this manual are as follows:

### Fire Resistance Ratings

NBCC	National Building Code of Canada
ULC	Underwriters' Laboratories of Canada
ITS	Intertek Testing Services (Formerly Warnock Hersey International)
UL	Underwriters Laboratories
cUL	Underwriters Laboratories
NRC	National Research Council, Canada

### Sound Ratings

NBCC	National Building Code of Canada
NRC	National Research Council, Canada
WHI	Warnock Hersey International (now Intertek)
RAL	Riverbank Acoustical Laboratories
OL	Orfield Laboratories, Inc.
NGC	NGC Testing Services

## ESTIMATES

Not all of the assemblies in this catalogue have been individually tested. Where no specific test data is available, an estimated rating is provided for guidance only. CertainTeed Gypsum Canada makes no claim that these estimates comply with, or are acceptable under, any building code.

These estimates are based on a judgement of how the particular assembly might react, when compared with similar ones which have been tested in accordance with recognized standards.

If specific compliance is required, tests should be conducted.

### BUILDING CODES

Within Canada, Building Codes govern among other items, the type, use and application of construction materials. It is therefore important that the user, when determining the suitability of products and assemblies outlined in this manual, ensure that the requirements of the applicable Building Code(s) have been met.

### MATERIAL AND APPLICATION STANDARDS

Gypsum board products and many of the accessories that are utilized in the construction and/or finishing of gypsum board are covered by standards. These standards set forth minimum requirements for their physical and/or performance characteristics, limits of use and methods of application.

The following major Standards Writing Authorities are cited in this manual.

ASTM	American Society for Testing and Materials
CSA	Canadian Standards Association
GA	Gypsum Association

#### CertainTeed Gypsum Canada Materials

CertainTeed Gypsum Canada gypsum board products are manufactured to meet or exceed the following standards.

#### CertainTeed Gypsum Canada Gypsum Board Product

Gypsum Board Product	Standard(s)
CertainTeed Regular + 54"	CAN/CSA-A82.27, ASTM C1396
CertainTeed Type X + Type C	CAN/CSA-A82.27, ASTM C1396
CertainTeed Treated Core Sheathing + Type X	CAN/CSA-A82.27, ASTM C1396
CertainTeed Moisture Resistant + Type X	CAN/CSA-A82.27, ASTM C1396
CertainTeed Veneer Plaster Base + Type X + Type C	CAN/CSA-A82.27, ASTM C1396
CertainTeed Interior Ceiling	CAN/CSA-A82.27, ASTM C1396
Easi-Lite™	CAN/CSA-A82.27, ASTM C1396
Easi-Lite™ Interior Ceiling	CAN/CSA-A82.27, ASTM C1396
Easi-Lite™ Veneer Plaster Base	CAN/CSA-A82.27, ASTM C1396
M2Tech® Regular, Type X, Type C, Shaftliner	CAN/CSA-A82.27, ASTM C1396
GlasRoc® Shaftliner	ASTM C1658
GlasRoc® Sheathing + Type X	ASTM C1177
CertainTeed Exterior Soffit + Type X + Type C	CAN/CSA-A82.27, ASTM C1396
Diamondback® Tile Backer + Type X	ASTM C1178
AirRenew® M2Tech® + Type X	CAN/CSA-A82.27, ASTM C1396
AirRenew® Essential + Type X	CAN/CSA-A82.27, ASTM C1396
AirRenew® Extreme Abuse	CAN/CSA-A82.27, ASTM C1396
AirRenew® Extreme Impact	CAN/CSA-A82.27, ASTM C1396

#### Accessory Materials

The materials used in conjunction with CertainTeed Gypsum Canada gypsum board products should be manufactured to meet or exceed the following standards.

Material	Standard(s)
Steel Stud	ASTM C645, ASTM C955
Steel Track	ASTM C645, ASTM C955
Steel Furring Channel	ASTM C645
Wood Framing Members	CAN/CSA O141
Drywall Screws	ASTM C1002, ASTM C954
Drywall Nails	CSA B111, ASTM C514
Adhesives	ASTM C577
Joint Compounds	ASTM C475
Joint Tape	ASTM C475
Gypsum Plaster	ASTM C28
Accessories	ASTM C1047

#### Application Standards

NBCC National Building Code of Canada  
 CAN/CSA-A82.31 Gypsum Board Application  
 ASTM C840 Application and Finishing of Gypsum Board  
 ASTM C844 Application of Gypsum Base to Receive Gypsum Veneer Plaster  
 ASTM C1280 Application of Exterior Gypsum Panel Products for Use as Sheathing  
 Gypsum Association, GA-216, GA-253, and GA-214

## ASSEMBLY CODES

### Walls

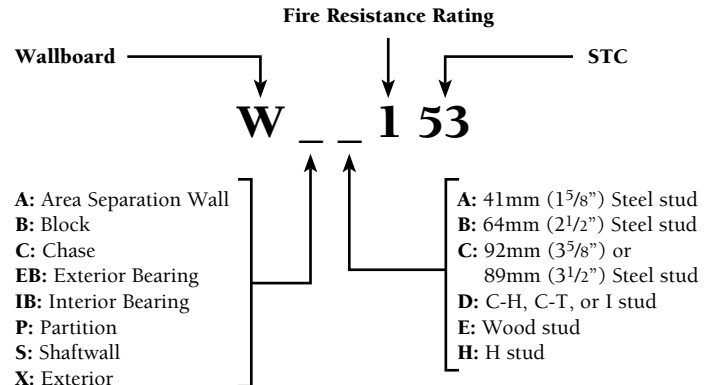

### Floor-Ceilings

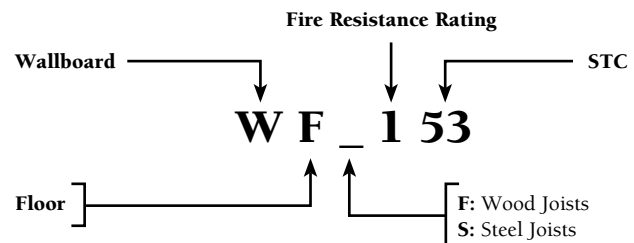

### Columns and Beams

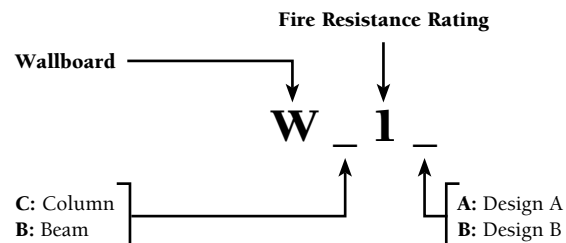

### PermaBase

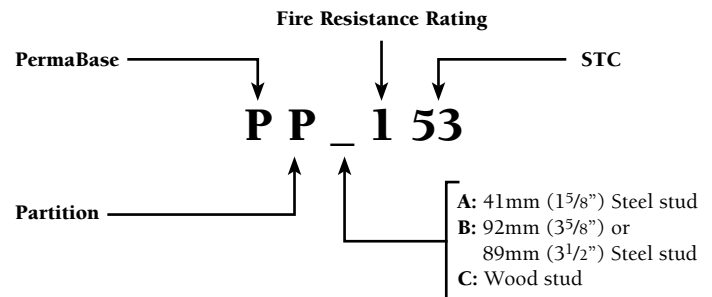

# STEEL STUD PARTITIONS

## Non-Load Bearing

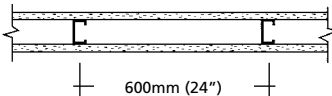
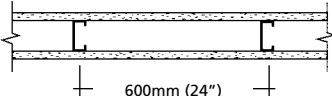
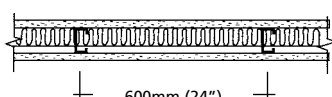
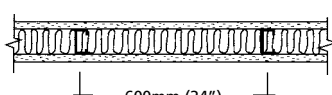
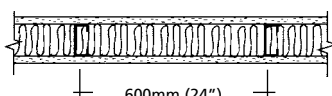
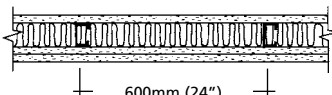
SOUND TRANSMISSION CLASS (STC)	CONSTRUCTION	DESCRIPTION	DESIGN NUMBER/TEST REPORTS
<b>FIRE RESISTANCE RATING: 3/4h</b>			
35	 <p>Thickness: 95mm (3 3/4") Weight: 25 kg/m<sup>2</sup> (5.0 lb/ft<sup>2</sup>)</p>	<p><b>System WPB035</b> 15.9mm (5/8") CertainTeed Type X products, 1 layer, each side of 64mm (2 1/2") steel studs. Fasten boards vertically using 32mm (1 1/4") screws spaced 200mm (8") o.c. along floor and ceiling tracks, and 300mm (12") o.c. along edge joints and in the field. Joints must be offset. Tape and finish joints with CertainTeed products.</p>	<p>FIRE: ULC W409 SOUND: NBCC (2010) Table A-9.10.3.1.A Wall S1c</p>
<b>FIRE RESISTANCE RATING: 1h</b>			
38	 <p>Thickness: 124mm (4 7/8") Weight: 25 kg/m<sup>2</sup> (5.1 lb/ft<sup>2</sup>)</p>	<p><b>System WPC138</b> 15.9mm (5/8") CertainTeed Type X products, 1 layer, each side of 92mm (3 5/8") steel studs. Fasten boards vertically or horizontally using 25mm (1") screws spaced 200mm (8") o.c. along edge joints, floor and ceiling tracks, and 300mm (12") o.c. in the field. Joints must be offset. If boards are applied horizontally, horizontal edge joints and horizontal butt joints need not be staggered or backed by steel framing. Fasten boards horizontally using 25mm (1") screws spaced 200mm (8") o.c. Tape and finish joints with CertainTeed products.</p>	<p>FIRE: ULC W415 / cUL U465, UL U465 SOUND: NBCC (2010) Table A-9.10.3.1.A Wall S4c</p>
43	 <p>Thickness: 89mm (3 1/2") Weight: 25 kg/m<sup>2</sup> (5.1 lb/ft<sup>2</sup>)</p>	<p><b>System WPB143</b> 12.7mm (1/2") CertainTeed Type C products, 1 layer, each side of 64mm (2 1/2") steel studs. Mineral wool insulation 38mm (1 1/2") within cavity. Fasten boards vertically using 25mm (1") screws spaced 200mm (8") o.c. along edge joints, floor and ceiling tracks, and 300mm (12") o.c. in the field. Joints must be offset. Tape and finish joints with CertainTeed products.</p>	<p>FIRE: ULC W412 SOUND: NRC 795</p>
46	 <p>Thickness: 95mm (3 3/4") Weight: 26 kg/m<sup>2</sup> (5.4 lb/ft<sup>2</sup>)</p>	<p><b>System WPB146</b> 15.9mm (5/8") CertainTeed Type X products, 1 layer, each side of 64mm (2 1/2") steel studs. CertainTeed's Sustainable Insulation™ 65mm (2 1/2") within cavity. Fasten boards vertically using 32mm (1 1/4") screws spaced 200mm (8") o.c. along floor and ceiling tracks, and 300mm (12") o.c. along edge joints and in the field. Joints must be offset. Tape and finish joints with CertainTeed products.</p>	<p>FIRE: ULC W409 SOUND: NRC 804</p>
50	 <p>Thickness: 124mm (4 7/8") Weight: 27 kg/m<sup>2</sup> (5.5 lb/ft<sup>2</sup>)</p>	<p><b>System WPC150</b> 15.9mm (5/8") CertainTeed Type X products, 1 layer, each side of 92mm (3 5/8") steel studs. CertainTeed's Sustainable Insulation™ 89mm (3 1/2") within cavity. Fasten boards vertically using 25mm (1") screws spaced 200mm (8") o.c. along edge joints, floor and ceiling tracks, and 300mm (12") o.c. in the field. Joints must be offset. Tape and finish joints with CertainTeed products.</p>	<p>FIRE: Based on WPC 138 (ULC W415, cUL U465, UL U465) SOUND: NRC TL-93-324</p>
50	 <p>Thickness: 102mm (4") Weight: 31 kg/m<sup>2</sup> (6.3 lb/ft<sup>2</sup>)</p>	<p><b>System WPB150</b> 12.7mm (1/2") CertainTeed Type C products, 1 layer on one side, 2 layers other side of 64mm (2 1/2") steel studs. CertainTeed's Sustainable Insulation™ 65mm (2 1/2") within cavity. Fasten one side vertically using 25mm (1") screws spaced 200mm (8") o.c. at the perimeter and 300mm (12") in the field. Opposite side applied vertically. Base layer installed with 25mm (1") screws spaced 400mm (16") and face layer installed with 41mm (1 5/8") screws spaced 400mm (16") o.c. offset 200mm (8") from base layer screws. Joints staggered.</p>	<p>FIRE: ULC W498 SOUND: NBCC (2010) Table A-9.10.3.1.A Wall S2c</p>

# STEEL STUD PARTITIONS

## Non-Load Bearing

SOUND TRANSMISSION CLASS (STC)	CONSTRUCTION	DESCRIPTION	DESIGN NUMBER/ TEST REPORTS
<b>FIRE RESISTANCE RATING: 1h (continued)</b>			
51	<p>Thickness: 111mm (4 3/8") Weight: 38 kg/m<sup>2</sup> (7.8 lb/ft<sup>2</sup>)</p>	<p><b>System WPB151</b> 15.9mm (5/8") CertainTeed Type X products, 1 layer on one side, 2 layers other side of 64mm (2 1/2") steel studs. CertainTeed's Sustainable Insulation™ 64mm (2 1/2") within cavity.</p> <p>Fasten base layers vertically using 32mm (1 1/4") screws spaced 200mm (8") o.c. along floor and ceiling tracks, and 300mm (12") o.c. along edge joints and in the field. Fasten second layer vertically on one side using 41mm (1 5/8") screws spaced 300mm (12") o.c. Joints must be offset. Tape and finish outer layer joints with CertainTeed products.</p>	<p>FIRE: Based on WPB 146 (ULC W409)</p> <p>SOUND: NRC 805</p>
52	<p>Thickness: 130 mm (5 1/8") Weight: 38 kg/m<sup>2</sup> (7.8 lb/ft<sup>2</sup>)</p>	<p><b>System WPC152</b> 12.7mm (1/2") CertainTeed Type C products, 2 layers one side, 1 layer other side of 92mm (3 5/8") steel studs. CertainTeed's Sustainable Insulation™ 89mm (3 5/8") within cavity.</p> <p>Fasten one side vertically using 25mm (1") screws spaced 200mm (8") o.c. at the perimeter and 300mm (12") in the field. Opposite side applied vertically. Base layer installed with 25mm (1") screws spaced 400mm (16") and face layer installed with 41mm (1 5/8") screws spaced 400mm (16") o.c. offset 200mm (8") from base layer screws. Joints staggered. Tape and finish outer layer joints with CertainTeed products.</p>	<p>FIRE: ULC W498</p> <p>SOUND: NRC TL-92-411</p>
53	<p>Thickness: 108mm (4 1/4") Weight: 33 kg/m<sup>2</sup> (6.8 lb/ft<sup>2</sup>)</p>	<p><b>System WPB153</b> 12.7mm (1/2") CertainTeed Type C products, 1 layer, and 9.5mm (3/8") CertainTeed or M2Tech® Regular, 1 layer, each side of 64mm (2 1/2") steel studs. CertainTeed's Sustainable Insulation™ 64mm (2 1/2") within cavity.</p> <p>Fasten 9.5mm (3/8") base layers vertically using 25mm (1") screws spaced 300mm (12") o.c. Laminate 12.7mm (1/2") face layers vertically using joint compound and 32mm (1 1/4") screws spaced 200mm (8") o.c. along floor and ceiling track. Joints must be offset. Optional taping and finishing of outer layer joints with CertainTeed products.</p>	<p>FIRE: ULC W402</p> <p>SOUND: BGL 691</p>
53	<p>Thickness: 140mm (5 1/2") Weight: 38 kg/m<sup>2</sup> (7.8 lb/ft<sup>2</sup>)</p>	<p><b>System WPC153</b> 15.9mm (5/8") CertainTeed Type X products, 1 layer on one side, 2 layers other side of 92mm (3 5/8") steel studs. CertainTeed's Sustainable Insulation™ 89mm (3 1/2") within cavity.</p> <p>Fasten base layers vertically using 25mm (1") screws spaced 200mm (8") o.c. along edge joints, and 300mm (12") o.c. in the field. Fasten second layer vertically or horizontally on one side using 41mm (1 5/8") screws spaced 300mm (12") o.c. Joints must be offset. Tape and finish outer layer joints with CertainTeed products.</p>	<p>FIRE: Based on WPC138 (ULC W415, cUL U465, UL U465)</p> <p>SOUND: NRC 811</p>
54	<p>Thickness: 185mm (7 1/3") Weight: 28 kg/m<sup>2</sup> (5.7 lb/ft<sup>2</sup>)</p>	<p><b>System WCB154</b> 15.9mm (5/8") CertainTeed Type X products or Diamondback® Tile Backer Type X, 1 layer either sides of double row 64mm (2 1/2") wide 20 gauge steel studs separated by 25mm (1") air space. 22mm x 22mm (7/8" x 7/8") 20 gauge channels as horizontal bracing a minimum of every 1500mm (60"). CertainTeed's Sustainable Insulation™ 89mm (3 1/2") within one or both cavities. Insulation optional for fire rating.</p> <p>Vertical application: Boards installed with 25mm (1") Type S-12 screws 200mm (8") o.c. on each side of the assembly. Joints staggered.</p> <p>Horizontal application: Boards installed with 25mm (1") Type S-12 screws 200mm (8") o.c. on each side of the assembly. Joints need not be staggered.</p>	<p>FIRE: cUL V469, UL V469</p> <p>SOUND: RAL-TL06-299</p>

**NOTE:** For other high STC assemblies see 2 hour fire ratings

# STEEL STUD PARTITIONS

## Non-Load Bearing

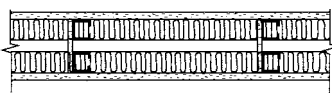
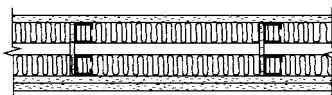
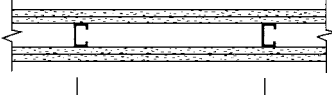
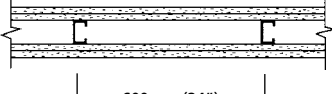
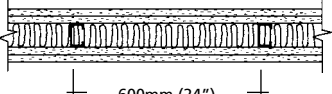
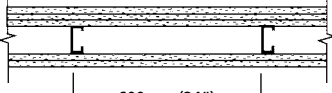
SOUND TRANSMISSION CLASS (STC)	CONSTRUCTION	DESCRIPTION	DESIGN NUMBER/TEST REPORTS
<b>FIRE RESISTANCE RATING: 1h (continued)</b>			
55	 <p data-bbox="239 514 479 567">Thickness: 127mm (5") Weight: 29 kg/m<sup>2</sup> (6.0 lb/ft<sup>2</sup>)</p>	<p data-bbox="612 380 806 409"><b>System WCA155</b></p> <p data-bbox="612 409 1305 462">15.9mm (5/8") CertainTeed Type X products, 1 layer, each side of paired 41mm (1 1/8") steel studs. CertainTeed's Sustainable Insulation™ 64mm (2 1/2") each side within cavity.</p> <p data-bbox="612 472 1305 598">Attach 15.9mm x 300mm (5/8" x 12") CertainTeed Type X products bridging 1200mm (48") o.c. to steel studs using screws (3 per stud). Fasten boards vertically using 25mm (1") screws spaced 200mm (8") o.c. along edge joints, floor and ceiling tracks, and 300mm (12") o.c. in the field. Joints must be offset. Tape and finish joints with CertainTeed products.</p>	<p data-bbox="1334 380 1462 430">FIRE: cUL U420, UL U420</p> <p data-bbox="1334 451 1503 483">SOUND: NRC-93-300</p>
61	 <p data-bbox="239 793 479 840">Thickness: 143mm (5 5/8") Weight: 41 kg/m<sup>2</sup> (8.4 lb/ft<sup>2</sup>)</p>	<p data-bbox="612 646 806 676"><b>System WCA161</b></p> <p data-bbox="612 676 1305 751">15.9mm (5/8") CertainTeed Type X products, 1 layer on one side, 2 layers other side of paired 41mm (1 5/8") steel studs. CertainTeed's Sustainable Insulation™ 64mm (2 1/2") each side within cavity.</p> <p data-bbox="612 762 1305 924">Attach 240mm x 300mm (9 1/2" x 12") CertainTeed Type X products bridging 1200mm (48") o.c. to steel studs using screws (3 per stud). Fasten base layers vertically using 25mm (1") screws spaced 200mm (8") o.c. along edge joints, and 300mm (12") o.c. in the field. Fasten second layer vertically or horizontally on one side using 41mm (1 5/8") screws spaced 300mm (12") o.c. Joints must be offset. Tape and finish outer layer joints with CertainTeed products.</p>	<p data-bbox="1334 646 1503 720">FIRE: Based on WCA155 (cUL U420, UL U420)</p> <p data-bbox="1334 741 1503 772">SOUND: NRC-93-301</p>
<b>FIRE RESISTANCE RATING: 2h</b>			
44	 <p data-bbox="239 1144 479 1197">Thickness: 114mm (4 1/2") Weight: 39 kg/m<sup>2</sup> (8.1 lb/ft<sup>2</sup>)</p>	<p data-bbox="612 1024 806 1054"><b>System WPB244</b></p> <p data-bbox="612 1054 1305 1106">12.7mm (1/2") CertainTeed Type C products, 2 layers, each side of 64mm (2 1/2") steel studs.</p> <p data-bbox="612 1117 1305 1197">Fasten base layers vertically using 25mm (1") screws spaced 300mm (12") o.c. Fasten face layers vertically using 41mm (1 5/8") screws spaced 300mm (12") o.c. Joints must be offset. Tape and finish outer layer joints with CertainTeed products.</p>	<p data-bbox="1334 1024 1462 1054">FIRE: ULC W414</p> <p data-bbox="1334 1075 1503 1155">SOUND: NBCC (2010) Table A-9.10.3.1.A Wall S3i</p>
45	 <p data-bbox="239 1360 479 1413">Thickness: 127mm (5") Weight: 48 kg/m<sup>2</sup> (9.8 lb/ft<sup>2</sup>)</p>	<p data-bbox="612 1245 806 1274"><b>System WPB245</b></p> <p data-bbox="612 1274 1305 1327">15.9mm (5/8") CertainTeed Type X products, 2 layers, each side of 64mm (2 1/2") steel studs.</p> <p data-bbox="612 1337 1305 1417">Fasten base layers vertically using 25mm (1") screws spaced 300mm (12") o.c. Fasten face layers vertically using 41mm (1 5/8") screws spaced 300mm (12") o.c. Joints must be offset. Tape and finish outer layer joints with CertainTeed products.</p>	<p data-bbox="1334 1245 1503 1297">FIRE: ULC W414/ cUL U411, UL U411</p> <p data-bbox="1334 1318 1503 1396">SOUND: NBCC (2010) Table A-9.10.3.1.A Wall S3g</p>
53	 <p data-bbox="239 1570 479 1623">Thickness: 114mm (4 1/2") Weight: 41 kg/m<sup>2</sup> (8.4 lb/ft<sup>2</sup>)</p>	<p data-bbox="612 1455 806 1484"><b>System WPB253</b></p> <p data-bbox="612 1484 1305 1537">12.7mm (1/2") CertainTeed Type C products, 2 layers, each side of 64mm (2 1/2") steel studs. CertainTeed's Sustainable Insulation™ 64mm (2 1/2") within cavity.</p> <p data-bbox="612 1547 1305 1627">Fasten base layers vertically using 25mm (1") screws spaced 300mm (12") o.c. Fasten face layers vertically using 41mm (1 5/8") screws spaced 300mm (12") o.c. Joints must be offset. Tape and finish outer layer joints with CertainTeed products.</p>	<p data-bbox="1334 1455 1462 1528">FIRE: Based on WPB244 (ULC W414)</p> <p data-bbox="1334 1549 1503 1581">SOUND: NRC 798</p>
54	 <p data-bbox="239 1780 479 1833">Thickness: 171mm (6 3/4") Weight: 59 kg/m<sup>2</sup> (12 lb/ft<sup>2</sup>)</p>	<p data-bbox="612 1665 806 1694"><b>System WPC254</b></p> <p data-bbox="612 1694 1305 1747">15.9mm (5/8") CertainTeed Type X products, 3 layers on one side, 2 layers other side of 92mm (3 5/8") steel studs. No insulation.</p> <p data-bbox="612 1757 1305 1885">Fasten base layers vertically using 25mm (1") screws spaced 300mm (12") o.c. Fasten second layers vertically using 41mm (1 5/8") screws spaced 300mm (12") o.c. Fasten third layer vertically or horizontally on one side with 57mm (2 1/4") screws spaced 300mm (12") o.c. Joints must be offset. Tape and finish outer layer joints with CertainTeed products.</p>	<p data-bbox="1334 1665 1503 1759">FIRE: Based on WPB245 (ULC W414, cUL U411, UL U411)</p> <p data-bbox="1334 1780 1503 1837">SOUND: NRC TL-92-371</p>

# STEEL STUD PARTITIONS

## Non-Load Bearing

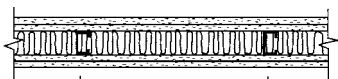
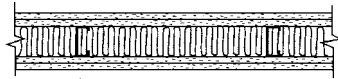
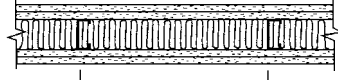
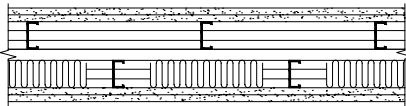
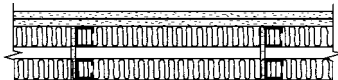
SOUND TRANSMISSION CLASS (STC)	CONSTRUCTION	DESCRIPTION	DESIGN NUMBER/TEST REPORTS
<b>FIRE RESISTANCE RATING: 2h (continued)</b>			
54	 <p data-bbox="232 472 469 504">600mm (24")</p> <p data-bbox="232 514 469 562">Thickness: 127mm (5") Weight: 49 kg/m<sup>2</sup> (10 lb/ft<sup>2</sup>)</p>	<p data-bbox="612 388 801 415"><b>System WPB254</b></p> <p data-bbox="612 415 1280 472">15.9mm (5/8") CertainTeed Type X products, 2 layers, each side of 64mm (2 1/2") steel studs. CertainTeed's Sustainable Insulation™ 64mm (2 1/2") within cavity.</p> <p data-bbox="612 478 1280 562">Fasten base layers vertically using 25mm (1") screws spaced 300mm (12") o.c. Fasten face layers vertically using 41mm (1 3/8") screws spaced 300mm (12") o.c. Joints must be offset. Tape and finish outer layer joints with CertainTeed products.</p>	<p data-bbox="1339 388 1503 493">FIRE: Based on WPB245 (ULC W414, cUL U411, UL U411)</p> <p data-bbox="1339 514 1478 541">SOUND: NRC 806</p>
56	 <p data-bbox="232 688 469 720">600mm (24")</p> <p data-bbox="232 730 469 779">Thickness: 156mm (6 1/8") Weight: 50 kg/m<sup>2</sup> (10 lb/ft<sup>2</sup>)</p>	<p data-bbox="612 604 801 632"><b>System WPC256</b></p> <p data-bbox="612 632 1280 688">15.9mm (5/8") CertainTeed Type X products, 2 layers, each side of 92mm (3 5/8") steel studs. CertainTeed's Sustainable Insulation™ 89mm (3 1/2") within cavity.</p> <p data-bbox="612 695 1280 779">Fasten base layers vertically using 25mm (1") screws spaced 300mm (12") o.c. Fasten face layers vertically using 41mm (1 3/8") screws spaced 300mm (12") o.c. Joints must be offset. Tape and finish outer layer joints with CertainTeed products.</p>	<p data-bbox="1339 604 1503 709">FIRE: Based on WPB245 (ULC W414, cUL U411, UL U411)</p> <p data-bbox="1339 730 1478 758">SOUND: NRC 812</p>
57	 <p data-bbox="232 905 469 936">600mm (24")</p> <p data-bbox="232 947 469 995">Thickness: 143mm (5 5/8") Weight: 41 kg/m<sup>2</sup> (8.5 lb/ft<sup>2</sup>)</p>	<p data-bbox="612 821 801 848"><b>System WPC257</b></p> <p data-bbox="612 848 1280 905">12.7mm (1/2") CertainTeed Type C products, 2 layers, each side of 92mm (3 5/8") steel studs. CertainTeed's Sustainable Insulation™ 89mm (3 1/2") within cavity.</p> <p data-bbox="612 911 1280 995">Fasten base layers vertically using 25mm (1") screws spaced 300mm (12") o.c. Fasten face layers vertically using 41mm (1 3/8") screws spaced 300mm (12") o.c. Joints must be offset. Tape and finish outer layer joints with CertainTeed products.</p>	<p data-bbox="1339 821 1503 905">FIRE: Based on WPB244 (ULC W414)</p> <p data-bbox="1339 926 1503 953">SOUND: NGC 2006049</p>
63	 <p data-bbox="232 1157 469 1188">600mm (24")</p> <p data-bbox="232 1220 469 1276">Thickness: 217mm (8 1/2") Weight: 50kg/m<sup>2</sup> (10.2lb/ft<sup>2</sup>)</p>	<p data-bbox="612 1045 801 1073"><b>System WCB263</b></p> <p data-bbox="612 1073 1280 1213">15.9mm (5/8") CertainTeed Type X products or Diamondback® Tile Backer Type X, 2 layers both sides of double row 64mm (2 1/2") wide 20 gauge steel studs separated by 25mm (1") air space. 22mm x 22mm (7/8" x 7/8") 20 gauge channels as horizontal bracing a minimum of every 1500mm (60"). CertainTeed's Sustainable Insulation™ 89mm (3 1/2") within one or both cavities. Insulation optional for fire rating.</p> <p data-bbox="612 1220 1280 1297">Vertical application: Base layer installed with 25mm (1") Type S-12 screws 400mm (16") o.c. and face layer installed with 41mm (1 3/8") Type S-12 screws 200mm (8") o.c. on each side of the assembly. Joints staggered.</p> <p data-bbox="612 1304 1280 1409">Horizontal application: Base layer installed with 25mm (1") Type S-12 screws 400mm (16") o.c. and face layer installed with 41mm (1 3/8") Type S-12 screws 400mm (16") o.c. on each side of the assembly. Face and base layer joints to be staggered a minimum of 300mm (12").</p>	<p data-bbox="1339 1045 1503 1102">FIRE: cUL V469, UL V469</p> <p data-bbox="1339 1115 1503 1171">SOUND: RAL-TL06-300</p>
65	 <p data-bbox="232 1556 469 1587">600mm (24")</p> <p data-bbox="232 1598 469 1675">Thickness: 172mm (6 3/4") Weight: 49 kg/m<sup>2</sup> (10 lb/ft<sup>2</sup>)</p>	<p data-bbox="612 1472 801 1499"><b>System WCA265</b></p> <p data-bbox="612 1499 1280 1577">15.9mm (5/8") CertainTeed, M2Tech® or Diamondback® Tile Backer Type X, 2 layers, each side of paired 41mm (1 3/8") steel studs. CertainTeed's Sustainable Insulation™ 64mm (2 1/2") each side within cavity.</p> <p data-bbox="612 1583 1280 1774">Attach 240mm x 300mm (9 1/2" x 12") CertainTeed or M2Tech® Type X bridging 1200mm (48") o.c. to steel studs using screws (3 per stud). Fasten base layers vertically using 25mm (1") screws spaced 200mm (8") o.c. along edge joints, floor and ceiling tracks, and 300mm (12") o.c. in the field. Fasten face layers vertically using 41mm (1 3/8") screws spaced 200mm (8") o.c. along edge joints, floor and ceiling tracks, and 300mm (12") o.c. in the field. Joints must be offset. Tape and finish outer layer joints with CertainTeed products.</p>	<p data-bbox="1339 1472 1503 1528">FIRE: cUL U420, UL U420</p> <p data-bbox="1339 1541 1503 1577">SOUND: NRC-93-321</p>

# STEEL STUD PARTITIONS

## Non-Load Bearing

SOUND TRANSMISSION CLASS (STC)	CONSTRUCTION	DESCRIPTION	DESIGN NUMBER/TEST REPORTS
--------------------------------	--------------	-------------	----------------------------

### FIRE RESISTANCE RATING: **3h**

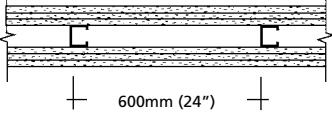
44	 <p>Thickness: 118mm (4 5/8") Weight: 58 kg/m<sup>2</sup> (12 lb/ft<sup>2</sup>)</p>	<p><b>System WPA344</b> 12.7mm (1/2") CertainTeed Type C products, 3 layers, each side of 41mm (1 5/8") steel studs.</p> <p>Fasten base layers vertically using 25mm (1") screws spaced 300mm (12") o.c. Fasten second layers vertically using 41mm (1 5/8") screws spaced 300mm (12") o.c. Fasten third layers vertically or horizontally with 57mm (2 1/4") screws spaced 300mm (12") o.c. Note, for horizontal applications use 38mm (1 1/2") Type G screws along the horizontal edge and in the field between studs. Joints must be offset. Tape and finish outer layer joints with CertainTeed products.</p>	<p>FIRE: ULC W418 SOUND: NRC 1072</p>
----	---	---	---

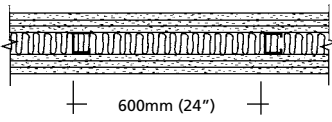
52	 <p>Thickness: 118mm (4 5/8") Weight: 60 kg/m<sup>2</sup> (12 lb/ft<sup>2</sup>)</p>	<p><b>System WPA352</b> 12.7mm (1/2") CertainTeed Type C products, 3 layers, each side of 41mm (1 5/8") steel studs. Mineral wool insulation 38mm (1 1/2") within cavity.</p> <p>Fasten base layers vertically using 25mm (1") screws spaced 300mm (12") o.c. Fasten second layers vertically using 41mm (1 5/8") screws spaced 300mm (12") o.c. Fasten third layers vertically or horizontally with 57mm (2 1/4") screws spaced 300mm (12") o.c. Note, for horizontal applications use 38mm (1 1/2") Type G screws along the horizontal edge and in the field between studs. Joints must be offset. Tape and finish outer layer joints with CertainTeed products.</p>	<p>FIRE: Based on WPA344 (cUL U463, UL U463) SOUND: NRC 1073</p>
----	---	--	--

### FIRE RESISTANCE RATING: **4h**

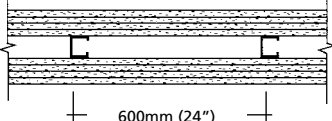
49	 <p>Thickness: 143mm (5 5/8") Weight: 77 kg/m<sup>2</sup> (16 lb/ft<sup>2</sup>)</p>	<p><b>System WPA449</b> 12.7mm (1/2") CertainTeed Type C products, 4 layers, each side of 41mm (1 5/8") steel studs.</p> <p>Fasten base layers vertically using 25mm (1") screws spaced 300mm (12") o.c. Fasten second layers vertically using 41mm (1 5/8") screws spaced 300mm (12") o.c. Fasten third layers vertically with 57mm (2 1/4") screws spaced 300mm (12") o.c. Fasten fourth layers vertically or horizontally with 67mm (2 3/8") screws spaced 300mm (12") o.c. Note, for horizontal applications use 38mm (1 1/2") Type G screws along the horizontal edge and in the field between studs. Joints must be offset. Tape and finish outer layer joints with CertainTeed products.</p>	<p>FIRE: ULC W418 SOUND: NRC 1075</p>
----	---	---	---

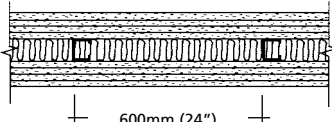
56	 <p>Thickness: 143mm (5 5/8") Weight: 79 kg/m<sup>2</sup> (16 lb/ft<sup>2</sup>)</p>	<p><b>System WPA456</b> 12.7mm (1/2") CertainTeed Type C products, 4 layers, each side of 41mm (1 5/8") steel studs. CertainTeed's Sustainable Insulation™ 38mm (1 1/2") within cavity.</p> <p>Fasten base layers vertically using 25mm (1") screws spaced 300mm (12") o.c. Fasten second layers vertically using 41mm (1 5/8") screws spaced 300mm (12") o.c. Fasten third layers vertically with 57mm (2 1/4") screws spaced 300mm (12") o.c. Fasten fourth layers vertically or horizontally with 67mm (2 3/8") screws spaced 300mm (12") o.c. Note, for horizontal applications use 38mm (1 1/2") Type G screws along the horizontal edge and in the field between studs. Joints must be offset. Tape and finish outer layer joints with CertainTeed products.</p>	<p>FIRE: Based on WPA449 (cUL U463, UL U463) SOUND: NRC 1074</p>
----	---	--	--



# STEEL STUD PARTITIONS

## Interior – Load Bearing

SOUND TRANSMISSION CLASS (STC)	CONSTRUCTION	DESCRIPTION	DESIGN NUMBER/TEST REPORTS
--------------------------------	--------------	-------------	----------------------------

### FIRE RESISTANCE RATING: **1h**

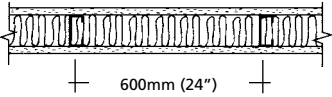
48	 <p>Thickness: 121mm (4 3/4") Weight: 27 kg/m<sup>2</sup> (5.6 lb/ft<sup>2</sup>)</p>	<p><b>System WIBC148</b> 15.9mm (5/8") CertainTeed Type X products, 1 layer, each side of 89mm (3 1/2") 20 ga. load bearing steel studs. CertainTeed's Sustainable Insulation™ 89mm (3 1/2") within cavity.</p> <p>Fasten boards vertically using 25mm (1") screws spaced 300mm (12") o.c. Joints must be offset. Tape and finish joints with CertainTeed products.</p>	<p>FIRE: cUL U425, UL U425</p> <p>SOUND: OL12-0922</p>
----	--	---	--

### FIRE RESISTANCE RATING: **2h**

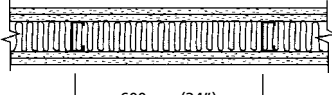
54	 <p>Thickness: 153mm (6") Weight: 50 kg/m<sup>2</sup> (10 lb/ft<sup>2</sup>)</p>	<p><b>System WIBC254</b> 15.9mm (5/8") CertainTeed Type X products, 2 layers, each side 89mm (3 1/2") 20 ga. load bearing steel studs. CertainTeed's Sustainable Insulation™ 89mm (3 1/2") within cavity.</p> <p>Fasten base layers vertically using 25mm (1") screws spaced 300mm (12") o.c. Fasten face layers vertically using 41mm (1 1/8") screws spaced 300mm (12") o.c. Joints must be offset. Tape and finish outer layer joints with CertainTeed products.</p>	<p>FIRE: cUL U425, UL U425</p> <p>SOUND: OL12-0924</p>
----	---	---	--

# STEEL STUD PARTITIONS

## Exterior – Non-Load Bearing

### FIRE RESISTANCE RATING: **2h**

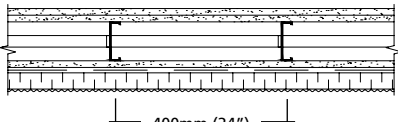
 <p>Thickness: 296mm (11 5/8")</p>	<p><b>System WPC2XX</b> Assembly rated for fire exposure from interior side only. 15.9mm (5/8") CertainTeed Type X products, 2 layers on interior side of 92mm (3 5/8") wide steel studs with steel channel bracing inserted through the stud cutouts at 1220mm (48") o.c. and attached to studs with clip angles and screws. 15.9mm (5/8") GlasRoc® Sheathing Type X, 1 layer on exterior side of steel studs. Exterior finished with expanded polystyrene insulation and Durabond Products Ltd's EIFS system. Interior finished with CertainTeed products.</p> <p>Interior side: Fasten base layer vertically using 32mm (1 1/4") screws 150mm (6") o.c. on the perimeter and 200mm (8") o.c. in the field. Fasten face layer vertically using 41mm (1 1/8") screws 150mm (6") o.c. on the perimeter and 200mm (8") o.c. in the field. Joints must be offset 600mm (24").</p> <p>Exterior side: Fasten sheathing using 41mm (1 1/8") screws 200mm (8") o.c. on the perimeter and 300mm (12") o.c. in the field. Joints between sheathing to be covered with 120mm (5") fiberglass seam tape and with a proprietary Durabond Products Ltd's EIFS system.</p>	<p>FIRE: ULC W456</p>
---	---	-----------------------

# STEEL STUD PARTITIONS

## Exterior – Load Bearing

SOUND TRANSMISSION CLASS (STC)	CONSTRUCTION	DESCRIPTION	DESIGN NUMBER/TEST REPORTS
--------------------------------	--------------	-------------	----------------------------

### FIRE RESISTANCE RATING: **3/4h**

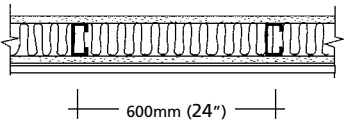

49	 <p data-bbox="236 531 518 625">Thickness: 118mm (4 5/8") plus exterior finish Weight: 25 kg/m<sup>2</sup> (5.1 lb/ft<sup>2</sup>) plus exterior finish</p>	<p data-bbox="609 394 822 415"><b>System WEBC049</b></p> <p data-bbox="609 417 1268 520">15.9mm (5/8") CertainTeed Type X products, 1 layer, interior side, 12.7mm (1/2") CertainTeed Treated Core Sheathing or GlasRoc® Sheathing, 1 layer, exterior side of 89mm (3 1/2") 20 ga. load bearing steel studs. CertainTeed's Sustainable Insulation™, exterior finish.</p> <p data-bbox="609 531 1268 667">Fasten CertainTeed Treated Core Sheathing or GlasRoc® Sheathing vertically to the exterior side using 25mm (1") screws spaced 300mm (12") o.c. Fasten CertainTeed Type X products vertically to the interior side using 25mm (1") screws spaced 300mm (12") o.c. Joints must be offset. Tape and finish interior joints with CertainTeed products.</p>	<p data-bbox="1339 394 1466 436">FIRE: cUL U425, UL U425</p> <p data-bbox="1339 464 1514 489">SOUND: OL12-0926</p>
----	--	---	--

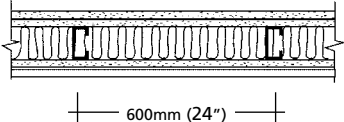
### FIRE RESISTANCE RATING: **1-1/2h**

53	 <p data-bbox="236 909 502 1003">Thickness: 134mm (5 1/4") plus exterior finish Weight: 36 kg/m<sup>2</sup> (7.4 lb/ft<sup>2</sup>) plus exterior finish</p>	<p data-bbox="609 772 822 793"><b>System WEBC153</b></p> <p data-bbox="609 795 1268 898">15.9mm (5/8") CertainTeed Type X products, 2 layers, interior side, 12.7mm (1/2") CertainTeed Treated Core Sheathing or GlasRoc® Sheathing, 1 layer, exterior side of 89mm (3 1/2") 20 ga. load bearing steel studs. CertainTeed's Sustainable Insulation™, exterior finish.</p> <p data-bbox="609 909 1268 1050">Fasten CertainTeed Treated Core Sheathing or GlasRoc® Sheathing vertically to the exterior side using 25mm (1") screws spaced 300mm (12") o.c. Fasten base layer vertically to the interior side using 25mm (1") screws spaced 300mm (12") o.c. Fasten face layer vertically to the using 41mm (1 5/8") screws spaced 300mm (12") o.c. Joints must be offset. Tape and finish interior joints with CertainTeed products.</p>	<p data-bbox="1339 772 1466 814">FIRE: cUL U425, UL U425</p> <p data-bbox="1339 842 1514 867">SOUND: OL12-0925</p>
----	---	---	--

# WOOD STUD PARTITIONS

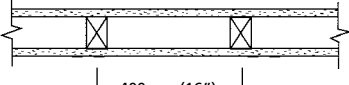
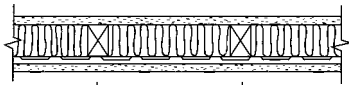
## Interior – Load Bearing

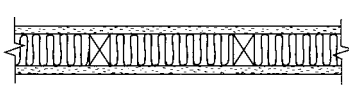
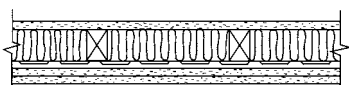
SOUND TRANSMISSION CLASS (STC)	CONSTRUCTION	DESCRIPTION	DESIGN NUMBER/TEST REPORTS
<b>FIRE RESISTANCE RATING: 3/4h</b>			
<b>32</b> (with insulation STC 34)	 <p data-bbox="239 504 470 556">Thickness: 114mm (4 1/2") Weight: 27 kg/m<sup>2</sup> (5.4 lb/ft<sup>2</sup>)</p>	<p data-bbox="612 388 801 415"><b>System WPE032</b></p> <p data-bbox="612 415 1247 472">12.7mm (1/2") CertainTeed Type C products, 1 layer, each side of 38mm x 89mm (2 x 4) wood studs.</p> <p data-bbox="612 478 1247 556">Fasten boards vertically using 44mm (1 3/4") nails spaced 175mm (7") o.c. Joints must be offset. Tape and finish joints with CertainTeed products. Widths other than 1200mm (48") must be installed horizontally.</p>	<p data-bbox="1339 388 1470 409">FIRE: ULC W302</p> <p data-bbox="1339 436 1504 514">SOUND: NBCC (2010) Table A-9.10.3.1.A - Wall W1e &amp; W1b</p>
<b>45</b>	 <p data-bbox="239 724 470 777">Thickness: 133mm (5 1/4") Weight: 33 kg/m<sup>2</sup> (6.8 lb/ft<sup>2</sup>)</p>	<p data-bbox="612 588 801 615"><b>System WPE045</b></p> <p data-bbox="612 615 1272 693">15.9mm (5/8") CertainTeed Type X products, 1 layer on 38mm x 89mm (2 x 4) wood studs, one side on resilient channels. CertainTeed's Sustainable Insulation™ 89mm (3 1/2") within cavity.</p> <p data-bbox="612 699 1272 913">Fasten board vertically or horizontally to one side with 41mm (1 5/8") screws spaced 300mm (12") o.c. Attach resilient channels with tabs downwards, horizontally at 400mm (16") or 600mm (24") o.c. to studs on opposite side with 32mm (1 1/4") screws. Upper channel 150mm (6") from top, lower channel 400mm (16") up from bottom and at the bottom of the partition, install an inverted channel. Fasten board vertically or horizontally to the resilient channels with 25mm (1") screws spaced 300mm (12") o.c. Joints must be offset. Tape and finish joints with CertainTeed products.</p>	<p data-bbox="1339 588 1504 682">FIRE: NBCC (2010) Table A-9.10.3.1.A Wall W3a (cUL U305, UL U305)</p> <p data-bbox="1339 709 1504 787">SOUND: NBCC (2010) Table A-9.10.3.1.A Wall W3a</p>
<b>FIRE RESISTANCE RATING: 1h</b>			
<b>32</b>	 <p data-bbox="239 1155 470 1207">Thickness: 121mm (4 3/4") Weight: 31 kg/m<sup>2</sup> (6.3 lb/ft<sup>2</sup>)</p>	<p data-bbox="612 1029 801 1056"><b>System WPE132</b></p> <p data-bbox="612 1056 1247 1113">15.9mm (5/8") CertainTeed Type X products, 1 layer, each side of 38mm x 89mm (2 x 4) wood studs.</p> <p data-bbox="612 1119 1247 1176">Fasten boards vertically using 51mm (2") nails spaced 175mm (7") o.c. Joints must be offset. Tape and finish joints with CertainTeed products.</p>	<p data-bbox="1339 1029 1504 1081">FIRE: ULC W 301, cUL U305, UL U305</p> <p data-bbox="1339 1108 1504 1186">SOUND: NBCC (2010) Table A-9.10.3.1.A Wall W1d</p>
<b>34</b>	 <p data-bbox="239 1375 470 1428">Thickness: 114mm (4 1/2") Weight: 30 kg/m<sup>2</sup> (6.2 lb/ft<sup>2</sup>)</p>	<p data-bbox="612 1239 801 1266"><b>System WPE134</b></p> <p data-bbox="612 1266 1255 1323">12.7mm (1/2") CertainTeed Type C products, 1 layer, each side of 38mm x 89mm (2 x 4) wood studs. Mineral wool insulation 89mm (3 1/2") within cavity.</p> <p data-bbox="612 1329 1255 1407">Fasten boards vertically using 32mm (1 1/4") screws spaced 300mm (12") o.c.; or 32mm (1 1/4") nails spaced 200mm (8") o.c. Joints must be offset. Tape and finish joints with CertainTeed products.</p>	<p data-bbox="1339 1239 1504 1312">FIRE: NBCC (2010) Table A-9.10.3.1.A Wall W1b</p> <p data-bbox="1339 1339 1504 1417">SOUND: NBCC (2010) Table A-9.10.3.1.A Wall W1b</p>
<b>51</b>	 <p data-bbox="239 1596 470 1648">Thickness: 149mm (5 7/8") Weight: 44 kg/m<sup>2</sup> (9.1 lb/ft<sup>2</sup>)</p>	<p data-bbox="612 1449 801 1476"><b>System WPE151</b></p> <p data-bbox="612 1476 1280 1564">15.9mm (5/8") CertainTeed Type X products, 1 layer, 1 side of 38mm x 89mm (2 x 4) wood studs. Other side, 2 layers on resilient channels. CertainTeed's Sustainable Insulation™ 89mm (3 1/2") within cavity.</p> <p data-bbox="612 1570 1280 1810">Fasten board vertically or horizontally to one side with 41mm (1 5/8") screws spaced 300mm (12") o.c. Attach resilient channels with tabs downwards, horizontally at 400mm (16") or 600mm (24") o.c. to studs on opposite side with 32mm (1 1/4") screws. Upper channel 150mm (6") from top, lower channel 400mm (16") up from bottom and at the bottom of the partition, install an inverted channel. Fasten base layer vertically to the resilient channels with 25mm (1") screws spaced 300mm (12") o.c. Fasten face layer vertically or horizontally with 41mm (1 5/8") screws spaced 300mm (12") o.c. Joints must be offset. Tape and finish outer layer joints with CertainTeed products.</p>	<p data-bbox="1339 1449 1504 1554">FIRE: NBCC (2010) Table A-9.10.3.1.A Wall W4a (cUL U305, UL U305)</p> <p data-bbox="1339 1581 1504 1659">SOUND: NBCC (2010) Table A-9.10.3.1.A Wall W4a</p>

# WOOD STUD PARTITIONS

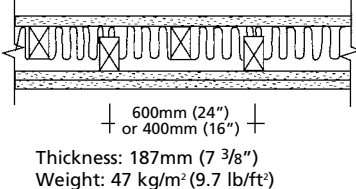
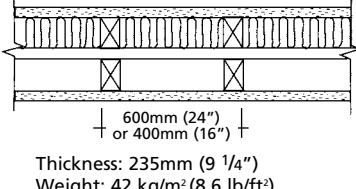
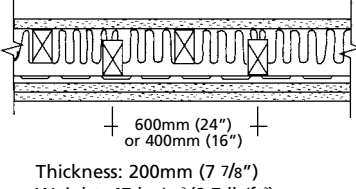
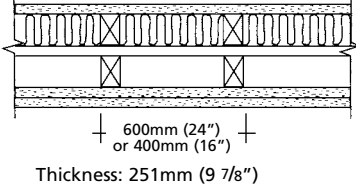
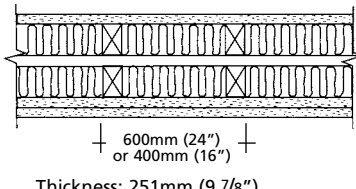

## Interior – Load Bearing

SOUND TRANSMISSION CLASS (STC)	CONSTRUCTION	DESCRIPTION	DESIGN NUMBER/TEST REPORTS
<b>FIRE RESISTANCE RATING: 1h (continued)</b>			
<b>52</b>	 <p>600mm (24") or 400mm (16")</p> <p>Thickness: 187mm (7 3/8") Weight: 47 kg/m<sup>2</sup> (9.7 lb/ft<sup>2</sup>)</p>	<p><b>System WPE152</b> 15.9mm (5/8") CertainTeed Type X products, 1 layer, 1 side of staggered 38mm x 89mm (2 x 4) wood studs. Other side, 2 layers. CertainTeed's Sustainable Insulation™ 89mm (3 1/2") within cavity.</p> <p>Fasten base layers vertically or horizontally using 41mm (1 1/8") screws spaced 300mm (12") o.c.; or 38mm (1 1/2") nails spaced 200mm (8") o.c. Fasten face layer to one side vertically or horizontally using 51mm (2") screws spaced 300mm (12") o.c.; or 51mm (2") nails spaced 200mm (8") o.c. Joints must be offset. Tape and finish outer layer joints with CertainTeed products.</p>	<p>FIRE: NBCC (2010) Table A-9.10.3.1.A Wall W8a</p> <p>SOUND: NBCC (2010) Table A-9.10.3.1.A Wall W8a</p>
<b>54</b>	 <p>600mm (24") or 400mm (16")</p> <p>Thickness: 235mm (9 1/4") Weight: 42 kg/m<sup>2</sup> (8.6 lb/ft<sup>2</sup>)</p>	<p><b>System WPE154</b> 15.9mm (5/8") CertainTeed Type X products, 1 layer, each side of double row of 38mm x 89mm (2 x 4) wood studs. CertainTeed's Sustainable Insulation™ 89mm (3 1/2") within cavity, 1 side.</p> <p>Set plates 25mm (1") apart. Fasten boards vertically or horizontally using 41mm (1 1/8") screws spaced 300mm (12") o.c.; or 38mm (1 1/2") nails spaced 200mm (8") o.c. Joints must be offset. Tape and finish joints with CertainTeed products.</p>	<p>FIRE: NBCC (2010) Table A-9.10.3.1.A Wall W13c</p> <p>SOUND: NBCC (2010) Table A-9.10.3.1.A Wall W13c</p>
<b>56</b>	 <p>600mm (24") or 400mm (16")</p> <p>Thickness: 200mm (7 7/8") Weight: 47 kg/m<sup>2</sup> (9.7 lb/ft<sup>2</sup>)</p>	<p><b>System WPE156</b> 15.9mm (5/8") CertainTeed Type X products, 1 layer, 1 side of staggered 38mm x 89mm (2 x 4) wood studs on common 38mm x 140mm (2" x 6") plate. Other side, 2 layers on resilient channels. CertainTeed's Sustainable Insulation™ 89mm (3 1/2") within cavity.</p> <p>Fasten board vertically or horizontally to one side with 41mm (1 1/8") screws spaced 300mm (12") o.c. Attach resilient channels with tabs downwards, horizontally at 400mm (16") or 600mm (24") o.c. to studs on opposite side with 32mm (1 1/4") screws. Upper channel 150mm (6") from top, lower channel 400mm (16") up from bottom and at the bottom of the partition, install an inverted channel. Fasten base layer vertically to the resilient channels with 25mm (1") screws spaced 300mm (12") o.c. Fasten face layer vertically or horizontally with 41mm (1 1/8") screws spaced 300mm (12") o.c. Joints must be offset. Tape and finish outer layer joints with CertainTeed products.</p>	<p>FIRE: NBCC (2010) Table A-9.10.3.1.A Wall W11a</p> <p>SOUND: NBCC (2010) Table A-9.10.3.1.A Wall W11a</p>
<b>57</b>	 <p>600mm (24") or 400mm (16")</p> <p>Thickness: 251mm (9 7/8") Weight: 53 kg/m<sup>2</sup> (10.9 lb/ft<sup>2</sup>)</p>	<p><b>System WPE157</b> 15.9mm (5/8") CertainTeed Type X products, 1 layer, 1 side of double row of 38mm x 89mm (2 x 4) wood studs. Other side, 2 layers. CertainTeed's Sustainable Insulation™ 89mm (3 1/2") within cavity, 1 side.</p> <p>Set plates 25mm (1") apart. Fasten base layers vertically or horizontally using 41mm (1 1/8") screws spaced 300mm (12") o.c.; or 38mm (1 1/2") nails spaced 200mm (8") o.c. Fasten face layer to one side vertically or horizontally using 51mm (2") screws spaced 300mm (12") o.c.; or 51mm (2") nails spaced 200mm (8") o.c. Joints must be offset. Tape and finish outer layer joints with CertainTeed products.</p>	<p>FIRE: NBCC (2010) Table A-9.10.3.1.A Wall W14c</p> <p>SOUND: NBCC (2010) Table A-9.10.3.1.A Wall W14c</p>
<b>61</b>	 <p>600mm (24") or 400mm (16")</p> <p>Thickness: 251mm (9 7/8") Weight: 56 kg/m<sup>2</sup> (11.4 lb/ft<sup>2</sup>)</p>	<p><b>System WPE161</b> 15.9mm (5/8") CertainTeed Type X products, 1 layer, 1 side of double row 38mm x 89mm (2 x 4) wood studs. Other side, 2 layers. CertainTeed's Sustainable Insulation™ 89mm (3 1/2") within cavity, both sides.</p> <p>Set plates 25mm (1") apart. Fasten base layers vertically or horizontally using 41mm (1 1/8") screws spaced 300mm (12") o.c.; or 38mm (1 1/2") nails spaced 200mm (8") o.c. Fasten face layer to one side vertically or horizontally using 51mm (2") screws spaced 300mm (12") o.c.; or 51mm (2") nails spaced 200mm (8") o.c. Joints must be offset. Tape and finish outer layer joints with CertainTeed products.</p>	<p>FIRE: NBCC (2010) Table A-9.10.3.1.A Wall W14a</p> <p>SOUND: NBCC (2010) Table A-9.10.3.1.A Wall W14a</p>

\* Note: For other high STC assemblies see 1 1/2 and 2 hour fire ratings.

# WOOD STUD PARTITIONS

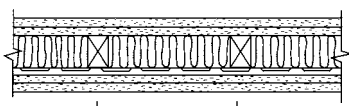
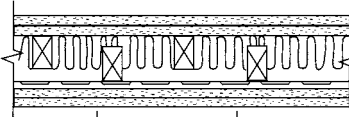
## Interior – Load Bearing

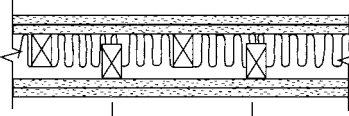
SOUND TRANSMISSION CLASS (STC)	CONSTRUCTION	DESCRIPTION	DESIGN NUMBER/TEST REPORTS
<b>FIRE RESISTANCE RATING: 1-1/2h</b>			
<b>58</b>	 <p data-bbox="231 504 487 598">           Thickness: 165mm (6 1/2")            Weight: 56 kg/m<sup>2</sup> (11.5 lb/ft<sup>2</sup>)         </p>	<p data-bbox="602 388 801 420"><b>System WPE158</b></p> <p data-bbox="602 420 1321 493">15.9mm (5/8") CertainTeed Type X products, 2 layers, 1 side 38mm x 89mm (2 x 4) wood studs. Other side, 2 layers on resilient channels. CertainTeed's Sustainable Insulation™ 89mm (3 1/2") within cavity.</p> <p data-bbox="602 504 1321 745">Fasten base layer vertically or horizontally to one side with 41mm (1 5/8") screws spaced 300mm (12") o.c. Fasten face layer vertically or horizontally with 51mm (2") screws spaced 300mm (12") o.c. Attach resilient channels with tabs down, horizontally at 600mm (24") o.c. to studs on opposite side with 32mm (1 1/4") screws. Upper channel 150mm (6") from top, lower channel 600mm (24") up from bottom and at the bottom of the partition, install an inverted channel. Fasten base layer vertically to the resilient channels with 25mm (1") screws spaced 300mm (12") o.c. Fasten face layer vertically or horizontally with 41mm (1 5/8") screws spaced 300mm (12") o.c. Joints must be offset. Tape and finish outer layer joints with CertainTeed products.</p>	<p data-bbox="1338 388 1511 462">FIRE: NBCC (2010) Table A-9.10.3.1.A Wall W6b</p> <p data-bbox="1338 493 1511 567">SOUND: NBCC (2010) Table A-9.10.3.1.A Wall W6b</p>
<b>62</b>	 <p data-bbox="231 924 487 1018">           Thickness: 216mm (8 1/2")            Weight: 59 kg/m<sup>2</sup> (12 lb/ft<sup>2</sup>)         </p>	<p data-bbox="602 808 801 840"><b>System WPE162</b></p> <p data-bbox="602 840 1321 913">15.9mm (5/8") CertainTeed Type X products, 2 layers, 1 side of staggered 38mm x 89mm (2 x 4) wood studs. Other side, 2 layers on resilient channels. CertainTeed's Sustainable Insulation™ 89mm (3 1/2") within cavity.</p> <p data-bbox="602 924 1321 1186">Fasten base layer vertically or horizontally to one side with 41mm (1 5/8") screws spaced 300mm (12") o.c. Fasten face layer vertically or horizontally with 51mm (2") screws spaced 300mm (12") o.c. Attach resilient channels with tabs down, horizontally at 400mm (16") o.c. or 600mm (24") o.c. to studs on opposite side with 32mm (1 1/4") screws. Upper channel 150mm (6") from top, lower channel 400mm (16") up from bottom and at the bottom of the partition, install an inverted channel. Fasten base layer vertically to the resilient channels with 25mm (1") screws spaced 300mm (12") o.c. Fasten face layer vertically or horizontally with 41mm (1 5/8") screws spaced 300mm (12") o.c. Joints must be offset. Tape and finish outer layer joints with CertainTeed products.</p>	<p data-bbox="1338 808 1511 882">FIRE: NBCC (2010) Table A-9.10.3.1.A Wall W10a</p> <p data-bbox="1338 913 1511 987">SOUND: NBCC (2010) Table A-9.10.3.1.A Wall W10a</p>
<b>FIRE RESISTANCE RATING: 2h</b>			
<b>36</b> (with insulation STC 38)	 <p data-bbox="231 1396 487 1480">           Thickness: 152mm (6")            Weight: 54 kg/m<sup>2</sup> (11 lb/ft<sup>2</sup>)         </p>	<p data-bbox="602 1291 801 1323"><b>System WPE236</b></p> <p data-bbox="602 1323 1321 1375">15.9mm (5/8") CertainTeed Type X products, 2 layers, each side of 38mm x 89mm (2 x 4) wood studs.</p> <p data-bbox="602 1386 1321 1491">Fasten base layers vertically or horizontally using 48mm (1 7/8") nails spaced 150mm (6") o.c. Fasten face layers vertically or horizontally using 60mm (2 3/8") nails spaced 200mm (8") o.c. Joints must be offset. Tape and finish outer layer joints with CertainTeed products.</p>	<p data-bbox="1338 1291 1511 1344">FIRE: cUL U301, UL U301</p> <p data-bbox="1338 1375 1511 1449">SOUND: NBCC (2010) Table A-9.10.3.1.A Wall W2d, W2a</p>
<b>56</b>	 <p data-bbox="231 1669 487 1732">           Thickness: 203mm (8")            Weight: 59 kg/m<sup>2</sup> (12 lb/ft<sup>2</sup>)         </p>	<p data-bbox="602 1554 801 1585"><b>System WPE256</b></p> <p data-bbox="602 1585 1321 1638">15.9mm (5/8") CertainTeed Type X products, 2 layers, each side of staggered 38mm x 89mm (2 x 4) wood studs. CertainTeed's Sustainable Insulation™ 89mm (3 1/2") within cavity.</p> <p data-bbox="602 1648 1321 1753">Fasten base layers vertically or horizontally using 48mm (1 7/8") nails spaced 150mm (6") o.c. Fasten face layers vertically or horizontally using 60mm (2 3/8") nails spaced 200mm (8") o.c. Joints must be offset. Tape and finish outer layer joints with CertainTeed products.</p>	<p data-bbox="1338 1554 1511 1606">FIRE: Based on WPE236 (cUL U301, UL U301)</p> <p data-bbox="1338 1627 1511 1701">SOUND: NBCC (2010) Table A-9.10.3.1.A Wall W9a</p>

# WOOD STUD PARTITIONS

## Interior – Load Bearing

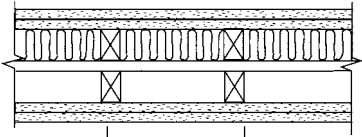
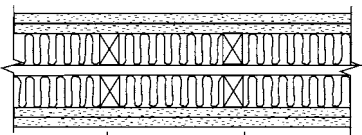
SOUND TRANSMISSION CLASS (STC)	CONSTRUCTION	DESCRIPTION	DESIGN NUMBER/TEST REPORTS
<b>FIRE RESISTANCE RATING: 2h (continued)</b>			
<b>62</b>	 <p style="text-align: center;">400mm (16")</p> <p style="text-align: center;">Thickness: 267mm (10 1/2") Weight: 65 kg/m<sup>2</sup> (13.2 lb/ft<sup>2</sup>)</p>	<p><b>System WPE262</b> 15.9mm (5/8") CertainTeed Type X products, 2 layers, each side of double row of 38mm x 89mm (2 x 4) wood studs. CertainTeed's Sustainable Insulation™ 89mm (3 1/2") within cavity, 1 side.</p> <p>Set plates 25mm (1") apart. Fasten base layers vertically or horizontally using 48mm (1 7/8") nails spaced 150mm (6") o.c. Fasten face layers vertically or horizontally using 60mm (2 3/8") nails spaced 200mm (8") o.c. Joints must be offset. Tape and finish outer layer joints with CertainTeed products.</p>	<p>FIRE: Based on WPE236 (cUL U301, UL U301)</p> <p>SOUND: NBCC (2010) Table A-9.10.3.1.A Wall W15d</p>
<b>66</b>	 <p style="text-align: center;">400mm (16")</p> <p style="text-align: center;">Thickness: 267mm (10 1/2") Weight: 67 kg/m<sup>2</sup> (13.7 lb/ft<sup>2</sup>)</p>	<p><b>System WPE266</b> 15.9mm (5/8") CertainTeed Type X products, 2 layers, each side of double row of 38mm x 89mm (2 x 4) wood studs. CertainTeed's Sustainable Insulation™ 89mm (3 1/2") within cavity, both sides.</p> <p>Set plates 25mm (1") apart. Fasten base layers vertically or horizontally using 48mm (1 7/8") nails spaced 150mm (6") o.c. Fasten face layers vertically or horizontally using 60mm (2 3/8") nails spaced 200mm (8") o.c. Joints must be offset. Tape and finish outer layer joints with CertainTeed products.</p>	<p>FIRE: Based on WPE236 (cUL U301, UL U301)</p> <p>SOUND: NBCC (2010) Table A-9.10.3.1.A Wall W15a</p>

# WOOD STUD PARTITIONS

## Exterior - Load Bearing

SOUND TRANSMISSION CLASS (STC)

CONSTRUCTION

DESCRIPTION

DESIGN NUMBER/TEST REPORTS

### FIRE RESISTANCE RATING: 1h

36

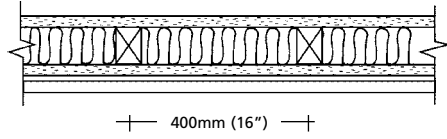

Thickness: 121mm (4 3/4") (plus cladding)  
Weight: 31 kg/m<sup>2</sup> (6.3 lb/ft<sup>2</sup>) (plus cladding)

#### System WXE136

Fasten 1 layer of 15.9mm (5/8") CertainTeed Type X products vertically to interior side of 38mm x 89mm (2 x 4) wood studs. Fasten 1 layer of 15.9mm (5/8") CertainTeed Treated Core Sheathing Type X or GlasRoc® Sheathing Type X vertically to exterior side. CertainTeed's Sustainable Insulation™ 89mm (3 1/2") within cavity. 51mm (2") nails spaced 175mm (7") o.c. Joints must be offset. Tape and finish interior joints with CertainTeed products. Exterior cladding system applied.

FIRE: ULC W301

SOUND: NBCC (2010)  
Table A-9.10.3.1.A  
Wall W1a

37

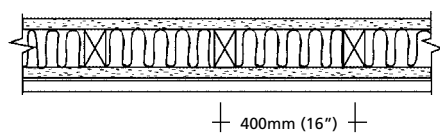

Thickness: 117mm (4 5/8") (plus cladding)  
Weight: 33 kg/m<sup>2</sup> (6.7 lb/ft<sup>2</sup>) (plus cladding)

#### System WXE137

Fasten 1 layer of 15.9mm (5/8") CertainTeed Type X products vertically or horizontally to interior side of 38mm x 89mm (2 x 4) wood studs with 38mm (1 1/2") drywall nails spaced 200mm (8") o.c. or 41mm (1 5/8") screws spaced 300mm (12") o.c. Fasten 1 layer of 12.7mm (1/2") CertainTeed Treated Core Sheathing or GlasRoc® Sheathing horizontally to exterior side with 44mm (1 3/4") roofing nails spaced 150mm (6") o.c. Mineral wool insulation 89mm (3 1/2") within cavity. Joints must be offset. Tape and finish interior joints with CertainTeed products. Exterior cladding system applied.

FIRE: NBCC (2010)  
Table A-9.10.3.1.A  
Wall EW1a

SOUND: Estimated

### FIRE RESISTANCE RATING: 1 1/2h

38

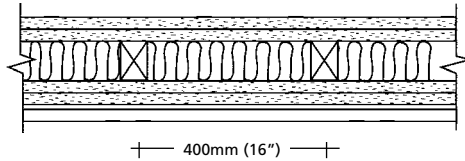

Thickness: 152mm (6") (plus cladding)  
Weight: 54 kg/m<sup>2</sup> (11 lb/ft<sup>2</sup>) (plus cladding)

#### System WXE238

Fasten base layer of 15.9mm (5/8") CertainTeed Type X products vertically or horizontally to interior side of 38mm x 89mm (2 x 4) wood studs with 48mm (1 7/8") nails spaced 150mm (6") o.c. Fasten face layer of 15.9mm (5/8") CertainTeed or M2Tech® Type X vertically or horizontally with 60mm (2 3/8") nails spaced 200mm (8") o.c. Fasten base layer of 15.9mm (5/8") CertainTeed Treated Core Sheathing Type X or GlasRoc® Sheathing Type X vertically or horizontally to exterior side 48mm (1 7/8") nails spaced 150mm (6") o.c. Fasten face layer of 15.9mm (5/8") CertainTeed Sheathing Type X or GlasRoc® Sheathing Type X vertically or horizontally with 60mm (2 3/8") nails spaced 200mm (8") o.c. CertainTeed's Sustainable Insulation™ 89mm (3 1/2") within cavity. Joints must be offset. Tape and finish interior joints with CertainTeed products. Exterior cladding system applied.

FIRE: cUL U301,  
UL U301

SOUND: NBCC (2010)  
Table A-9.10.3.1.A  
Wall W2a

### FIRE RESISTANCE RATING: 2h

42

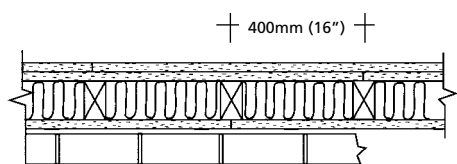

Thickness: 255mm (10")

#### System WXE242

Fasten base layer of 15.9mm (5/8") CertainTeed Type X products vertically or horizontally to interior side of 38mm x 89mm (2 x 4) wood studs with 51mm (2") cement-coated nails spaced 200mm (8") o.c. Fasten face layer of 15.9mm (5/8") CertainTeed or M2Tech® Type X vertically or horizontally with 63mm (2 1/2") cement-coated nails spaced 200mm (8") o.c. Fasten 1 layer of 12.7mm (1/2") CertainTeed Treated Core Sheathing or GlasRoc® Sheathing horizontally to exterior side with 44mm (1 3/4") roofing nails spaced 150mm (6") o.c. CertainTeed's Sustainable Insulation™ 89mm (3 1/2") within cavity. Joints must be offset. Tape and finish interior joints with CertainTeed products. Exterior brick veneer system applied.

FIRE: ULC U302

SOUND: Estimated

\* Note: Any wall as listed in "Wood Stud Partitions" may also be used as an exterior wall, provided it is covered with a sheathing membrane and exterior cladding.

### M2Tech® or GlasRoc® Shaftliner, “J” Track, “C-H, C-T or I” Studs and Shaftliner Framing Installation

Lay out per construction drawings. Secure “J” track as perimeter framing on all sides, top and bottom, with suitable fasteners spaced 600mm (24”) o.c. maximum.

Pre-plan stud layout 600mm (24”) o.c. maximum so the terminal stud on either end will fall 200mm (8”) minimum from the end of the opening.

Erect the first 25mm (1”) M2Tech® or GlasRoc® Shaftliner panel by inserting between the flanges of the “J” track at the top and bottom at one end of the opening. Plumb the panel flush against the web of “J” track sections at the end of the opening.

Secure with 41mm (1 5/8”) type S screws 305mm (12”) o.c. to the flange at the end of the opening, starting 150mm (6”) from the top or bottom. No screws are required at the top or bottom “J” tracks.

Fit a C-H, C-T or I stud to the Shaftliner making sure it’s engaged in the “J” track at the top and bottom.

Erect the adjacent Shaftliner panel by inserting in the top and bottom “J” track and the previously installed stud. Install succeeding studs and Shaftliner panels in this manner to complete the framing. Screws are not required for the top and bottom “J” tracks except at the ends of the opening, as described.

For doors, ducts or other openings install “J” track as perimeter framing.

When required for higher STC ratings, insulation should be friction fitted in the cavity before finishing on the cavity side with 15.9mm (5/8”) CertainTeed Type X products. Resilient channels may be attached horizontally 600mm (24”) o.c. to the studs with 10mm (3/8”) pan head screws at each stud.

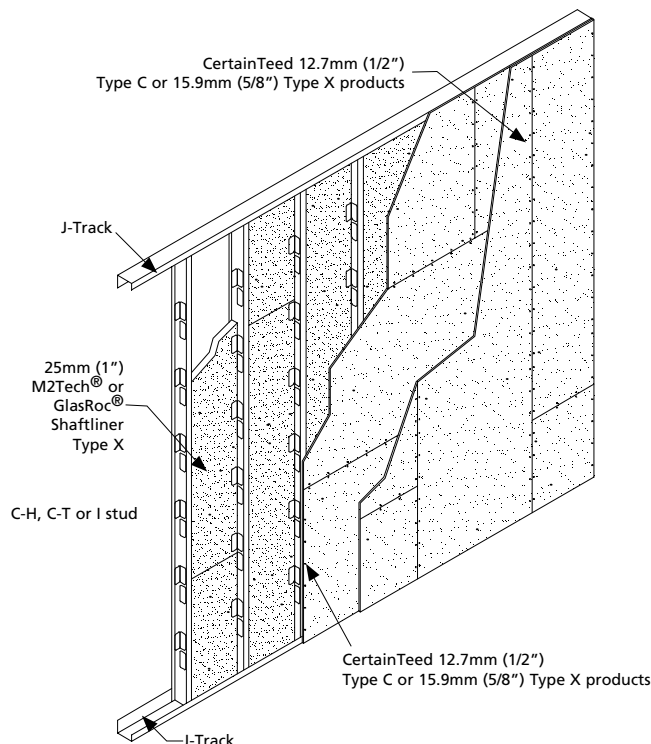

**2-Hour Vertical Shaftwall System**

#### Helpful Hints

1. Use a fastening plate to secure the “J” track whenever fasteners are closer than 100mm (4”) to the edge. Setting the plate at the time of concrete construction will avoid spalling by mechanical fasteners.
2. Pre-cut studs 13mm (1/2”) less than the height of the opening.
3. Pre-cut M2Tech® or GlasRoc® Shaftliner panels 25mm (1”) less than the height of the opening.
4. In structural steel frame construction, install “J” track sections before applying spray-on fireproofing.
5. Items to be anchored to the wall (cabinets, sinks, handrails, etc.) should be fastened to the C-H, C-T or I studs or to plates secured behind or between the layers of 15.9mm (5/8”) CertainTeed Type X products.
6. Joint compounds should be applied at ambient temperatures above 10°C (50°F). Provide adequate ventilation to “drive-off” excess moisture.
7. For acoustic sealant and prevention of air leakage, use a bead of flexible caulking at the perimeter of each wall under the face layer of 15.9mm (5/8”) CertainTeed Type X products and under the 54mm (2 1/8”) flange of “J” track for shaftwall finished on one side.
8. Use type S screws for 25 ga steel framing. Use type S-12 screws for 20 ga or heavier steel framing.



### Recommended procedure for location of Gypsum Board Joints

M2Tech® or GlasRoc® Shaftliner panels may be abutted (spliced) to span the floor-ceiling height. The shorter panel should be at least 600mm (24") long or of sufficient length to engage at least two "I" stud tabs on each panel edge, if I studs are used. Succeeding butt joints between adjoining panels should be spaced no closer than 600mm (24") in elevation.

As an option, and as required in some building code jurisdictions, butt joints in Shaftliner panels may be back blocked in the cavity by screw-attaching a 300mm x 600mm (12" x 24") piece of M2Tech® or GlasRoc® Shaftliner or 15.9mm (5/8") CertainTeed Type X products over the joint to the tabs of the studs.

#### First Layer

The first layer of 15.9mm (5/8") CertainTeed Type X products should be installed with horizontal joints offset a minimum of 300mm (12") from any butt joint in the M2Tech® or GlasRoc® Shaftliner. Any vertical butt joints in the first layer should be staggered in 1200mm (48") increments between succeeding courses. In addition, joints must be offset from joints on opposite side.

#### Second Layer

The second layer of 15.9mm (5/8") CertainTeed Type X products should be installed with vertical joints offset 600mm (24") from any vertical butt joints in the first layer. Any horizontal butt joints in the second layer should be offset a minimum of 300mm (12") from any horizontal joints in the first layer and from any butt joints in the M2Tech® or GlasRoc® Shaftliner. Succeeding butt joints in the second layer between adjoining panels should be spaced no closer than 600mm (24") in elevation.

#### Third Layer, if needed for a 3-Hour Vertical Shaftwall System

The third layer of 15.9mm (5/8") CertainTeed Type C products should be installed with vertical joints offset 600mm (24") from any vertical joints in the second layer. Any horizontal butt joints in the third layer should be offset a minimum of 150mm (6") from any horizontal joint in the previous layer, including M2Tech® Shaftliner. Succeeding butt joints in the third layer between adjoining panels should be spaced no closer than 300mm (12") in

elevation.

### Section Details

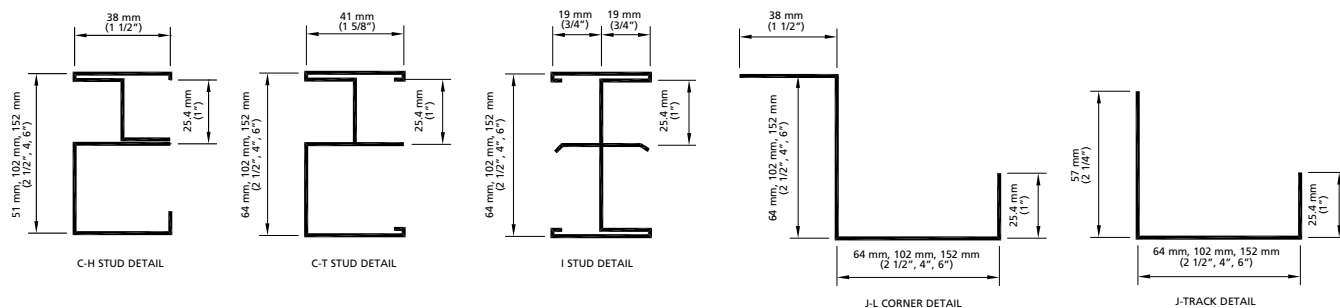

# SHAFTWALLS

## Non-Load Bearing

SOUND  
TRANSMISSION  
CLASS (STC)

CONSTRUCTION

DESCRIPTION

DESIGN NUMBER/  
TEST REPORTS

### FIRE RESISTANCE RATING: 1h

42

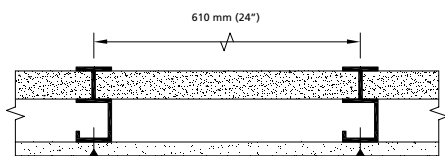

Thickness: 80 mm (3 1/8")  
Weight: 32 kg/m<sup>2</sup> (6.5 lb/ft<sup>2</sup>)

#### System WSD142

**Vertical Shaftwall System** *Finished one side*  
25 mm (1") M2Tech® or GlasRoc® Shaftliner gypsum boards are inserted between 64 mm (2 1/2"), 102 mm (4") or 152 mm (6") C-H, C-T or I Studs. A single layer of any 15.9 mm (5/8") CertainTeed Type X product is applied vertically or horizontally, on open stud-face side with 25 mm (1") Type S screws spaced 300 mm (12") on center at all locations except the vertical board joint in horizontal applications where the screws should be 200mm (8") on center. Exposed joints and screwheads are to be finished with CertainTeed Finishing System.

FIRE: ULC W446,  
WHI-651-0306.1  
(Horizontal application)

SOUND: Intertek  
3123470EEV,  
(64mm stud)  
STC 42 with  
CertainTeed's Sustainable  
Insulation™

### FIRE RESISTANCE RATING: 2h

50

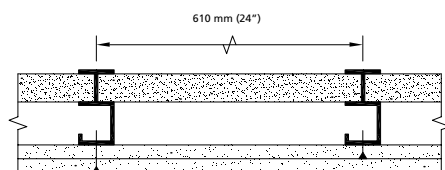

Thickness: 95 mm (3 3/4")  
Weight: 44 kg/m<sup>2</sup> (9 psf)

#### System WSD250

**Vertical Shaftwall System** *Finished one side*  
25 mm (1") M2Tech® or GlasRoc® Shaftliner gypsum boards are inserted between 64 mm (2 1/2"), 102 mm (4") or 152 mm (6") C-H, C-T or I Studs. Two layers of any 12.7 mm (1/2") CertainTeed Type C product or any 15.9 mm (5/8") CertainTeed Type X product are applied to one side, with the base layer applied vertically or horizontally to the open-stud-face of framing studs with 25 mm (1") Type S buglehead screws spaced 600 mm (24") o.c. The second layer is placed vertically or horizontally (opposite of base layer) over the base layer and fastened using 41 mm (1 1/8") No. 6 Type S screws spaced 300 mm (12") on center. Exposed joints and screwheads are to be finished with CertainTeed Finishing system.

FIRE: ULC W446

SOUND: Intertek  
3123470EEV STC 50  
with 15.9 mm (5/8")  
CertainTeed Type X  
products, resilient channel  
and CertainTeed's  
Sustainable Insulation™

50

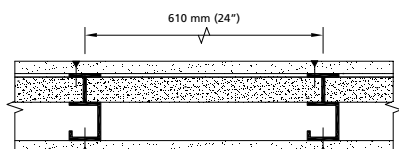

Thickness: 95 mm (3 3/4")  
Weight: 44 kg/m<sup>2</sup> (9 psf)

#### System WSD250a

**Vertical Shaftwall System** *Finished both sides*  
25 mm (1") M2Tech® or GlasRoc® Shaftliner gypsum boards are inserted between 64 mm (2 1/2"), 102 mm (4") or 152 mm (6") C-H, C-T or I Studs. A single layer of any 12.7 mm (1/2") CertainTeed Type C product or any 15.9 mm (5/8") CertainTeed Type X product is applied vertically on both sides, parallel to framing, with 25 mm (1") Type S screws spaced 300 mm (12") o.c. Joints are staggered or offset. Exposed joints and screwheads are to be finished with CertainTeed Finishing System.

FIRE: ULC W446

SOUND: Intertek  
3123470EEV  
STC 50 with resilient  
channel and  
CertainTeed's Sustainable  
Insulation™

# SHAFTWALLS

## Non-Load Bearing

SOUND TRANSMISSION CLASS (STC)

CONSTRUCTION

DESCRIPTION

DESIGN NUMBER/TEST REPORTS

### FIRE RESISTANCE RATING: 2h (continued)

54

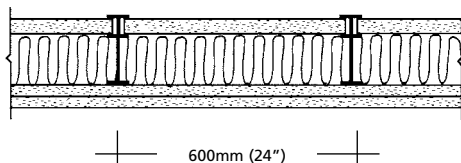

Thickness: 133mm (5 1/4")  
Weight: 47 kg/m<sup>2</sup> (9.7 lb/ft<sup>2</sup>)

#### System WSD254 Finished one side.

15.9mm (5/8") CertainTeed Type X products or 12.7 mm (1/2") CertainTeed Type C products, 2 layers, corridor side. CertainTeed's Sustainable Insulation™ 89mm (3 1/2") within cavity.

Install 101mm (4") J-track, C-H, C-T or I studs and M2Tech® or GlasRoc® Shaftliner panels. Fasten base layer horizontally or vertically to corridor side with 25mm (1") screws spaced 610mm (24") o.c. starting 75mm (3") from the top of each stud. Fasten face layer opposite of base layer with 41mm (1 5/8") screws spaced 610mm (24") o.c. staggered 300mm (12") from base layer screws starting 150mm (6") from top of each stud. Screws are not required along top or bottom tracks. Joints must be offset. Tape and finish corridor joints with CertainTeed products.

FIRE: ULC W446

SOUND: NRC TL-94-037

### FIRE RESISTANCE RATING: 3h

50

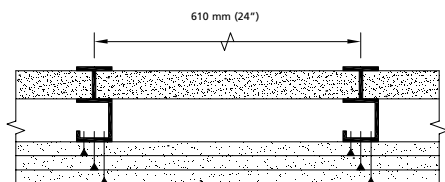

Thickness: 111 mm (4 3/8")  
Weight: 59 kg/m<sup>2</sup> (12 psf)

#### System WSD350

##### Vertical Shaftwall System Finished one side

25 mm (1") M2Tech® Shaftliner gypsum boards are inserted between 64mm (2 1/2"), 102 mm (4") or 152mm (6") C-H, C-T or I Studs. Three layers of any 15.9 mm (5/8") CertainTeed Type C product are installed on the open stud-face with the base layer installed vertically with 25 mm (1") Type S screws spaced 600 mm (24") o.c. Remaining layers applied horizontally or vertically, middle layer with 41 mm (1 5/8") and face with 57 mm (2 1/4") Type S screws. Screws offset 150 mm (6") from layer below. When board is applied horizontally, 38 mm (1 1/2") Type G screws to be installed at the center of each stud cavity, 38 mm (1 1/2") from both sides of the horizontal joint. Exposed joints and screwheads finished with CertainTeed Finishing System.

FIRE: ULC W446

SOUND: Intertek  
3123470EEV  
STC 50 with resilient channel and CertainTeed's Sustainable Insulation™

52

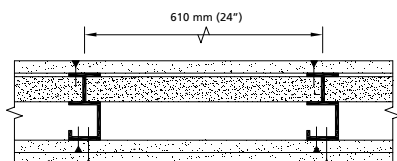

Thickness: 111 mm (4 3/8")  
Weight: 59 kg/m<sup>2</sup> (12 psf)

#### System WSD350a

##### Vertical Shaftwall System Finished two sides

25 mm (1") M2Tech® Shaftliner gypsum boards are inserted between 64 mm (2 1/2"), 102 mm (4") or 152 mm (6") C-H, C-T or I Studs. A single layer of any 15.9 mm (5/8") CertainTeed Type C product is installed on top of M2Tech® Shaftliner. Two layers of any 15.9 mm (5/8") CertainTeed Type C product are installed on the open stud-face. Base layer is installed vertically with 25 mm (1") Type S screws spaced 600 mm (24") o.c. Face layer is applied horizontally or vertically with 41mm (1 5/8") Type S screws. Screws offset 150 mm (6") from layer below. When board is applied horizontally, 38 mm (1 1/2") Type G screws to be installed at the center of each stud cavity, 38 mm (1 1/2") from both sides of the horizontal joint. Exposed joints and screwheads finished with CertainTeed Finishing System.

FIRE: ULC W446

SOUND:  
NGC Testing 2006038  
STC 52 with CertainTeed's Sustainable Insulation™

# SHAFTWALL HORIZONTAL SYSTEMS

## Non-Load Bearing

CONSTRUCTION

DESCRIPTION

DESIGN NUMBER/  
TEST REPORTS

**FIRE RESISTANCE RATING: 1h**

35

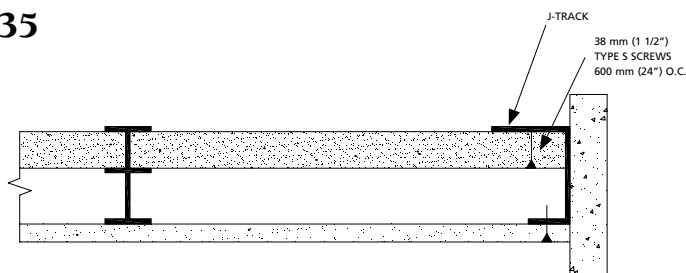

Thickness: 80 mm (3 1/8")  
Weight: 31 kg/m<sup>2</sup> (6.5 psf)

### System WSD135

#### Horizontal Ceiling System *For corridors.*

25 mm (1") M2Tech® or GlasRoc® Shaftliner gypsum boards are inserted between 64 mm (2 1/2"), 102 mm (4") or 152 mm (6") C-H, C-T or I Studs. A single layer of any 15.9 mm (5/8") CertainTeed Type X product is applied at right angles to the C-H, CT or I Studs, with 25 mm (1") Type S screws spaced 300 mm (12") o.c.

FIRE: ITS (WHI)  
CTG/CC 60-01

SOUND: Intertek  
3123470EEV  
64 mm (2 1/2") studs

**FIRE RESISTANCE RATING: 2h**

40

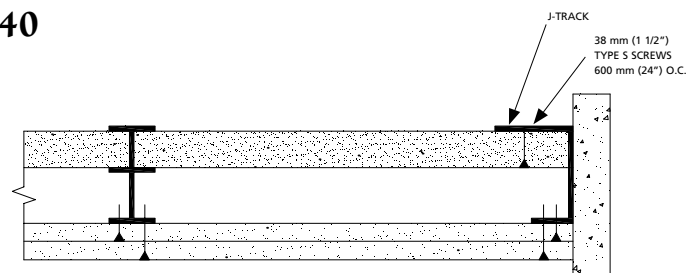

Thickness: 89 mm (3 1/2")  
Weight: 39 kg/m<sup>2</sup> (9 psf)

### System WSD240

#### Horizontal Ceiling System *For corridors.*

25 mm (1") M2Tech® or GlasRoc® Shaftliner gypsum boards are inserted between 64 mm (2 1/2"), 102 mm (4") or 152 mm (6") C-H, C-T or I Studs. Two layers of any 12.7 mm (1/2") CertainTeed Type C product are installed on the open stud face with the first layer installed at right angles to the C-H, CT or I Studs with 25 mm (1") Type S screws spaced at 300 mm (12") o.c., and the second layer installed parallel to the C-H, CT or I Studs with 38 mm (1 1/2") Type S screws at 600 mm (24") o.c.

FIRE: ITS (WHI)  
CTG/CC 120-01

SOUND: Intertek  
3123470EEV  
64 mm (2 1/2") studs

# SHAFTWALL HORIZONTAL SYSTEMS

## Non-Load Bearing

CONSTRUCTION

DESCRIPTION

DESIGN NUMBER/  
TEST REPORTS

**FIRE RESISTANCE RATING: 2h**

40

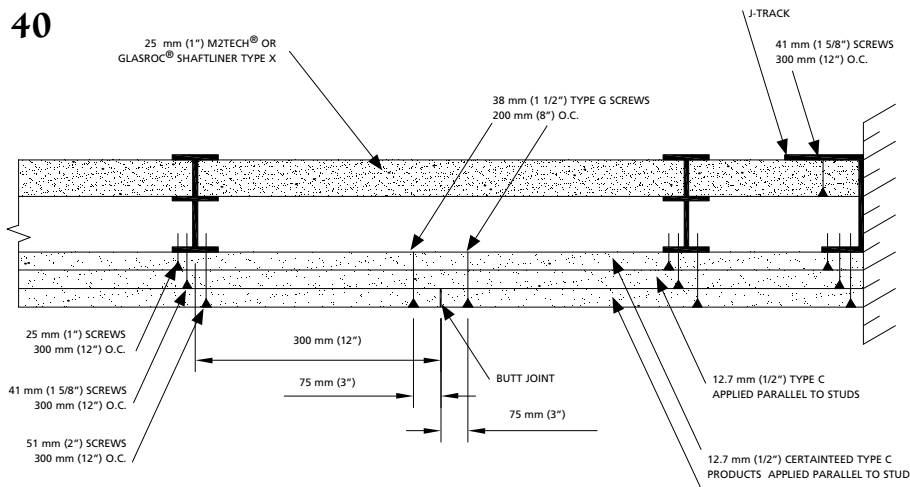

**System WSD240a**  
**Horizontal Membrane**  
**for Duct Enclosure**  
*For corridors, ducts,*  
*enclosures, etc.*

FIRE: ITS (WHI)  
CTG/CC 120-03

SOUND: Intertek  
3123470EEV

Thickness: 102 mm (4")  
Weight: 54 kg/m<sup>2</sup> (11 psf)

**SPANS OF HORIZONTAL MEMBERS (CEILINGS OVER CORRIDORS OR STAIRWAYS)**  
**SHOULD NOT EXCEED SPANS SPECIFIED BY STUD MANUFACTURER.**  
**C-H, C-T, OR I STUDS ARE PERMISSIBLE.**

**System WSD200**

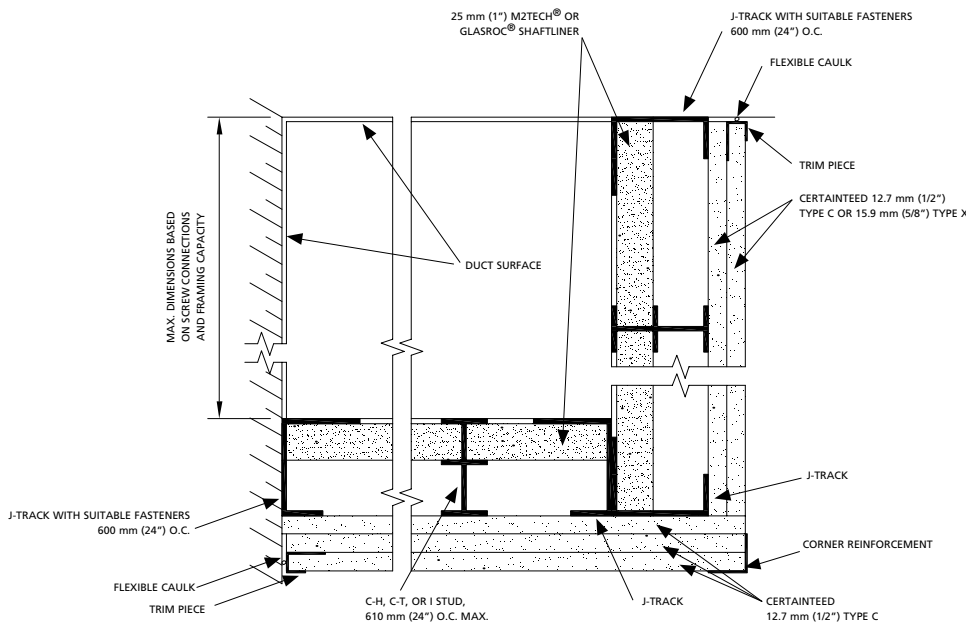

HORIZONTAL DUCT ENCLOSURE

# SHAFTWALLS

## Vertical Assembly Details

### DETAILS – FINISHED ONE SIDE

**OUTSIDE CORNER**

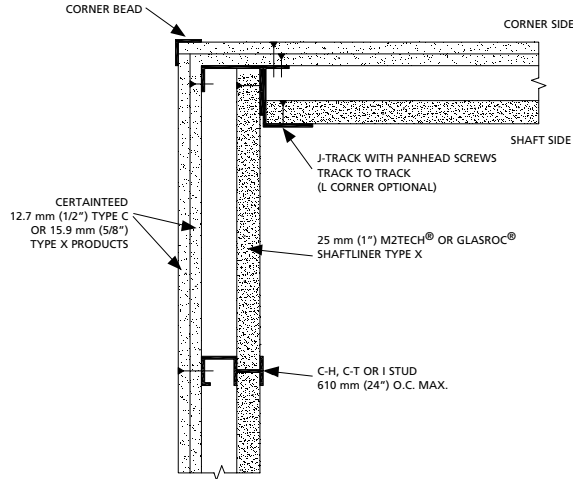

**INSIDE AND OUTSIDE CORNER**

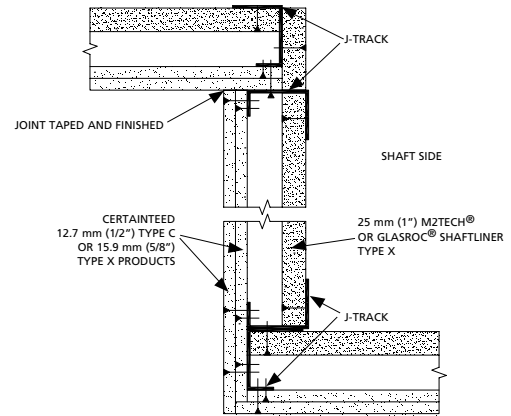

**TYPICAL START/END OF WALL**

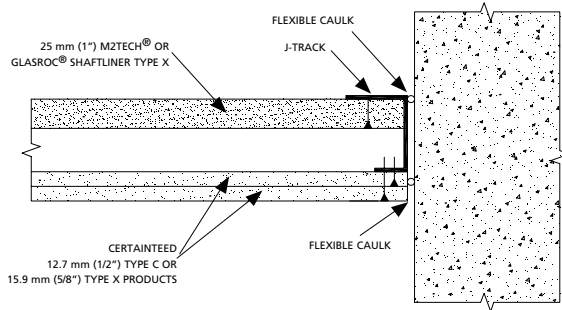

**ALTERNATE END OF WALL SECTION**

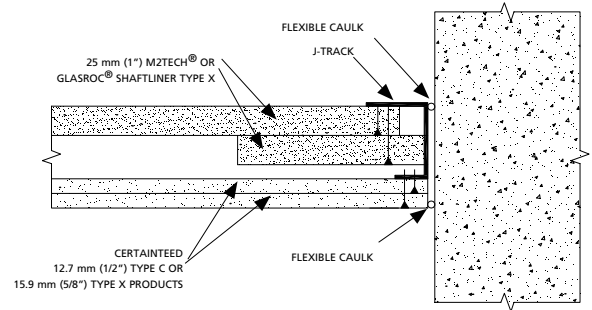

**WALL INTERSECTION ON SHAFTLINER SIDE**

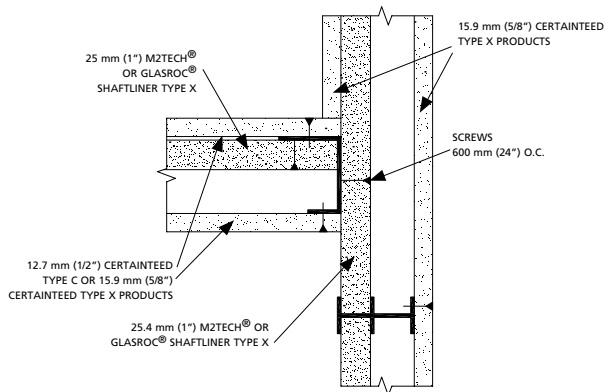

**SEPARATION WALL INTERSECTION ON FINISHED SIDE**

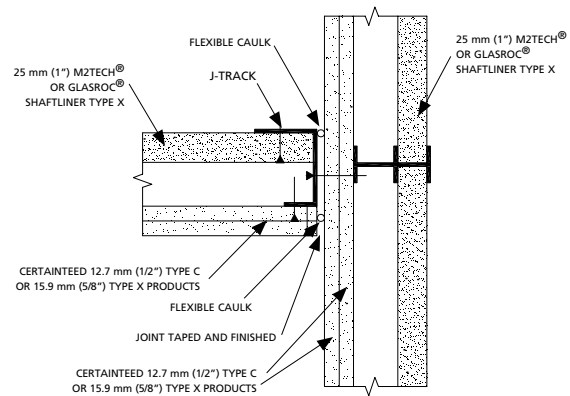

# SHAFTWALLS

## Vertical Assembly Details

### DETAILS – FINISHED BOTH SIDES

#### ABUTMENT TO MASONRY

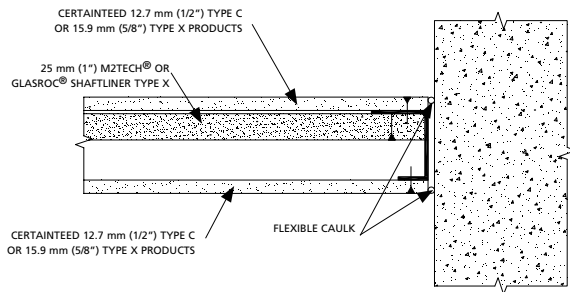

#### WALL INTERSECTION ON CAVITY SIDE

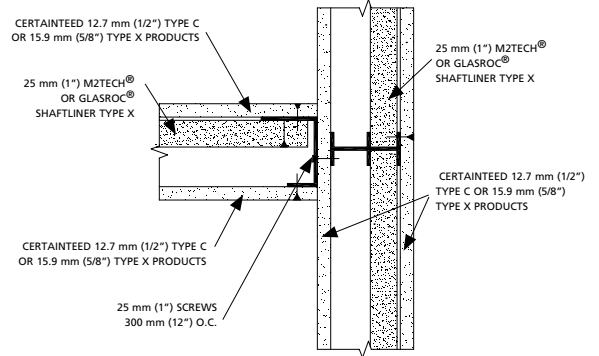

#### INSIDE AND OUTSIDE CORNER

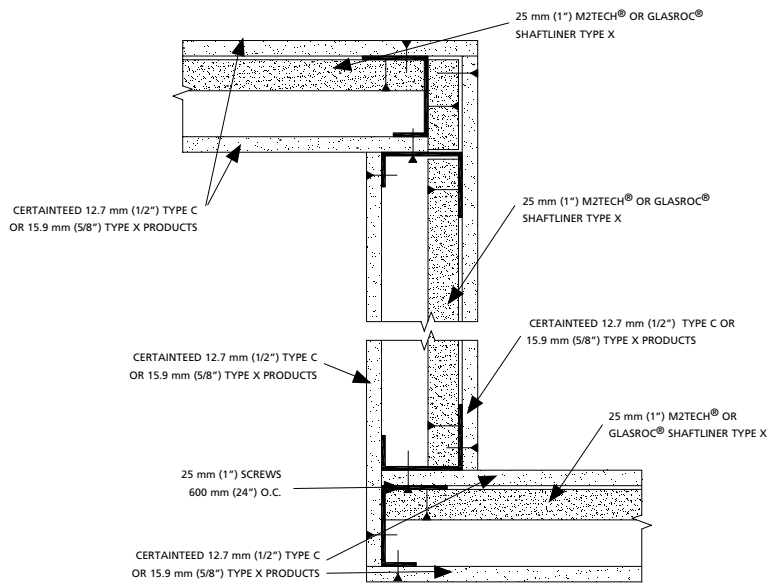

# SHAFTWALLS

## Vertical Assembly Details

**SHAFTWALL TO BEAM**

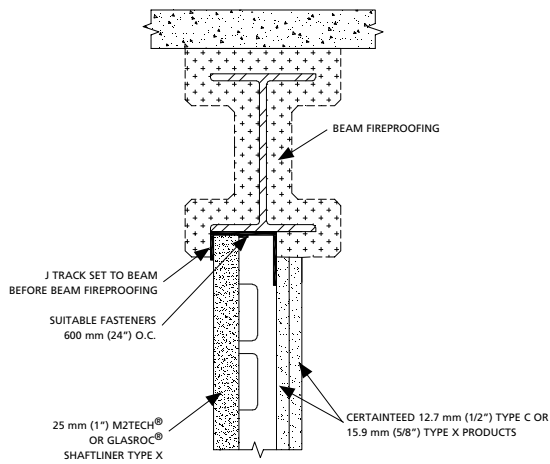

**SHAFTWALL OFFSET FROM BEAM**

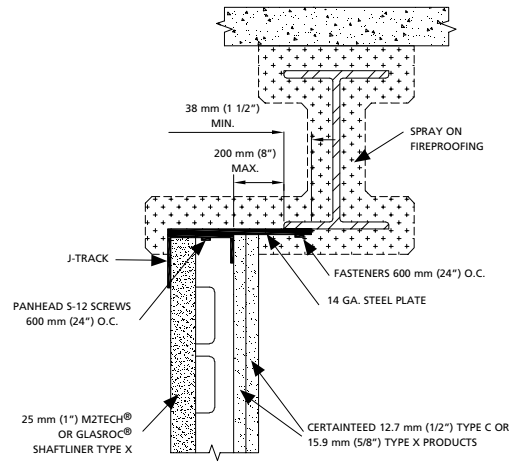

**SHAFTWALL OFFSET FROM DECK**

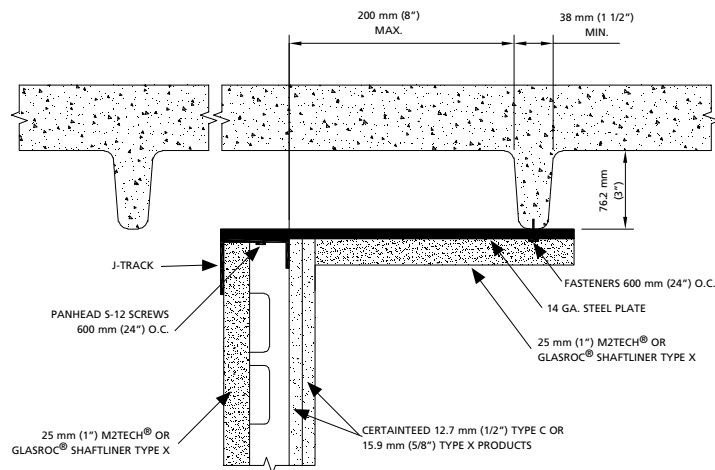

**CORNER COLUMN BYPASS**

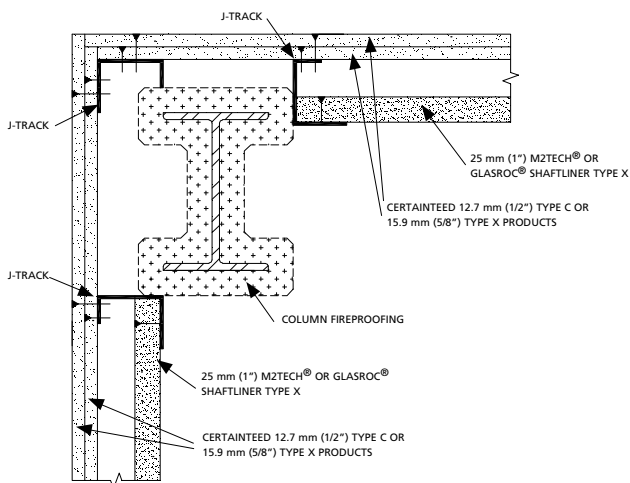

**BYPASS OF LARGE COLUMNS**

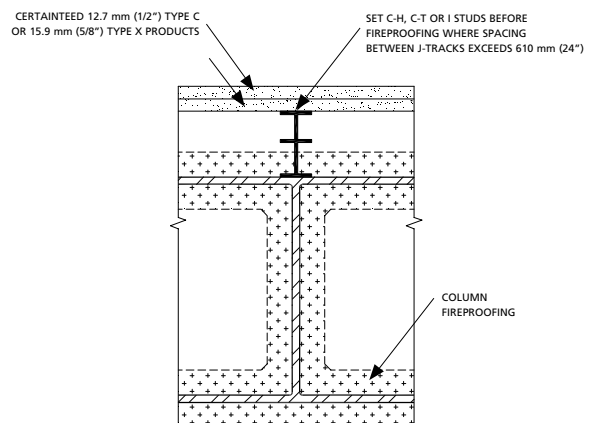



# SHAFTWALLS

## Vertical Assembly Details

### TOP AT BEAM AND FLOOR BYPASS

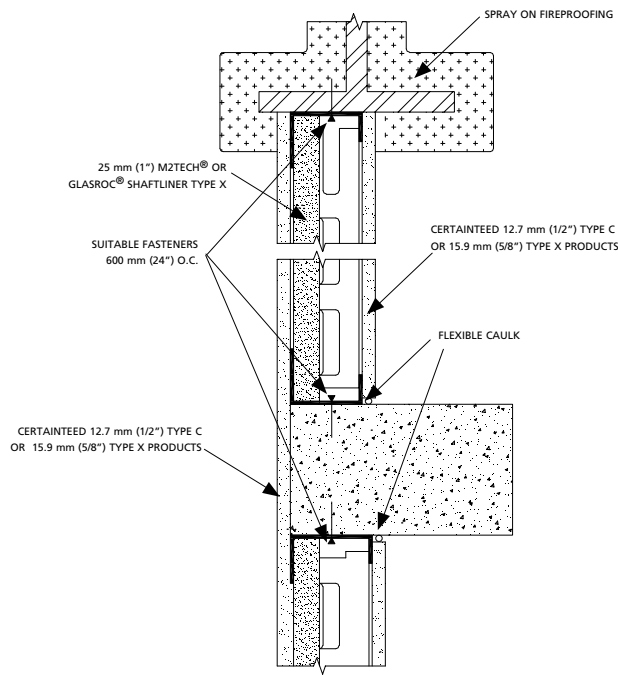

### SHAFT CANT

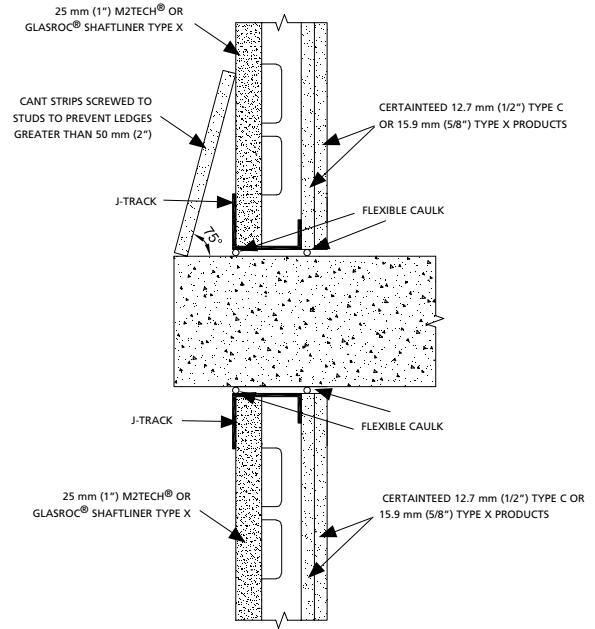

### HAND RAIL ATTACHMENT DETAILS

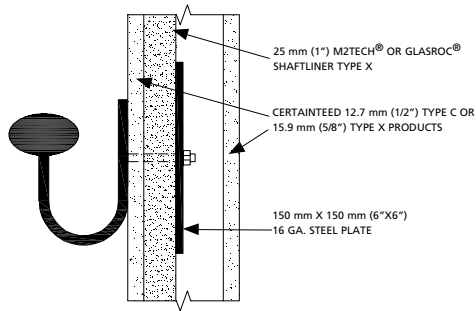

HEAVY

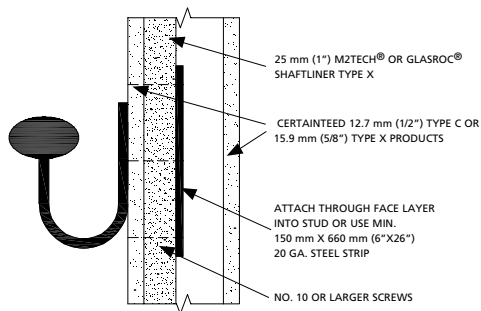

MEDIUM

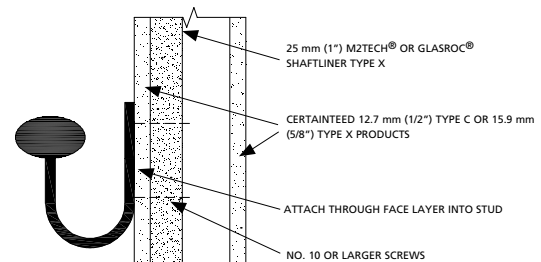

LIGHT

# SHAFTWALLS

## Vertical Assembly Details

### SHAFTWALL ELEVATOR ELECTRICAL CONTROL LAYOUT

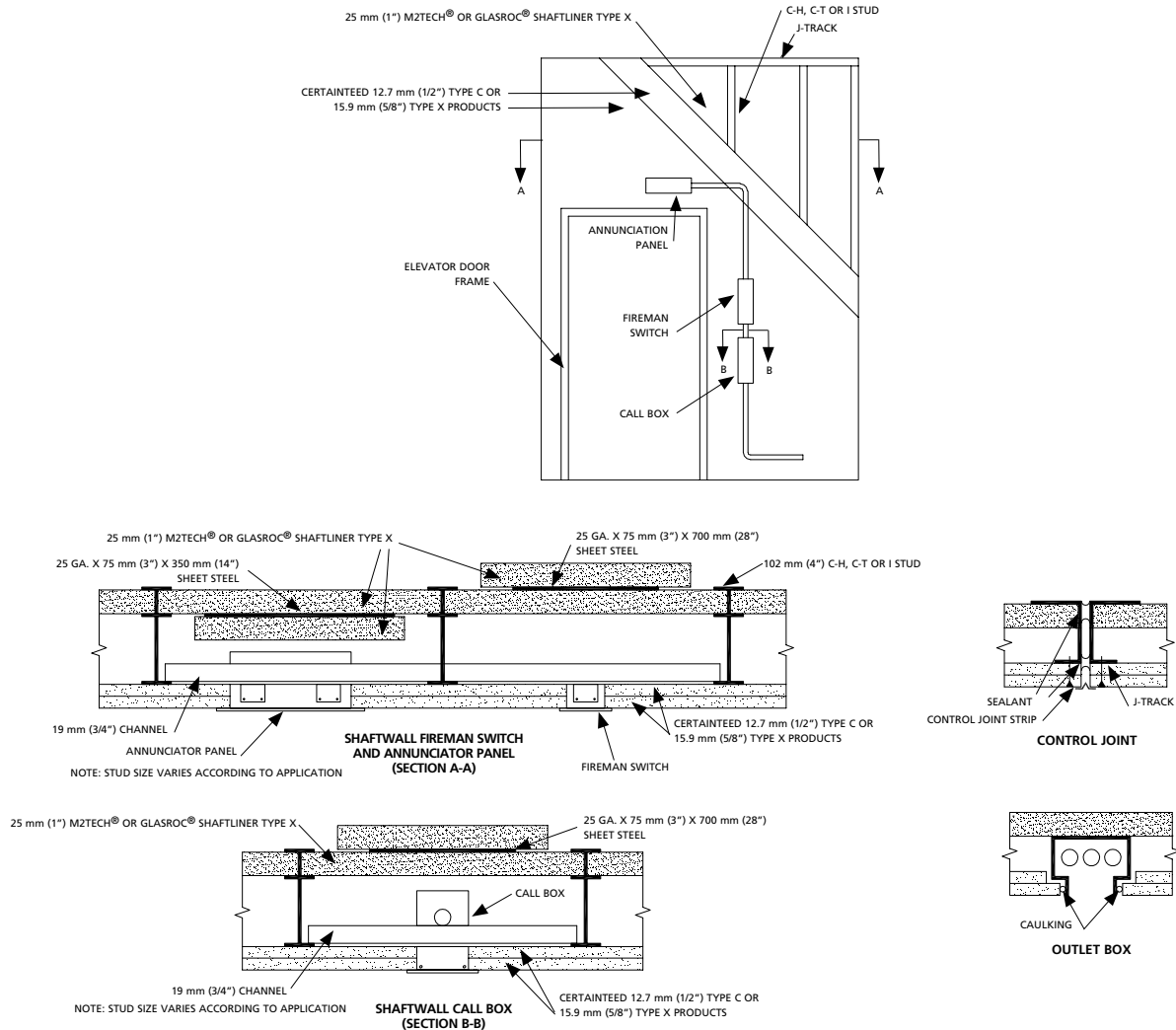

### MAIL CHUTE

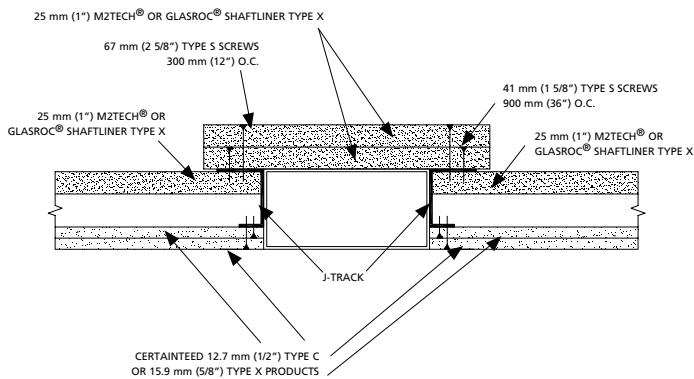

### CHASE WALL

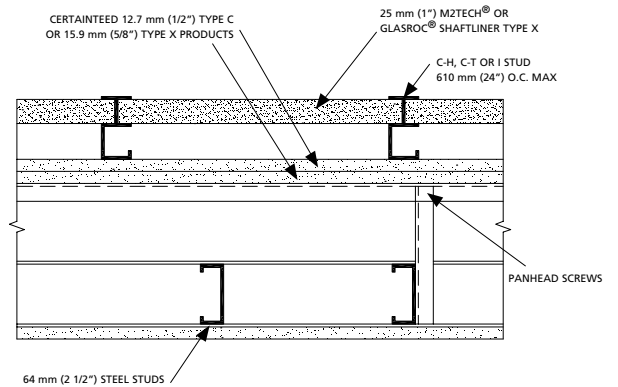

# SHAFTWALLS

## Vertical Assembly Details

ILLUSTRATED WITH 2 HR. RATED ASSEMBLY

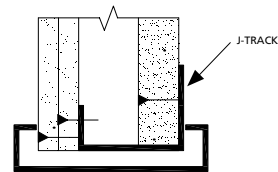
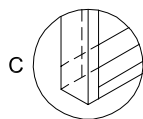
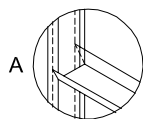
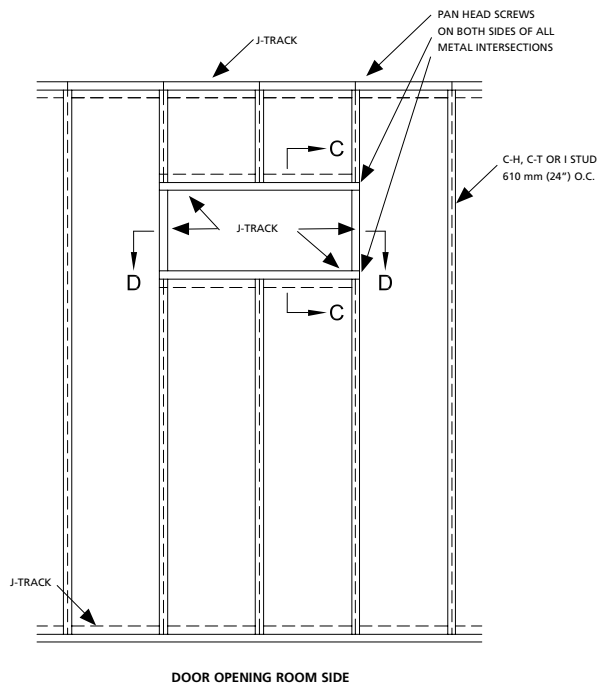
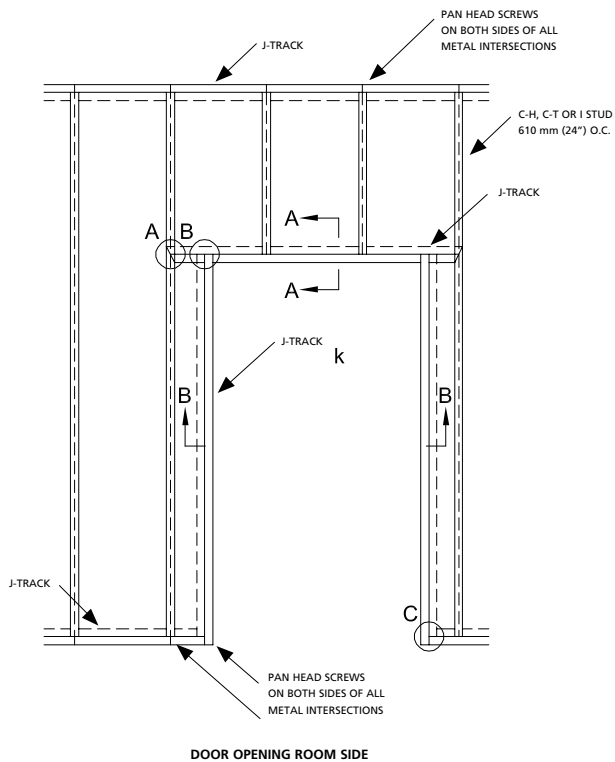

HEADER SECTION AA

JAMB TRIM GROUTED IN PLACE AND/OR ATTACHED TO J-TRACK WITH JAMB ANCHOR CLIPS

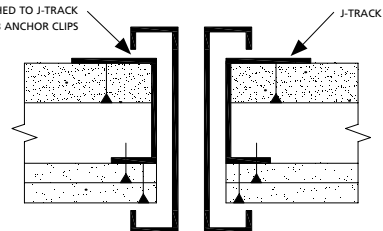

CROSS SECTION B-B

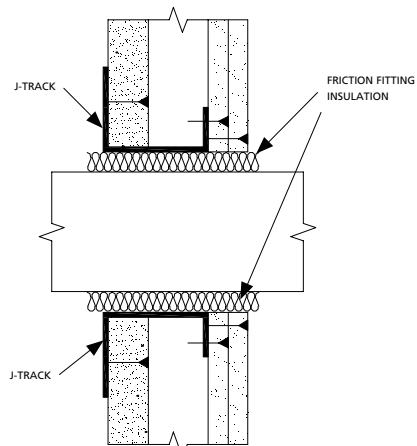

DUCT SECTION C-C

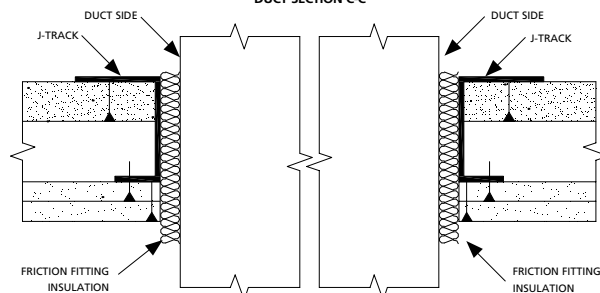

DUCT SECTION D-D

NOTE:  
CLEARANCE OPENINGS AND ATTACHMENTS  
DETAILS SHOULD BE AS PER FIRE DAMPER  
MANUFACTURER'S INSTALLATION REQUIREMENTS

# SHAFTWALLS

## Vertical Assembly Details

### ONE HOUR DETAILS

#### ELEVATOR DOOR FRAMING

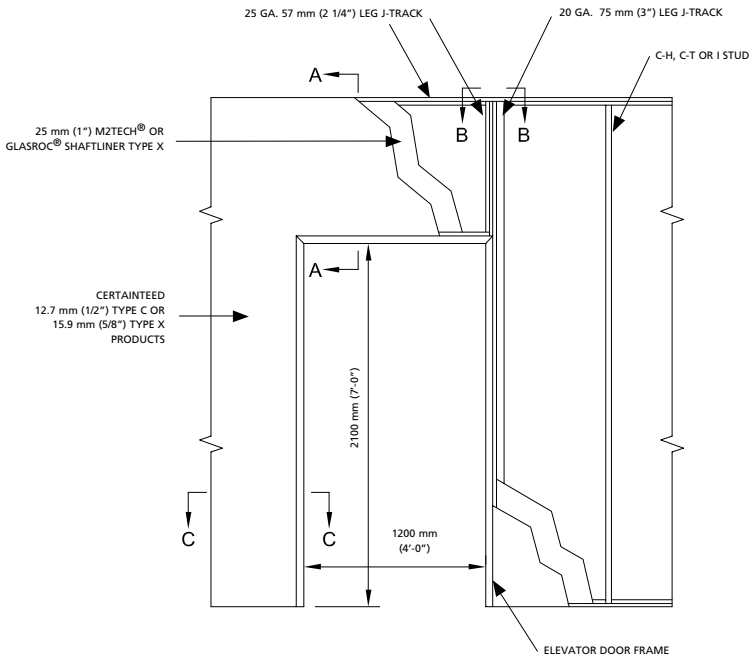

#### ELEVATOR DOOR HEAD

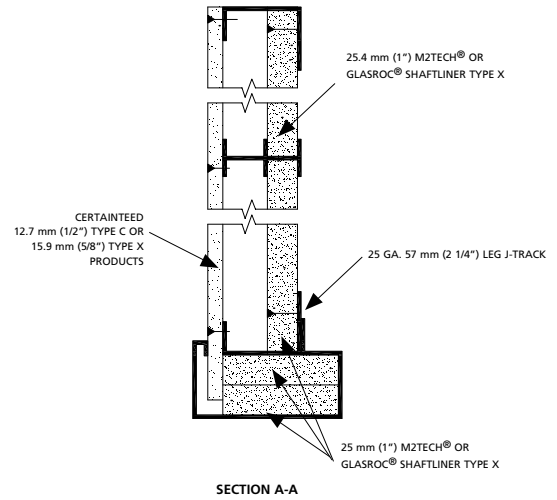

#### J-TRACK FRAMING ABOVE DOOR

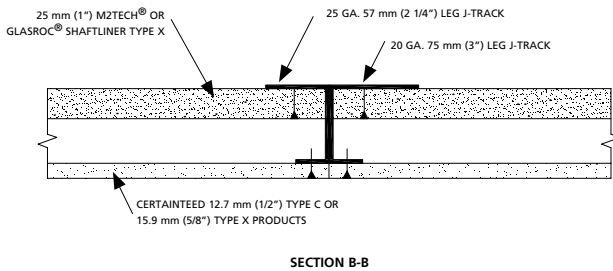

#### ELEVATOR DOOR JAMB

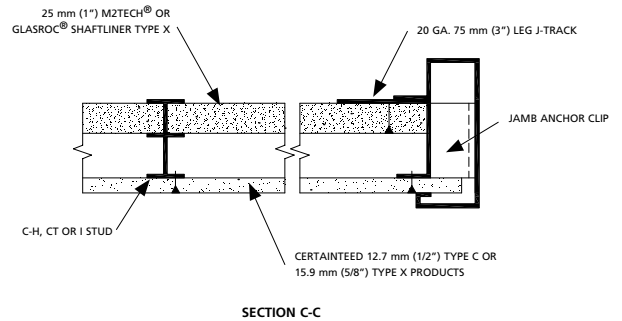

# SHAFTWALLS

## Vertical Assembly Details

### TWO HOUR DETAILS

#### ELEVATOR DOOR FRAMING

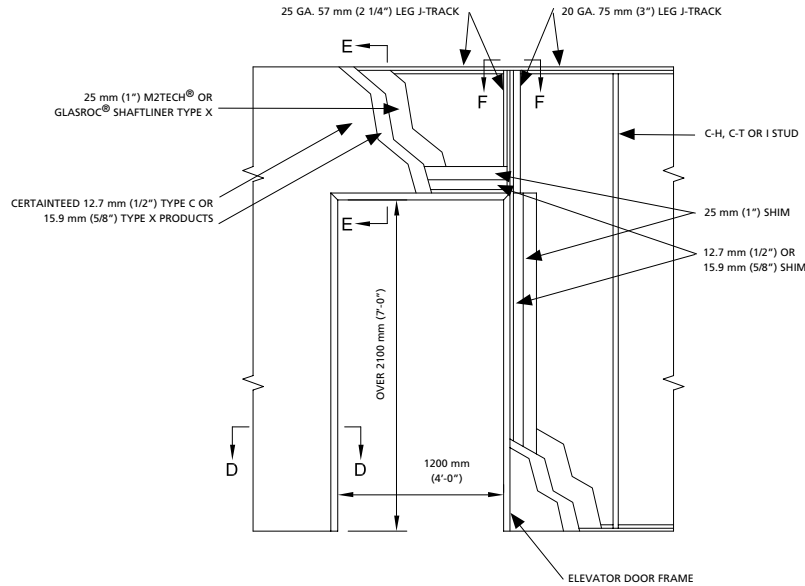

#### ELEVATOR DOOR JAMB

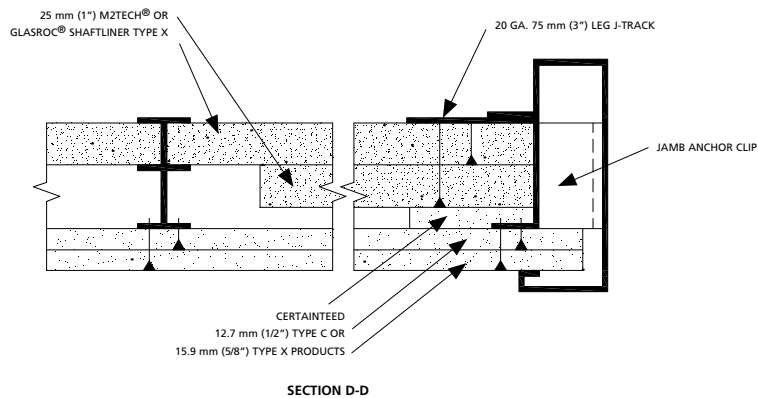

#### ELEVATOR DOOR HEAD

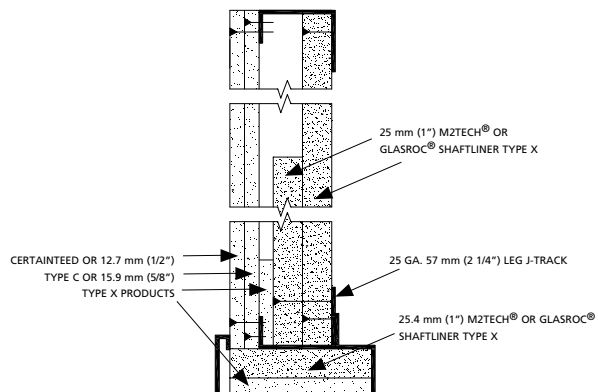

#### J-TRACK FRAMING ABOVE ELEVATOR DOOR

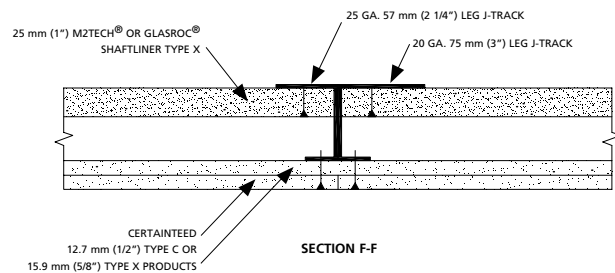

# AREA SEPARATION FIREWALLS

---

## AREA SEPARATION FIREWALLS

M2Tech® or GlasRoc® Shaftliner gypsum boards are used in conjunction with other CertainTeed gypsum board products in Area Separation Firewalls. Area Separation Firewalls are solid type separation walls assembled using 25mm (1") M2Tech® or GlasRoc® Shaftliner gypsum boards, metal framing and any minimum 12.7mm (1/2") CertainTeed Gypsum Boards approved for wall construction for the interior finish. The firewall is easily stacked, floor to floor, allowing progressive construction.

Breakaway aluminum clips are used to attach the interior wall to adjacent structural metal framing and provide lateral support. When one side is exposed to fire, the clips will soften and release if the burning unit collapses. The clips on the non-fire side are protected by the area separation wall and will continue to support the firewall. The Area Separation Firewall will remain intact to protect neighboring spaces. Area Separation Firewalls are easier and faster to construct, lighter weight, and take up less space than masonry wall systems.

### Installation

Steel framing and installation of 25mm (1") M2Tech® or GlasRoc® Shaftliner gypsum boards for solid type Area Separation Firewalls are used as the common wall of one unit. An Area Separation Firewall can be constructed by following these steps before continuing to frame the adjacent unit.

1. Attach 51mm (2") wide C-Track to slab at bottom of wall using suitable fasteners at a maximum of 600mm (24") o.c. Allow a minimum 19mm (3/4") space from wood stud framing on each side of the area separation firewall. As an alternate to the 19mm (3/4") air space the steel components are permitted to be covered with either (a) 150mm (6") wide batten strips of 12.7mm (1/2") gypsum panel screw attached to the framing with 25mm (1") Type S drywall screws or (b) 25mm (1") mineral wool fiber insulation. Space ends of adjacent sections of C-Track a minimum of 6mm (1/4") apart. When required, use an approved acoustical sealant to caulk around the perimeter of wall sections.
2. Install vertical C-Track at the beginning of the wall and support as needed.
3. Insert two sections of 25mm (1") M2Tech® or GlasRoc® Shaftliner gypsum boards in the bottom channel and plumb to vertical C-Track. Make sure the first two shaftliner panels are seated all the way into the floor and vertical C-Tracks and that the edges are flush. Insert an H-Stud into the floor C-Track and engage the H-Stud legs over the long edges of the shaftliner panels.
4. Install the next 25mm (1") M2Tech® or GlasRoc® Shaftliner gypsum boards vertically into the H-Studs. Continue wall as needed by placing H-Studs between the proceeding panels every 610mm (24") for the length of the wall and enclose the end boards with vertical C-Track.
5. Cap the wall assembly before continuing higher using C-Track fastened to the H-Studs on alternate sides with 10mm (3/8") Type S screws. A second C-Track for the next row of shaftliner panels is then placed back to back with end joints staggered at least 300mm (12") o.c. and fastened with double 10mm (3/8") Type S screws at ends and 600mm (24") o.c.
6. Attachment Clips: Aluminum angle; 1.6mm (0.063") thick, minimum 51mm (2") and 57mm (2 1/4") legs. Clips are secured with Type S screws 10mm (3/8") long to H-Studs and with Type W screws 32mm (1 1/4") long to wood framing through holes provided in the clip. Clips should be attached to each H-Stud per the following schedule:
  - For area separation walls up to 7m (23') high, clip placement should be:
    - i. Clips are required to be spaced a maximum of 3m (10') o.c. vertically between wood framing and H-Studs.
  - For area separation walls greater than 7m (23') high and up to 13.4m (44') high, clip placement should be:
    - i. The lower 6.1m (20') requires clips to be spaced a maximum of 1.5m (5') o.c. vertically between the wood framing and the H-Studs
    - ii. The upper section of the wall (6.1m to 13.4m) (20' to 44') requires the clips to be spaced a maximum of 3m (10') o.c. vertically between the wood framing and the H-Studs.

# AREA SEPARATION FIREWALLS

- For area separation walls greater than 13.4m (44') high and up to 20.7m (68') high, clip placement should be:
  - i. The lower 7.3m (24') requires clips to be spaced a maximum of 1m (40") o.c. vertically between the wood framing and the H-Studs
  - ii. The next 6.1m (20') section requires clips to be spaced a maximum of 1.5m (5') o.c. vertically between the wood framing and the H-Studs.
  - iii. The upper section of the wall 13.4m to 20.7m (44' to 68') requires the clips to be spaced a maximum of 3m (10') o.c. vertically between the wood framing and the H-Studs.
- 7. Cap the top of the assembly with 51mm (2") C-Track and protect the entire installation from moisture. The Area Separation Firewall may either extend to the top of a parapet wall or terminate at the underside of the roof deck.

## Interior Finish Wall

8. Wood Studs – Nominal 38mm x 89mm (2" x 4") with a maximum spacing of 610mm (24") o.c. Studs are cross-braced at mid-height where necessary for clip attachment. Ensure a minimum 19mm (3/4") separation between wood framing and Area Separation Firewall.
9. Insulation (Optional) – CertainTeed's Sustainable Insulation™ (Optional) – CertainTeed CertaSound™ NoiseReducer™, Sustainable Insulation™, or equivalent, installed between wood studs to meet listed STC performance.
10. CertainTeed gypsum boards, minimum 12.7mm (1/2") thick, 1220mm (4') wide, applied either horizontally or vertically. Gypsum boards are attached to studs with 32mm (1 1/4") long steel drywall nails or 32mm (1 1/4") Type W drywall screws spaced 200mm (8") o.c. Vertical joints are located over studs. Joints and fasteners are finished with CertainTeed Finishing system.

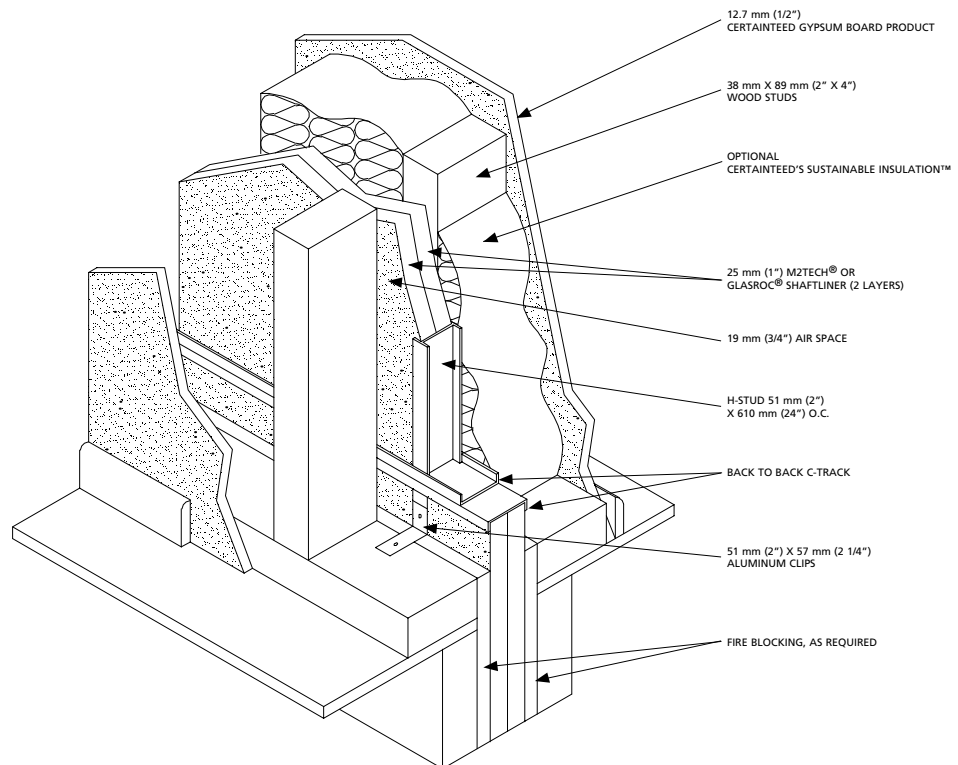

# AREA SEPARATION FIREWALLS

## Non-Load Bearing

SOUND TRANSMISSION CLASS (STC)

CONSTRUCTION

DESIGN NUMBER/TEST REPORTS

**FIRE RESISTANCE RATING: 2h**

**57** System WAH257

**EXPOSED TO FIRE FROM AREA SEPARATION FIREWALL SIDE ONLY**

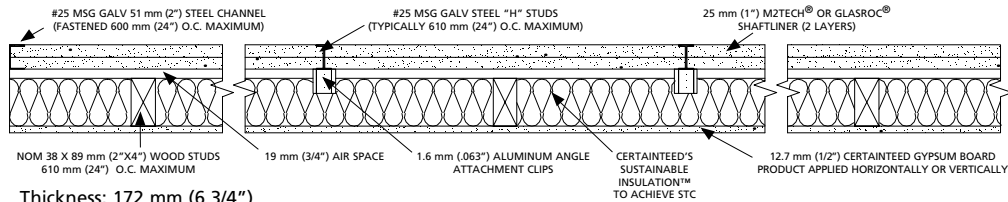

Thickness: 172 mm (6 3/4")  
Weight: 49 kg/m2 (10 psf)

FIRE: ULC W311  
ITS Report No. 100260628SAT-006A, 006B

SOUND:  
RAL-TL00-177

**61** System WAH261

**EXPOSED TO FIRE FROM EITHER SIDE**

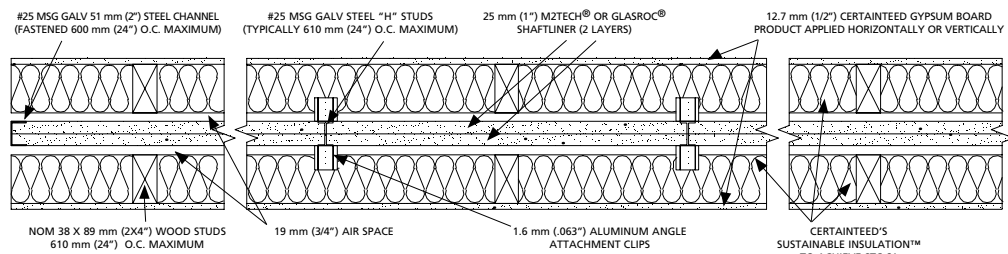

Thickness: 292 mm (11 1/2")  
Weight: 63 kg/m2 (13 psf)

FIRE: ULC W311  
ITS Report No. 100260628SAT-006A, 006B

SOUND:  
RAL-TL00-176

**TYPICAL INSTALLATION DETAILS**

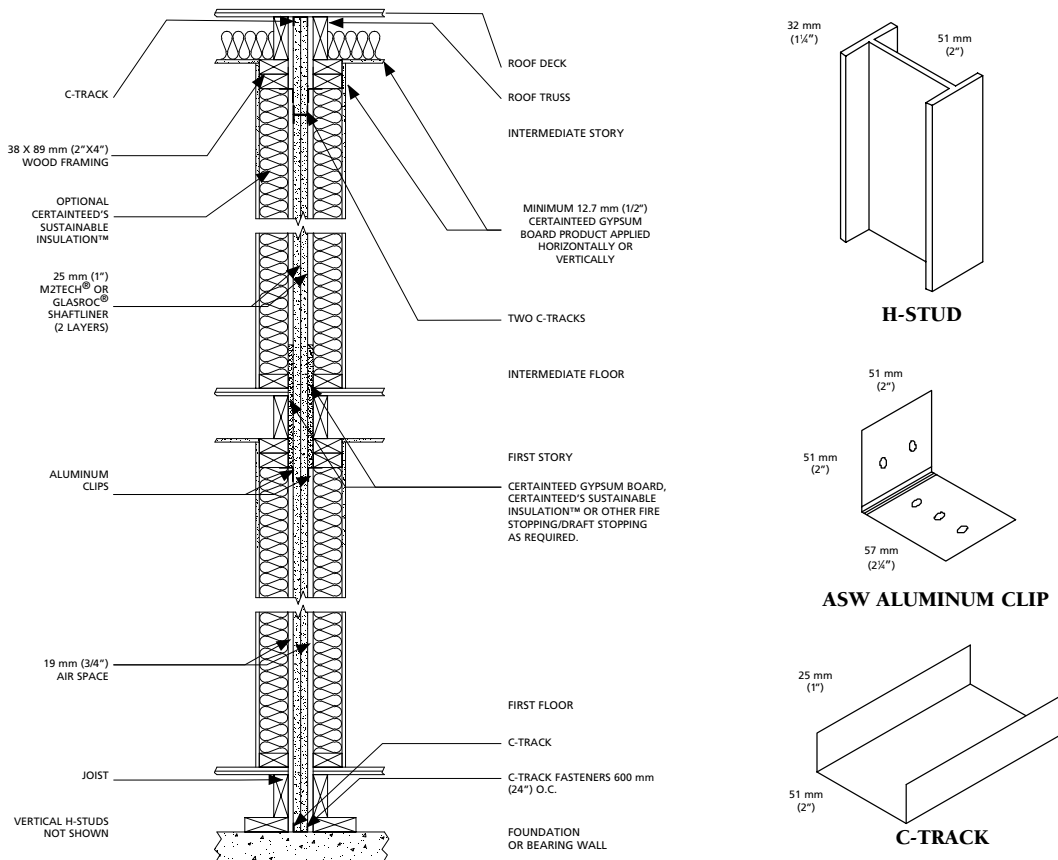



# AREA SEPARATION FIREWALLS

## Non-Load Bearing

**FIRE RESISTANCE RATING: 2h**

### INTERMEDIATE FLOOR INTERSECTION LOCATION OF ASW CLIPS

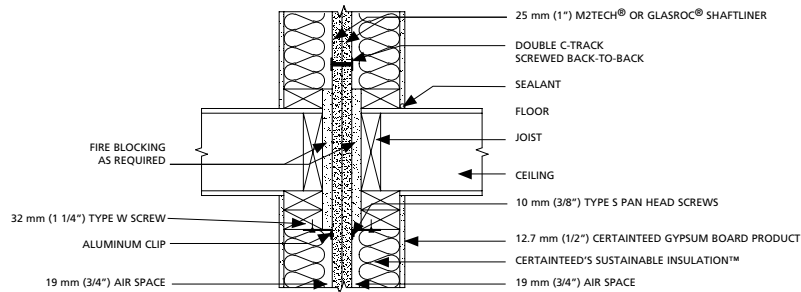

### EXTERIOR WALL INTERSECTION

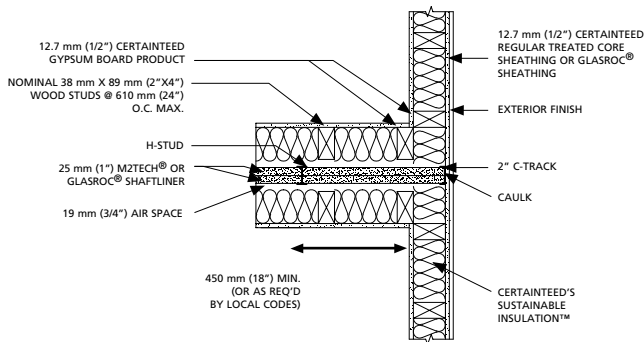

### PROTRUDING EXTERIOR WALL

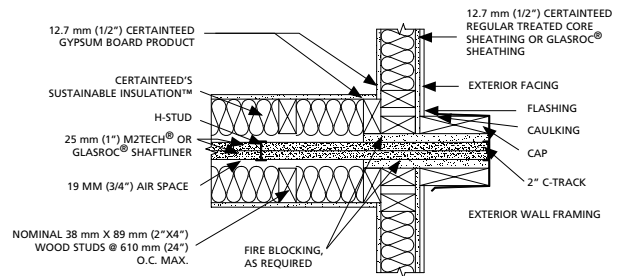

### TYPICAL ROOF JUNCTION DETAIL

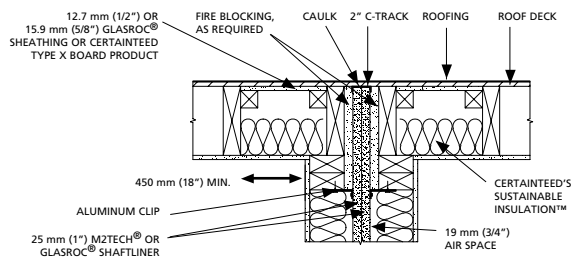

### TYPICAL ROOF PARAPET DETAIL

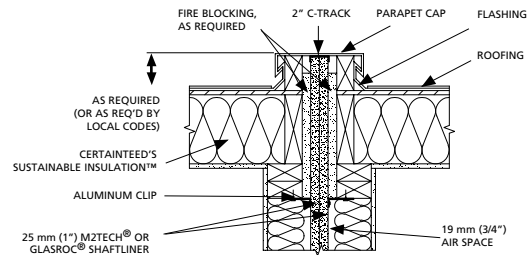

# STEEL JOIST FLOORS & CEILINGS

SOUND TRANSMISSION CLASS (STC)	CONSTRUCTION	DESCRIPTION	DESIGN NUMBER/TEST REPORTS
--------------------------------	--------------	-------------	----------------------------

## FIRE RESISTANCE RATING: 1h

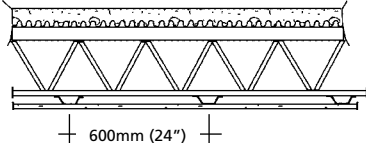
<b>53</b>	 <p style="text-align: center;">600mm (24")</p> <p style="text-align: center;">Thickness: 395mm (15 1/2") Weight: 156 kg/m<sup>2</sup> (32 lb/ft<sup>2</sup>)</p>	<p><b>System WFS1B</b> 51mm (2"), 19 MPa (2800 psi) concrete floor. 15.9mm (5/8") CertainTeed Type X products, 1 layer on steel furring channels.</p> <p>Fasten boards perpendicular to furring channels with 25mm (1") screws spaced 300mm (12") o.c. Locate screws 10mm (3/8") minimum from edges and ends of board. Joints must be offset. Tape and finish joints with CertainTeed products.</p>	<p>FIRE: ULC I509</p> <p>SOUND: Estimated</p>
-----------	--	---	---

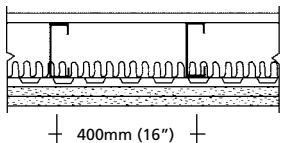
<b>54</b>	 <p style="text-align: center;">400mm (16")</p> <p style="text-align: center;">Thickness: 257mm (10 1/8") Weight: 68 kg/m<sup>2</sup> (14 lb/ft<sup>2</sup>)</p>	<p><b>System WFS154</b> 12.7mm (1/2") CertainTeed Type C products or 15.9mm (5/8") CertainTeed Type X products, 2 layers. Cold formed steel joists, resilient channels and 150mm (6") CertainTeed glass fibre. Subfloor-plywood, OSB or waferboard.</p> <p>Fasten base layer perpendicular to resilient channels with 32mm (1 1/4") screws spaced 300mm (12") o.c. Fasten face layer perpendicular to resilient channels with 41mm (1 1/2") screws spaced 300mm (12") o.c. Locate face layer end joints at double resilient channels. Locate screws minimum of 38mm (1 1/2") from edges of board. Joints must be offset. Tape and finish joints with CertainTeed products.</p>	<p>FIRE: NRC 98-764/ NBCC Table A-9.10.3.1B Floor F45d</p> <p>SOUND: NRC-IR-766</p>
-----------	---	--	---

Gypsum boards applied to underside of steel supports maximum spacing 600mm (24") o.c.



Thickness: Varies  
Weight: 22 kg/m<sup>2</sup> (4.6 lb/ft<sup>2</sup>) plus framing

<p><b>System WFS1XX</b> Fire rating provided by membrane only. 15.9mm (5/8") CertainTeed Type X products, 2 layers, steel structural member, maximum spacing 600mm (24") o.c.</p> <p>Fasten base layer perpendicular to supports with 25mm (1") screws spaced 300mm (12") o.c. Fasten face layer perpendicular to supports with 41mm (1 1/2") screws spaced 300mm (12") o.c. Joints must be offset. Tape and finish joints with CertainTeed products.</p>	<p>FIRE: NBCC (2010) Appendix D Table D.2.3.12</p>
---	--

## FIRE RESISTANCE RATING: 1-1/2h

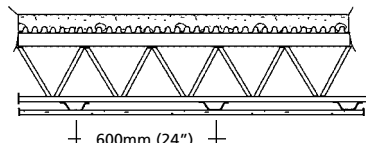
<b>53</b>	 <p style="text-align: center;">600mm (24")</p> <p style="text-align: center;">Thickness: 390mm (15 3/8") Weight: 166 kg/m<sup>2</sup> (34 lb/ft<sup>2</sup>)</p>	<p><b>System WFS1C</b> 51mm (2"), 21 MPa (3100 psi) concrete floor. 12.7mm (1/2") CertainTeed Type C products, 1 layer on steel furring channels.</p> <p>Fasten boards perpendicular to furring channels with 25mm (1") screws spaced 200mm (8") o.c. along end joints and 300mm (12") o.c. in the field. Locate screws 15mm (5/8") minimum from edges and ends of board. Joints must be offset. Tape and finish joints with CertainTeed products.</p>	<p>FIRE: ULC I510</p> <p>SOUND: Estimated</p>
-----------	--	--	---

## FIRE RESISTANCE RATING: 2h

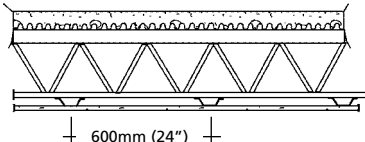
<b>54</b>	 <p style="text-align: center;">600mm (24")</p> <p style="text-align: center;">Thickness: 355mm (14") Weight: 190 kg/m<sup>2</sup> (39 lb/ft<sup>2</sup>)</p>	<p><b>System WFS2B</b> 64mm (2 1/2"), 28 MPa (4000 psi) concrete floor. 12.7mm (1/2") CertainTeed Type C products, 1 layer on steel furring channels.</p> <p>Fasten boards perpendicular to furring channels with 25mm (1") screws spaced 200mm (8") o.c. along end joints and 300mm (12") o.c. in the field. Locate screws 38mm (1 1/2") minimum from edges and ends of board. Joints must be offset. Tape and finish joints with CertainTeed products.</p>	<p>FIRE: ULC I511</p> <p>SOUND: Estimated</p>
-----------	--	--	---

# STEEL JOIST FLOORS & CEILINGS

SOUND  
TRANSMISSION  
CLASS (STC)

CONSTRUCTION

DESCRIPTION

DESIGN NUMBER/  
TEST REPORTS

## FIRE RESISTANCE RATING: **2h** (continued)

54

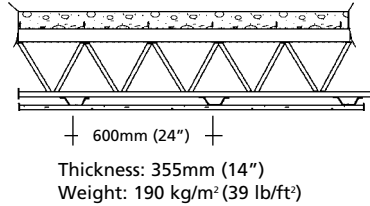

### System WFS2E

65mm (2½"), 24 MPa (3500 psi) concrete floor. 12.7mm (½") CertainTeed Type C products, 1 layer on steel furring channels.

Fasten boards perpendicular to furring channels with 25mm (1") screws spaced 300mm (12") o.c. Locate screws 19mm (¾") minimum from edges and 50mm (2") from ends of board. Butt joints may be protected by 75mm (3") wide by 12.7mm (½") thick gypsum board back blocking. Joints must be offset. Tape and finish joints with CertainTeed products.

FIRE: ULC I506

SOUND: Estimated

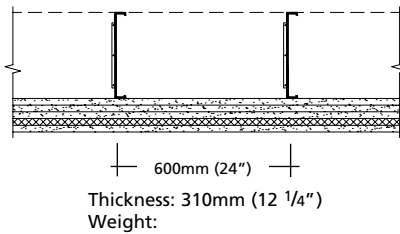

### System WFS2XX

Fire rating provided by membrane only. 15.9mm (5/8") CertainTeed Type X products, 4 layers. Steel Channel joists 203mm (8") deep with 38mm (1½") flanges and 12.7mm (½") stiffening flanges spaced 600mm (24") o.c. Minimum yield strength of joist is 227 MPa (33 ksi). Subflooring is 19mm (¾") thick T&G wood structural panels.

First three layers perpendicular to joist with adjacent butt joints staggered 1220mm (48"). Overlapping layers installed so edges and butt joints offset minimum 250mm (10") from previous layer. Fasten base layer with 32mm (1¼") screws spaced 300mm (12") o.c. Fasten second layer with 50mm (2") screws spaced 300mm (12") o.c. Fasten third layer with 63mm (2½") screws spaced 300mm (12") o.c. Fasten hat shaped furring channels spaced 600mm (24") o.c. perpendicular to joists with 63mm (2½") screws spaced 300mm (12") o.c. Fasten fourth layer perpendicular to hat channels with 29mm (1⅛") screws spaced 300mm (12") o.c. Screws spaced 12.7mm (½") from butt end joints and 25mm (1") from side joints. Tape and finish face layer joints with CertainTeed finishing products.

FIRE: ULC M514

## FIRE RESISTANCE RATING: **3h**

57

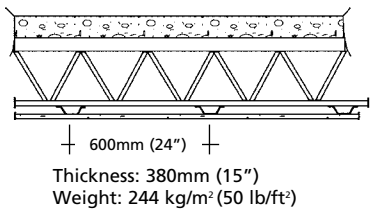

### System WFS3A

90mm (3½"), 24 MPa (3500 psi) concrete floor. 12.7mm (½") CertainTeed Type C products, 1 layer on steel furring channels.

Fasten boards perpendicular to furring channels with 25mm (1") screws spaced 300mm (12") o.c. Locate screws 19mm (¾") minimum from edges and 50mm (2") from ends of board. Butt joints may be protected by 75mm (3") wide by 12.7mm (½") thick gypsum board back blocking. Joints must be offset. Tape and finish joints with CertainTeed products.

FIRE: ULC I506

SOUND: Estimated

# WOOD JOIST FLOORS & CEILINGS

SOUND TRANSMISSION CLASS (STC)

CONSTRUCTION

DESCRIPTION

DESIGN NUMBER/TEST REPORTS

## FIRE RESISTANCE RATING: **3/4h**

50

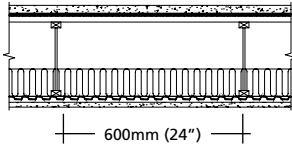

Thickness: 289mm (11 3/8")  
Weight: 60 kg/m<sup>2</sup> (12 lb/ft<sup>2</sup>)

### System WFF050

15.9mm (5/8") CertainTeed Type X products, 1 layer. 241mm (9 1/2") TJI® wood I-joists and resilient channels. Subfloor 19mm (3/4") OSB.

Fasten boards perpendicular to resilient channels with 32mm (1 1/4") screws. Locate edge joints between joists. End joints staggered at least 600mm (24"). Locate 2 rows of screws 19mm (3/4") from edge and 15mm (5/8") from end joints. Tape and finish joints with CertainTeed products.

FIRE:  
ITS WNR/FCA 45-01

SOUND: With insulation.

STC 57 with minimum 38mm (1 1/2") topping.

34

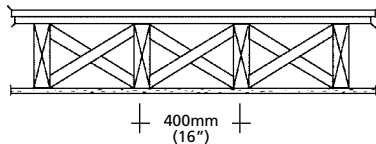

Thickness: 276mm (10 7/8")  
Weight: 59 kg/m<sup>2</sup> (12 lb/ft<sup>2</sup>)

### System WFF134

12.7mm (1/2") CertainTeed Type C products, 1 layer. 38mm x 235mm (2 x 10) wood joist. Subfloor 12mm (1/2") sheathing grade Douglas Fir plywood. Finished floor 15mm (5/8") T&G sheathing Douglas Fir plywood.

Fasten boards perpendicular to joists with 44mm (1 3/4") nails spaced 150mm (6") o.c. Locate nails 20mm (3/4") from edge and 15mm (5/8") from end joints. Tape and finish joints with CertainTeed products.

FIRE: ULC M502

SOUND: Estimated

35

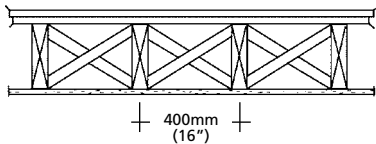

Thickness: 279mm (11")  
Weight: 64 kg/m<sup>2</sup> (13 lb/ft<sup>2</sup>)

### System WFF135

15.9mm (5/8") CertainTeed Type X products, 1 layer. 38mm x 235mm (2 x 10) wood joist. Subfloor 12mm (1/2") sheathing grade Douglas Fir plywood. Finished floor 15mm (5/8") T&G sheathing Douglas Fir plywood.

Fasten boards perpendicular to joists with 44mm (1 3/4") nails spaced 150mm (6") o.c. Locate nails 20mm (3/4") from edge and 15mm (5/8") from end joints. Tape and finish joints with CertainTeed products.

FIRE: ULC M500

SOUND: Estimated

41

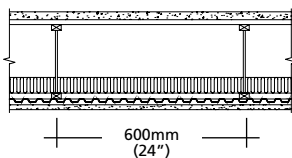

Thickness: 292mm (11 1/2")  
Weight: 60 kg/m<sup>2</sup> (12 lb/ft<sup>2</sup>)

### System WFF141B

15.9mm (5/8") CertainTeed Type C products, 1 layer. 241mm (9 1/2") TJI® wood I-joists with flanges minimum 2 1/2" wide by 1 1/2" deep and hat channels. Subfloor 15.9mm (5/8") OSB or plywood.

Fasten boards perpendicular to furring channels with 32mm (1 1/4") screws spaced 150mm (6") o.c. Locate edge joints between joists. End joints at double row of furring channel and staggered 1200mm (48"). Locate screws 76mm (3") from edges and ends of board. Tape and finish joints with CertainTeed products.

FIRE:  
WNR/WIJ 60-01

SOUND: Estimated

42

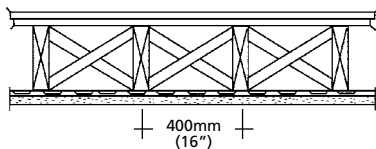

Thickness: 289mm (11 3/8")  
Weight: 59 kg/m<sup>2</sup> (12 lb/ft<sup>2</sup>)

### System WFF142

12.7mm (1/2") CertainTeed Type C products, 1 layer. 38mm x 235mm (2 x 10) wood joist and resilient channels. Subfloor 12mm (1/2") sheathing grade Douglas Fir plywood. Finished floor 15mm (5/8") T&G sheathing Douglas Fir plywood.

Fasten boards perpendicular to resilient channels with 25mm (1") screws spaced 300mm (12") o.c. Locate edge joints between joists. Fasten board end joints to additional pieces of resilient channel extending 150mm (6") beyond end joints and attached to joists. Locate screws 15mm (5/8") from edges and ends of board. Tape and finish joints with CertainTeed products.

FIRE: ULC M501

SOUND: Estimated

40

# WOOD JOIST FLOORS & CEILINGS

SOUND TRANSMISSION CLASS (STC)

CONSTRUCTION

DESCRIPTION

DESIGN NUMBER/TEST REPORTS

**FIRE RESISTANCE RATING: 1h (continued)**

54

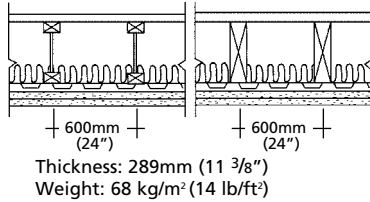

**System WFF154**

12.7mm (1/2") CertainTeed Type C products or 15.9mm (5/8") CertainTeed Type X products 2 layers. Wood joists or wood I-joists, resilient channels and insulation. Subfloor plywood, OSB or waferboard.

Fasten base layer perpendicular to furring channels with 32mm (1 1/4") screws spaced 300mm (12") o.c. Locate edge joints between joists. End joints staggered 1200mm (48"). Fasten face layer perpendicular to furring channels with 41mm (1 5/8") screws spaced 300mm (12") o.c. Joints must be staggered. Locate end joints of face layer at double resilient channels. Locate screws 38mm (1 1/2") from edges of board. Tape and finish joints with CertainTeed products.

FIRE: NRC 98-764

SOUND: NRC 95-115a

Gypsum boards applied to underside of wood supports maximum spacing 600mm (24") o.c.

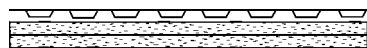

Thickness: varies  
Weight: 22 kg/m<sup>2</sup> (4.6 lb/ft<sup>2</sup>) plus framing

**System WFF1XX**

Fire rating provided by membrane only. 15.9mm (5/8") CertainTeed Type X products, 2 layers. Wood joists any type, resilient or furring channels (optional). Subfloor plywood, OSB or waferboard.

Fasten base layer perpendicular to resilient channels with 25mm (1") screws spaced 300mm (12") o.c. Fasten face layer perpendicular to resilient channels with 41mm (1 5/8") screws spaced 300mm (12") o.c. If resilient channels are not used, attach board perpendicular to wood joists with 51mm (2") screws spaced 300mm (12") o.c. for both layers. Joints must be offset. Tape and finish joints with CertainTeed products.

FIRE: NBCC (2010) Appendix D Table D.2.3.12

# WOOD JOIST FLOORS & CEILINGS

SOUND TRANSMISSION CLASS (STC)

CONSTRUCTION

DESCRIPTION

DESIGN NUMBER/ TEST REPORTS

**FIRE RESISTANCE RATING: 2h**

35

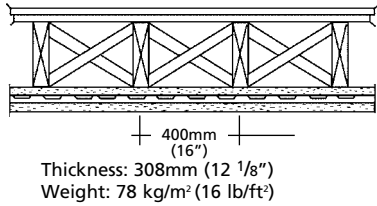

**System WFF235**

15.9mm (5/8") CertainTeed Type C products, 2 layers. 38mm x 235mm (2 x 10) wood joist and resilient channels. Subfloor 12mm (1/2") sheathing grade Douglas Fir plywood. Finished floor 15.9mm (5/8") T&G sheathing Douglas Fir plywood.

Fasten base layer perpendicular to joists with 63mm (2 1/2") 8d box nails spaced 180mm (7") o.c. Locate nails a minimum 15mm (5/8") from edges of boards. Attach resilient channels perpendicular to joists 600mm (24") o.c. with 64mm (2 1/2") 8d common nails. Provide a 102mm (4") overlap at splices and a minimum 19mm (3/4") wall clearance. Fasten face layer perpendicular to resilient channels with 25mm (1") screws spaced 300mm (12") o.c. Located edge joints between joists and fasten end joints of boards to additional pieces of resilient channel extending 150mm (6") beyond end joints and attached to joists. Locate screws a minimum 25mm (1") from edges of board. Tape and finish joints with CertainTeed products.

FIRE: ULC M503  
SOUND: Estimated

54

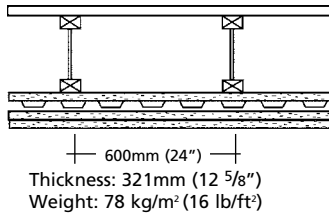

**System WFF254**

15.9mm (5/8") CertainTeed Type C products, 3 layers. 241mm (9 1/2") TJI® wood I-joists and resilient channels. Subfloor 15.9mm (5/8") OSB or plywood.

Fasten base layer perpendicular to joists with 41mm (1 5/8") screws spaced 200mm (8") o.c. Attach furring channels perpendicular to joists 400mm (16") o.c. with 48mm (1 7/8") screws at each I-joist. Fasten second layer perpendicular to furring channel with 32mm (1 1/4") screws spaced 200mm (8") o.c. and edges of board located between floor I-joists. Fasten face layer perpendicular to furring channels with 48mm (1 7/8") screws spaced 200mm (8") o.c. with joints offset. Locate screws 38mm (1 1/2") from edges and 19mm (3/4") from ends of boards. End joints must be staggered. Tape and finish joints with CertainTeed products.

FIRE: ITS WNR/FCA 120-03  
SOUND: Estimated, with 38 mm light weight gypsum concrete

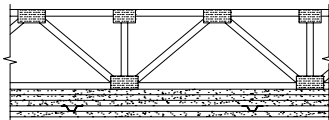

Thickness: 310mm (12 1/4")

**System WFF2XX**

Fire rating provided by membrane only. 15.9mm (5/8") CertainTeed Type X products, 4 layers. Wood joists, 38mm x 184mm (2" x 9") or minimum 450mm (17 3/4") deep parallel chord trusses spaced a maximum of 610mm (24"). Subflooring 19mm (3/4") thick T&G wood structural panels.

First three layers perpendicular to bottom of chord with adjacent butt joints staggered 1220mm (48"). Overlapping layers installed so edges and butt joints offset minimum 250mm (10") from previous layer. Fasten base layer with 32mm (1 1/4") screws spaced 300mm (12") o.c. Fasten second layer with 50mm (2") screws spaced 300mm (12") o.c. Fasten third layer with 63mm (2 1/2") screws spaced 300mm (12") o.c. Fasten hat shaped furring channels spaced 600mm (24") o.c. perpendicular to joists with 63mm (2 1/2") screws spaced 300mm (12") o.c. Fasten fourth layer perpendicular to hat channels with 29mm (1 1/8") screws spaced 300mm (12") o.c. Screws spaced 12.7mm (1/2") from butt end joints and 25mm (1") from side joints. Tape and finish face layer joints with CertainTeed finishing products.

FIRE: ULC M514

# COLUMN & BEAM PROTECTION

SOUND TRANSMISSION CLASS (STC)

CONSTRUCTION

DESCRIPTION

DESIGN NUMBER/TEST REPORTS

## FIRE RESISTANCE RATING: 1h

### Column

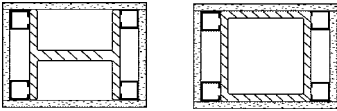

Minimum W200 x 46 (W8 x 31) or HSS -M/D 55 steel column.  
Weight: 15 kg/m<sup>2</sup> (3 lb/ft<sup>2</sup>)

### System WC1A

15.9mm (5/8") CertainTeed Type X products, 1 layer. 41mm (1 5/8") steel studs positioned at column corners, 12.7mm (1/2") less than column height. Install board vertically with 25mm (1") screws spaced 300mm (12") o.c. Apply corner bead with 25mm (1") screws spaced 300mm (12") o.c. Tape and finish joints with CertainTeed products.

FIRE: NBCC (2010)

Appendix D  
Table D-2.6.1.F.  
(see also UL X528, cUL X528)

## FIRE RESISTANCE RATING: 2h

### Beam

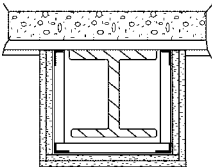

Minimum W200 x 36 (W8 x 24) steel beam.  
Weight: 29 kg/m<sup>2</sup> (6 lb/ft<sup>2</sup>)

### System WB2A

15.9mm (5/8") CertainTeed Type X products, 2 layers. 43mm x 25mm (1 11/16" x 1") steel channels and 25mm x 50mm (1" x 2") steel angles.

Leave a minimum 13mm (1/2") clearance at sides and bottom of beam. Attach angle to steel deck with 12mm (1/2") Phillips pan head screws spaced 300mm (12") o.c. Attach channel brackets to angle 600mm (24") o.c. with 12mm (1/2") Phillips pan head screws. Attach steel angle to lower corners of U-brackets with 12mm (1/2") Phillips pan head screws at 400mm (16") o.c. Install base layer of board with 30mm (1 1/4") screws spaced 400mm (16") o.c. Install face layer with 45mm (1 3/4") screws spaced 200mm (8") o.c. Joints must be offset. Attach corner bead, tape and finish joints with CertainTeed products.

FIRE: ULC 0501

### Beam

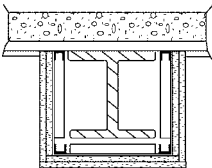

Minimum W200 x 36 (W8 x 24) steel beam.  
Weight: 29 kg/m<sup>2</sup> (6 lb/ft<sup>2</sup>)

### System WB2B

15.9mm (5/8") CertainTeed Type X products, 2 layers. 43mm x 25mm (1 11/16" x 1") steel channels.

Leave a minimum 13mm (1/2") clearance at sides and bottom of beam. Attach angle to steel deck with 12mm (1/2") Phillips pan head screws spaced 300mm (12") o.c. Attach channel brackets to angle 600mm (24") o.c. with 12mm (1/2") Phillips pan head screws. Insert channel angle in bracket, screw attachment is not required. Install base layer of board with 30mm (1 1/4") screws spaced 400mm (16") o.c. Install face layer with 45mm (1 3/4") screws spaced 200mm (8") o.c. Joints must be offset. Attach corner bead, tape and finish joints with CertainTeed products.

FIRE: ULC 0502

### Column

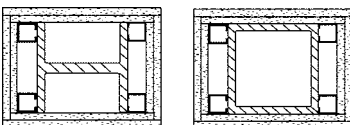

Minimum W250 x 73 (W10 x 49) steel column.  
Weight: 29 kg/m<sup>2</sup> (6 lb/ft<sup>2</sup>)

### System WC2A

15.9mm (5/8") CertainTeed Type X products, 2 layers. 41mm (1 5/8") steel studs positioned at column corners, 12.7mm (1/2") less than column height. Install base layer of board vertically with 25mm (1") screws spaced 600mm (24") o.c. Install face layer vertically with 44mm (1 3/4") screws spaced 300mm (12") o.c. Apply corner bead with 41mm (1 5/8") screws spaced 300mm (12") o.c. Tape and finish joints with CertainTeed products.

FIRE: NBCC (2010)

Appendix D  
Table D-2.6.1.F.  
(see also UL X528, cUL X528)

## FIRE RESISTANCE RATING: 3h

### Column

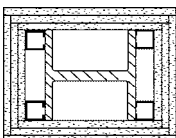

Minimum W250 x 73 (W10 x 49) steel column.  
Weight: 39 kg/m<sup>2</sup> (8 lb/ft<sup>2</sup>)

### System WC3A

15.9mm (5/8") CertainTeed Type X products, 3 layers. 41mm (1 5/8") steel studs positioned at column corners, 12.7mm (1/2") less than column height. Install base layer of board vertically with 25mm (1") screws spaced 600mm (24") o.c. Install second layer vertically with 44mm (1 3/4") screws spaced 300mm (12") o.c. Install face layer vertically with 57mm (2 1/4") No. 8 screws spaced 300mm (12") o.c. Apply corner bead with 51mm (2") 6d nails spaced 300mm (12") o.c. Tape and finish joints with CertainTeed products.

FIRE: ULC Z502

# CONCRETE BLOCK/GYPSUM BOARD WALLS

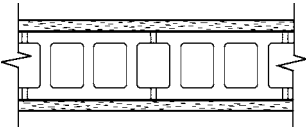
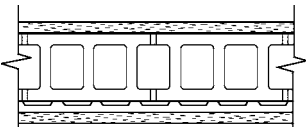
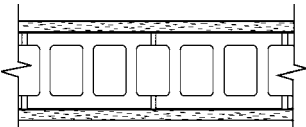
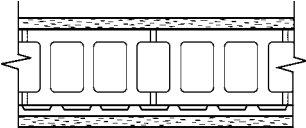
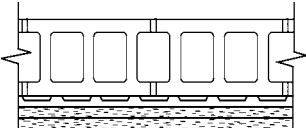
SOUND TRANSMISSION CLASS (STC)	CONSTRUCTION	DESCRIPTION	DESIGN NUMBER/ TEST REPORTS
<b>FIRE RESISTANCE RATING: 2h</b>			
47		<p><b>System WBA247</b>            140mm (nominal 6") concrete block, 15.9mm (5/8") CertainTeed Type X products, 1 layer, directly applied each side.</p> <p>Install board vertically or horizontal to each side with adhesive or mechanical fasteners. Tape and finish joints with CertainTeed products.</p>	<p>FIRE: NBCC (2010)            Table A-9.10.3.1.A            Wall B2b</p> <p>SOUND: NBCC (2010)            Table A-9.10.3.1.A            Wall B2b</p>
51		<p><b>System WBA251</b>            140mm (nominal 6") concrete block, 15.9mm (5/8") CertainTeed Type X products, 1 layer, directly applied one side. Other side, 1 layer on resilient channels.</p> <p>Install board on one side vertically or horizontally with adhesive or mechanical fasteners. Attach resilient channels horizontally at 600mm (24") o.c. or 400mm (16") o.c. to other side of the block wall. Install mineral fibre insulation in the furred space and fasten board vertically or horizontally to the resilient channels with 25mm (1") screws spaced 300mm (12") o.c. Tape and finish joints with CertainTeed products.</p>	<p>FIRE: NBCC (2010)            Table A-9.10.3.1.A            Wall B3a</p> <p>SOUND: NBCC (2010)            Table A-9.10.3.1.A            Wall B3a</p>
<b>FIRE RESISTANCE RATING: 3h</b>			
50		<p><b>System WBB350</b>            190mm (nominal 8") concrete block, 15.9mm (5/8") CertainTeed Type X products, 1 layer, directly applied each side.</p> <p>Install board vertically or horizontal to each side with adhesive or mechanical fasteners. Tape and finish joints with CertainTeed products.</p>	<p>FIRE: NBCC (2010)            Table A-9.10.3.1.A            Wall B2e</p> <p>SOUND: NBCC (2010)            Table A-9.10.3.1.A            Wall B2e</p>
54		<p><b>System WBB354</b>            190mm (nominal 8") concrete block, 15.9mm (5/8") CertainTeed Type X products, 1 layer, directly applied one side. Other side, 1 layer on resilient channel.</p> <p>Install board on one side vertically or horizontally with adhesive or mechanical fasteners. Attach resilient channels horizontally at 600mm (24") o.c. or 400mm (16") o.c. to other side of the block wall. Install mineral fibre insulation in the furred space and fasten board vertically or horizontally to the resilient channels with 25mm (1") screws spaced 300mm (12") o.c. Tape and finish joints with CertainTeed products.</p>	<p>FIRE: NBCC (2010)            Table A-9.10.3.1.A            Wall B3c</p> <p>SOUND: NBCC (2010)            Table A-9.10.3.1.A            Wall B3c</p>
56		<p><b>System WBB356</b>            190mm (nominal 8") concrete block, 15.9mm (5/8") CertainTeed Type X products, 2 layers, on resilient channel, 1 side.</p> <p>Attach resilient channels horizontally at 600mm (24") o.c. or 400mm (16") o.c. to one side of the block wall. Install mineral fibre insulation in the furred space and fasten base layer of board vertically or horizontally to the resilient channels with 25mm (1") screws spaced 300mm (12") o.c. Install face layer of board vertically or horizontally to resilient channel with 41mm (1 1/2") screws spaced 300mm (12") o.c. Joints must be offset. Tape and finish joints with CertainTeed products.</p>	<p>FIRE: NBCC (2010)            Table A-9.10.3.1.A            Wall B10a</p> <p>SOUND: NBCC (2010)            Table A-9.10.3.1.A            Wall B10a</p>



# STEEL STUD PERMABASE® PARTITIONS

## Non-Load Bearing

SOUND TRANSMISSION CLASS (STC)	CONSTRUCTION	DESCRIPTION	DESIGN NUMBER/TEST REPORTS
--------------------------------	--------------	-------------	----------------------------

### FIRE RESISTANCE RATING: 1h

<b>51</b>		<p><b>System PPC151</b></p> <p>Fasten 12.7mm (1/2") PermaBase horizontally to one side of the 92mm (3 5/8") steel studs using 25mm (1") screws spaced 150mm (6") o.c. on the perimeter and 200mm (8") o.c. in the field. Install 89mm (3 1/2") minimum 45 kg/m<sup>3</sup> (2.8 lb/ft<sup>3</sup>) mineral wool insulation in the cavity. Fasten 15.9mm (5/8") CertainTeed Type X products vertically to the other side with 25mm (1") screws spaced 300mm (12") o.c. All joints must be staggered a minimum of 300mm (12"). Tape and finish PermaBase joints with fiberglass mesh joint tape and latex-modified Portland cement mortar applied at a minimum rate of 2.7 kg/m<sup>2</sup> (0.55 lb/ft<sup>2</sup>). Tape and finish CertainTeed Type X joints with CertainTeed products.</p>	<p>FIRE: ULC W438</p> <p>SOUND: NRC CR-6466.1</p>
-----------	--	--	---

Thickness: 121 mm (4 3/4")  
Weight: 31 kg/m<sup>2</sup> (6.4 lb/ft<sup>2</sup>)

<b>55</b>		<p><b>System PPC155</b></p> <p>Fasten 12.7mm (1/2") CertainTeed Type C products vertically or horizontally to one side of 92mm (3 5/8") steel studs using 25mm (1") screws spaced 200mm (8") on the perimeter and 300mm (12") o.c. in the field. Fasten a face layer of 12.7mm (1/2") PermaBase horizontally to the same side using 41mm (1 5/8") screws spaced 150mm (6") o.c. on the perimeter and 200mm (8") o.c. in the field. Install 89mm (3 1/2") minimum 45 kg/m<sup>3</sup> (2.8 lb/ft<sup>3</sup>) mineral wool insulation in the cavity. Fasten 12.7mm (1/2") CertainTeed Type C products vertically to the other side with 25mm (1") screws spaced 200mm (8") on the perimeter and 300mm (12") o.c. in the field. All joints must be staggered a minimum of 300mm (12"). Tape and finish PermaBase joints with fiberglass mesh joint tape and latex-modified Portland cement mortar applied at a minimum rate of 2.7 kg/m<sup>2</sup> (0.55 lb/ft<sup>2</sup>). Tape and finish outer layer CertainTeed Type C joints with CertainTeed products. 15.9mm (5/8") CertainTeed Type X products may be substituted for the 12.7mm (1/2") CertainTeed Type C products in this assembly.</p>	<p>FIRE: ULC W437</p> <p>SOUND: NRC CR-6466.6</p>
-----------	--	---	---

Thickness: 130 mm (5 1/8")  
Weight: 38 kg/m<sup>2</sup> (7.8 lb/ft<sup>2</sup>)

<b>59</b>		<p><b>System PPC159</b></p> <p>Fasten 12.7mm (1/2") CertainTeed Type C products vertically or horizontally to one side of 92mm (3 5/8") steel studs using 25mm (1") screws spaced 300mm (12") o.c. Fasten a face layer of 12.7mm (1/2") PermaBase horizontally to the same side using 41mm (1 5/8") screws spaced 150mm (6") on the perimeter and 200mm (8") o.c. in the field. Install 89mm (3 1/2") minimum 45 kg/m<sup>3</sup> (2.8 lb/ft<sup>3</sup>) mineral wool insulation in the cavity. Fasten 12.7mm (1/2") PermaBase horizontally to the other side with 25mm (1") screws spaced 150mm (6") on the perimeter and 200mm (8") o.c. in the field. All joints must be staggered a minimum of 300mm (12"). Tape and finish PermaBase joints with fiberglass mesh joint tape and latex-modified Portland cement mortar applied at a minimum rate of 2.7 kg/m<sup>2</sup> (0.55 lb/ft<sup>2</sup>). 15.9mm (5/8") CertainTeed Type X products may be substituted for the 12.7mm (1/2") CertainTeed Type C products in this assembly.</p>	<p>FIRE: ULC W436</p> <p>SOUND: NRC CR-6466.3</p>
-----------	--	--	---

Thickness: 130 mm (5 1/8")  
Weight: 44 kg/m<sup>2</sup> (9.0 lb/ft<sup>2</sup>)

### FIRE RESISTANCE RATING: 2h

<b>59</b>		<p><b>System PPC259</b></p> <p>Fasten 12.7mm (1/2") CertainTeed Type C products vertically or horizontally to one side of 92mm (3 5/8") steel studs using 25mm (1") screws spaced 300mm (12") o.c. Fasten a face layer of 12.7mm (1/2") PermaBase horizontally to the same side using 41mm (1 5/8") screws spaced 230mm (9") o.c. Joints must be staggered a minimum of 300mm (12") from joints in the base layer. Install 89mm (3 1/2") minimum 34 kg/m<sup>3</sup> (2.1 lb/ft<sup>3</sup>) mineral wool insulation in the cavity. Fasten 12.7mm (1/2") ProRoc Type C board vertically or horizontally to other side using 25mm (1") screws spaced 300mm (12") o.c. Fasten a face layer of 12.7mm (1/2") CertainTeed Type C products vertically or horizontally to the same side using 41mm (1 5/8") screws spaced 230mm (9") o.c. Joints must be staggered a minimum of 600mm (24") from joints in the base layer. Tape and finish PermaBase joints with fiberglass mesh joint tape and latex-modified Portland cement mortar applied at a minimum rate of 2.7 kg/m<sup>2</sup> (0.55 lb/ft<sup>2</sup>). Tape and finish outer layer CertainTeed or M2Tech® Type C joints with CertainTeed products. 15.9mm (5/8") CertainTeed Type X products may be substituted for the 12.7mm (1/2") CertainTeed Type C products in this assembly.</p>	<p>FIRE: ULC W439</p> <p>SOUND: NRC CR-6466.4</p>
-----------	--	--	---

Thickness: 143 mm (5 5/8")  
Weight: 47 kg/m<sup>2</sup> (9.6 lb/ft<sup>2</sup>)

# STEEL STUD PERMABASE PARTITIONS

## Non-Load Bearing

SOUND TRANSMISSION CLASS (STC)

CONSTRUCTION

DESCRIPTION

DESIGN NUMBER/TEST REPORTS

**FIRE RESISTANCE RATING: 2h** (continued)

61

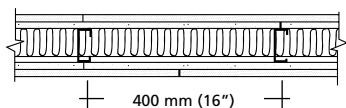

Thickness: 143 mm (5 5/8")  
Weight: 53 kg/m<sup>2</sup> (11 lb/ft<sup>2</sup>)

### System PPC261

Fasten 12.7mm (1/2") CertainTeed Type C products vertically or horizontally to each side of 92mm (3 5/8") steel studs using 25mm (1") screws spaced 300mm (12") o.c. Fasten a face layer of 12.7mm (1/2") PermaBase horizontally to each side using 41mm (1 5/8") screws spaced 230mm (9") o.c. Install 89mm (3 1/2") minimum 34 kg/m<sup>3</sup> (2.1 lb/ft<sup>3</sup>) mineral wool insulation in the cavity. All joints must be staggered a minimum of 300mm (12"). Tape and finish PermaBase joints with fiberglass mesh joint tape and latex-modified Portland cement mortar applied at a minimum rate of 2.7 kg/m<sup>2</sup> (0.55 lb/ft<sup>2</sup>). 15.9mm (5/8") CertainTeed Type X products may be substituted for the 12.7mm (1/2") CertainTeed Type C products' in this assembly.

FIRE: ULC W439

SOUND: NRC  
CR-6466.5

# STEEL STUD PERMABASE PARTITIONS

## (CHASE WALL)\* Non-load bearing

**FIRE RESISTANCE RATING: 1h**

53

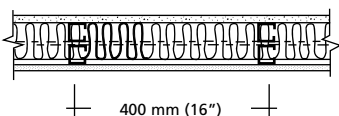

Thickness: 121 mm (4 3/4")  
Weight: 33 kg/m<sup>2</sup> (6.7 lb/ft<sup>2</sup>)

### System PPA153

Position paired 41mm (1 5/8") steel studs and track a minimum of 9.5mm (3/8") apart. Maintain separation between paired steel studs by attaching steel stud bridging 760mm (30") o.c. to steel stud webs using self-drilling, self-tapping screws (two per stud).

Fasten 12.7mm (1/2") PermaBase horizontally to one side using 25mm (1") screws spaced 150mm (6") o.c. on the perimeter and 200mm (8") o.c. in the field. Install 89mm (3 1/2") minimum 45 kg/m<sup>3</sup> (2.8 lb/ft<sup>3</sup>) mineral wool insulation in the cavity. Fasten 15.9mm (5/8") CertainTeed Type X products vertically to the other side with 25mm (1") screws spaced 300mm (12") o.c. All joints must be staggered a minimum of 300mm (12"). Tape and finish PermaBase joints with fiberglass mesh joint tape and latex-modified Portland cement mortar applied at a minimum rate of 2.7 kg/m<sup>2</sup> (0.55 lb/ft<sup>2</sup>). Tape and finish CertainTeed Type X products with CertainTeed products.

FIRE: ULC W438

SOUND: Estimate based on NRC  
CR-6466.1

57

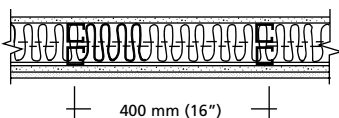

Thickness: 130 mm (5 1/8")  
Weight: 40 kg/m<sup>2</sup> (8.1 lb/ft<sup>2</sup>)

### System PPA157

Position paired 41mm (1 5/8") steel studs and track a minimum of 9.5mm (3/8") apart. Maintain separation between paired steel studs by attaching steel stud bridging 760mm (30") o.c. to steel stud webs using self-drilling, self-tapping screws (two per stud).

Fasten 12.7mm (1/2") CertainTeed Type C products vertically or horizontally to one side using 25mm (1") screws spaced 200mm (8") on the perimeter and 300mm (12") o.c. in the field. Fasten a face layer of 12.7mm (1/2") PermaBase horizontally to the same side using 41mm (1 5/8") screws spaced 150mm (6") o.c. on the perimeter and 200mm (8") o.c. in the field. Install 89mm (3 1/2") minimum 45 kg/m<sup>3</sup> (2.8 lb/ft<sup>3</sup>) mineral wool insulation in the cavity. Fasten 12.7mm (1/2") ProRoc Type C board vertically to the other side with 25mm (1") screws spaced 200mm (8") on the perimeter and 300mm (12") o.c. in the field. All joints must be staggered a minimum of 300mm (12"). Tape and finish PermaBase joints with fiberglass mesh joint tape and latex-modified Portland cement mortar applied at a minimum rate of 2.7 kg/m<sup>2</sup> (0.55 lb/ft<sup>2</sup>). Tape and finish outer layer CertainTeed Type C products' joints with CertainTeed products. 15.9mm (5/8") CertainTeed Type X products may be substituted for the 12.7mm (1/2") CertainTeed Type C products in this assembly.

FIRE: ULC W437

SOUND: NRC  
CR-6466.8

# STEEL STUD PERMABASE PARTITIONS (CHASE WALL)\* Non-Load Bearing

SOUND  
TRANSMISSION  
CLASS (STC)

CONSTRUCTION

DESCRIPTION

DESIGN NUMBER/  
TEST REPORTS

## FIRE RESISTANCE RATING: 1h (continued)

60

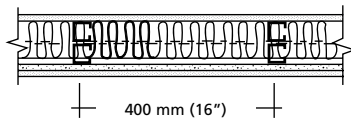

Thickness: 130 mm (5 1/8")  
Weight: 45 kg/m<sup>2</sup> (9.3 lb/ft<sup>2</sup>)

### System PPA160

Position paired 41mm (1 5/8") steel studs and track a minimum of 9.5mm (3/8") apart. Maintain separation between paired steel studs by attaching steel stud bridging 760mm (30") o.c. to steel stud webs using self-drilling, self-tapping screws (two per stud).

Fasten 12.7mm (1/2") CertainTeed Type C products vertically or horizontally to one side using 25mm (1") screws spaced 300mm (12") o.c. Fasten a face layer of 12.7mm (1/2") PermaBase horizontally to the same side using 41mm (1 5/8") screws spaced 150mm (6") on the perimeter and 200mm (8") o.c. in the field. Install 89mm (3 1/2") minimum 45 kg/m<sup>3</sup> (2.8 lb/ft<sup>3</sup>) mineral wool insulation in the cavity. Fasten 12.7mm (1/2") PermaBase horizontally to the other side with 25mm (1") screws spaced 150mm (6") on the perimeter and 200mm (8") o.c. in the field. All joints must be staggered a minimum of 300mm (12"). Tape and finish PermaBase joints with fiberglass mesh joint tape and latex-modified Portland cement mortar applied at a minimum rate of 2.7 kg/m<sup>2</sup> (0.55 lb/ft<sup>2</sup>). 15.9mm (5/8") CertainTeed Type X products may be substituted for the 12.7mm (1/2") CertainTeed Type C products in this assembly.

FIRE: ULC W436

SOUND: NRC  
CR-6466.7

## FIRE RESISTANCE RATING: 2h

61

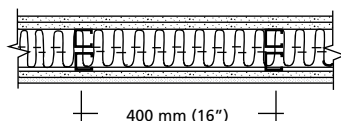

Thickness: 143 mm (5 5/8")  
Weight: 48 kg/m<sup>2</sup> (9.9 lb/ft<sup>2</sup>)

### System PPA261

Position paired 41mm (1 5/8") steel studs and track a minimum of 9.5mm (3/8") apart. Maintain separation between paired steel studs by attaching steel stud bridging 760mm (30") o.c. to steel stud webs using self-drilling, self-tapping screws (two per stud).

Fasten 12.7mm (1/2") CertainTeed Type C products vertically or horizontally to one side using 25mm (1") screws spaced 300mm (12") o.c. Fasten a face layer of 12.7mm (1/2") PermaBase horizontally to the same side using 41mm (1 5/8") screws spaced 230mm (9") o.c. Joints must be staggered a minimum of 300mm (12") from joints in the base layer. Install 89mm (3 1/2") minimum 34 kg/m<sup>3</sup> (2.1 lb/ft<sup>3</sup>) mineral wool insulation in the cavity. Fasten 12.7mm (1/2") CertainTeed Type C products vertically or horizontally to other side using 25mm (1") screws spaced 300mm (12") o.c. Fasten a face layer of 12.7mm (1/2") CertainTeed Type C products vertically or horizontally to the same side using 41mm (1 5/8") screws spaced 230mm (9") o.c. Joints must be staggered a minimum of 600mm (24") from joints in the base layer. Tape and finish PermaBase joints with fiberglass mesh joint tape and latex-modified Portland cement mortar applied at a minimum rate of 2.7 kg/m<sup>2</sup> (0.55 lb/ft<sup>2</sup>). Tape and finish outer layer CertainTeed Type C products' joints with CertainTeed products. 15.9mm (5/8") CertainTeed Type X products may be substituted for the 12.7mm (1/2") CertainTeed Type C products in this assembly.

FIRE: ULC W439

SOUND: NRC  
CR-6466.9

63

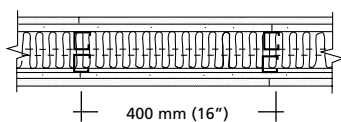

Thickness: 143 mm (5 5/8")  
Weight: 54 kg/m<sup>2</sup> (11 lb/ft<sup>2</sup>)

### System PPA263

Position paired 41mm (1 5/8") steel studs and track a minimum of 9.5mm (3/8") apart. Maintain separation between paired steel studs by attaching steel stud bridging 760mm (30") o.c. to steel stud webs using self-drilling, self-tapping screws (two per stud).

Fasten 12.7mm (1/2") CertainTeed Type C products vertically or horizontally to each side using 25mm (1") screws spaced 300mm (12") o.c. Fasten a face layer of 12.7mm (1/2") PermaBase horizontally to each side using 41mm (1 5/8") screws spaced 230mm (9") o.c. Install 89mm (3 1/2") minimum 34 kg/m<sup>3</sup> (2.1 lb/ft<sup>3</sup>) mineral wool insulation in the cavity. All joints must be staggered a minimum of 300mm (12"). Tape and finish PermaBase joints with fiberglass mesh joint tape and latex-modified Portland cement mortar applied at a minimum rate of 2.7 kg/m<sup>2</sup> (0.55 lb/ft<sup>2</sup>). 15.9mm (5/8") CertainTeed Type X products may be substituted for the 12.7mm (1/2") CertainTeed Type C products in this assembly.

FIRE: ULC W439

SOUND: NRC  
CR-6466.10

\* Chase Wall Partitions provide a space in the partition cavity to accommodate plumbing, electrical and other services.

[ **BeCertain** ] Confidence worth building on.™

**ASK ABOUT ALL OF OUR OTHER CERTAINTEED® PRODUCTS AND SYSTEMS:**

ROOFING • SIDING • TRIM • DECKING • RAILING • FENCE • FOUNDATIONS  
GYPSUM • CEILINGS • INSULATION • PIPE

[www.certainteed.com](http://www.certainteed.com)

CertainTeed Corporation  
P.O. Box 860  
Valley Forge, PA 19482

Professional: 800-233-8990  
Consumer: 800-782-8777

© 06-2013 CertainTeed Gypsum, Inc. Rev. 06-2012  
Printed on recycled paper. CTG-4080

