

CertainTeed

ProRoc[®] BRAND

UL Design V450 Fire-Rated Wall Assemblies

1-Hour Fire-Resistance Rating Non-Loadbearing Wall Assembly

One layer of CertainTeed ProRoc[®] Brand 5/8" (15.9mm) Type X Gypsum Board applied horizontally or vertically to either side of minimum 3-5/8" (92mm) Dietrich UltraSTEEL[®] Framing spaced on 24" (600mm) centers.

STC 39 without insulation
STC 47 with insulation
STC 52 with insulation and resilient channel

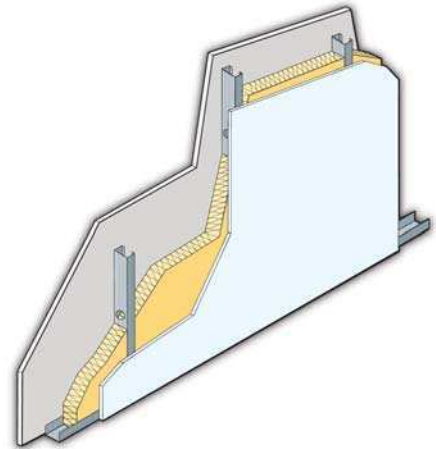

2-Hour Fire-Resistance Rating Non-Loadbearing Wall Assembly

Two layers of CertainTeed ProRoc[®] Brand 5/8" (15.9mm) Type X Gypsum Board applied horizontally or vertically to either side of minimum 2-1/2" (64mm) Dietrich UltraSTEEL[®] Framing spaced on 24" (600mm) centers.

STC 48 without insulation
STC 57 with insulation
STC 61 with insulation and resilient channel

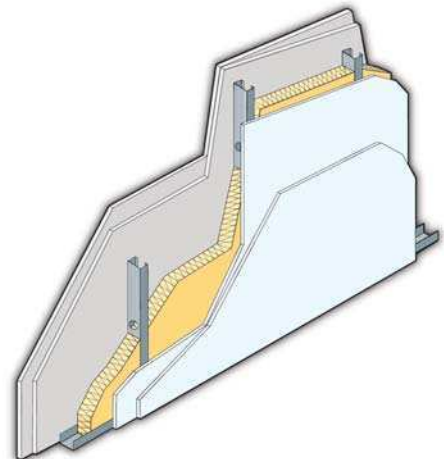

Vertical Board Application

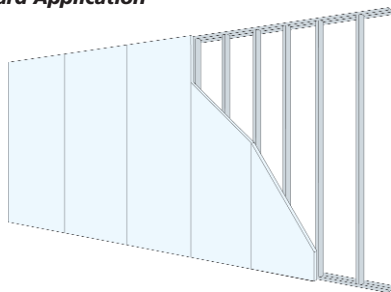

Horizontal Board Application

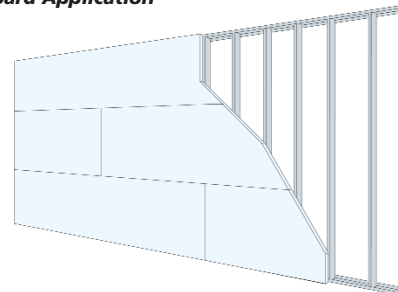

CertainTeed ProRoc[®] BRAND UL Design V450 Fire-Rated Wall Assemblies

1-Hour Fire-Resistance Rating Non-Loadbearing Wall Assembly

Cavity Depth: 3-5/8" (92mm)
Wall Thickness: 4-7/8" (124mm)
Weight: 5.2 psf (25.4 kg/m²)

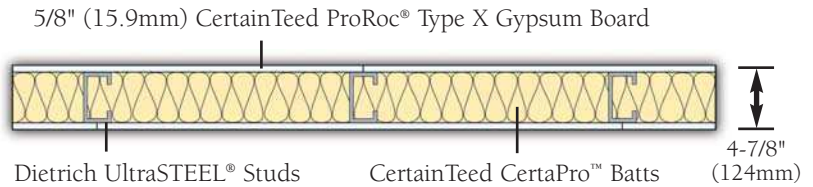

1-Hour Fire Resistance Rating

Gypsum Board

5/8" (15.9mm) ProRoc[®] Type X Gypsum Board, one layer applied horizontally with joints aligned on opposite sides of the wall or vertically with joints staggered.

Steel Framing

Minimum 3-5/8" (92mm) Dietrich UltraSTEEL[®] Framing spaced 24" (600mm) o.c.

Cavity Insulation (optional)

3-1/2" (89mm) CertainTeed CertaPro[™] Batts (or equivalent).

Fastening

Fastening #6 1" (25mm) Type S bugle head steel screws for horizontal application 8" (200mm) o.c. perimeter and field. For vertical application, 8" (200mm) o.c. perimeter and 12" (300mm) field.

Finishing System

Tape and finish joints with ProRoc[®] products (or equivalent).

Note: Horizontal joints and horizontal butt joints can be aligned and unbacked.

2-Hour Fire-Resistance Rating Non-Loadbearing Wall Assembly

Cavity Depth: 2-1/2" (64mm)
Wall Thickness: 5" (127mm)
Weight: 10.3 psf (50.4 kg/m²)

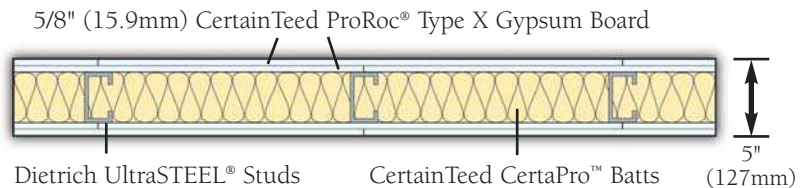

2-Hour Fire Resistance Rating

Gypsum Board

5/8" (15.9mm) ProRoc[®] Type X Gypsum Board, two layers applied horizontally with face layer offset a minimum of 12" (300mm) from base layer or vertically with joints staggered.

Steel Framing

Minimum 2-1/2" (64mm) Dietrich UltraSTEEL[®] Framing spaced 24" (600mm) o.c.

Cavity Insulation (optional)

2-1/2" (64mm) CertainTeed CertaPro[™] Batts (or equivalent).

Fastening

Base Layer: #6 1" (25mm) Type S bugle head steel screws spaced 16" (400mm) o.c. perimeter and field. Face Layer: #6 1-5/8" (41mm) Type S bugle head steel screws spaced 16" (400mm) o.c. perimeter and field.

Finishing System

Tape and finish joints with ProRoc[®] products (or equivalent).

Note: Horizontal joints and horizontal butt joints can be aligned and unbacked.

ASK ABOUT OUR OTHER CERTAINTEED PRODUCTS AND SYSTEMS:

EXTERIOR: ROOFING • SIDING • FENCE • DECKING • RAILING • MILLWORK • FOUNDATIONS • PIPE
INTERIOR: INSULATION • WALLS • CEILINGS

CertainTeed Corporation
P.O. Box 860
Valley Forge, PA 19482

Professional: 800-233-8990
Consumer: 800-782-8777
www.certainteed.com

CertainTeed

Characteristics, properties or performance of materials or systems manufactured by CertainTeed herein described are derived from data obtained under controlled test conditions. CertainTeed makes no warranties, express or implied, as to their characteristics, properties or performance under any variations from such conditions in actual construction. CertainTeed assumes no responsibility for the effects of structural movement.

UltraSTEEL[®] is a Trademark of Hadley Industries plc. Products manufactured using the UltraSTEEL[®] process are protected by granted USA Patents (Nos. 6,183,879 and 5,689,990) and granted Canadian Patent (No. 2,149,914/1993) together with design registration.

™ © CertainTeed and the tag line "Quality made certain. Satisfaction guaranteed." are trademarks of CertainTeed Corporation. All other trademarks are the property of its affiliates and related companies.

NOTICE: The information in this document is subject to change without notice. CertainTeed assumes no responsibility for any errors that may inadvertently appear in this document.

©11/07 CertainTeed Corporation. Printed in U.S.A. CTG-2202/5M/11-2007