

CertainTeed

# FLINTLASTIC<sup>®</sup>

Application Handbook – Third Edition

An educational program  
for professional roofing contractors

FLINTLASTIC<sup>®</sup> SA  
APPLICATION SPECIALIST



**CertainTeed**  
SAINT-GOBAIN

**CertainTeed Flintlastic® Modified Bitumen roofing products represent the finest in quality roofing materials. Beyond quality materials, proper application is the key to the successful performance of any roofing system.**

This pocket guide is intended as a handy reference tool only. It is not all-inclusive, and before installation of any Flintlastic Modified Bitumen Roof System the CertainTeed Commercial Roof Systems Manual must also be referenced.

Some other places of reference are:

**CertainTeed Roof Specification:**

<http://www.certainteed.com/additionalresources/roofing/Roof-Systems-Specs>

**Warranty site:**

<http://www.ctndl.com/Login.asp>

**Commercial Warranty and Technical Department:**

**18 Moores Road, Malvern, PA 19355**

800-396-8134 ext. 2

CertainTeed Flintlastic Modified Bitumen roofing products are intended for use by professional roofing contractors only. It is the sole responsibility of the applicator to exercise all appropriate safety precautions in the application and handling of roofing products utilizing torches, hot asphalt, cold adhesive and related equipment.

**For more information concerning safety contact the following agencies:**

**NRCA (National Roofing Contractors Association)**

10255 W. Higgins Rd., Ste. 600, Rosemont, IL 60018-5607

Ph. 847-299-9070

**MRCA (Midwest Roofing Contractors Association)**

4840 Bob Billings Parkway, Ste. 1000, Lawrence, KS 66049-3876

Ph. 800-497-6722

**NERCA (North East Roofing Contractors Association)**

150 Grossman Drive Street, Ste. 313, Braintree, MA 02184

Ph. 781-849-0555

**WSRCA (Western States Roofing Contractors Association)**

275 Tennant Avenue, Suite #106, Morgan Hill, CA 95037

Ph. 800-725-0333/650-938-5441

**ARMA (Asphalt Roofing Manufacturers Association)**

1156 15th St. NW, Ste. 900, Washington, DC 20005

Ph. 202-207-0917

**NFPA (National Fire Protection Association)**

1 Batterymarch Park, Quincy, MA 02169-7471

Ph. 617-770-3000

## Table of Contents

2	Flintlastic® Modified Bitumen Products Quick Reference Charts
6	BUR (Built-Up Roofing) Products Quick Reference Charts
7	Accessory Products Quick Reference Charts
10	Material Handling and Storage
	Weather Precautions
	Roof Slope and Drainage
11	Substrate Preparation
	Base Sheet Application
12	Vapor Retarders
	Insulation
13	Re-Cover Considerations
17	Roof Relief Vents
	Proper Tools
	Proper Attire
18	Roof Layout
19	Basic Application: Flintlastic APP Modified Bitumen
22	Flashing Details: Flintlastic APP Modified Bitumen
30	Basic Application: Flintlastic SBS Modified Bitumen
33	Flashing Details: Flintlastic SBS Modified Bitumen
38	Basic Application: Flintlastic SA Modified Bitumen
45	Typical Construction Details (Flintlastic SA 2-Ply System)
50	Typical Construction Details (Flintlastic SA 3-Ply System)
52	Job Completion
	Safety Tips
58	Reference Tables
62	Flintlastic Application Specialist Questions

## What's in a Name?

Each roll of CertainTeed Flintlastic Modified Bitumen has a 3-letter identification code in its name. Example:

### **Flintlastic GTA**

1st letter designates surface, **SMOOTH or GRANULAR**  
2nd letter designates application process, **TORCH or MOP**  
3rd letter designates modifier, **SBS or APP**

## Self-Adhering SBS Modified Bitumen

Product	Description	Specifications				
		Application Method*	Thickness (Typical)	Weight per Roll	Coverage per Roll	ASTM Reference
Flintlastic® SA NailBase	SBS modified, extra-strength fiberglass reinforced anchor sheet designed for self-adhering Flintlastic roof membranes	MF	1.5mm (60mils)	82 lbs.	200 sq. ft.	D4601, Type II
Flintlastic® SA PlyBase	SBS modified, extra-strength fiberglass reinforced self-adhering base ply designed for self-adhering Flintlastic roof membranes	SA	1.5mm (60mils)	86 lbs.	200 sq. ft.	D4601, Type II, D1970
Flintlastic® SA MidPly	SBS modified, heavy-duty fiberglass reinforced self-adhering base or inter ply designed for self-adhering Flintlastic roof membranes	SA	2.8mm (110mils)	63 lbs.	100 sq. ft.	D6163, Grade S, Type I, D1970
Flintlastic® SA Cap	SBS modified, stress-resistant polyester reinforced self-adhering cap membrane with granule surface	SA	4.0mm (160mils)	95 lbs.	100 sq. ft.	D6164, Grade G, Type I, D7505
Flintlastic® SA Cap CoolStar®†	SBS modified, stress-resistant polyester reinforced self-adhering cap membrane with reflective CoolStar granule surface	SA	4.0mm (160mils)	98 lbs.	100 sq. ft.	D6164, Grade G, Type I, D7505
Flintlastic® SA Cap FR	SBS modified, fire-resistant heavy-duty fiberglass reinforced self-adhering cap membrane with granule surface	SA	3.2mm (125mils)	88 lbs.	100 sq. ft.	D6163, Grade G, Type I, UL 2218 Class 4, D7530
Flintlastic® SA Cap FR CoolStar®†	SBS modified, fire-resistant, heavy-duty fiberglass reinforced self-adhering cap membrane with reflective CoolStar granule surface	SA	3.2mm (125mils)	90 lbs.	100 sq. ft.	D6163, Grade G, Type I, UL 2218 Class 4, D7530

\*Application Methods: MF = Mechanically Fastened / HA = Hot Asphalt / CA = Cold Asphalt / TA = Torch Applied / SA = Self-Adhering  
 †Special run. Minimum order quantities may apply.

## SBS Modified Bitumen – Base/Interply Sheets

Product	Description	Specifications				
		Application Method*	Thickness (Typical)	Weight per Roll	Coverage per Roll	ASTM Reference
Flexiglas® Base Sheet†	SBS modified, extra-strength fiberglass reinforced base sheet	HA, CA, MF	1.2mm (48mils)	90 lbs.	300 sq. ft.	D4601, Type II
All Weather/Empire® Base Sheet	SBS modified, dimensionally stable fiberglass reinforced base sheet, may be used as tile underlayment	MF, HA, CA	1.3mm (50mils)	70 lbs.	200 sq. ft.	D4601, Type II
Flintlastic® Base 20	SBS modified, fire-resistant, heavy-duty fiberglass reinforced base sheet	HA, CA, MF	2.3mm (92mils)	88 lbs.	150 sq. ft.	D4601, Type II, D6163, Grade S, Type I
Flintlastic® Base 20 Tr	SBS modified, fire-resistant, torchable, heavy-duty fiberglass reinforced base sheet	TA, MF	3.0mm (120mils)	80 lbs.	100 sq. ft.	D4601, Type II, D6163, Grade S, Type I
Flintlastic® Poly SMS Base Sheet	SBS modified, stress resistant polyester reinforced base sheet	HA, CA, MF	2.0mm (80mils)	89 lbs.	200 sq. ft.	D4601, Type II
Flintlastic® Ultra Poly SMS Base Sheet	Premium SBS modified, stress resistant polyester reinforced base sheet	TA, HA, CA, MF	3.7mm (148mils)	89 lbs.	100 sq. ft.	D6164, Grade S, Type I
Black Diamond® Base Sheet	SBS modified, dimensionally stable fiberglass reinforced self-adhering base ply with fine granule surface	SA	1.4mm (55mils)	78 lbs.	200 sq. ft.	D1970, D4601
Flintlastic® Ultra Glass SA	SBS modified, heavy-duty, fiberglass reinforced self-adhering base ply with fine sand surface	SA	3.0mm (120mils)	72 lbs.	100 sq. ft.	D6163, Grade S, Type I, D1970

\*Application Methods: MF = Mechanically Fastened / HA = Hot Asphalt / CA = Cold Asphalt / TA = Torch Applied / SA = Self-Adhering

†Special run. Minimum order quantities may apply.

## SBS Modified Bitumen – Cap Sheets

		Specifications				
Product	Description	Application Method*	Thickness (Typical)	Weight per Roll	Coverage per Roll	ASTM Reference
Flintlastic® FR Dual Cap	SBS modified, extra-tough and stress resistant fiberglass/polyester reinforced cap membrane with granule surface	HA, CA	4.3mm (169mils)	103 lbs.	100 sq. ft.	D6162, Grade G, Type I
Flintlastic® FR Cap 30	SBS modified, fire-resistant, heavy-duty fiberglass reinforced cap membrane with granule surface	HA, CA	3.3mm (130mils)	85 lbs.	100 sq. ft.	D6163, Grade G, Type I
Flintlastic® FR Cap 30 CoolStar® <sup>†</sup>	SBS modified, fire-resistant, heavy-duty fiberglass reinforced cap membrane with reflective CoolStar granule surface	HA, CA	3.3mm (130mils)	88 lbs.	100 sq. ft.	D6163, Grade G, Type I
Flintlastic® FR Cap 30 T <sup>†</sup>	SBS modified, fire-resistant, torchable, heavy-duty fiberglass reinforced cap membrane with granule surface	TA	3.8mm (150mils)	96 lbs.	100 sq. ft.	D6163, Grade G, Type I
Flintlastic® FR Cap 30 T CoolStar® <sup>†</sup>	SBS modified, fire-resistant, torchable, heavy-duty fiberglass reinforced cap membrane with reflective CoolStar granule surface	TA	3.8mm (150mils)	98 lbs.	100 sq. ft.	D6163, Grade G, Type I
Flintlastic® FR-P	SBS modified, fire-resistant, stress resistant polyester reinforced cap membrane with granule surface	HA, CA	4.2mm (168mils)	100 lbs.	100 sq. ft.	D6164, Grade G, Type I
Flintlastic® FR-P CoolStar® <sup>†</sup>	SBS modified, fire-resistant, stress resistant polyester reinforced cap membrane with reflective CoolStar granule surface	HA, CA	4.2mm (168mils)	102 lbs.	100 sq. ft.	D6164, Grade S, Type I
Flintlastic® Premium FR-P	SBS modified, fire-resistant, extra-tough and stress resistant polyester reinforced cap membrane with granule surface	HA, CA	4.2mm (168mils)	100 lbs.	100 sq. ft.	D6164, Grade G, Type II
Flintlastic® Premium FR-P CoolStar® <sup>†</sup>	SBS modified, fire-resistant, extra-tough and stress resistant polyester reinforced cap membrane with reflective CoolStar granule surface	HA, CA	4.2mm (168mils)	102 lbs.	100 sq. ft.	D6164, Grade G, Type II
Flintlastic® GMS	SBS modified, stress resistant polyester reinforced cap membrane with granule surface	HA, CA	3.7mm (145mils)	93 lbs.	100 sq. ft.	D6164, Grade G, Type I
Flintlastic® GMS CoolStar® <sup>†</sup>	SBS modified, stress resistant polyester reinforced cap membrane with reflective CoolStar granule surface	HA, CA	3.7mm (145mils)	96 lbs.	100 sq. ft.	D6164, Grade G, Type I
Flintlastic® GTS-FR	SBS modified, fire-resistant torchable, extra-tough and stress resistant polyester reinforced cap membrane with granule surface	TA	4.0mm (160mils)	103 lbs.	100 sq. ft.	D6164, Grade G, Type II
Flintlastic® GTS-FR CoolStar® <sup>†</sup>	SBS modified, fire-resistant torchable, extra-tough and stress resistant polyester reinforced cap membrane with reflective CoolStar granule surface	TA	4.0mm (160mils)	105 lbs.	100 sq. ft.	D6164, Grade G, Type II

\*Application Methods: MF = Mechanically Fastened / HA = Hot Asphalt / CA = Cold Asphalt / TA = Torch Applied / SA = Self-Adhering

<sup>†</sup>Special run. Minimum order quantities may apply.

## APP Modified Bitumen – Base/Interply Sheets

		Specifications				
Product	Description	Application Method*	Thickness (Typical)	Weight per Roll	Coverage per Roll	ASTM Reference
Flintlastic® APP Base T	APP modified, extra-strength fiberglass reinforced torchable base sheet with smooth surface	MF, TA	2.0mm (80mils)	97 lbs.	200 sq. ft.	D6509
Flintlastic® STA	APP modified, stress resistant polyester reinforced torchable base, inter ply or cap membrane (with coating) with smooth surface	TA	3.8mm (150mils)	86 lbs.	100 sq. ft.	D6222, Grade S, Type I

## APP Modified Bitumen – Cap Sheets

		Specifications				
Product	Description	Application Method*	Thickness (Typical)	Weight per Roll	Coverage per Roll	ASTM Reference
Flintlastic® STA	APP modified, stress resistant polyester reinforced torchable base, inter ply or cap membrane (with coating) with smooth surface	TA	3.8mm (150mils)	86 lbs.	100 sq. ft.	D6222, Grade S, Type I
Flintlastic® GTA	APP modified, stress resistant polyester reinforced torchable cap membrane with granule surface	TA	4.0mm (160mils)	103 lbs.	100 sq. ft.	D6222, Grade G, Type I
Flintlastic® GTA Coolstar®	APP modified, stress resistant polyester reinforced torchable cap membrane with reflective CoolStar granule surface	TA	4.0mm (160mils)	106 lbs.	100 sq. ft.	D6222, Grade G, Type I
Flintlastic® GTA-FR	APP modified, fire-resistant, stress resistant polyester reinforced torchable cap membrane with reflective CoolStar granule surface	TA	4.0mm (160mils)	103 lbs.	100 sq. ft.	D6222, Grade G, Type I
Flintlastic® GTA-FR Coolstar®	APP modified, fire-resistant, stress resistant polyester reinforced torchable cap membrane with reflective CoolStar granule surface	TA	4.0mm (160mils)	106 lbs.	100 sq. ft.	D6222, Grade G, Type I

\*Application Methods: MF = Mechanically Fastened / HA = Hot Asphalt / CA = Cold Asphalt / TA = Torch Applied / SA = Self-Adhering

## BUR (Built-Up Roofing) – Base Sheets

		Specifications				
Product	Description	Application Method*	Thickness (Typical)	Weight per Roll	Coverage per Roll	ASTM Reference
Glasbase™ Base Sheet	Non-modified, extra-strength fiberglass reinforced base sheet	MF, HA, CA	1.0mm (40mils)	75 lbs.	300 sq. ft.	D4601, Type II, UL, Type G2
Yosemite® Venting Base Sheet	Non-modified, heavy-duty fiberglass reinforced base sheet with embossed channels for venting moisture, ideal for recover applications	MF, HA	2.8mm (110mils)	84 lbs.	100 sq. ft.	D3909, D4897, Type II, UL Type G3

## BUR (Built-Up Roofing) – Interply Sheets

		Specifications				
Product	Description	Application Method*	Thickness (Typical)	Weight per Roll	Coverage per Roll	ASTM Reference
Flintglas® Ply Sheet Type 4	Non-modified, extra-strength fiberglass reinforced base or inter ply	HA	0.6mm (24mils)	36 lbs.	500 sq. ft.	D2178, Type IV, UL, Type G1
Flintglas® Premium Ply Sheet Type 6	Premium, non-modified, heavyweight fiberglass reinforced base or inter ply	HA	0.8mm (32mils)	36 lbs.	500 sq. ft.	D2178, Type VI, UL, Type G1

## BUR (Built-Up Roofing) – Cap Sheets

		Specifications				
Product	Description	Application Method*	Thickness (Typical)	Weight per Roll	Coverage per Roll	ASTM Reference
Flintglas® MS Cap Sheet	Non-modified, extra-strength fiberglass reinforced cap sheet with granule surface	HA, CA	3.0mm (120mils)	77 lbs.	100 sq. ft.	D3909, UL Type G3
Flintglas® MS Cap Sheet Coolstar®	Non-modified, extra-strength fiberglass reinforced cap sheet with reflective CoolStar granule surface	HA, CA	3.0mm (120mils)	80 lbs.	100 sq. ft.	D3909

## Underlayments

		Specifications				
Product	Description	Application Method*	Thickness (Typical)	Weight per Roll	Coverage per Roll	ASTM Reference
All Weather/Empire® Base Sheet	SBS modified, dimensionally stable fiberglass reinforced base sheet, may be used as tile underlayment	MF, HA, CA	1.3mm (50mils)	70 lbs.	200 sq. ft.	D4601, Type II
MetaLayment®	High-temperature resistant, SBS modified, self-adhering, dimensionally stable fiberglass reinforced underlayment for metal roofing	SA	1.5mm (60mils)	54 lbs.	200 sq. ft.	D1970

\*Application Methods: MF = Mechanically Fastened / HA = Hot Asphalt / CA = Cold Asphalt / TA = Torch Applied / SA = Self-Adhering



## Roofing Insulation and Coverboards

Product Name	Description	Specifications
FlintBoard® ISO	Features a closed-cell polyiso core laminated to heavy, black (non-asphaltic), fiber-reinforced felt facers	ASTM C1289, Type II
FlintBoard® ISO-T	Features a tapered design to promote positive drainage	ASTM C1289, Type II
FlintBoard® ISO Cold	Features a heavy-duty facer designed specifically for single ply, COLD applied hybrid BUR and SBS modified bitumen roof systems	ASTM C1289, Type II
FlintBoard® ISO-T Cold	Features a heavy-duty facer and a tapered design to promote positive drainage	ASTM C1289, Type II
FlintBoard® ISO Plus	Composite roof insulation with foam core laminated to 1/2" perlite with a fiber-reinforced felt facer	ASTM C1289, Type II or Type III
FlintBoard® ISO-T Plus	Composite roof insulation with a tapered design to promote positive drainage	ASTM C1289, Type II or Type III
FlintBoard® ISO WF	Composite roof insulation with foam core laminated to 1/2" high density wood fiberboard	ASTM C1289, Type IV
FlintBoard® ISO-T WF	Composite roof insulation with a tapered design to promote positive drainage	ASTM C1289, Type IV
FlintBoard® ISO DD	Composite roof insulation with foam core laminated to 1/4" DensDeck	ASTM C1289, Type VII
FlintBoard® ISO F	Features a closed-cell polyiso core with tri-laminated foil facers on each side	ASTM C1289, Type I
FlintBoard® ISO NB	Composite roof insulation with foam core laminated to 7/16" or 5/8" OSB, also available bonded to plywood	ASTM C1289, Type IV
FlintBoard® CV	Cross-ventilating design specifically for use over sloped unventilated roof decks	ASTM C1289, Type V
FlintBoard® Pre-Cut Crickets	Pre-packaged in triangular sections only (not the entire cricket), each with a right angle to align with CertainTeed's standard 4' x 4' tapered FlintBoard insulation panels	ASTM C1289, Type II

## Fasteners and Insulation Adhesives

Product Name	Description
FlintFast® #12 Screws	Features sharp drill point and tapered wedge entry; corrosion protection and back-out resistance, available in lengths from 1-5/8" to 8"
FlintFast® #14 Heavy-Duty Screws	Heavy-duty drill point fasteners with tapered wedge entry; low-profile head, deep threads; available in lengths from 1-1/2" to 12"
FlintFast® #15 Extra Heavy-Duty Screws	Engineered for lap attachment in higher wind uplift roof assemblies
FlintFast® 3" Galvalume Metal Insulation Plates	Concave, reinforced circular design with low profile, designed for outer perimeter strength with recess for screw head
FlintFast® SIPLD Screws	SIP panel fastener, light-duty drill point for corrugated steel deck and wood applications
Twin Loc-Nail	For base sheet and insulation attachment to lightweight insulating concrete, cementitious wood fiber, and poured gypsum roof decks
FM Fasteners	For base sheet attachment to lightweight insulating concrete, cementitious wood fiber, and poured gypsum roof decks
Do-All Loc-Nails	Shingle or base ply attachment to Loadmaster and Martin Fireproofing Deck Systems
FlintFast® TB-75 Termination Bar	.075" thick aluminum termination bar, comes with sealant edge
FlintFast® TB-90 Termination Bar	.090" thick aluminum termination bar; no sealant edge
ZAMAC Nails	Termination bar anchors
Dow INSTA-STIK™ Adhesive	Single component polyurethane adhesive designed to attach roof insulation to roof decks and substrates
ADCO Millenium One Step™ Foamable Adhesive	One-step, foamable adhesive designed to attach roof insulation to roof decks and substrates

## Edge Metal

Product Name	Description
FlintEDGE® Coping	The coping utilizes a metal chair that functions as both a gutter chair with its raised ribs and as an internal splice plate in the same color and finish as the coping cap. Standard 20-gauge galvanized steel cleat. For wall sizes 6" to 32". UL Classified to meet the ANSI/SPRI ES-1 Roof Edge Standard.
FlintEDGE® Coping+	The coping utilizes a metal chair that functions as both a gutter chair with its raised ribs and as an internal splice plate in the same color and finish as the coping cap. A heavy 16-gauge cleat is available for high wind areas. For wall sizes 6" to 32". UL Classified to meet the ANSI/SPRI ES-1 Roof Edge Standard.
FlintEDGE® Fascia ET	FlintEDGE Fascia ET extruded aluminum retainer features a wide base flange to securely hold down BUR and modified bitumen roofing plies. UL Classified to meet the ANSI/SPRI ES-1 Roof Edge Standard.
FlintEDGE® Fascia GG	FlintEDGE Fascia GG grips the roofing plies without the need for exposed fasteners. Standard face sizes are 6.25", 7.75", 9.25" and 10.75". Custom sizes available upon request. UL Classified to meet the ANSI/SPRI ES-1 Roof Edge Standard.
FlintEDGE® Fascia GS	FlintEDGE Fascia GS is a simple formed gravel stop fascia continuous anchor clip with a concealed splice plate at the joints. Three clip styles to choose from. Standard sizes are from 2.5" to 12".
FlintEDGE® Gutter	FlintEdge Gutter is custom sized to meet your special requirements. Designed with internal straps for smooth, clean lines and ease of installation. External hangers are optional.
FlintEDGE® Downspout	FlintEDGE Downspouts have a factory offset for concealed joints. Factory fabricated starter tubes are available to help channel water into the downspout. Standard or custom elbows help complete the professional appearance.
FlintEDGE® Conductor Heads	FlintEDGE Conductor Heads are factory fabricated in the size and shape to meet your unique requirements. Blanks are cut using Conductor Heads computer-controlled equipment for precise, professional appearance.
FlintEDGE® Scuppers	FlintEDGE Scuppers are factory fabricated in the size and shape to meet your unique requirements. Blanks are cut using computer-controlled equipment for precise, professional appearance.
FlintEDGE® Drain	FlintEDGE Drain Through Gravel Stop is custom sized to meet your special requirements. Designed with internal straps for smooth, Through Gravel Stop clean lines and ease of installation. External hangers are optional.
FlintEDGE® Expansion Joint	FlintEDGE Expansion Joint is a multi-part assembly design to facilitate the horizontal and lateral movement of curbs or roof sections. Roof to Roof – CertainTeed's roof-to-roof expansion joint features a snap-on cap for ease of installation and improved aesthetic appearance. Roof to Wall – CertainTeed's roof-to-wall expansion joint features a metal cap for ease of installation and improved aesthetic appearance.
FlintEDGE® Reglet and Flashing	FlintEDGE Concealed Mount Reglet – The surface-mounted wall reglet permits fastener concealment under the continuous snap-on flashing skirt. An attractive and weatherproof counter flashing design. FlintEDGE In-Wall Drive-Lock Reglet – Two-piece counter flashing system with surface-mounted reglet/receiver punched for fastening 12" o.c. Snap-on metal skirt flashing can be removed for re-roofing or maintenance. FlintEDGE Surface Mount Reglet – Standard one-piece design. Sections easily overlap for continuous counter flashing of wall terminated roofing. Fast installation. Pre-punched fastener holes at 12" o.c. Custom sizes available upon request. FlintEDGE Snap-on Face Reglet – Continuous wall retainer bar secures roofing to the wall or blocking with fastener holes 12" o.c. Snap-on metal fascia cover conceals fasteners. Attractive clean lines with your choice of 24 standard Kynar 500® colors.

## Primers

Product Name	Description	Specifications
FlintPrime®	Solvent-based, highly penetrating asphalt primer designed to promote membrane adhesion for torch, hot or cold applications, or to promote adhesion with self-adhering membranes on recover applications.	ASTM D41
FlintPrime® SA	Water-based, quick drying polymer primer designed to promote self-adhering membrane adhesion to most roofing substrates (not asphaltic recoveries)	

## Adhesives

Product Name	Description	Specifications
FlintBond®	Cold-applied, high strength, asbestos-free, SBS modified asphalt adhesive with excellent adhesive and elongation properties. Available in spray, brush, trowel and caulk grades.	ASTM D3019, Type III

## Coatings

Product Name	Description	Specifications
FlintCoat® – A 300	Premium-grade, self-protecting, moisture-resistant, heat-resistant reflective roof coating. Refined solvents blended with pigment flakes of pure aluminium, mineral fibers and selected asphalts.	ASTM D2824, Type II, ASTM D3805
FlintCoat® – A 150	Professional-grade, self-protecting, moisture-resistant, heat-resistant, long-lasting reflective roof coating. Refined solvents blended with pigment flakes of pure aluminium, mineral fibers and selected asphalts.	ASTM D2824, Type III
FlintCoat® – W	Premium, protective, highly reflective, white, heat-resistant roof coating. Thick, elastomeric acrylic copolymer is highly flexible and resists cracking, peeling and mildew.	ASTM D6083
FlintCoat® – E	Solvent-free (odorless) emulsion roof coating to create a smooth surface on an otherwise rough or cracked asphalt roof surface to support the application of reflective coatings, such as FlintCoat-W.	ASTM D1227, Type II, Class I

## Repair

Product Name	Description	Specifications
FlintPatch®	Asbestos-free wet/dry rubberized flashing cement, compounded with a blend of rubber-reinforced asphalt, mineral fibers and refined solvents in a heavy, pliable consistency for ease of application by trowel.	ASTM D4586 Type I ASTM D3409

## Liquid Flashing and Repair

Product Name	Description
SmartFlash®	High performance, odorless, seamless, self-terminating, two-part urethane-based waterproofing system. Flashpacks available with all tools and material necessary to flash and repair approximately 25 square feet of area.

## Material Handling and Storage

- Store rolls upright on pallet in dry area.
- Store indoors in a ventilated area.
- Keep rolls protected from exposure to heat, sun, cold and moisture.
- Do not double stack pallets.
- Do not store rolls on their sides.
- Use care in the handling of the rolls.
- Do not overload the roof. Stagger the rolls across the roof. Avoid excessive weight in a concentrated area.

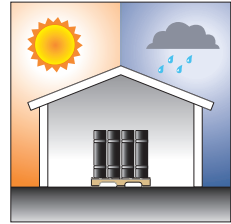

## Weather Precautions

Do not attempt application if weather conditions and substrate are not dry.

Do not attempt application if ice, frost, moisture or snow is present. Rolls can be installed in cold weather if conditions are dry, the rolls have not been allowed to freeze and proper cold weather handling and storage procedures are followed. Store rolls in a heated area until just prior to use and do not proceed with installation if rolls have been allowed to freeze or weather conditions are unsuitable.

In extremely warm weather, use caution when walking on freshly installed material to avoid “tracking” warm asphalt; when torch applying smooth APP membrane in very warm weather the installer may want to utilize a roll puller and work from front side of the roll (as is the standard torch method for SBS membranes) to avoid tracking.

## Roof Slope and Drainage

The roof surface that is to receive the roof membrane shall have slope to water collection devices. A drainage calculation determining the quantity of water that will fall on the roof and how it is to be taken off the roof is a part of good roof design. Model building codes and good roofing practice have established a minimum slope for roofs at 1/4":12 running inches. Codes also recognize the challenges to meet this criterion in reroofing of existing buildings. All roof areas shall be designed and installed to drain without holding water on the roof surface. Water collection on the roof surface can be detrimental to the roof membrane and may void an existing warranty. Water should not pond in drain sumps or any other collection area that is covered in roof membrane. Limited and minor areas of ponding may be accepted by CertainTeed under the terms of the warranty; however, sacrificial surfacing may be required to maintain the warranty.

All roofs shall have an overflow system adjacent to drains or scuppers to collect and direct water off the roof should one or more water collection device fail. Overflows are required by most local building codes and should be incorporated into any roof design.

## Substrate Preparation

All surfaces to which the Flintlastic modified bitumen is to be installed must be smooth, dry, free from dust or debris, free from settling or distortion, and free from cracks, knotholes, or other defects.

### Primer

Concrete decks must be properly primed with suitable asphalt primer (meeting ASTM D-41) and the primer must be thoroughly dry. FlintPrime SA, water-based primer is recommended when installing self-adhering systems.

Metal flashings must also be primed with a suitable asphalt primer for metal, and primer must be thoroughly dry and any solvents evaporated prior to application of membrane flashing.

## Base Sheet Application

In new construction or re-roofing applications, an appropriate CertainTeed base sheet must be installed over the substrate. Unless otherwise specified, base sheet must be overlapped min. 4" at endlaps and 2" at sidelaps. For mechanical attachment of the base ply on insulated steel substrates, the base sheet at a minimum may be fastened with approved fasteners 12" o.c. on 4" side laps and 18" o.c. in two staggered rows in the field of the sheet 12" in from the edge.

For nailable substrates, base sheet must be mechanically fastened in accordance with NRCA standards (fasteners placed every 9" o.c. at sidelaps and every 18" o.c. in two staggered rows in the field of the sheet; the two staggered rows are placed 12" from each sidelap).

For non-nailable surfaces, spot mopping with hot asphalt at the minimum rate of one 12" circle every 24" o.c. in all directions, using appropriate type asphalt at the

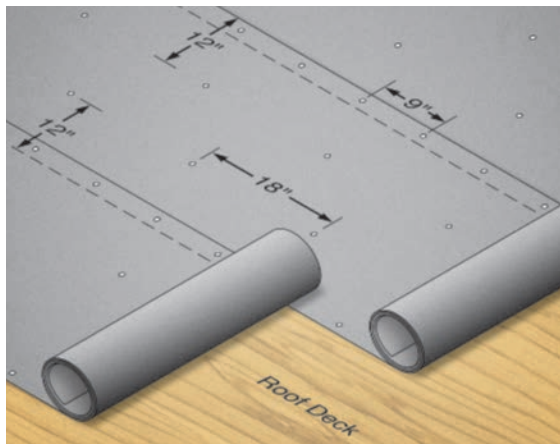

minimum rate of 15 lbs. per square, is the standard spot mopping method. Refer to [www.roofnav.com](http://www.roofnav.com) for specific information regarding Factory Mutual requirements, which may differ per individual specification. Refer also to the “Hot Asphalt Application” section on page 30 of this booklet.

## Vapor Retarders

Refer to the General Recommendations Section of the CertainTeed Commercial Roof Systems manual for more information.

## Insulation

All insulations require the use of appropriate base sheet between the insulation and the new roof system. Insulations must be installed in accordance with CertainTeed’s instructions, local code and Factory Mutual requirements.

In general, the following rigid board insulation types are acceptable for use under Flintlastic modified bitumen Roof Systems (consult CertainTeed for specific Factory Mutual requirements):

### **Fiberglass or mineral wool**

Conforming to ASTM C726 (CGSB 51.31M)

### **Wood fiberboard**

Conforming to ASTM C208 (CGSB 51.26M)

### **Perlite**

Conforming to ASTM C728

### **Extruded polystyrene\***

Conforming to ASTM C578-85-Type IV (CGSB SB-51.20M Type 2-Type 4)

### **Expanded polystyrene\***

Conforming to ASTM C578, Min. 1.1 Density (CGSB 51.26M)

### **Polyisocyanurate**

Conforming to ASTM C1289 Type II.

*\*Expanded polystyrene and extruded polystyrene insulations require a coverboard prior to installation of base sheet. Additionally, taping of insulation joints may be required. Refer to NRCA and CertainTeed requirements. CertainTeed self-adhered base sheets may be directly adhered to mechanically attached, fiber glass faced isocyanurate insulation such as FlintBoard ISO cold. Do not expose flammable or heat sensitive insulations to heat, solvents or flame.*

## Multi-layer Insulation Applications

To reduce thermal stress to the roof membrane, multi-layer applications are strongly recommended. Joints in the insulation layers should be staggered a minimum of 6" and joints should be tightly butted. Where mechanical fasteners are used, only the base layer should be mechanically attached. Subsequent layers should be installed in asphalt or adhesive.

The insulation or coverboard surface used for the installation of membrane shall be planar and free from debris. Any gaps shall be corrected prior to application of membrane. No insulation or coverboard panels should be less than 12" square when adhered or 24" square when mechanically attached.

### **Mechanical Attachment**

All base insulation layers over steel deck shall be mechanically attached with sufficient fasteners and stress plates to meet the uplift requirements for the project. Fastener density shall be increased at perimeters and corners as required by code and the project requirements. At a minimum, fastener density shall be increased by 50% at the perimeters and 100% at the corners, providing there is no parapet with a height less than 36". Fasteners shall penetrate the top flange of the deck a minimum of 3/4". To ensure securement to the deck, fasteners shall be sized to penetrate the bottom flute by 3/4". Fasteners shall be fully seated but shall not be overdriven to damage the insulation or coverboard surface. Fasteners and stress plates shall be installed in compliance with the recommendations of both the fastener and insulation manufacturers. Where holes must be predrilled, such as gypsum and concrete, deck debris must be cleaned from the insulation surface prior to application of the roofing membrane. When projects are insured by or specified under the requirements of FM Global the requirements under the relevant RoofNav number and the related Loss Prevention Data Sheet shall be followed. For more information, visit [www.roofnav.fmglobal.com/](http://www.roofnav.fmglobal.com/).

CertainTeed provides a complete line of FlintBoard roof insulations and reserves the right to accept or reject another manufacturer's insulation as an acceptable substrate for attachment of a CertainTeed Commercial Roof System. CertainTeed Corp. does not warrant performance of another manufacturer's insulation unless such approval is granted in writing by CertainTeed in advance of installation.

### **Recover Considerations**

A recover is the application of a new roof over an existing roof. If a roof installation is a recover, the existing roof assembly must be a suitable substrate for the application. Most codes limit recovers to one additional roof. An evaluation of the combined live and dead loads should be carried out by a structural engineer prior to any application over an existing roof. Loading requirements may have changed since the original roof application increasing the live load requirements due to historical snow loading data.

The existing roof should be evaluated for moisture and for adhesion to the underlying substrate. Adhesion can be evaluation with either a vacuum test or bonded pull test as detailed in the FM Global Loss Prevention Data Sheet 1-52 or the vacuum test detailed in the ASTM E 907<sup>1</sup>. Moisture analysis can

<sup>1</sup>ASTM E 907: Standard Test Method for Field Uplift Resistance of Adhered Membrane Roofing Systems

be either nuclear, capacitance or infrared. All wet roofing materials must be removed prior to any recover.

Should the existing roof be used as a bonding substrate, the surface must be properly prepared for the application of the new roof or insulating layer. Loose and large gravel shall be removed; blisters and splits shall be repaired and existing flashings should be removed to create a clean bonding surface for new elements. Where the new roof is mechanically attached to the underlying substrate, withdrawal resistance testing should be carried out to confirm the attachment values for each fastening point. Testing should be carried out in compliance with ANSI/SPRI FX-1-2006 or TAS 105. Copies of the test protocols are available from CertainTeed Technical Services. Fastener values should meet or exceed 325 lbf or the fastener density should be increased. The test data shall be evaluated by the roof designer of record for the evaluation of the fastening pattern. CertainTeed Technical Services can provide test data for a wide variety of system to assist in the evaluation.

Areas of ponding shall be corrected prior to the installation of a recover roof. Fillers designed to fill low spots should be used to correct these conditions. For a list of available products, please contact CertainTeed Technical Services.

It is the responsibility of the designer of record, and/or building owner to determine whether an existing roof is structurally sound, firmly attached, dry and suitable for recover. CertainTeed Technical Services can provide additional warranty information for specific recover projects.

### **Preparation and Field Conditions**

The following requirements shall be used in conjunction with good roofing practices to qualify a new assembly for the NDL Limited Warranty or the Limited Product Warranty Program:

1. Deck shall be dry, structurally sound and suitable for the application of the roof assembly.
2. Parapet walls, perimeter edges, equipment and load bearing supports, platforms, curbs, etc., shall be structurally sound and suitable for the application of the flashings and terminations.
3. Existing roof assemblies should be evaluated to determine if additional expansion or control joints are needed. Visual observations of wall cracks, membrane splits and materials out of plane are indicators of such conditions.
4. The designer of record should evaluate combined live and dead loads to insure the recover roof assembly meet current code criteria and sound engineering practice.



5. Existing plywood decking shall have adequate bearing or support of end joints. In recover applications, remediation of the joints can only be achieved from the underside of the deck.
6. All recover roofs shall have positive drainage as defined on page 9.
7. Existing roof insulation shall be dry and firmly attached. Where existing insulation is found to have insufficient attachment, attachment of the existing system shall be enhanced.
8. Existing roof system shall be compatible with new roof system.
9. Existing membrane shall be dry and clean with all surface defects corrected.
10. Existing roof surfacing with 1/2" or larger aggregate surfacing shall be torn off or spudded to provide a smooth surface. Notwithstanding the gravel sizing, all loose gravel shall be swept from the existing roof surface.
11. Remove existing metal gravel stops and other termination flashings and replace with new metal to meet current code. Flashing metals shall be corrosion resistant and shall not be thinner than 24 ga.
12. Existing counterflashings, copings, dunnage protectors, protective caps and other flashing metals designed to protect the roof shall be replaced where unsuitable for reuse. New metals shall be corrosion resistant and shall not be less than 24 ga.
13. Remove all clamping rings from drains and clean to bare metal. Damaged drain components shall be discarded and replaced with new. When in good condition, clamping rings may be saved for reuse. All bolts shall be replaced with new, preferably formed from non-ferrous materials. Stripped bolt holes shall be drilled and tapped. All drains shall be fully secured to the deck with under deck clamps or other factory supplied clamping systems.
14. All abandoned and non-functioning equipment shall be removed. Any resulting deck opening shall be blocked and closed with appropriate decking.
15. Flashing heights shall be a minimum of 8" from the surface of the roof membrane. Where flashing terminations may be subjected to snow cover, the flashing shall be sealed.
16. Base and wall flashing shall be removed to create a sound surface for the installation of new flashings.
17. All roof penetrations require all new flashings in compliance with current CertainTeed detailing.

18. Equipment vibration shall be corrected.
19. Masonry surfaces above flashings shall be tuck-pointed and sealed. All horizontal masonry surfaces above the roof membrane shall be adequately protected from weather.
20. All pipes and condensation line supports shall be properly supported with factory supplied pipe supports or pressure treated woodblocking. All supports shall have a protection layer of not less than one layer of Flintlastic modified bitumen membrane. The support shall be designed to allow for pipe movement and shall not be secured through the roof membrane.
21. Condensation lines shall be formed from ultraviolet light resistant materials and shall terminate at drains or scuppers. Condensate shall not run on the roof surface.
22. The practice of installing only a part of a total roof assembly, known as phasing, can be harmful to the finished roof assembly. CertainTeed will not warrant phased applications.

**NOTE: Substrates with two or more existing membranes are not eligible for a CertainTeed Warranty. Extended warranties require new construction and/or complete tear-off.**

### **Application Over an Existing Membrane**

After preparing and priming the existing membrane surface spot mop with type III or type IV asphalt, forming 12" circles spaced 24" o.c., and install a Yosemite Venting Base Sheet with side laps of 2" and end laps of 6". Asphalt quantity shall be 15 lbs. per square, or greater, depending on the roughness of the existing membrane surface. Granules and grooves shall be facing down. Alternatively, mechanically attach a Yosemite Venting Base Sheet with minimum #12 diameter roofing fasteners and 3" stress plates to meet the design uplift criteria. At a minimum, mechanical attachment shall be placed 12" o.c. on a 3" lap and two staggered rows in the center of the sheet spaced 18" o.c.

Insulation shall be solid mopped to buffer sheet. Alternate base sheets may be approved on a job-by-job basis. Contact CertainTeed Technical Services with project data for consideration of alternate base sheets. Rigid insulation may be applied directly to an existing built-up membrane providing the surface has been properly prepared; there is adequate attachment of the existing roof assembly to resist design and/or code require loads and the deck has been adequately leveled to provide full adhesion of the maximum 4' x 4' insulation boards. An initial glaze coat of asphalt can fill minor variations in the deck surface and provide a more suitable surface for the application of rigid insulation board.

## Roof Relief Vents

If roof relief vents are deemed appropriate they should be of a suitable type with minimum 4" flange and weather resistant hood, spaced 20' from roof edge perimeter and every 40' o.c. thereafter.

## Proper Tools

To the professional roofer, the importance of proper tools is understood. However, here's a brief recap of the ideal tools for applying Flintlastic modified bitumen:



- For torch applications, a U.L. listed torch designed specifically for the application of modified bitumen membrane with U.L. listed high-pressure hose, and U.L. listed regulator. Use an appropriate length field torch for applying the field roof membrane, and a “detail” torch for accomplishing flashing details.
- Propane tank with pressure gauge.
- At least one ABC type fire extinguisher, fully charged (min. 20 lbs.) per each operating torch and the appropriate number of fire extinguishers at the kettle area if hot asphalt is used.
- For hot asphalt applications, appropriate asphalt heating, handling and application equipment. Mop size should be not less than 32 ounces.
- For self-adhering applications, 18" wide, 2"- 4" diameter industrial steel roller for pressing membrane into place; long-handled (standing) roller with 1/8" -1/4" nap for applying primer (1/8" nap for smooth surfaces, 1/4" nap for more porous surfaces); caulk gun for applying beads of FlintBond adhesive; hand-held hot air welding gun such as the Leister Triac™ (110 volt power required) or Primus Sievert PNS-4™ Hot Air Kit; seam probing tool to check for small voids.
- A roofer's hooked blade knife (the hooked blade is ideal for cutting the membrane).
- A roofer's trowel with beveled edges and rounded tip (allows smoothing of details without cutting or marking the membrane); trowels that allow adequate room between the roofer's gloved fingers and the warm membrane are the best.

## Proper Attire

- Long pants and long sleeved shirts.

- Leather work shoes with synthetic or smooth leather soles.
- Leather work gloves that adequately shield the wrist area. Refer also to the “Safety” section on page 53 for information regarding proper work attire.

## Roof Layout

As with most types of roof installations, Flintlastic modified bitumen roof installation begins at the low point of the roof with successive rolls installed so that no laps are against the flow of water. When membrane is applied with hot asphalt, where roof slope is 1" per foot or less, sidelaps are installed perpendicular to the direction of the roof slope. In situations where the roof slope exceeds 1" per foot, rolls are installed with the sidelaps running parallel to the slope direction. APP modified membranes can be installed with sidelaps perpendicular to the slope where roof slope is 2" per foot or less (over 2" install sidelaps parallel to roof slope direction).

Additionally, where roof slope exceeds 1" per foot for SBS modified and self-adhering membranes or 2" per foot for APP modified “back-nailing” of membrane is required. Refer to the General Recommendations section of the CertainTeed Commercial Roof Systems Manual for back-nailing guidelines.

Endlaps are to be staggered. In multi-ply applications, membrane sidelaps must also be staggered.

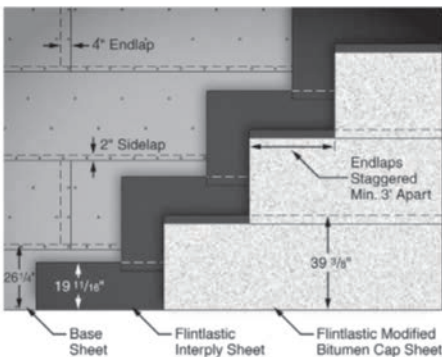

**In multi-ply systems, stagger sidelaps from interply and base sheet sidelaps**

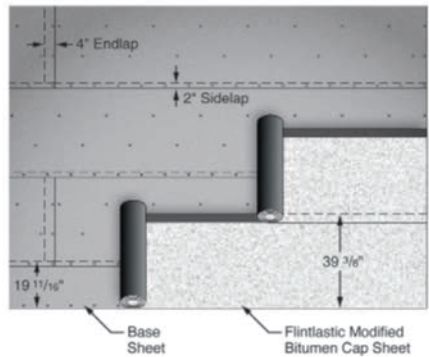

**Stagger field sidelaps from base sheet sidelaps**

**Warning:** Flintlastic Modified Bitumen application may require the use of hot asphalt and/or an open flame roofing torch. Improper application practices may cause physical injury to the applicator or damage to the property. Refer to the current CertainTeed Commercial Roof Systems Manual for further information.



Proper torching procedure involves passing the torch flame in an “L” pattern across the coiled portion of the roll and up the sidelap area. As subsequent rolls are installed, heat is applied both to the roll and the exposed laps of the membrane being overlapped onto. As it is heated, the roll becomes shiny and the polyethylene film melts away. Adequate heat is confirmed when a uniform flow of melted bitumen compound flows evenly in a 1/4" -1/2" uniform bead that oozes from the applied membrane’s edges. Be sure to heat the entire roll evenly, not just the lap areas, with extra concentration at the laps. Once at the end of the roll, re-roll the untorched half, pulling back to beyond the starting point as much as possible, and repeat the torching procedure.

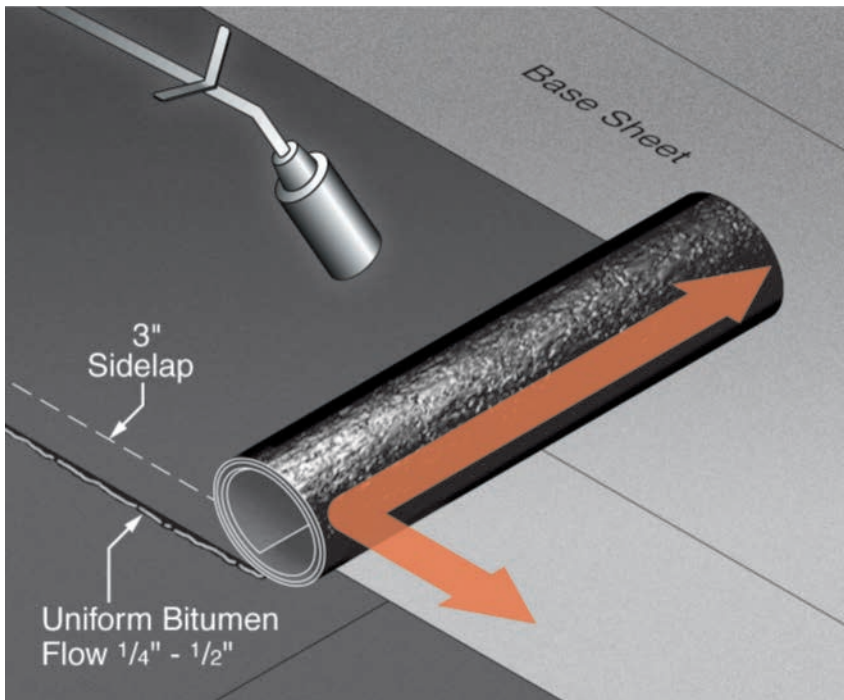

**Proper torching, in an “L” pattern, assures uniform 1/4" -1/2" compound and flow at laps and adequate heat across the coil**

Trim the lower outside corner of the roll at an angle as shown. Overlap subsequent rolls 3" at sidelaps (or as specified, min. 3") and 6" at endlaps. Sidelap lines are generally indicated for the applicators' convenience.

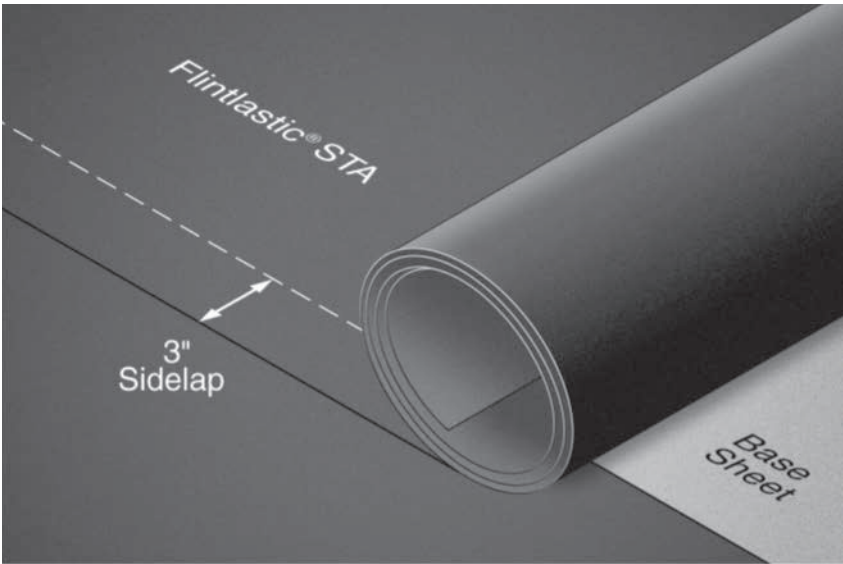

**Overlap Flintlastic STA sidelaps a minimum of 3"**

Trim the upper outside corner of the subsequent rolls as shown. All trimmed corners will be covered with the subsequent rolls.

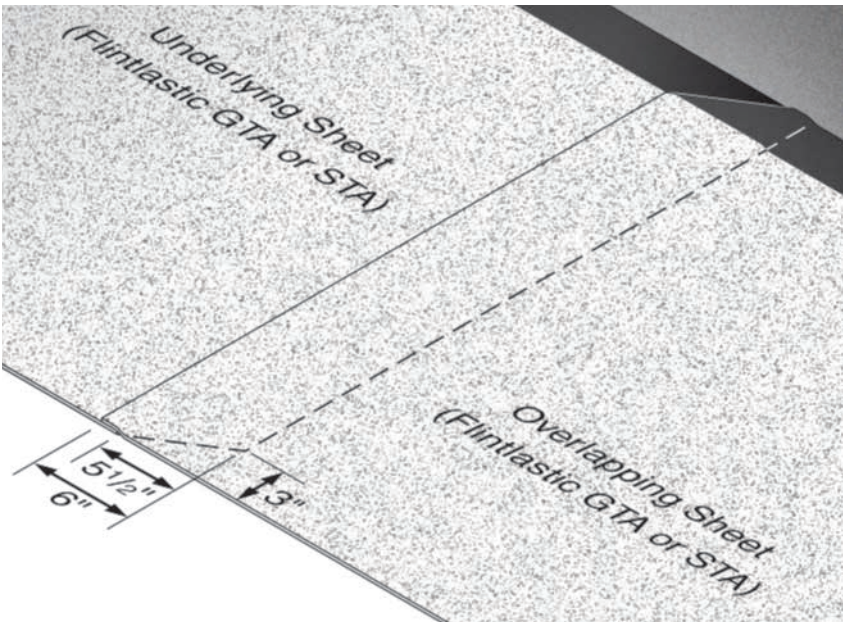

**Endlap cuts are made at an angle as shown**

It is critical (especially at the lap areas) to apply adequate heat to both the membrane being installed and the area of membrane being overlapped onto. Granulated APP membranes require treatment of the underlying lap granules by heating and removal or heating and pressing to insure a proper end lap weld. A warm trowel should be used to check laps for an adequate seal. Any unbonded areas must be lifted and retorched. Do not attempt to reseal by torching the top surface of the membrane.

### Flashing Details: Flintlastic APP Modified Bitumen

Flashing details are accomplished using cut pieces of Flintlastic APP modified bitumen in combination with appropriate prefabricated flashing components. The same sidelap and endlap rules apply to flashing details as to field membrane.

Examples of typical flashing details are as follows:

#### Parapet Wall

Noncombustible cant strip must be installed at the base of the parapet wall. Field membrane plies must extend a minimum of 2" beyond the top of the cant strip.

For nailable walls, appropriate base sheet must also cover parapet wall and extend to the top of cant strip. Base sheet extends over the top of parapet and is mechanically fastened.

Parapet wall flashing membrane (Flintlastic APP modified bitumen) not exceeding roll width must extend to the outside edge of the parapet wall if coping is used, or a minimum of 8" above the top of the cant strip if termination bar and counterflashing are installed, and a minimum of 4" onto the completed field membrane.

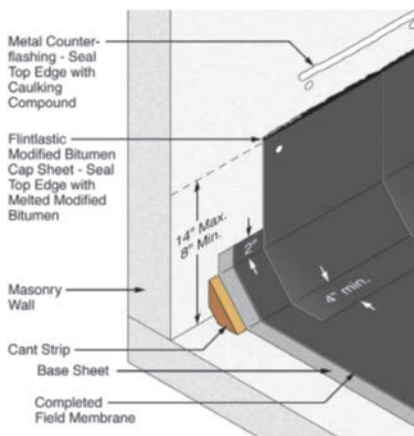

Concrete wall with metal counterflashing

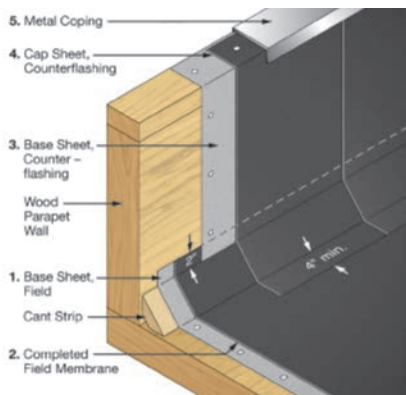

Wood parapet wall with metal coping



### Parapet Inside Corners

Base of corner: Make a “V”-shaped cut in the Flintlastic APP modified bitumen membrane to permit it to conform to the inside corner fold (both sides of the “V” will neatly overlap when folded into the corner). Use a trowel to press the heated membrane flaps into place. Top of corner: Cut a notch part way to permit the top of the membrane to conform to the inside corner and fold over the top of the parapet. Cap the resulting gap with a strip of Flintlastic APP modified bitumen.

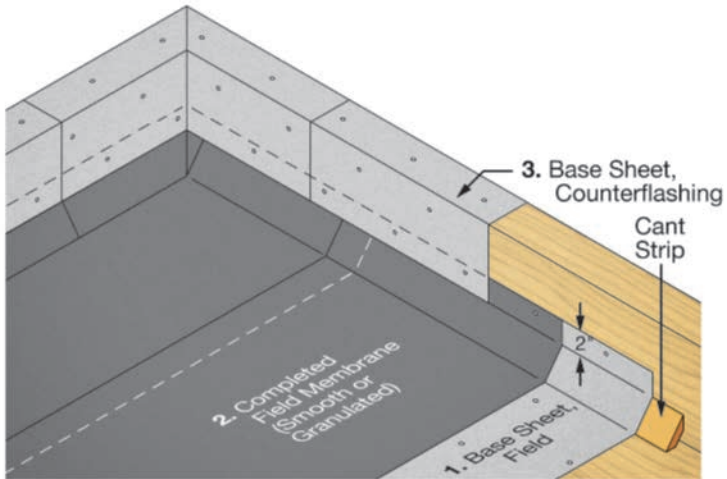

Inside corner (parapet) detail, torch applications - part A

#### V-Cut in Membrane to Accommodate Fold

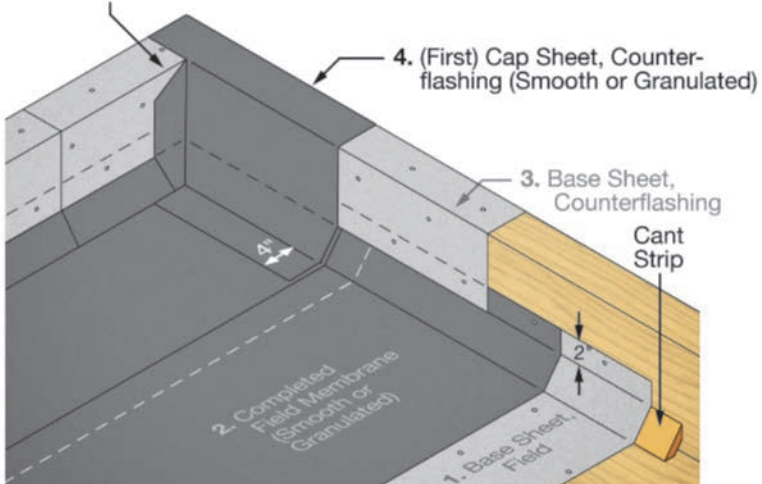

Inside corner (parapet) detail, torch applications - part B

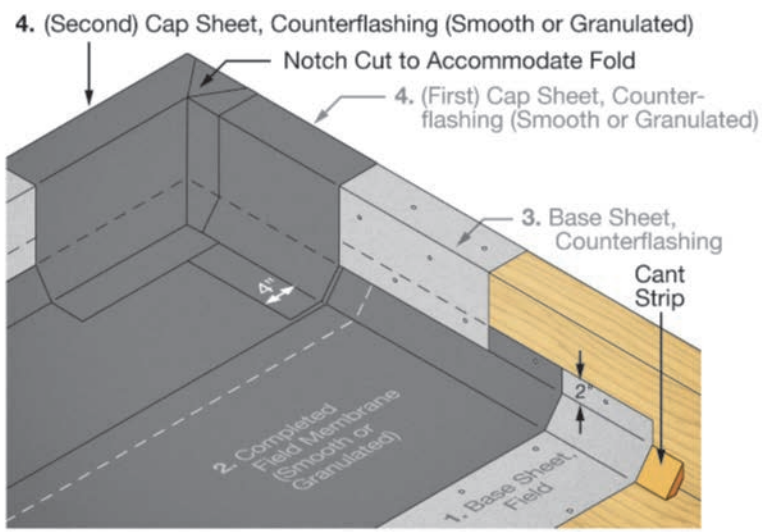

Inside corner (parapet) detail, torch applications - part C

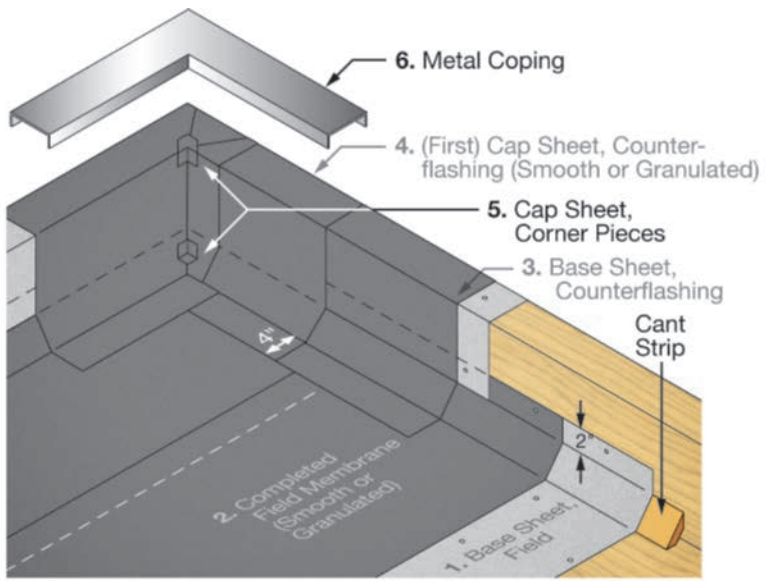

Inside corner (parapet) detail, torch applications - part D

## Outside Corners and Curbs

At outside corners such as curbs, the reverse situation occurs from that of inside corners. The “V”-shaped cut goes at the top of the membrane strip and the notch or straight slice at the bottom, since the membrane is folding the opposite way.

In this case, cap the opening at the bottom of the strip which extends onto the field of the roof a minimum of 4”

**Note:** Completed field membrane shall be extended 2” above top edge of cant and solid attached to cant strip only.

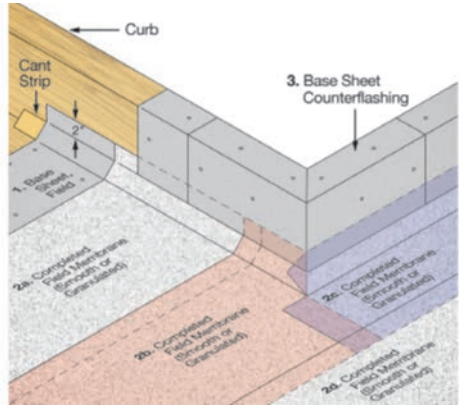

Outside corner (or curb) detail, mineral surfaced torch applications - part A

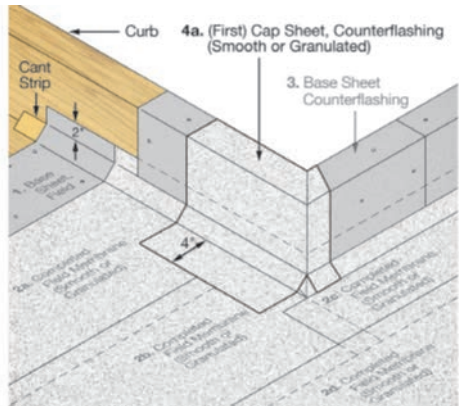

Outside corner (or curb) detail, mineral surfaced torch applications - part B

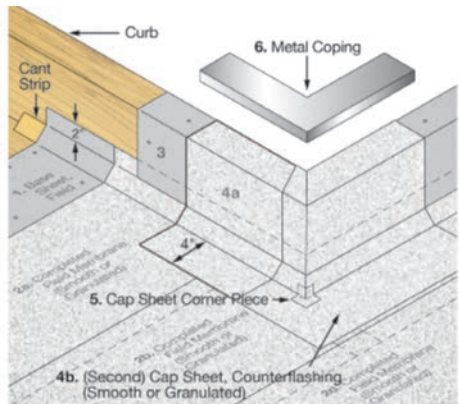

Outside corner (or curb) detail, mineral surfaced torch applications - part C

### Metal Edge Detail – Mineral Surfaced Applications

Base sheet must extend over fascia a min. of 2". A min. 9" wide strip of flashing membrane (Flintlastic APP modified bitumen) should then be applied to the base sheet, flush with the roof edge and extending 9" onto the field of the roof.

Appropriate edge metal (min. 26 gauge, primed) must be properly installed and secured (in two rows, spaced every 6" staggered, fasteners placed every 3"). Finally the mineral surfaced Flintlastic APP modified bitumen cap sheet is installed securely over the 4" edge metal face (continuous from the field of the roof).

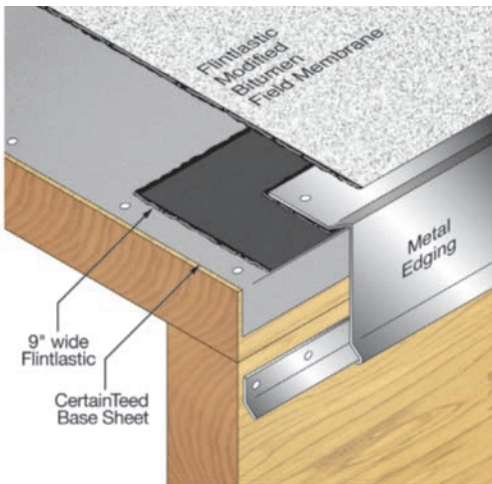

Metal edge details, Flintlastic GTA granule surfaced APP Modified Bitumen Membrane

### Metal Edge Detail – Smooth Surfaced Applications

Base sheet must extend over fascia a min. of 2". Next, the smooth surfaced Flintlastic APP modified bitumen field membrane is installed, cut flush with the roof edge. Appropriate edge metal (min. 26 gauge, primed) must be properly installed and secured.

A min. 10" wide strip of Flintlastic APP modified bitumen smooth surfaced membrane should then be applied over the metal (flush to the roof edge and extending a min. of 6" onto the field of the roof past the portion of the metal which rests on the field membrane).

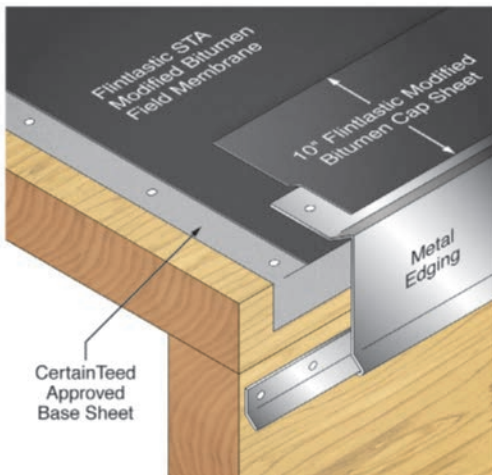

Metal edge detail, Flintlastic STA smooth surfaced APP Modified Bitumen Membrane

## Drains – APP

A strip of Flintlastic APP modified bitumen large enough to extend a min. of 4" beyond the lead flashing edge in all directions (min. 40" x 40") is applied to the base sheet at the drain area. A min. 30" x 30" lead flashing is installed next. Over the primed flashing the field roof membrane is applied in normal fashion. The drain opening should be cut out while the membrane is still warm and the edges sealed. Lead flashing is peened flat against drain bowl sides. Set the drain cap in place and secure the clamping ring. If two field plies of Flintlastic APP modified bitumen membrane are used, the first field ply takes the place of the 40" x 40" flashing ply.

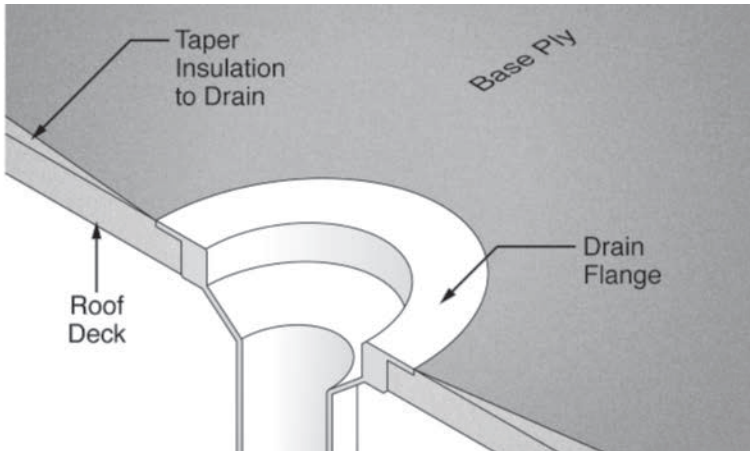

Drain detail, torch applications – part A

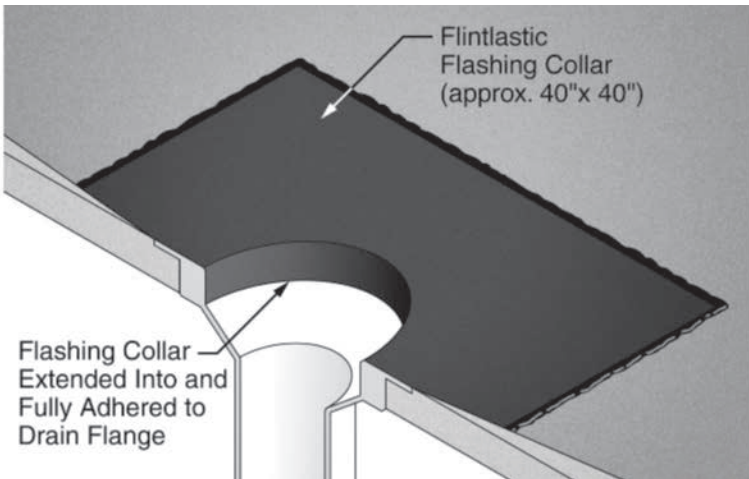

Drain detail, torch applications – part B

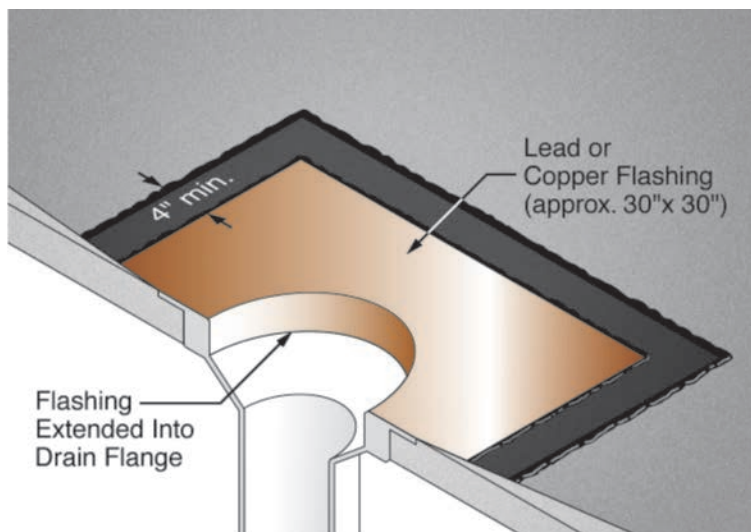

Drain detail, torch applications - part C

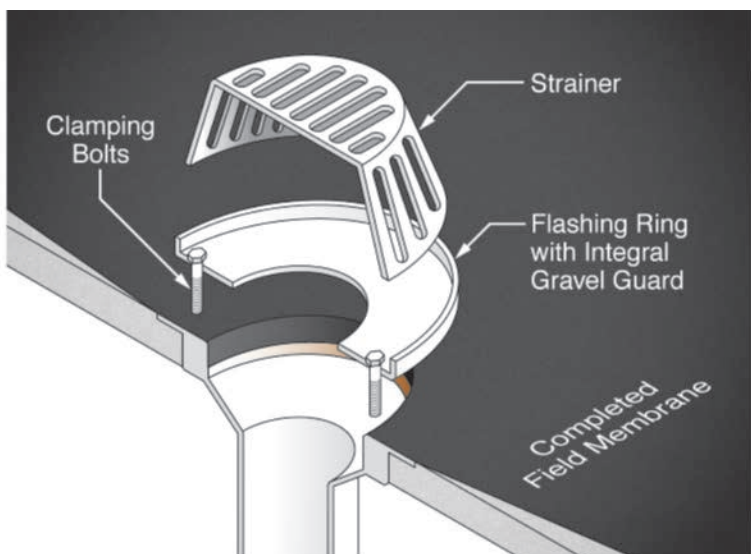

Drain detail, torch applications - part D

## Vent Pipes

Position the smooth Flintlastic flashing on a piece of membrane and mark the dimensions of the vents. Cut a hole corresponding to the pipe size so that a snug fit is achieved. The membrane strip must be large enough to extend a min. of 4" beyond the outside edge of the vent pipe flashing flange

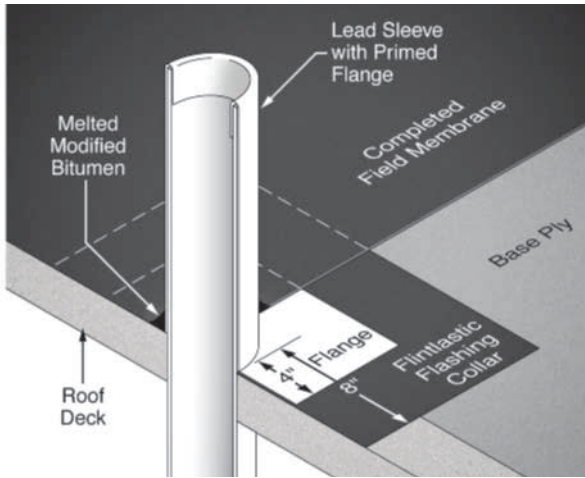

Vent pipe detail, torch application membrane

in all directions. Heat the underside of the membrane strip and press into place. Install the vent pipe collar and secure 3" o.c. around perimeters. Over this the Flintlastic field membrane is applied. Seal the base of the pipe collar with melted modified bitumen.

## Scuppers

The scupper flange is positioned between the base ply and the Flintlastic field membrane, securely fastened. The field base ply extends a min. of 2" above the cant strip. The parapet wall base ply extends from the top outside edge of the parapet over the field base ply to the top of the cant strip, securely fastened. Install scupper, securely fastened 3" o.c., in a bead of sealant. The field ply or plies (on top of the scupper flange) also extend a min of 2"

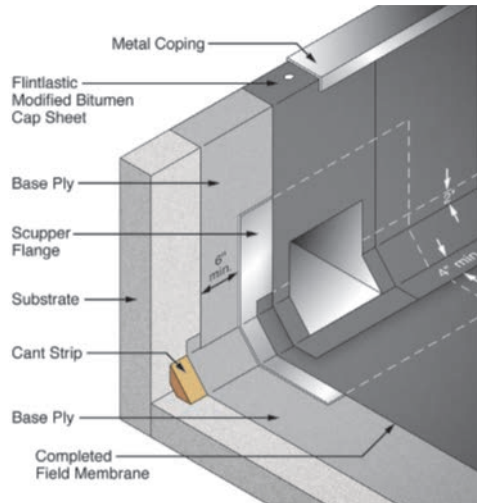

Scupper detail, torch applications

above the cant strip. Cut out scupper opening as necessary. Field membrane is fully adhered and edges sealed. Over this, install a cap of fully adhered Flintlastic APP modified bitumen membrane that covers the top of the parapet and extends down the parapet wall and a minimum of 4" onto the field of the roof. Secure membrane 9" o.c. through tin discs along top of parapet. Again, cut out scupper opening and seal membrane edges. Install parapet wall metal coping.

### Basic Application: Flintlastic SBS Modified Bitumen

Prepare the substrate as described on page 11. Flintlastic SBS modified bitumen can be applied in either hot asphalt, cold SBS modified bitumen adhesive or using a professional roofer's torch. Do not use hot asphalt or cold adhesive for applying polyethylene backed Flintlastic SBS modified bitumen (use torch application method).

### Hot Asphalt Application

Roofing asphalt shall conform to ASTM D-312 Type III (slopes up to 1"/ft.) or Type IV (slopes up to 3"/ft.) Asphalt must not be heated to or above the actual flash point. Asphalt should not be heated and held above the finished blowing temperature for more than 4 hours.

All moppings shall be uniform and free from voids. Bitumen temperature shall be at the Equiviscous Temperature (EVT)  $\pm 25^{\circ}\text{F}$ , at the point of application (minimum  $425^{\circ}\text{F}$ ). EVT is defined as the temperature at which asphalt attains the proper viscosity for application (this information is typically found on the product labeling).

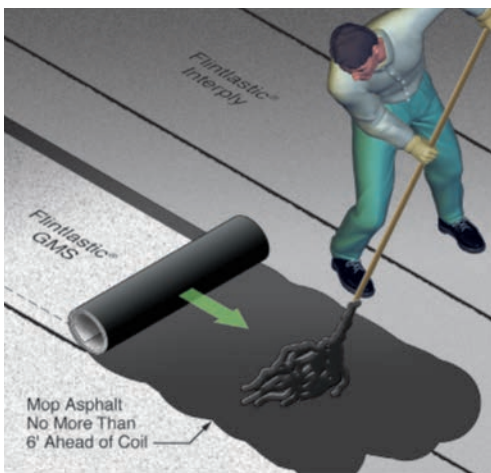

**"Hot mop" application of Flintlastic GMS Modified Bitumen Cap Sheet**

Adequate heat at the point of application is critical to proper adhesion of the membrane plies. Apply asphalt uniformly and evenly without voids; a small bead of asphalt should be visible at all lap areas. Solid moppings require a min. of 25 lbs./100 ft<sup>2</sup> hot asphalt application. Spot mopping of base sheet, when appropriate, is generally accomplished using a minimum of 12" diameter circles spaced every 24" o.c. in three staggered rows. (Certain Factory Mutual listed specifications may have different requirements; refer to [www.roofnav.com](http://www.roofnav.com) for complete details).



Excessive, prolonged heating of asphalt can have a detrimental effect on the integrity of the product. Additionally, excessive heating of asphalt poses a serious flash or fire hazard. Refer also to the “Safety” section beginning on page 52 of this handbook for more information.

The following chart shows guidelines for heating of asphalt by type (Type III and IV):

**NRCA published guidelines regarding heating and slope restrictions for mopping grade roof asphalt**

ASTM D312 Type	Mopping Temp.	Heating Temp.	Maximum Slope*
Type III	425° F +/-25°F	500°F	≤ 1"
Type IV	425° F +/-25°F	500°F	≤ 3"

\*CertainTeed recommends use of Type IV asphalt for interply moppings regardless of slope

**Cold Adhesive Application**

FlintBond SBS modified bitumen adhesive shall be used to apply Flintlastic SBS modified bitumen membranes, Flintglas Cap sheets and coated base sheets. FlintBond shall not be used with APP and SBS modified bitumen membranes designed for torch applications or Flintglas ply sheets.

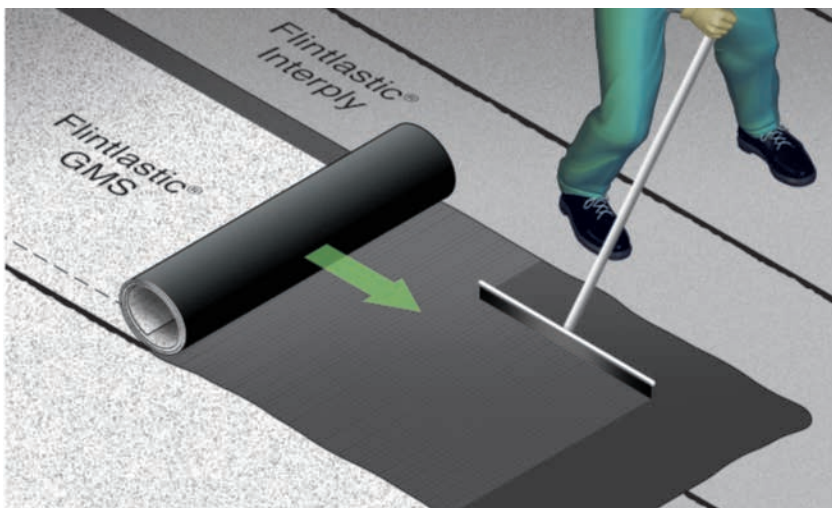

**Flintlastic GMS can be applied using FlintBond SBS Modified Bitumen adhesives (squeegee method shown)**

Strict attention must be paid to weather and climate limitations, application method and technique, curing time, application rates (gallons/100 ft<sup>2</sup>), handling and storage. These requirements are outlined in the technical data sheets. Proper squeegee or spray equipment must be used. Do not use modified bitumen adhesives in areas without proper ventilation.

Membrane application requirements such as endlap and sidelap widths, number and order of plies and flashing details are the same for both hot and cold applications.

### **Interply or Mid-ply Application**

If the Flintlastic SBS modified bitumen specification calls for interply layers, begin membrane application by unrolling the roll and aligning the sidelaps. Re-roll the roll halfway. Standing on the unrolled portion to prevent shifting, begin hot asphalt application\* to the substrate at the rate of 25 lbs./100 ft<sup>2</sup>. Do not apply asphalt more than 6' in front of the roll at any time to prevent premature cooling. Overlap subsequent rolls with appropriate sidelaps and endlaps as specified in the CertainTeed Commercial Roof Systems Manual for the Flintlastic SBS modified bitumen product being used.

### **Cap Sheet Application**

Begin Flintlastic SBS modified bitumen membrane cap sheet application by unrolling the roll and aligning the sidelaps. Re-roll the roll halfway. Standing on the unrolled portion to prevent shifting, begin hot asphalt application\* to the substrate at the rate of 25 lbs./100 ft<sup>2</sup>. Do not apply asphalt more than 6' in front of the roll at any time to prevent premature cooling.

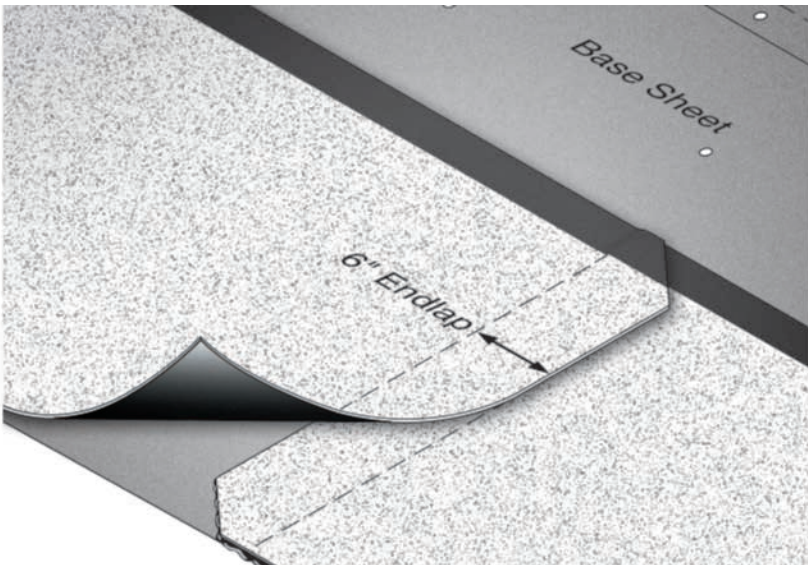

**Overlap Flintlastic Cap sheet endlaps a minimum of 6"  
(Note: cut endlap corners as shown on page 20)**

Overlap subsequent rolls with 3" sidelaps and 6" endlaps. Cap sheet sidelaps must be staggered from the interply sidelaps. Endlaps must be staggered a min. of 3' apart.

For cold adhesive application, use the mop and flop method and back mop all side and end laps. Roll all side and end laps with a seam roller upon completion of the work. (\*Or substitute appropriate SBS modified bitumen adhesive as described on page 31).

### Flashing Details: Flintlastic SBS Modified Bitumen

Flashing details are accomplished using cut pieces of Flintlastic SBS modified bitumen (base flashing and counterflashing strips), sometimes in combination with appropriate prefabricated flashing components.

The flashing and counterflashing membrane are set in either hot asphalt or appropriate SBS modified bitumen elastomeric flashing cement, or torch applied. The same side and endlap rules apply to flashing details as to field membrane. Examples of typical flashing details are as follows:

#### Shingle Roof Transition

Existing shingles must be removed and replaced to accommodate this detail. At transitions from a “flat” roof section to a sloped, shingle roof section the completed Flintlastic SBS modified bitumen roof system must extend a min. of 18" up the sloped section, past the transition point. (Note that the base sheet must first be installed, extending up the sloped section

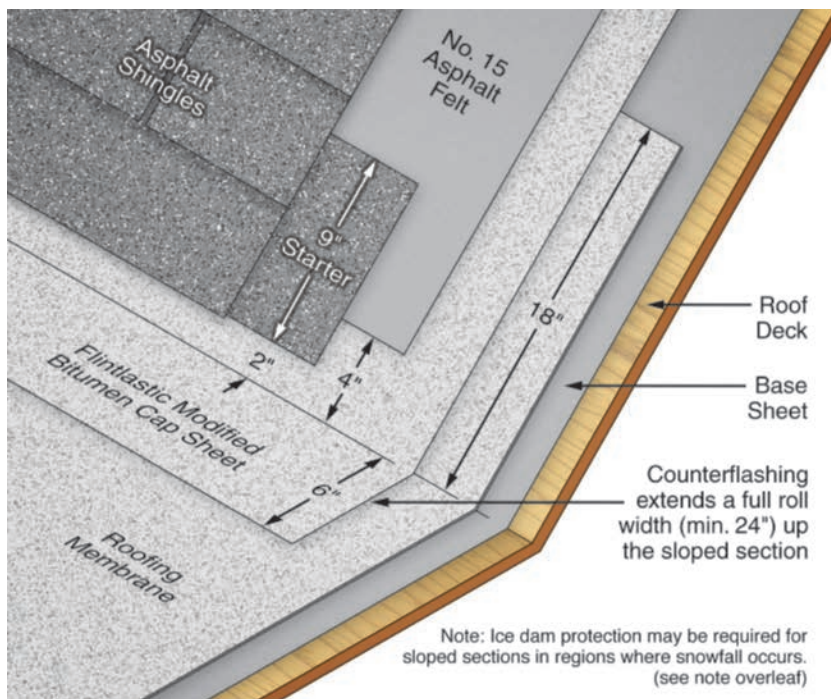

Shingle roof transition

section a min. of 2" past the line where the membrane counterflashing will end so as not to torch or mop directly to the deck.) Next, at the transition area, a min. 30" counterflashing strip of Flintlastic SBS modified bitumen cap sheet must be fully adhered. Position the counterflashing strip so that it extends 6" onto the exposed field membrane and a min. of 24" up the sloped section of roof (min. 6" beyond the turned up field membrane). Over the Flintlastic SBS modified bitumen flashing plies the CertainTeed No.15 Asphalt Felt or Roofers' Select™ shingle underlayment is mechanically fastened, beginning 4" above the transition area. Next the shingle starter row and first course of shingles are installed, beginning 2" above the transition area.

**Note:** In regions where snowfall occurs, install CertainTeed WinterGuard™ or Black Diamond™ Base sheet to the sloped section prior to installation of the asphalt shingles, overlapping the base flashing a minimum of 4" and set in FlintBond Trowel grade.

### Parapet Wall

Noncombustible cant strip must be installed at the base of the parapet wall for SBS torch-applied systems. Appropriate CertainTeed base sheet and all field membrane plies must extend a min. of 2" beyond the top of the cant strip. For nailable walls, also install base sheet from the top of the cant strip to the outside edge of the parapet wall. Parapet wall flashing membrane (Flintlastic SBS modified bitumen) not exceeding roll width must extend to the outside edge of the parapet wall if coping is used, or a min. of 8" above the top of the cant strip if termination bar and/or counterflashing are installed, and 4" onto the field membrane.

### Drains - SBS

The CertainTeed base sheet should extend into the drain, set in hot asphalt or SBS modified bitumen flashing adhesive in a 9" area around the ring and

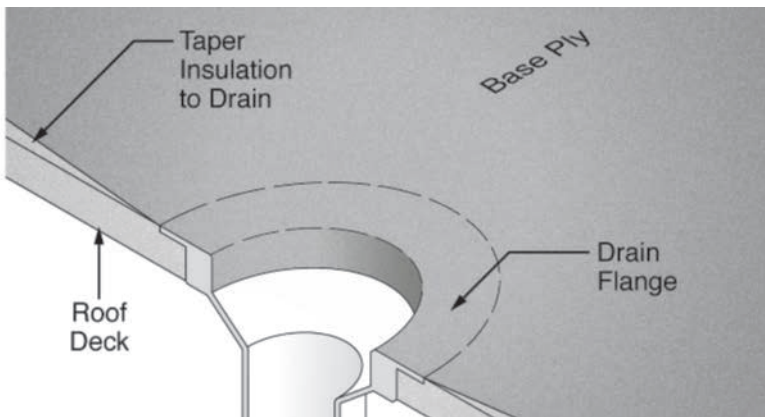

Drain detail, hot asphalt applications - part A

flange. A strip of Flintlastic SBS modified bitumen membrane large enough to extend a min. of 4" from the lead flashing edge (min. 40"x 40") in all directions is applied over the base sheet, with the drain hole cut out.

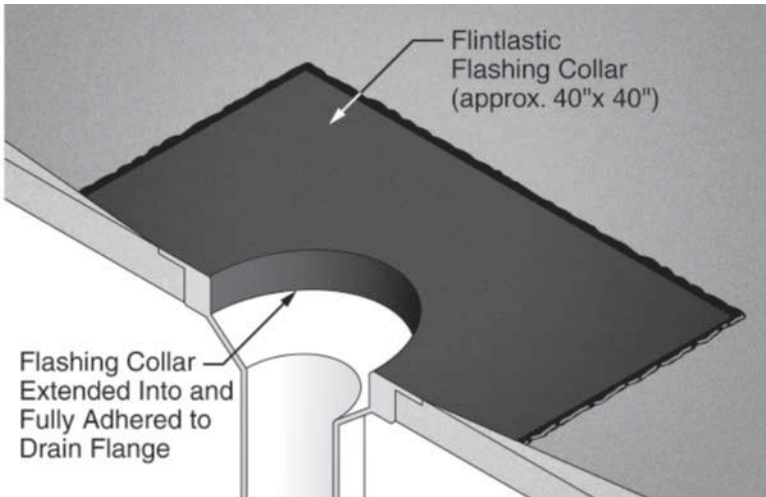

**Drain detail, hot asphalt applications - part B**

A min. 30"x 30" lead flashing set in compatible flashing compound is secured next. Over this, the field roof membrane is applied in normal fashion.

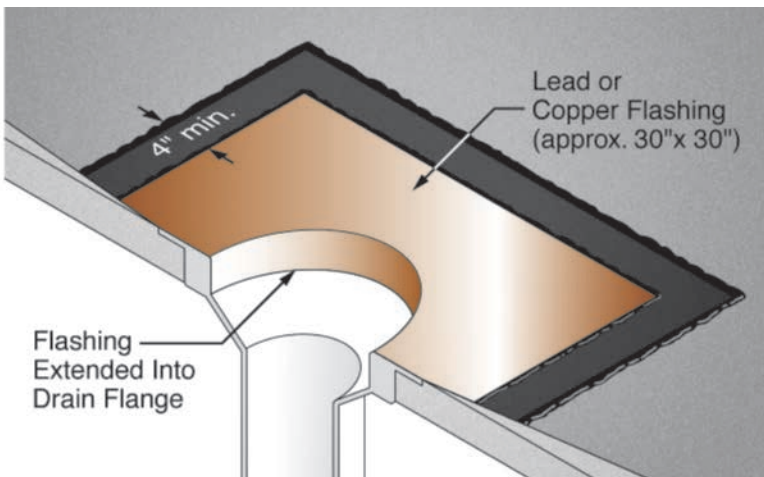

**Drain detail, hot asphalt applications - part C**

The drain opening should be cut out while the membrane is still warm and the edges sealed (allow the Flintlastic SBS modified bitumen membrane to extend into the drain, well adhered). Lead flashing is peened flat against drain bowl sides. Set the drain cap in place and secure the clamping ring while the membrane is still warm.

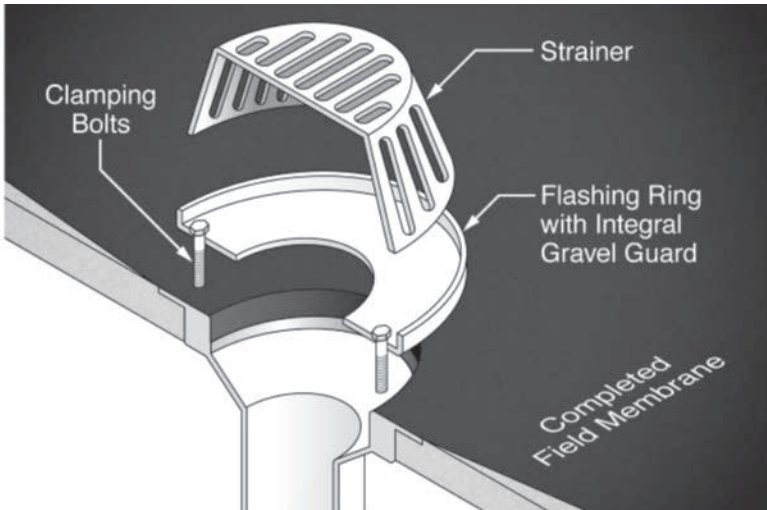

**Drain detail, hot asphalt applications - part D**

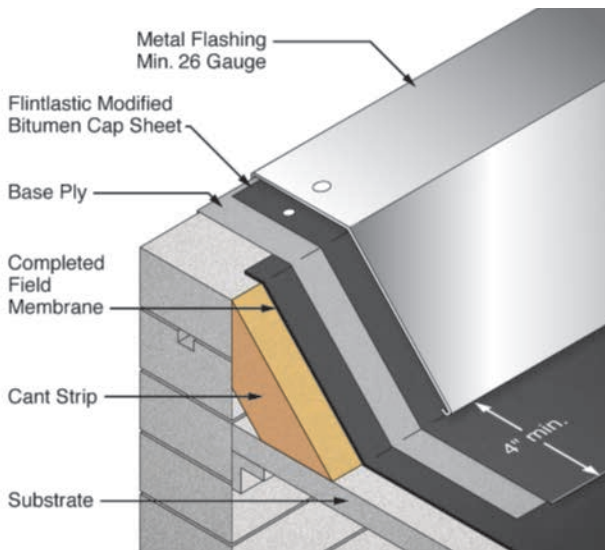

**Example of raised curb detail**

## Vent Pipes

After installing the base sheet, position a piece of smooth Flintlastic membrane and mark the dimensions of the vents. Cut a hole corresponding

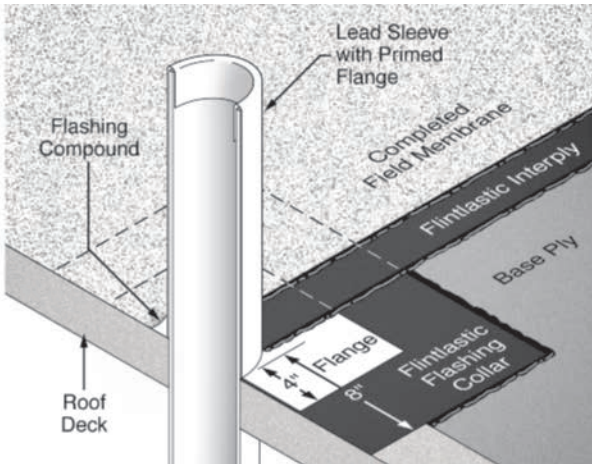

**Vent pipe detail, hot asphalt applications**

to the pipe size so that a snug fit is achieved. The membrane piece must be large enough to extend a minimum of 4" beyond the outside edge of the vent flange in all directions. Secure the membrane strip using hot asphalt or SBS modified bitumen flashing adhesive and press into place. Install the vent pipe collar, properly fastened. Install the Flintlastic SBS membrane. Use modified bitumen flashing adhesive to seal the base of the vent pipe where the field membrane ends.

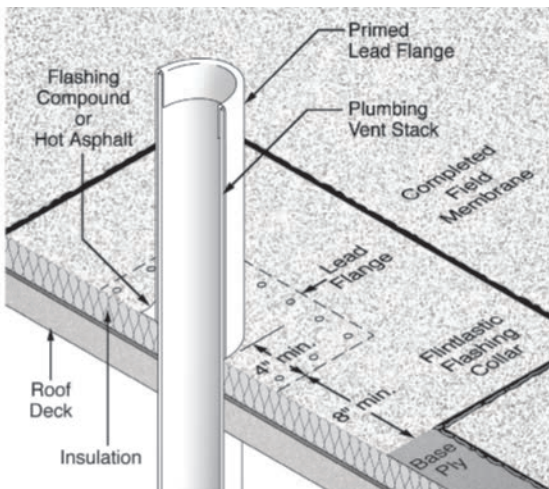

**Alternate detail, lead pipe flashing**

## Basic Application: Flintlastic SA Modified Bitumen

### Important Application Considerations

- Do not attempt application if ice, snow, moisture or dew are present. Bonding substrates must be clean, dry and free of dust or other inhibitors of proper adhesion. Ambient temperature must be 50°F or above.
- Store Flintlastic SA rolls indoors on pallets, protected from the elements. Rolls that are improperly stored or have been warehoused for prolonged periods of time may lose their tack.
- Do not apply membrane that has been improperly stored, exposed to moisture, or has lost its tack. If the material isn't bonding, STOP the application!
- Always remember to put safety first and follow all OSHA safety guidelines with any roofing installation.
- Substrates must be free of dust, dirt, oil, debris and moisture.
- Primer, if used, must be applied at the specified rate and must be allowed to thoroughly dry.
- Work with manageable lengths of MidPly and Cap for the particular job. Where appropriate, cut rolls into 1/3- or 1/2-roll lengths and allow material to relax prior to installation.
- In cooler weather, a hand-held hot air welding gun can be used to warm the sidelap areas and improve adhesion (prior to application of the FlintBond SBS Modified Bitumen Adhesive).
- Use caution with the weighted roller at endlap areas. Don't squeeze out too much adhesive.
- When applying MidPly (or PlyBase) directly to substrate, design adequate roof ventilation into the system through the use of roof relief vents.
- Do not mix Flintlastic SA membranes with other types of roof membranes. Flintlastic SA membranes are specifically designed to be applied together. The permanent top film of the MidPly, PlyBase and NailBase cannot receive torching, hot asphalt or other non selfadhering application methods. The Flintlastic SA Cap (or SA Cap FR), PlyBase and MidPly cannot be applied to any surfaces other than as described herein.
- Do not use cold adhesives with Flintlastic SA membranes other than for flashing details and cap sheet overlaps as described herein.
- Refer to the CertainTeed Commercial Roof Systems Manual for complete requirements.
- All plies of the assembly should be installed in one day. If blue film must be exposed for longer periods of time, cover with tarp or suitable alternate protection.



- When applying Flintlastic SA on slopes exceeding 1" in 12", membranes shall be back nailed. When applied parallel to the slope, Flintlastic SA shall be blind-nailed at end laps 2" in from top edge, 6" o.c. through tin discs and to wood nailers. See General Requirements Section of the CertainTeed Commercial Roof Systems Manual for details.

### Deck Preparation

CertainTeed recommends the use of Flintlastic SA NailBase base sheet in conjunction with all self-adhering membrane roof installations. Flintlastic SA NailBase can be mechanically attached to nailable substrates or applied using hot asphalt (non-nailable substrates). For non-nailable substrates where use of hot asphalt to adhere the base sheet may not be appropriate, Flintlastic SA MidPly or Flintlastic SA PlyBase may be used in lieu of Flintlastic SA NailBase on surfaces properly primed with FlintPrime™ SA. However, note that without the use of a base sheet, the membrane may be difficult to later remove (if necessary) and certain UL and FM listings for the products may not apply. Prior to application of Flintlastic SA products, ensure roofs have positive drainage. Consult the local building official for minimum slope and drainage requirements.

### Application of Flintlastic SA NailBase

Beginning at the low point of the roof, mechanically fasten Flintlastic SA NailBase to nailable deck using appropriate fasteners. Start with an appropriate roll width (1/3 or 1/2 roll) to accommodate offsetting of sidelaps of subsequent layers of MidPly and/or Cap sheet. Install so that no sidelaps are against the flow of water. A minimum fastening pattern is every 9" on center on sidelaps and every 18" on center in two staggered rows in the field of the sheet.

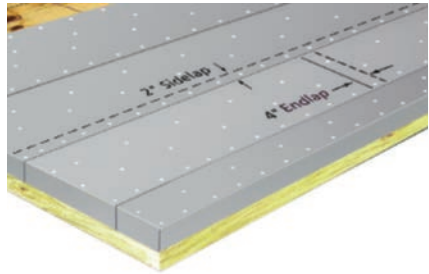

Prime non-nailable substrates such as concrete using FlintPrime SA polymer-based primer. Allow to dry thoroughly, but not more than 4 hours to retain tack-enhancing properties. Apply SA NailBase using ASTM Type III or IV hot asphalt\* at the rate of 25 lbs. per 100ft<sup>2</sup> (Spot mopping – 15 lbs. per 100ft<sup>2</sup>) or self-adhere SA PlyBase (or MidPly).



Overlap base sheet sidelaps 2" and endlaps 4". Offset endlaps a minimum of 3'. Turn base sheet over fascia. Do not leave installed base exposed. Cover in the same day with Flintlastic SA MidPly and/or Flintlastic SA Cap (or SA Cap FR).

Don't leave the installed Flintlastic SA NailBase exposed to the weather; cover with Flintlastic SA Cap the same day.

### **Application of Flintlastic SA Mid Ply or PlyBase to insulate decks**

SA MidPly or PlyBase may be adhered directly to mechanically fastened FlintBoard ISO or adhered to FlintBoard ISO Cold.

Before installing, sweep the surface of the insulation boards to remove any dust, dirt or sand particles that could interfere with adhesion.

Start application at the low point of the roof. Install flush to roof edge. Design layout so that no sidelaps are against the flow of water.

### **Application of Interply**

Note: Proceed to "Before Installing Flintlastic SA Cap (or SA Cap FR)" if installing a 2-ply system.

Before installing Flintlastic SA MidPly (or PlyBase), sweep the underlying base sheet or primed surface to remove any dust, dirt or sand particles that could interfere with adhesion.

Apply MidPly (or PlyBase) over installed Flintlastic SA NailBase or, for non-nailable decks such as concrete, properly primed substrates. Surface must be dry and free from dust or dirt.

Start MidPly (or PlyBase) application at the low point of the roof with appropriate roll width to offset sidelaps 18" from sidelaps of base sheet. Install flush to roof edge if over base sheet, otherwise turn the MidPly (or PlyBase) over the fascia minimum 2" and secure. Design layout so that no sidelaps are against the flow of water.

Cut rolls into manageable lengths. Fold the membrane back halfway lengthwise to remove the split release film. Press membrane securely into place, and repeat with the opposite half of the membrane. Use a heavy, weighted roller over the entire surface of the Flintlastic SA MidPly (or PlyBase) membrane to secure the membrane. Work outwards to eliminate voids.

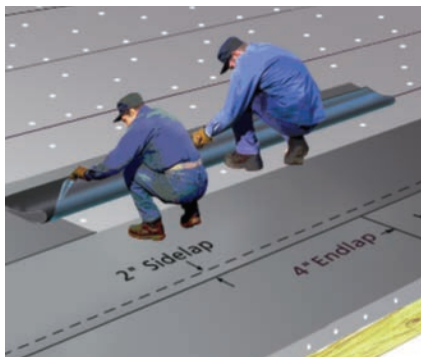

Overlap sidelaps of subsequent MidPly (or PlyBase) membrane lengths 2" and endlaps 6". Offset (stagger) endlaps minimum 3'. Cut endlaps at opposing diagonal corners at an angle approximately 5-1/2" long by the selvage dimension from the corners to minimize "T"-seams. Apply a bead or small trowel dab (quarter size) of FlintBond™ SBS Modified Bitumen Adhesive, trowel or caulk grade, at the edge of the angled cut to avoid a capillary. Use of a hand-held hot air gun at the joint area prior to rolling the membrane will maximize adhesion. In areas prone to cold temperatures, snow and freeze-thaw cycles, it may be more effective to use the hot air gun to form joints, and to completely fill all mole holes with asphalt that has been slightly melted using the gun. It is recommended to apply a bead of FlintBond SBS Modified Bitumen Adhesive, caulk grade, at all MidPly (or PlyBase) side and endlaps to eliminate a capillary.

Don't leave the installed Flintlastic SA MidPly (or PlyBase) exposed to the weather; cover with Flintlastic SA Cap the same day.

### **Before Installing Flintlastic SA Cap (or SA Cap FR)**

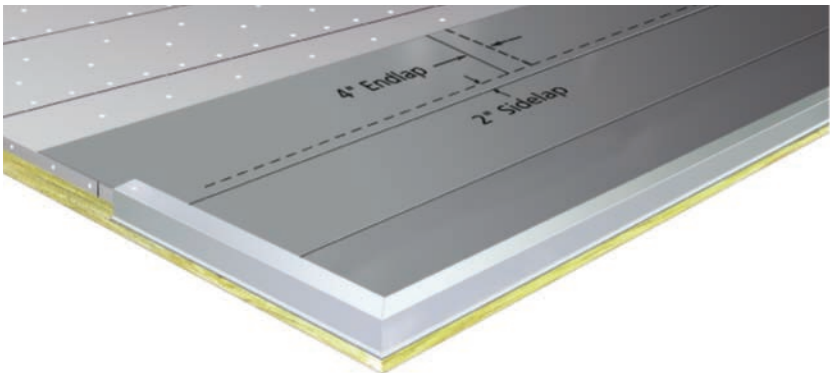

If roof edge detail utilizes edge metal, proceed as follows. If MidPly has been applied, install minimum 26 gauge edge metal using appropriate fasteners, and set entirely in a uniform 1/8"-1/4" thick troweling of FlintBond SBS Modified Bitumen Adhesive, trowel grade. Remove any oil from the metal surface using a vinegar and water solution. Prime the horizontal surface of the metal with FlintPrime SA and allow primer to dry. Apply a bead of caulk grade FlintBond adhesive to the edge of the metal where it meets the MidPly. Proceed with Flintlastic SA Cap (or SA Cap FR) installation.

If MidPly is not specified: Over the Flintlastic SA NailBase, install a 9" wide strip of MidPly onto the field of the roof and flush to the roof edge, self-adhered. Install minimum 26 gauge edge metal using appropriate fasteners, set entirely in a uniform 1/8"-1/4" thick troweling of FlintBond SBS

Modified Bitumen Adhesive, trowel grade. Remove any oil from the metal surface using a vinegar and water solution. Prime the horizontal surface of the metal with FlintPrime or FlintPrime SA and allow primer to dry. Apply a bead of caulk grade FlintBond SBS Modified Bitumen Adhesive at the roof side edge of the metal where it meets the MidPly strip. Proceed with cap sheet installation.

Similarly, complete your sheet metal flashing installation using cut MidPly flashing collars at all flashing details prior to flashing application. Seal edges of MidPly flashing collars with a bead of FlintBond. See “Typical Construction Details,” starting on page 45 for examples. If MidPly has been installed as part of the system, set flanges in trowel grade FlintBond and properly fasten. All cap sheet flashings installed to transitions that overlap onto mineral surface must be set in a uniform troweling of FlintBond trowel grade adhesive.

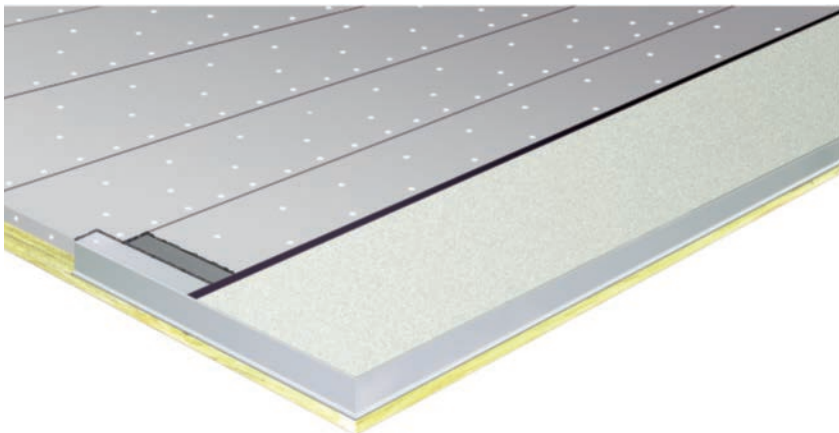

### **Application of Flintlastic SA Cap (or SA Cap FR)**

Before installing Flintlastic SA Cap (or SA Cap FR), sweep the surface of the installed SA NailBase (or PlyBase) or MidPly clean. To install Flintlastic SA Cap (or SA Cap FR), start at the low point of the roof with an appropriate roll width to offset sidelaps from the underlying membrane a minimum of 18". Work with manageable lengths for proper handling.

Position SA Cap (or SA Cap FR) with selvage edge release strip at high side of roof. Install in weather-lapped fashion, with no laps against the flow of water.



Once positioned, lift and fold back (lengthwise) the lower half of the membrane. Remove the split release film and press firmly into place. Then repeat with the other (high side of the roof) half of the membrane.

Follow the same layout and split release film procedures as for MidPly (or PlyBase), but overlap sidelaps 3" and endlaps 6". Use a weighted roller over the entire surface of Flintlastic SA Cap (or SA Cap FR) to secure it in place and prevent voids, working outward from the center of the sheet.

As subsequent membrane lengths are installed, remove the selvage edge release strip just prior to overlapping to keep the adhesive area protected and clean. Cut endlaps at opposing diagonal corners at an angle approx. 3" by 5-1/2" from the corners to minimize T-seams.

Use FlintBond SBS Modified Bitumen Adhesive, trowel grade, on the entire 6" width of each endlap prior to overlapping. Apply a uniform 1/8"-1/4" troweling of the FlintBond on the entire width of the endlaps to the underlying membrane. Install the overlapping sheet. Always apply FlintBond (extend beyond underlying lap minimum 1/4") on the entire width of any overlap when applying SA Cap (or SA Cap FR) over another mineral surface such as the SA Cap (or SA Cap FR) endlap.

At all vertical and other flashing points, apply FlintBond SBS Modified Bitumen Adhesive, trowel grade, wherever there is an overlap onto mineral surfacing.

Once the membrane has had a chance to bond, check all laps and joints for full adhesion. If the membrane can be lifted at any area it is not properly adhered. A seam probing tool can be helpful to check for small voids at laps.

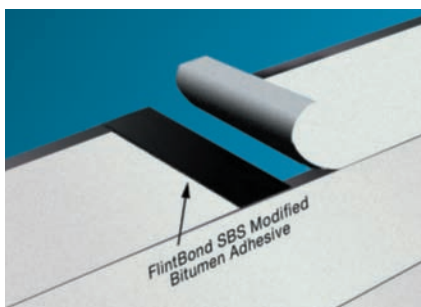

If necessary, use appropriate hand-held hot air welding tool and seam roller or an application of FlintBond to seal small unbonded areas if they exist.

Included in this manual are a few common construction details. Please refer to CertainTeed's standard details or the NRCA for details not found within this manual. Important to note with all details, all metal must be primed and set in FlintBond Trowel Grade adhesive and all overlaps over mineral surfacing must utilize FlintBond Trowel Grade adhesive.

### The Proper T-Seam Detail

- Before adhering Flintlastic SA MidPly or Cap (or SA Cap FR) endlaps, trim the underlying sheet's lower corner at the end of the roll.
- Follow with the overlapping sheet, trimming the upper outside corner.
- Corners should be trimmed on a diagonal angle 5½" long from end of roll to outside edge.
- Width of trim should be equal in width to the sidelap specified (3" for Flintlastic SA Cap [or SA Cap FR] and 2" for Flintlastic SA MidPly [or PlyBase]).
- Trimmed corners should be completely covered by application of succeeding courses.
- Note: If using Flintlastic SA MidPly (or PlyBase), apply quarter-size dab of FlintBond at T-seam area. If using Flintlastic SA Cap (or SA Cap FR), the endlap should be completely set in trowel grade FlintBond along the entire 6" lap width.

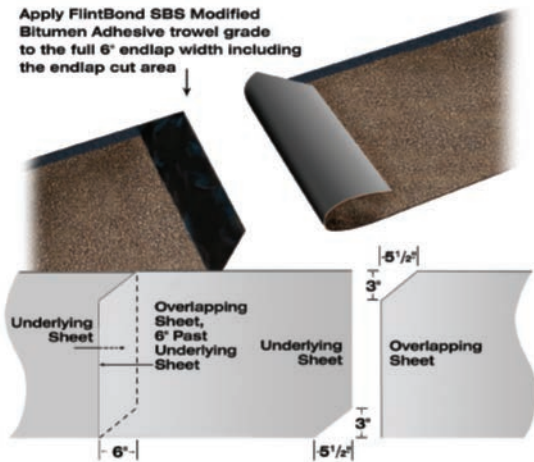

### Rake Edge Detail

- Cut selvage area at an angle at all rake edges.
- Apply a bead of FlintBond caulk along cut edge to eliminate mole holes.

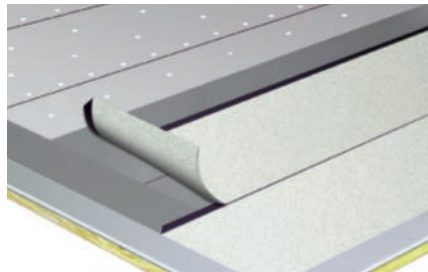

# Typical Construction Details - Flintlastic SA 2-Ply System

## Shingle Transition

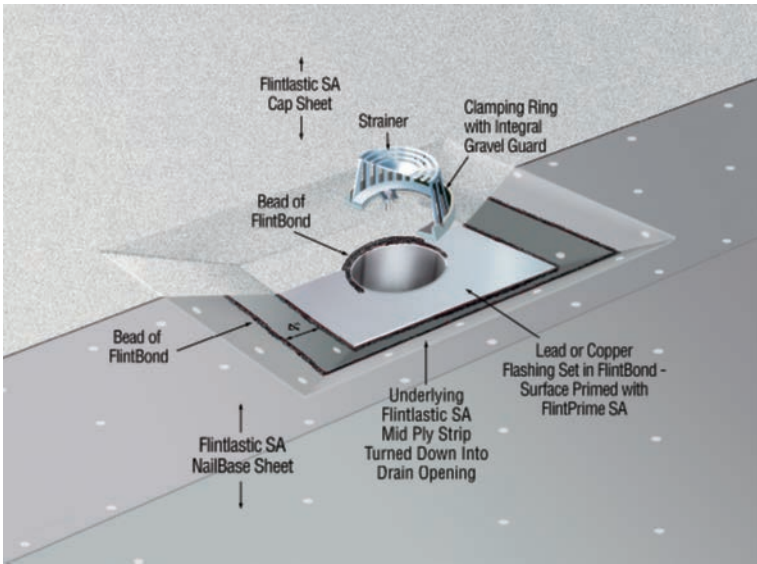
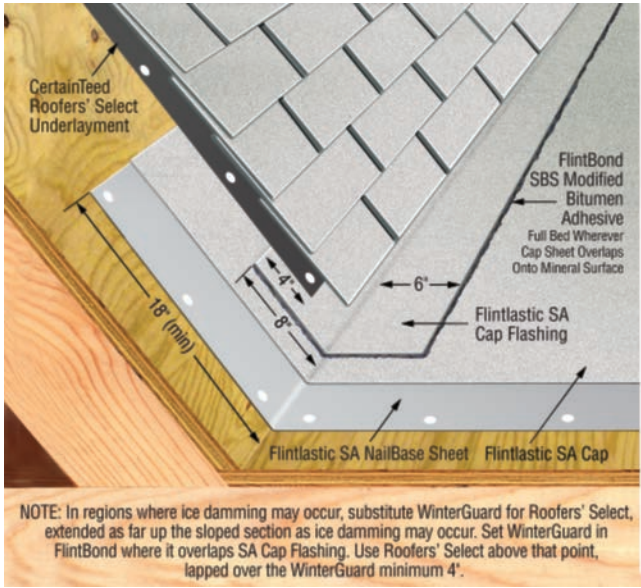

## Drain Detail

# Typical Construction Details – Flintlastic SA 2-Ply System

## Wood Parapet Wall Detail

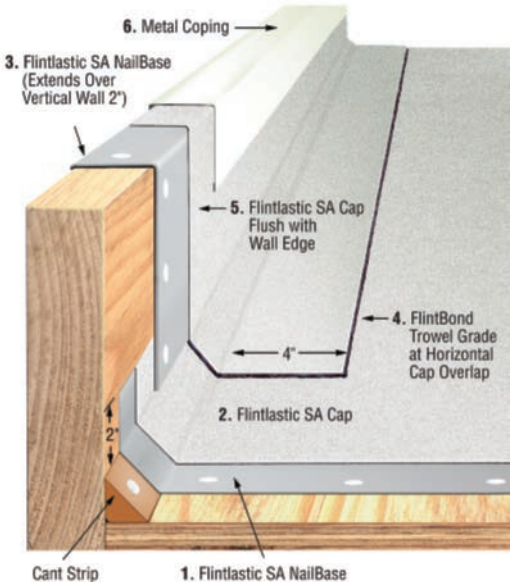



# Typical Construction Details – Flintlastic SA 2-Ply System

## Scupper Detail

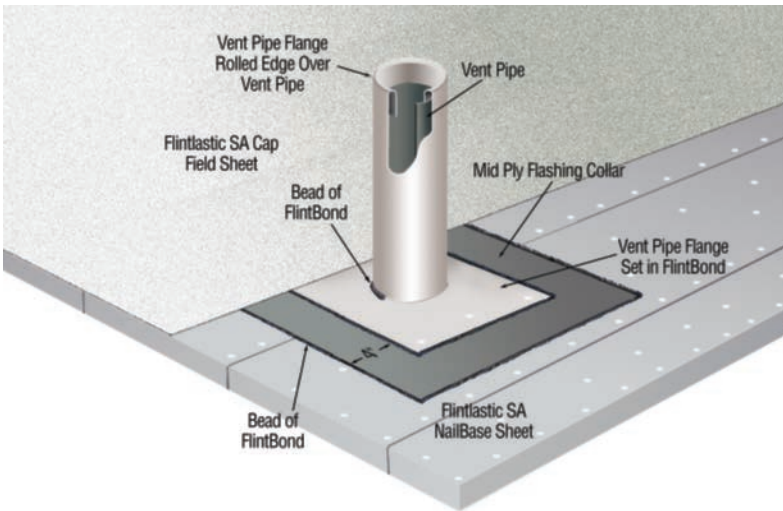
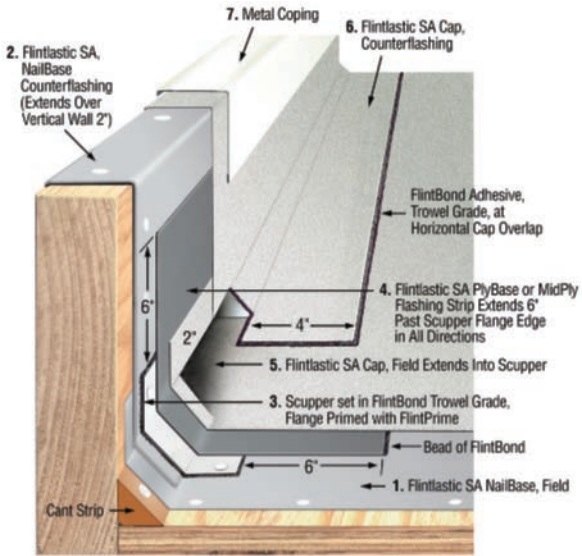

## Vent Pipe Collar Detail

# Typical Construction Details – Flintlastic SA 2-Ply System

## Edge Detail With Insulation

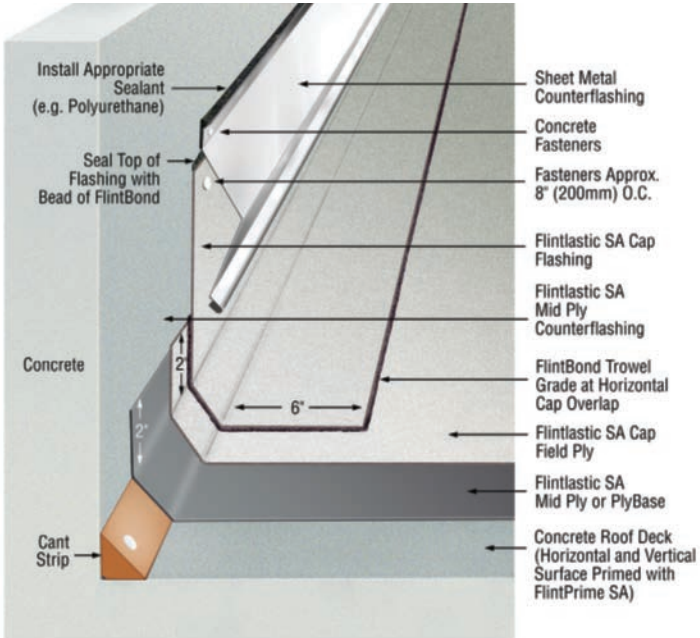
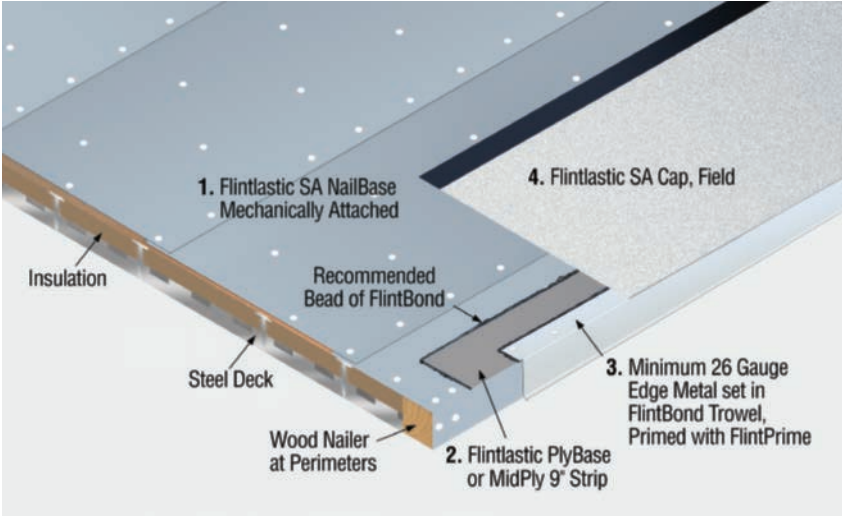

## Concrete Wall Termination with Surface Mount Flashing

# Typical Construction Details – Flintlastic SA 2-Ply System

## Inside Corner

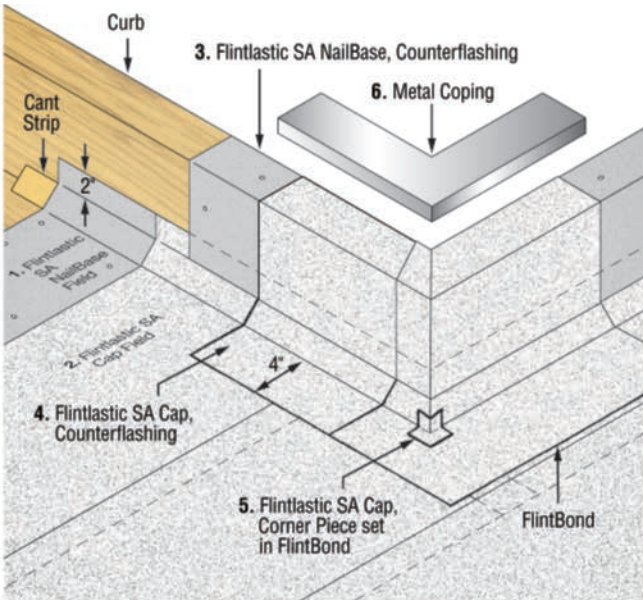
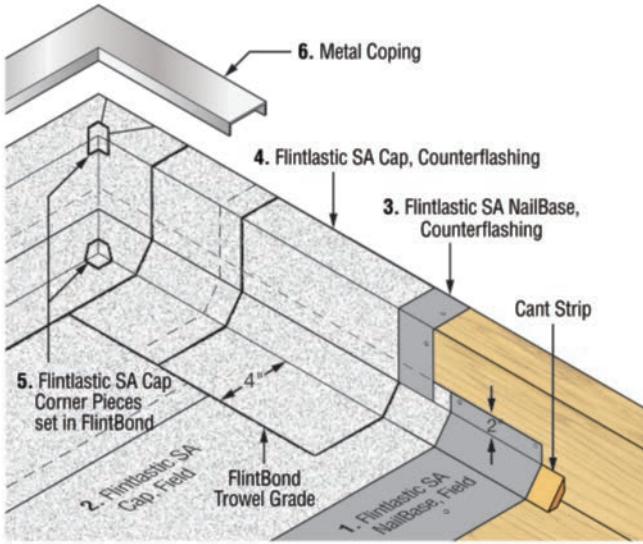

## Outside Corner

# Typical Construction Details – Flintlastic SA 3-Ply System

## Shingle Transition

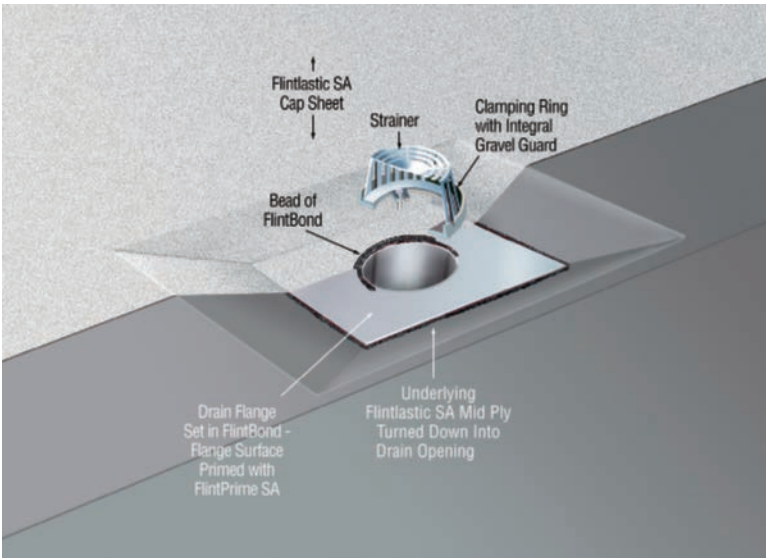
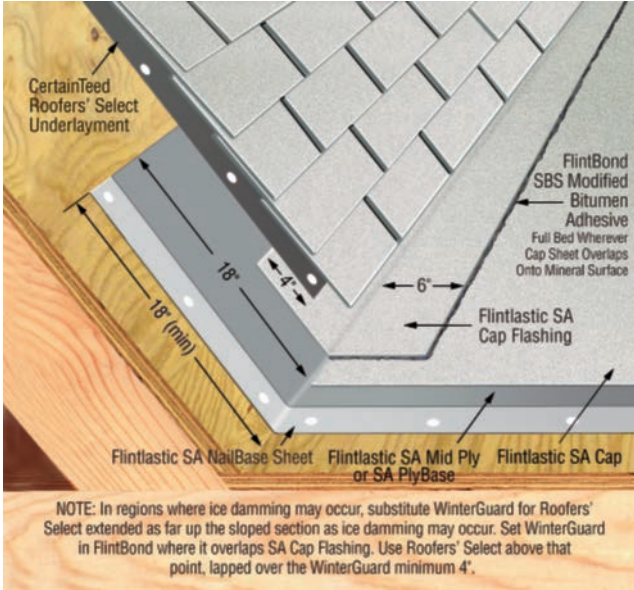

## Drain Detail

# Typical Construction Details – Flintlastic SA 3-Ply System

## Vent Pipe Collar Detail

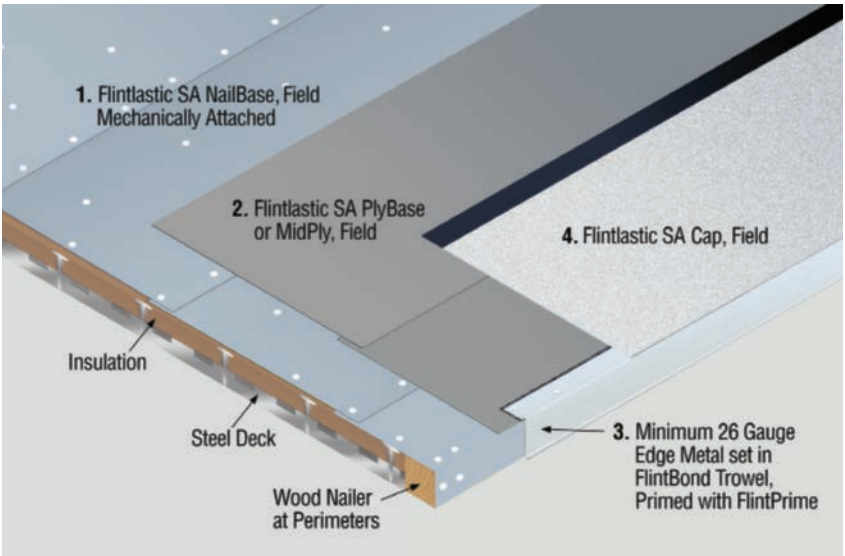
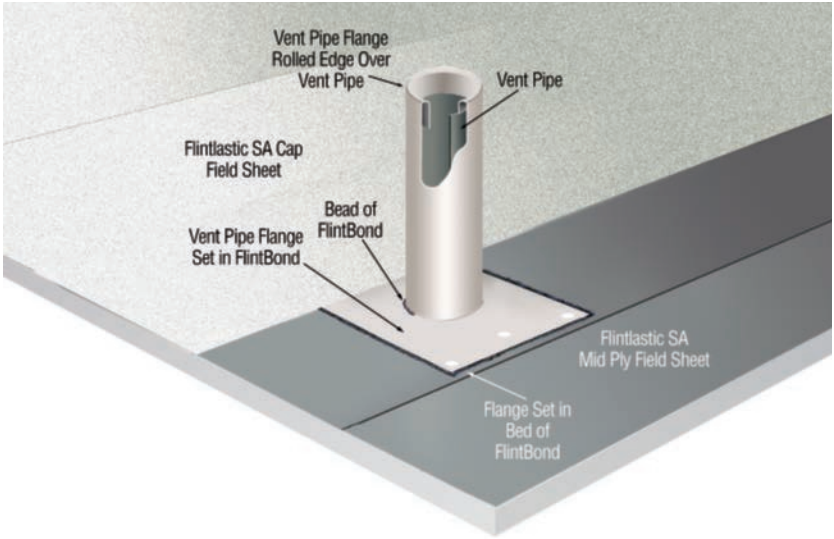

## Edge Detail

## Job Completion

Before considering any roof project complete, walk the roof and check laps for any signs of unbonded areas (a trowel can be used for this purpose). Check flashing details to be sure they are secure. Leave roof and premises clean and free of any roofing debris (daily). Be sure all vent caps are snug and drain screens securely in place.

## Safety Tips

As stated in the warning on page 18, use of propane torches and hot asphalt requires thorough knowledge and skill in all aspects of safety with respect to their use and handling. CertainTeed recommends that professional applicators receive the CERTA torch safety training as offered by the MRCA or NRCA (see inside cover) and participate in all asphalt heating and handling safety training available through their local roofing associations, ARMA and NFPA (see inside cover), local fire departments, OSHA and the NRCA, among others.

**Under no circumstances should Flintlastic modified bitumen roofing application be attempted by “do-it-yourselfers” or any persons other than professional, trained roofers. It is the roofing contractor’s sole responsibility to be certain all crew members are appropriately trained in safe and proper use of propane torching and hot asphalt equipment and procedures.**

**The following safety tips are a general reference only and are in no way all-inclusive.**

### Job Watch

When the torch application method is used, it is important to remember that carelessness resulting in heat entering a crevice may cause concealed smoldering. A supervisor trained in fire safety should remain on the jobsite a minimum of 4 hours after cessation of torching to check for any signs of smoke, smoldering or fire. The safety check should utilize infra-red thermometers and should include a thorough interior check of the attic, crawl spaces and return air ducts in addition to the roof area where torches have been utilized. Prior to leaving the jobsite the contractor must be certain that all chance of fire, including smoldering fire, has been eliminated.

### Personnel

- Proper clothing, including work boots, long pants, long sleeved shirts and gloves, must be worn. It is the contractor’s responsibility to require employees to wear proper attire.
- Workmen, other than the torch operator, should be not closer than 3 feet to the torch flame.

- It is the contractor's responsibility to observe all fire prevention policies and practices during the installation of the roof system.
- It is the contractor's responsibility to train, instruct and warn employees on the use and handling of propane torching equipment.
- Extra caution must be used when torching near exposed edges of insulation to prevent flame from coming into contact with any flammable material. Contact for any length of time with lead or other materials affected by heat must be avoided.
- Never use the equipment in an enclosed area.
- Refer to NFPA S8 "Standard for the Storage and Handling of Liquefied Petroleum Gas" and appropriate publications of the National Propane Gas Association (1150 17th St. NW, Ste. 310, Washington, DC 20036-4623 Ph. 202-466-7200) and the National Fire Protection Association (1 Batterymarch Park, Quincy, MA 02169-7471 Ph. 617-770-3000).

### **Fire Department Regulations**

- Written notice should be given to the local fire department and any necessary permits must be acquired.
- The required number of fire extinguishers shall be on the roof at all times.
- Portable smoke detectors should be installed in attics as required by the local fire department.
- All supervisors and crew members on the jobsite shall have fire safety training. The crew supervisor or foreman must remain on the jobsite **at least 4 hours** after cessation of torching, and shall check the complete roof and attic area for any signs of smoke or smoldering.
- No flammable liquids shall be stored or used on the roof (excluding LPG in approved containers). Any LPG not in use shall be stored on the ground.

### **Tools and Equipment**

- Be certain that all torching equipment is in good working order.
- Be certain cylinder valves are clean.
- Use an adjustable pilot with a complete shut-off valve.
- Use a flint or electronic ignitor to light the torch. Matches or disposable lighters are unsafe and not acceptable.
- Do not use any equipment without an operating pressure gauge.
- Do not operate any pressure gauge beyond the top of its scale, near excessive heat (above 150°F) or where there is excessive vibration.
- Use a torch stand to direct the torch flame upward when the torch is briefly set down. Shut off completely when not in use.

- Propane tanks must be secured in an upright position, placed a minimum of 10' from the torch flame at all times.
- Secure propane tanks when on the roof.
- Increase the size of the propane tank if necessary to prevent frost from occurring. Never heat the tank with a torch or any other device, and never put the torch flame anywhere near the tank.
- Never turn a propane tank on its side to increase pressure. Liquid could escape.
- Protect cylinder valves, and where possible use cylinders that have valve protection welded to the cylinder. **Never lift a cylinder by the valve. Valves are made of soft brass and are easily broken.**
- Do not tighten brass fittings too tightly with a wrench.
- Do not attempt to put out a cylinder fire if it cannot be done without tipping the tank; Call the fire department.
- Never fill a propane cylinder that is in need of repair.
- Never lay a torch to rest on a gas cylinder.
- Use only hose intended for use with LP gas.
- Do not use hose longer than 50'.
- Use an adjustable, U.L. listed regulator with the torch.
- Keep vent in pressure regulator unobstructed at all times.
- Make sure flow of gas through regulator is in the proper direction. Directional flow is indicated on the regulator.
- Use a soap solution to check for gas leaks before lighting torch. Then check for proper operation of the torch. **Never check for leaks using lighter or matches.**
- If a leak occurs, stop work immediately and repair all relevant parts. Do not use any torch equipment that is leaking gas at any fitting.
- Stop torching immediately if any propane odor is detected.
- Check hoses frequently for wear and tear, and do not allow torch flame to come into contact with them. Keep hoses free of kinks and do not allow heavy equipment to roll over them. Also check hoses for any signs of burned or charred areas.
- Be aware of the difference between liquid and vapor gas bottles and dispensing equipment.



- Treat the torch as if it is always burning. In sunlight it can be difficult to see the flame, and when working near mechanical equipment you cannot always hear the torch.
- Never leave a torch unattended.
- Never lay a torch over the edge of the roof.
- Do not use a trowel as a torch stand.
- When shutting off the torch, close the propane cylinder valve first and let the remaining gas burn out of the hose before closing the torch valve.
- Keep an ABC or Halon fire extinguisher on the roof, readily accessible to each worker using a torch at all times. Make sure the extinguisher is readily accessible, but not so close to the torch or propane equipment that it cannot be safely accessed in the event of a fire.
- When using a dry chemical type extinguisher, direct the chemical stream at the base of the fire from a safe distance of about 10' to 15'. Sweep the fire away from you, starting at its nearest point and moving the chemical stream toward the furthest point.
- Do not use soda acid fire extinguisher—it spreads the flame.
- Check all equipment for wear and tear and repair or replace as necessary.
- Use extreme caution when working with torches in areas where you cannot see. Heat the membrane away from the area and then apply it to the flashing. Do not torch directly into any crevice or unsafe area where flame could be sucked in.
- Protect all equipment from damage; store in a toolbox.

### **Building Safety**

- Use noncombustible type cant strips such as perlite or fiber glass and cover them with appropriate CertainTeed base sheet.
- Use appropriate CertainTeed base sheet over all nailable deck types including plywood, wood, lightweight insulating concrete, and over all insulations and any flammable surface.
- Use noncombustible insulation, and cover it with appropriate CertainTeed base sheet (see also page 12).
- Install metal flashings to penetrations or protect flashings with tight-fitting collar prior to torching.
- Use a small detail torch when applying flashing details.
- Be certain all air conditioning units, exhaust fans, and air intake fans in the work area are shut off at the roof control.

- Shield air conditioning units and other protrusions with perlite or similar panels when using the torch around them. Heat roofing membrane away from air conditioning units, fans, soil pipes, and all other protrusions, and set in place while still hot. Use extreme caution to prevent the flame from being pulled into the building interior.
- Feather seams around details with a warm trowel.
- When torching at flashings, corners or voids in the roof or roof deck, never torch directly. Always torch the membrane to be applied and then adhere it to the corner or joint.
- Use caution when torching near pipes in the event there is suction present. Failure to utilize base sheet as required by manufacturer specifications is extremely dangerous as the base sheet provides a protective covering for underlying combustibles.
- Examine the roof substrate for any void, hole or gap and fill it with noncombustible or perlite cant strip. Cover the cant strip with CertainTeed Type G2 fiber glass base sheet.
- Never torch directly to insulation. Appropriate CertainTeed base sheet is required over all insulations. RIC/TIMA recommends that polyurethane and polyisocyanurate insulations be isolated from the roof membrane via the use of an additional layer of noncombustible insulation and CertainTeed base sheet, or an interim base ply acceptable to the membrane manufacturer.
- Install CertainTeed Type G2 fiber glass base sheet over all flammable surfaces and insulations. Base sheet must fit tightly around all deck openings and must turn up parapet walls so that torch flame cannot flash down into and start a fire underneath the deck.
- Never torch into any area where you cannot see; do not use the torch in areas such as under air conditioning units or behind counterflashing.
- Don't torch directly to wood fiber cant strips or wood fiber insulations.
- Don't torch directly to any cant strip, insulation, wood or any other flammable surface.
- Never torch near gas lines or electrical wires.
- Never torch to flammable surfaces such as EPS insulations.
- Never torch around flammable vents.
- Do not point the torch under rooftop equipment.
- Do not direct the torch down open roof penetrations, or near openings around roof penetrations.

- Never point the torch at low flashings where there is an overhang and flame could get up under the counterflashing (such as around skylights or prefabricated curbs with fiberboard sidewall insulation).
- Torching equipment is made for roofing application only and should not be used for drying out a roof or as a preheater torch.
- **Never** apply modified bitumen products directly over exposed conduits or pipes laying on the roof deck.
- LP gas is heavier than air. Do not work in an enclosed area where gas can accumulate.
- Do not rest an operating torch directly on the membrane. There is danger of fire and danger of damaging the membrane.
- Don't lay an operating torch on an open penetration on the roof. If the penetration is part of an air intake system, the flame could be sucked into the building.

### **Additional Hot Asphalt Considerations**

- **Maintain** kettle and tanker temperatures less than 25°F below the actual flash point of the material used.
- **NEVER** heat materials to or above the actual flash point.
- **Don't** maintain asphalt at high temperatures for prolonged periods of time.
- **Don't** allow asphalt to stand in luggers for long periods of times.
- **Use** insulated hot bitumen transport lines to help maintain acceptable bitumen temperature at point of application.
- **Circulate** bitumen while heating.

# Reference Table - General Guide to Mechanical Fasteners

FASTENER USE	DECK TYPE													
	INSULATION	RAE BERT	WOOD BALKS	P/ALU./TRIM BALK	STEEL DECK	PL WOOD DECK	NOVENNERS DECK	WOOD PLANK DECK	POURED CONC DECK	PRECAST CONC	CHEMICAL CONC	CONCRETE/WOOD PANEL	LT. WT. METAL PANEL	POURED SYSTEM
INSULATION	•													
RAE BERT	•													
WOOD BALKS	•													
P/ALU./TRIM BALK														
STEEL DECK	•													
PL WOOD DECK	•													
NOVENNERS DECK	•													
WOOD PLANK DECK	•													
POURED CONC DECK														
PRECAST CONC														
CHEMICAL CONC														
CONCRETE/WOOD PANEL														
LT. WT. METAL PANEL														
POURED SYSTEM														

1	<p>STANDARD (ROUND HEAD) ROOFING NAILS</p>
2	<p>LARGE HEAD ROOFING NAILS</p>
3	<p>PNEUMATICALLY DRIVEN STAPLE AND TAPE OR CAP</p>
4	<p>BASE SHEET FASTENERS FOR SOME CEMENTITIOUS ROOF DECKS</p>
5	<p>SELF-LOCKING FASTENERS</p>

# Reference Table - General Guide to Mechanical Fasteners

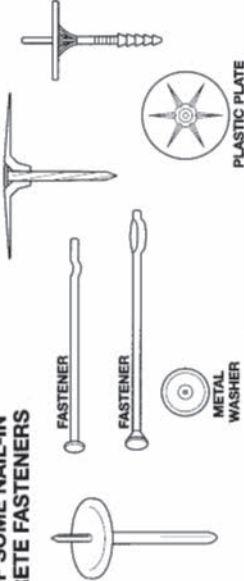
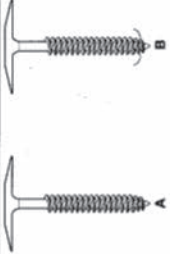

FASTENER TYPE	FASTENER USE		DECK TYPE											
	INSULATION	WOOD SHEET	WOOD NAILER	FLASH/TERR BAR	STEEL DECK	PLYWOOD DECK	MEMBER DECK	WOOD PLANK DECK	POURED CONC. DECK	PRESTRESS CONC.	PRECAST CONC.	CEMENT/WOOD FIBER	LT WT. INSUL. CONC.	POURED GYPSUM
6	 <p>BARBED CLIP FASTENER METAL PLATE</p>				•									
7	 <p>EXAMPLES OF SOME NAIL-IN TYPE CONCRETE FASTENERS FASTENER FASTENER METAL WASHER PLASTIC PLATE</p>		•				•	•	•					
8	 <p>PLASTIC THREADED FASTENER A B</p>		•										•	•

Reference Table - General Guide to Mechanical Fasteners

FASTENER TYPE	FASTENER USE	DECK TYPE													
		RESILANT	WOOD WALKER	FLAME TREAT MBI	SPRUC DECK	ALUMINUM DECK	ALUMINUM DECK	WOOD PLANK DECK	WOOD PLANK DECK	PERFORATED CONC. DECK	PERFORATED CONC. DECK	SMOOTH CONC.	GRAVEL/TIMBER FIBER	LEAF METAL CONC.	POURED ASPHALT
9	<p><b>TOGGLE BOLT</b></p> <p>STEEL PLATE PLASTIC PLATE TOGGLE BOLTS PLATE TOGGLE</p>	•	•	•	•	•	•	•	•	•	•	•	•	•	•
10	<p><b>TWO-PIECE TUBE NAIL</b></p> <p>NAIL INSERT NAIL LOCKED IN DECK</p>	•													
11	<p><b>EXPANSION FASTENER (LEAD OR NYLON)</b></p> <p>ONE PIECE TUBE/ ATTACHED DISC</p>	•	•												

# Reference Table - General Guide to Mechanical Fasteners

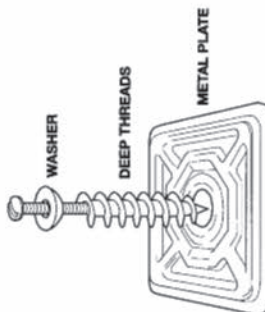
FASTENER USE	DECK TYPE		
		●	●
INSULATION		●	●
BASE SHEET		●	●
WOOD NAILS		●	●
FLASH/TRIM BAY		●	●
STEEL DECK		●	●
PLYWOOD DECK		●	●
ALUMINUM DECK		●	●
WOOD PLANK DECK		●	●
POURED CONG. DECK			
PRESTRESSED CONG.			
PRECAST CONG.		●	
CONCRETE/WOOD FIBER			
LIQHT. INFL. CONG.		●	
POURED GYPSUM			

12	<p><b>FASTENER TYPE</b></p> <p><b>MULTI-PIECE SCREW FASTENER</b></p>  <p>WASHER DEEP THREADS METAL PLATE</p>
13	<p><b>FASTENER TYPE</b></p> <p><b>THREADED SELF-DRILLING INSULATION FASTENERS (SCREWS &amp; PLATES)</b></p>  <p>PLATE SCREW</p>

## Flintlastic Application Specialist Questions

1. Model building codes and good roofing practice have established a minimum slope to ensure good roof drainage. What is the minimum?
  - a.  $1/8'' : 12''$
  - b.  $1/4'' : 12''$
  - c.  $1/2'' : 12''$
  - d. Positive drainage
  
2. Which of the following surfaces must be primed before adhering insulation or asphaltic membranes?
  - a. Concrete
  - b. Metal Flashings
  - c. Masonry
  - d. All of the above
  
3. To reduce thermal stress to roofing membranes, CertainTeed recommends the use of multiple layers of insulation. Joints between layers should be staggered a minimum of \_\_\_\_\_.
  - a. 3"
  - b. 6"
  - c. 9"
  - d. 12"
  
4. When spot-mopping a base sheet to a non-nailable surface, apply \_\_\_\_\_ diameter circles \_\_\_\_\_ o.c. in all directions. This will give you the minimum rate of 15 lbs. per square of asphalt.
  - a. 9", 24"
  - b. 12", 18"
  - c. 12", 24"
  - d. 18", 9"
  
5. In low-slope roofing, membranes are typically applied perpendicular to the slope. However, steeper slopes require parallel (or strapping) installation. SBS-modified and self-adhering(SA) membranes must be installed parallel when the roof slope exceeds  $1'' : 12''$ . APP-modified membranes must be strapped when the slope exceeds  $2'' : 12''$ .
  - a. True
  - b. False



6. Membrane endlaps must be staggered a minimum of \_\_\_\_.
- a. 6"
  - b. 12"
  - c. 2'
  - d. 3'
7. Base flashing or parapet wall flashing: field membranes must extend at least \_\_\_\_ above the top of the cant strip. Base flashing must extend a minimum of \_\_\_\_ onto the field membrane.
- a. 4", 4"
  - b. 2", 4"
  - c. 2", 2"
  - d. 4", 8"
8. Application rate for solid mopping is \_\_\_\_ / 100 square feet.  
The application rate for spot mopping is \_\_\_\_ / 100 square feet.
- a. 25 lbs; 15 lbs
  - b. 25 lbs; 10 lbs
  - c. 30 lbs; 15 lbs
  - d. 20 lbs; 10 lbs
9. When the torch application method is used, it is important that a trained supervisor remain on the jobsite at least \_\_\_\_ after cessation of torching to ensure there are no signs of smoke or smoldering in the completed roof system or attic area.
- a. 30 minutes
  - b. 2 hours
  - c. 4 hours
  - d. 8 hours
10. Torch safety: The following should be used to check for gas leaks in the propane tank prior to lighting the torch:
- a. Lighter
  - b. Matches
  - c. Soap solution
  - d. Water

11. It is safe to torch directly to insulation boards.
- a. True
  - b. False
12. The following precautions will help maintain hot asphalt integrity in a kettle or tanker:
- a. Use insulated hot bitumen transport lines
  - b. Circulate bitumen while heating
  - c. Both a and b are correct
  - d. None of the above
13. The following tools are needed to successfully install a Flintlastic SA, self-adhering roofing system:
- a. Weighted roller
  - b. Caulk gun and trowel for adhesive
  - c. Hand-held hot air welding gun
  - d. All of the above
14. Rolls should be stored laying on their sides, not standing upright.
- a. True
  - b. False
15. Torch using an \_\_\_\_\_ pattern
- a. "S"
  - b. "L"
  - c. "V"
  - d. "O"
16. Most building codes limit recovers to \_\_\_\_\_ additional roof(s).
- a. Zero
  - b. One
  - c. Two
  - d. Three

17. The existing roof should be evaluated for moisture and for adhesion to the underlying substrate. All wet roofing material must be removed prior to recover.
- a. True
  - b. False
18. In order for a recover system to qualify for a CertainTeed warranty, a list of criteria must be met. There are \_\_\_\_\_ requirements.
- a. 12
  - b. 20
  - c. 22
  - d. 30
19. When roofing over an existing system, be sure to fully adhere the base layer of the new system.
- a. True
  - b. False
20. Base insulation over a steel deck must be mechanically fastened through the steel. The screws must penetrate a minimum of \_\_\_\_\_.
- a. 1/2"
  - b. 3/4"
  - c. 1"
  - d. 1-1/2"
21. In a warranted re-roof or overlay situation, the following is true or false regarding existing ring clamp drains should be stripped to bare metal, damaged drain components replaced, clamping rings saved for re-use, old bolts replaced with new and a minimum 30" X 30" 4lbs. sheet lead flashing installed.
- a. True
  - b. False
22. When applying insulation over a steel deck, the fasteners must penetrate through:
- a. The rib
  - b. The flange
  - c. The flute
  - d. Any part of the deck

23. What is the proper flashing sealant for APP modified bitumen roofing systems?
- Melted bitumen
  - FlintBond Trowel Grade
  - Any good quality flashing compound
  - Any good quality modified plastic cement
24. When applying Flintlastic SA self-adhered roofing systems, which of the following are considered to be release agents?
- Dirt and fines
  - Moisture
  - Pollen and dust
  - All of the above
25. CertainTeed offers APP, SBS and SBS self-adhered modified systems, with some minor variation; the published flashing details for each system are essentially the same.
- True
  - False
26. Hot asphalt applied Flintlastic SBS membranes must be installed with bitumen at the following temperature: EVT +/- 25°F, minimum 425°F.
- True
  - False
27. Which of the following in cold process application of SBS and built up roof systems is not used?
- Base sheets and cap sheets
  - Type 4 or type 6 ply sheets
  - Brush, spray or roll application
  - Calendaring with a notched squeegee
28. For cold adhesive application, use the mop and flop method and back mop all side and end laps.
- True
  - False





Caution: CertainTeed Flintlastic roofing products are intended for use by professional roofing contractors only. It is the responsibility of the installer to follow all appropriate and required safety precautions in conjunction with the installation of any CertainTeed roofing product.

**ASK ABOUT ALL OF OUR OTHER CERTAINTEED® PRODUCTS AND SYSTEMS:**

ROOFING • SIDING • TRIM • DECKING • RAILING • FENCE  
GYPSUM • CEILINGS • INSULATION

[www.certainteed.com](http://www.certainteed.com)    <http://blog.certainteed.com>

CertainTeed Corporation  
20 Moores Road  
Malvern, PA 19355

Professional: 800-233-8990  
Consumer: 800-782-8777

© 04/16 CertainTeed Corporation, Printed in U.S.A.  
Code No. COMM-243

