

Attic Ventilation

Ridge Vents and Intake Vents

 certainteed
SAINT-GOBAIN

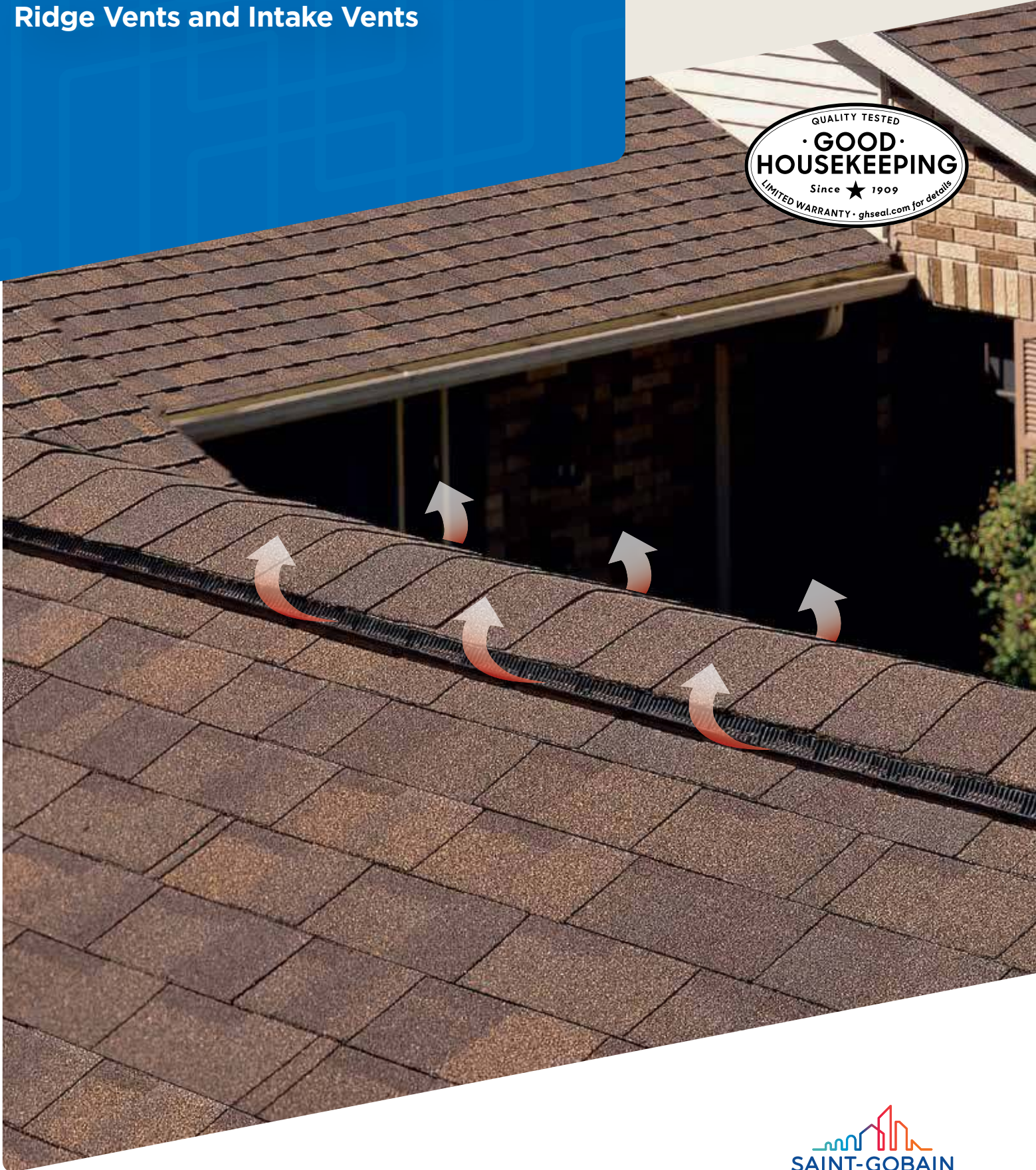

SAINT-GOBAIN

Attic Ventilation is Essential



Proper Attic Ventilation

Proper attic ventilation systems allow a continuous flow of outside air through the attic, creating cooler attics in the summer and drier attics in the winter. Attic ventilation consist of a balanced system of **air intake** at the eaves or soffits at the bottom of the attic space and **air exhaust** through the ridge at the peak of the roof.



Ridge vent shingled over with Cobblestone Gray roof shingle.

Benefits

Helps reduce energy consumption

During warmer months, heat from the sun is absorbed by the roof and radiates into the attic. If not properly vented, it can radiate into the living space below the attic and negatively affect the comfort level inside the house, contributing to higher utility bills. A balanced ventilation system helps keep attic space cool by allowing a continuous flow that replaces hot air with fresh air, thereby reducing strain on your air conditioning units.

Protects against damage to materials and structure

The shingles and decking of your roof system may deteriorate prematurely due to heat and excessive moisture buildup. By reducing the surface temperature of the shingles in hot months, and keeping attics drier during colder months, ventilation reduces the amount of moisture in the attic space, extending the life of roof system materials.

Defends against ice dams



Ice dams are formed when heat from the inside of a home escapes into the attic and warms the roof decking during the winter. This heat, combined with heat from the sun, can melt snow on the roof. Melting snow then runs down toward the eaves as water. When it reaches the cold eaves and gutters, it refreezes.

This continual thaw and refreeze process creates ice dams. The result is water backing up under the roof shingles where it can soak through the roof decking or wall sheathing, causing damage to attics, ceilings, and walls.

Unfiltered Ridge Vent*

The CertainTeed Unfiltered Ridge Vent is designed with external baffles that maximize airflow across the underside of roof sheathing, and works year-round to ventilate the attic space and increase the longevity and performance of your roof. Less than an inch in height, this vent permits capping of the ridge with shingles to provide a roof with a complete, finished look.



Availability

12" Unfiltered Ridge Vent

FEATURES

- 12" Provides 18 square inches of net-free area per linear foot, and 9" provides 16 square inches of net-free area per linear foot
- Wind-driven rain resistant to 110 MPH
- Made from high-impact co-polymer material
- Pre-formed to a 4/12 pitch and fits pitches from 3/12 to 12/12
- Lifetime-limited warranty and 5-year SureStart™ Protection
- UL Classified, Miami Dade and Florida approved, TDI Windstorm listed product

Highest quality co-polymer remains sturdy, nailable, and flexible in all climates

Reinforced ribs for greater stability and rigidity

External wind baffle creates low air pressure and helps pull air out of the attic

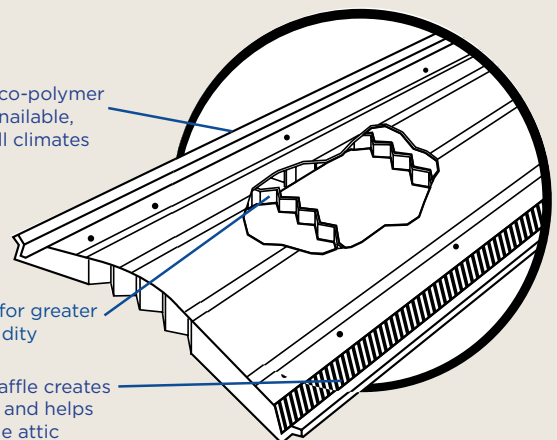

FILTERED EXHAUST VENTILATION

Filtered Ridge Vent*

The CertainTeed Filtered Ridge Vent offers the same performance as an Unfiltered Vent, with the added protection of an internal weather filter that provides ever greater protection from rain, snow, dust, and insect intrusion.

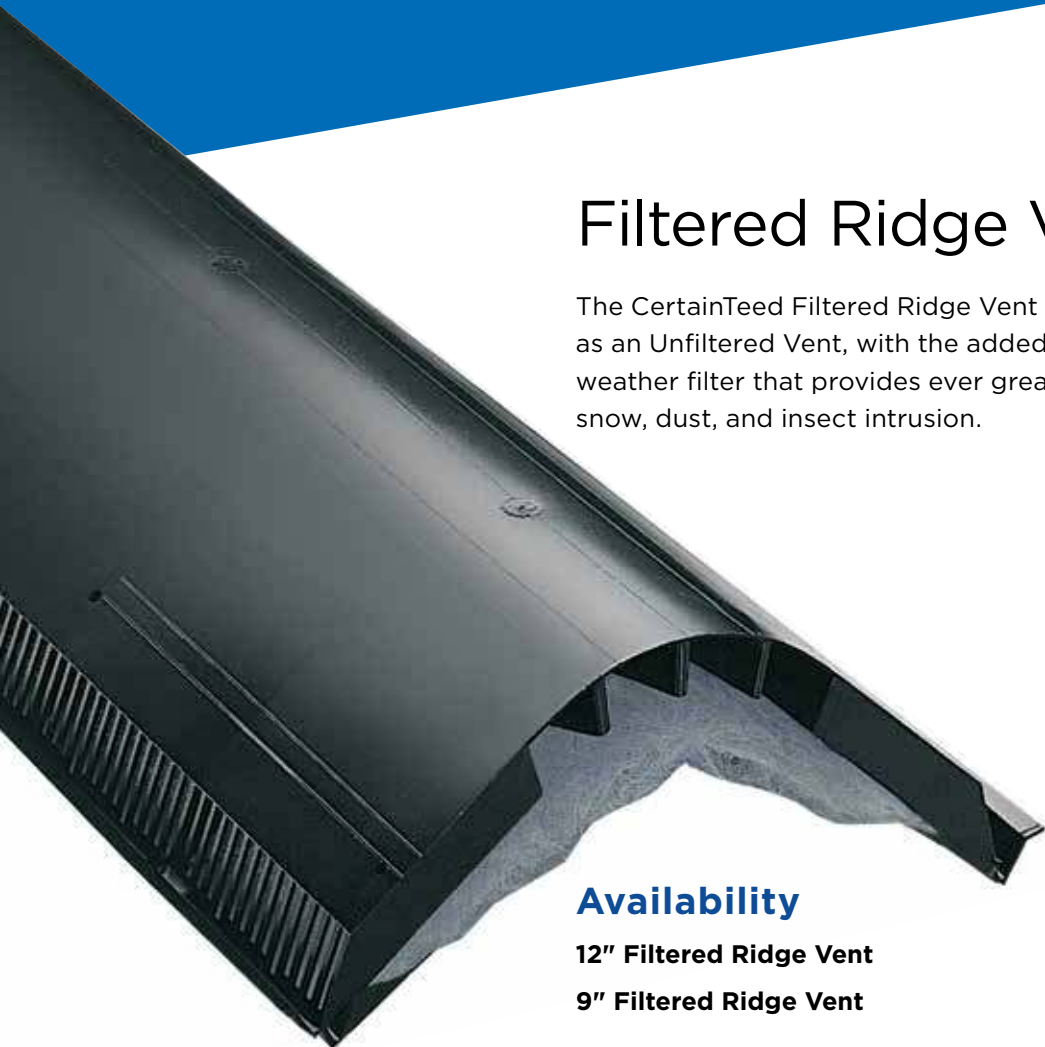

Availability

12" Filtered Ridge Vent

9" Filtered Ridge Vent

FEATURES

- 12" Provides 18 square inches of net-free area per linear foot, and 9" provides 16 square inches of net-free area per linear foot
- Wind-driven rain resistant to 110 MPH
- Made from high-impact co-polymer material
- Pre-formed to a 4/12 pitch and fits pitches from 3/12 to 12/12
- Lifetime-limited warranty and 5-year SureStart™ Protection
- CSA approval, UL Classified, Miami Dade and Florida approved, TDI Windstorm listed product

Highest quality co-polymer remains sturdy, nailable, and flexible in all climates

Reinforced ribs for greater stability and rigidity

Weather filter provides advanced protection from rain, snow, dust, and insect intrusion

External wind baffle creates low air pressure and helps pull air out of the attic

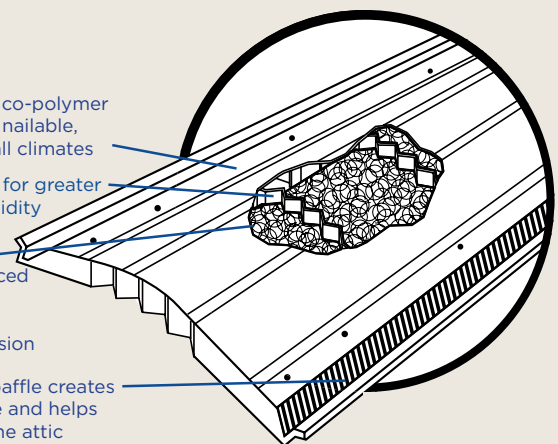

Class A Fire-Rated Ridge Vent*

The CertainTeed Class A Fire-Rated Ridge Vent offers the same performance of a Filtered Vent, but is engineered in accordance with UL manufacturing quality standards to fulfill code requirements for Class A fire-rated roof decks. It includes an internal weather filter that provides ever greater protection from rain, snow, dust, and insect intrusion.



Availability

9" Class A Fire Rated Ridge Vent - Available in NW and SW regions only

FEATURES

- 9" Provides 16 square inches of net-free area per linear foot
- Wind-driven rain resistant to 110 MPH
- Made from high-impact co-polymer material
- Pre-formed to a 4/12 pitch and fits pitches from 3/12 to 12/12
- Lifetime-limited warranty and 5-year SureStart™ Protection
- CSA approval, UL Classified, Miami Dade and Florida approved, TDI Windstorm listed product

Highest quality co-polymer remains sturdy, nailable and flexible in all climates

Reinforced ribs for greater stability and rigidity

Weather filter provides advanced protection from rain, snow, dust and insect intrusion

External wind baffle creates low air pressure and helps pull air out of the attic

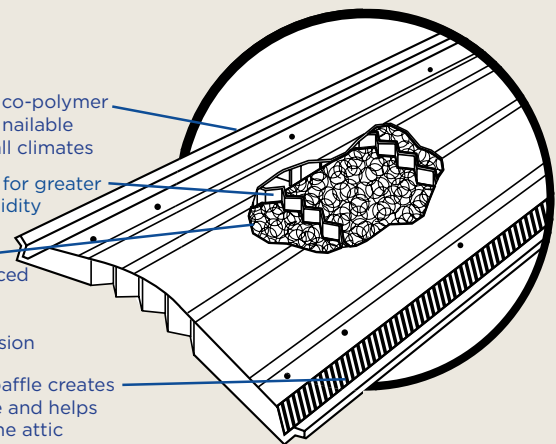

Meets UL manufacturing quality standards and code requirements for Class A fire-rated roof decks

EXHAUST VENTILATION



Unfiltered Rolled Ridge Vent*

CertainTeed's Unfiltered Rolled Ridge Vent features external baffles that maximize airflow through an attic space year-round to increase the longevity and performance of your roof. It is engineered with built-in, weather-tight ventilating end plugs that flex to complement different roof pitches. With a low-profile design only 3/4" high, this vent permits capping with 12" ridge shingles to provide a roof with a complete, finished look.



Filtered Rolled Ridge Vent*

The CertainTeed Filtered Rolled Ridge Vent offers the same performance as the Unfiltered Rolled Ridge Vent, with the added protection of an internal weather filter that provides ever greater protection from rain, snow, dust, and insect intrusion.

FEATURES

- Provides 12 square inches of net-free area per linear foot
- Roll length 28 feet
- Fits pitches from 3/12 to 12/12
- Limited Lifetime Warranty and 5-Year SureStart™ Protection
- Miami Dade and Florida approved

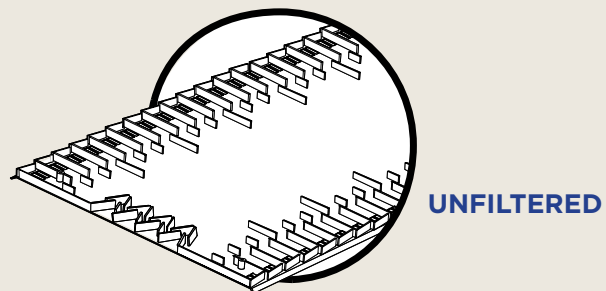
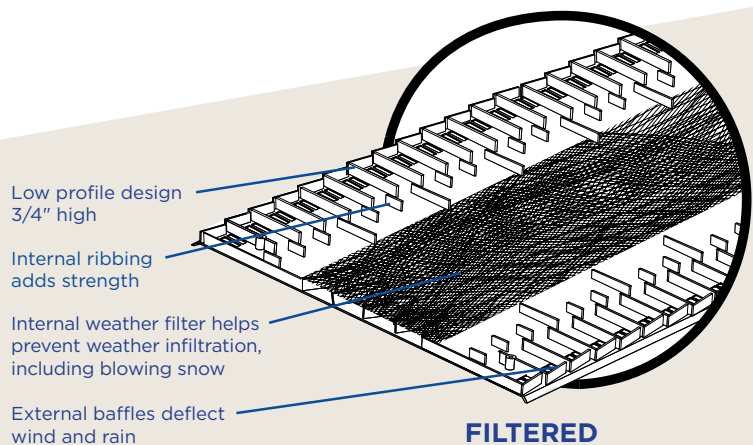

INTAKE VENTILATION



Intake Vent

The CertainTeed Intake Vent is a roof-top installed vent that can be used as a substitute for, or in complement to, soffit or under eave vents to supply fresh air into an attic space. Designed for homes with little or no roof overhang, it features internal baffles, an internal weather filter, and a drainage system for three levels of weather protection.

FEATURES

- Provides 9 square inches of net-free area per linear foot
- Requires a minimum 3/12 roof pitch, with no maximum
- Limited Lifetime Warranty and 5-Year SureStart™ Protection
- 3/4" low profile when installed onto the roof
- Strong, co-polymer construction
- TDI Windstorm listed product

Internal weather filter made of untreated, unwoven fiberglass to protect from weather infiltration

Internal baffles to protect from weather infiltration

Exhaust venting slots allow air to flow into attic through roof deck slot

Reinforced ribs for greater stability and rigidity

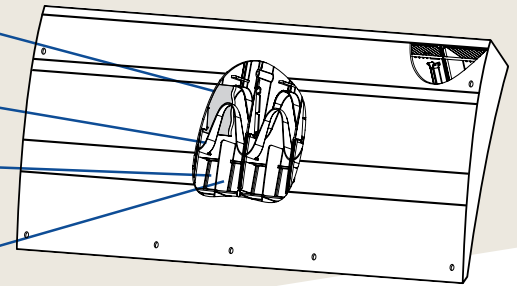

Triple 3-1/3" InvisiVent®

Vinyl Soffit

We offer a wide variety of soffit color and design options for your home, including our Triple 3-1/3" InvisiVent® and Perimeter™ Triple 3-1/3" hidden soffit vents. Each vented soffit product is designed to work in tandem with our exhaust ventilation products for a uniform flow of air through the attic space.

Triple 3-1/3" InvisiVent® panels offer a flat face design with a low gloss, matte finish that replicates the look of freshly painted wood. They offer the highest ventilation performance in their class, providing at least 50 percent more ventilation than most standard vinyl soffit.

- Provides more than 10 square inches of net-free intake area
- Available in 7 colors
- Class 1(A) fire rating
- Lifetime limited warranty



Perimeter™ Triple 3-1/3"

Perimeter™ Triple 3-1/3" panels have a smooth, non-perforated flat surface that can be installed as a solid soffit or as vertical siding. The post-formed lock design offers locking assurance and trouble-free handling.

- Provides up to 9.65 square inches of net-free intake area
- Available in 10 colors
- Class 1(A) Fire Rating
- Lifetime limited warranty



Integrity Roof System™

PERFORMANCE ENGINEERED FOR COMPLETE PROTECTION,
STRONG RESILIENCE AND LASTING BEAUTY



With as much care as you take in selecting the right contractor, choosing the right roof system is equally as important. A CertainTeed Integrity Roof System combines key elements that help ensure you have a well-built roof for long-lasting performance.

1. Waterproofing Underlayment

The first step in your defense against the elements. Self-adhering underlayment is installed at vulnerable areas of your roof to help prevent leaks from wind-driven rain and ice dams.

2. Water-Resistant Underlayment

Provides a protective layer over the roof deck and acts as a secondary barrier against leaks.

3. Starter Shingles

Starter Shingles are the first course of shingles that are installed and designed to work in tandem with the roof shingles above for optimal shingle sealing and performance.

4. Shingles

Choose from a variety of Good-Better-Best styles to complement any roof design and fit your budget.

5. Ventilation

A roof that breathes is shown to perform better and last longer. Ridge Vents, in combination with Intake Vents, allow air to flow on the underside of your roof deck, keeping the attic cooler in the summer and drier in the winter.

6. Hip & Ridge Caps

Available in numerous profiles, these accessories are used on the roof's hip and ridge lines for a distinctive finishing touch to your new roof.

For help calculating
proper ventilation needs,
please scan the QR code.



learn more at:

certainteed.com/roofing



CertainTeed

Ceilings • Gypsum • Insulation • Roofing • Siding • Trim
20 Moores Road, Malvern, PA 19355 | 800-233-8990 | certainteed.com

©10/25 CertainTeed, Printed in the USA, Code No. 00-00-536-NA-EN



A PROGRAM OF IBHS

*These products are part of CertainTeed's
FORTIFIED™-Compliant Roof System
for enhanced protection
(applicable to the U.S. only).