

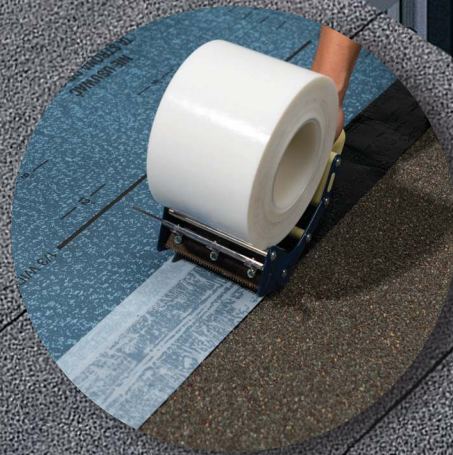

Flintlastic[®] SA

Self-Adhered Roof Systems
for Low-Slope
Residential Roofs

Installs in temperatures
as low as 35°F (2°C) with
the use of Arctic Edge



Flintlastic® SA Cap Colors

Flintlastic® SA Cap Colors

Flintlastic SA Cap is available in a variety of “true-blend” colors to complement popular CertainTeed shingles.

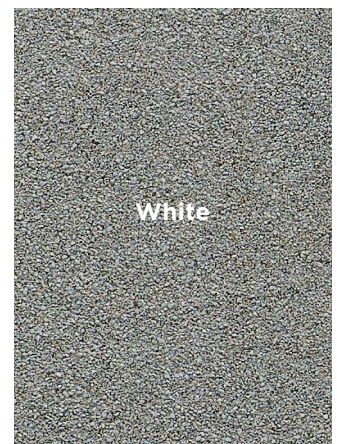
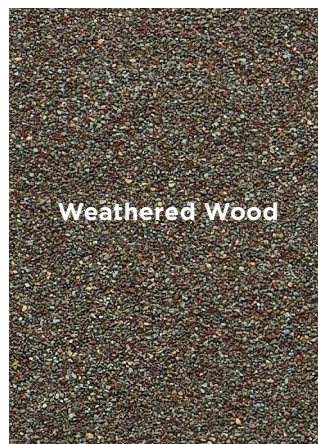
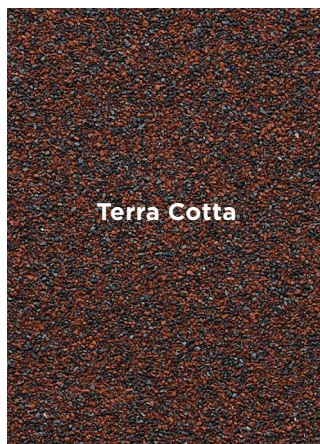
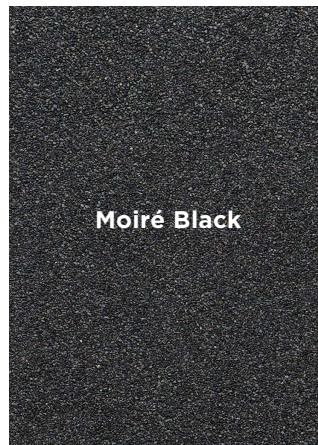
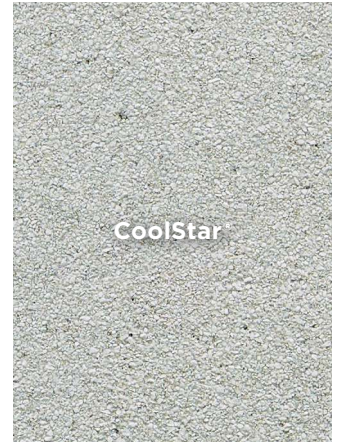
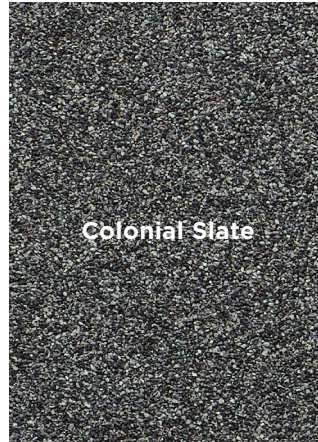
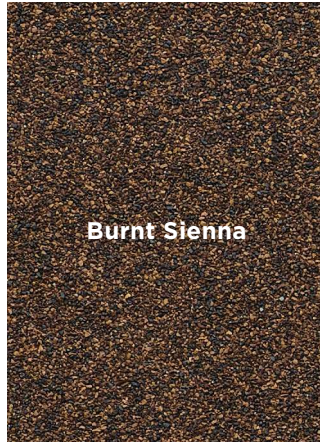

When To Use

Flintlastic® SA Components & When to Use

CertainTeed Flintlastic® SA is a premium, self-adhered SBS-modified bitumen roofing system. With high quality materials bottom to top, components of the Flintlastic SA system include:

BASE/ANCHOR & INTERPLY SHEETS			
Product	Use When:	Weight/Unit	Coverage/Volume
Flintlastic® SA NailBase	Roof deck is nailable, such as plywood, and best practice is to mechanically attach a base sheet.	82 lbs.	2 squares
Flintlastic SA PlyBase	Base ply will be fully adhered and desired warranty duration is 15-years; may also function as interply in 3-ply systems.	86 lbs.	2 squares
Flintlastic SA MidPly	Base ply will be fully adhered and desired warranty duration is 20-years; may also function as interply in 3-ply systems.	63 lbs.	1 square

CAP SHEETS			
Product	Use When:	Weight/Unit	Coverage/Volume
Flintlastic SA Cap	Color matching shingles is a priority and extreme protection against fire and hail are not needed.	95 lbs.	1 square
Flintlastic SA Cap CoolStar®	High solar reflectivity is a priority and extreme protection against fire and hail are not needed.	93.5 lbs.	1 square
Flintlastic SA Cap FR	Extreme protection against fire and hail are desired.	88 lbs.	1 square
Flintlastic SA Cap FR CoolStar	High solar reflectivity and extreme protection against fire and hail are desired.	88.5 lbs.	1 square

PRIMERS & ADHESIVES			
Product	Use When:	Weight/Unit	Coverage/Volume
FlintPrime QD	Priming the roof deck is required or desired prior to the direct adhesion of Flintlastic SA PlyBase or MidPly.	50 lbs.	5G, 666 sq. ft.
FlintPrime Aerosol	Quickly priming small details such as fastener heads or metal detail surfaces prior self-adhering on top.	1.25 lbs.	15 oz., 18 sq. ft.
FlintBond® Caulk or Trowel	Preparing granulated surfaces for self-adhered overlaps (Trowel) and sealing detail edges (Caulk).*	88 lbs.	10.1 oz., 24 lf. (1/4" bead); 3G, 120 lf. (4" wide, 1/8" thick); 5G, 200 lf. (4" wide, 1/8" thick)
Arctic Edge Cold Lap Tape	Ambient temperatures are below 49°F (9°C), see cold weather instructions	3 lbs.	8 squares

*A hot air welder, in combination with a hand-held silicone roller, may also be used for these details in lieu of FlintBond and is required for cold weather application, in addition to Arctic Edge Cold Lap Tape.

Where & Why

Where can I use it?

The value associated with labor savings and safety can be applied to any roof project. In addition, Flintlastic SA roof systems are ideal when access to the roof is limited, such as high-rise buildings. And no asphalt kettle means no odor, which makes SA systems an ideal solution on healthcare, education, hospitality and residences/condos where occupant comfort is tremendously desirable.

What Are The Advantages?

Self-adhered roofing offers the time-tested protection of modified bitumen roof systems for a fraction of the labor with no fumes, flame, asphalt kettle or occupant disturbance. The application of self-adhered low-slope roof systems is also easier to master than traditional bituminous application methods.

Flintlastic SA systems are valued for:

- Superior initial and long-term bonds;
- Excellent applicator handleability in hot or cold temperatures;
- Allowed application temperatures as low as 35°F (cold weather application instructions must be followed when ambient temperatures are between 35°F - 49°F);
- Wide array of cap sheet colors true-blended to complement popular CertainTeed shingles
- National stocking at all CertainTeed facilities with mix-truck allowance (shingles/Flintlastic SA);
- Excellent sales and applicator support.

Energy Savings

Flintlastic SA Cap and SA Cap FR are available with CoolStar highly reflective granules. Specific product details can be found on product technical data sheets or by viewing www.coolroofs.org.

POPULAR LOW-SLOPE RESIDENTIAL SA SYSTEMS ON WOOD DECKS

Warranty Duration	Base Sheet	Base Ply	Interply	Cap
10 ¹	—	—	—	SA Cap (FR)
12	SA NailBase	—	—	
15 ²	SA NailBase	—	SA PlyBase ³	
20 ²	SA NailBase	—	SA MidPly ³	

¹Sure Start™ Limited Warranty coverage is limited to twenty (20) squares.

²Sure Start Plus 3, 4 or 5 STAR Limited Warranty Coverage is limited to ten (10) squares.

³Direct adhesion to wood, without the inclusion of the base sheet, is permitted and requires priming with FlintPrime QD; roof systems self-adhered to wood decks are limited to Sure Start Limited Warranties; direct adhesion to wood is not permitted by code in Miami-Dade County (check your local building code); at the end of the roofing membrane's life, roofing membranes directly adhered to wood roof decks will require replacement of the deck; self-adhering to wood plank decks constructed of resinous woods, such as pine, is prohibited.

Cold Weather Considerations

Arctic Edge™ Flintlastic SA Cold Lap Tape

Flintlastic® SA self-adhered membranes deliver an excellent bond when ambient temperatures are 50°F and rising. Arctic Edge™ is a revolutionary auxiliary tape engineered to significantly boost Flintlastic SA adhesion in temperatures as low as 35°F.

Cold Weather Application Fundamentals

- Cold weather application instructions shall be followed when ambient temperatures are below 49°F (9°C)
- **NEVER INSTALL COLD ROLLS**
Store rolls, tape and adhesives in a heated location and draw as needed; if materials have been exposed to cold temperatures, allow to warm to a minimum 50°F (10°C) in a heated environment before use; never use a torch to heat rolls
- Arctic Edge is used with self-adhering membranes; Arctic Edge is not used to install Flintlastic SA NailBase which is mechanically attached
- Arctic Edge is permitted to support adhesion to all approved Flintlastic SA substrates; see Flintlastic SA Low-Slope Substrate Guidelines Technical Bulletin
- Granule overlaps, such as, but not limited to, cap sheet end laps, require the use of a hot air welder and silicone roller; Arctic Edge does not adhere to granules

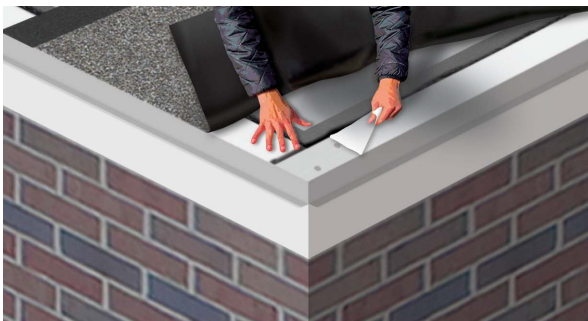

Perimeter/Metal Details



Base/Interply Side Laps



Base/Interply End Laps



Cap Side Laps



Scan for Comprehensive
Application Instructions & Video

Pre-Application Considerations

SA-Specific Tools

- A weighted roller for pressing the membrane into place, 2" to 4" in diameter (70 lbs.);
- Suitable trowel for applying FlintBond to flashing details;
- Roofer's knife with hooked blade;
- Caulk gun for applying beads of FlintBond;
- Seam probing tool to check for voids;
- Hot Air Welder for cold weather applications or, if preferred, for flashing details year round;
- **AS NEEDED:** Long-handled (standing) roller with 1/8"- 1/4" nap for applying primer (1/8" nap for smooth surfaces, 1/4" nap for more porous surfaces).

Storage

- Store Flintlastic SA rolls indoors on upright pallets, protected from the elements. Improperly stored rolls or those that have been warehoused for prolonged periods of time may lose their tack and should not be used.
- In cold weather, rolls MUST be stored indoors, minimum 60°F, or in warming huts prior to application. Allow material to relax a minimum of 15 minutes prior to installation. Avoid allowing rolls to fall below 50°F to avoid material contraction.

General Precautions

- Do not attempt application if ice, snow, moisture, or dew are present.
- When ambient temperatures are between 35°F and 49°F, cold weather application instructions must be followed. See *Flintlastic SA Cold Weather Applicator Guide*.

- NEVER INSTALL COLD ROLLS. If ambient temperatures are below 50°F, ensure rolls are kept in a heated location and draw materials as needed. If exposed to cold temperatures, allow a sufficient time for them to warm to 50°F. Never use a torch to heat rolls.
- Flintlastic SA membranes are designed to be applied together in fully self-adhered roof systems. Flintlastic SA base sheets may also be used in hybrid roof systems with a torch-applied cap. However, Flintlastic SA base sheets cannot be paired with cap sheets applied with hot asphalt or cold adhesive. Flintlastic SA Cap (or SA Cap FR) cannot be applied to any other base sheets other than as described here.
- Cut rolls to manageable lengths and allow to relax, unrolled, at a minimum 50°F ambient temperature, for a minimum of 15 minutes prior to installation.
- All plies of the assembly should be installed in one day. If any other base sheet must be exposed for longer periods of time, cover with tarp or suitable alternate protection.
- Substrates must be free of dust, dirt, oil, debris and moisture.
- When applying Flintlastic self-adhered membranes on slopes exceeding 1" in 12", membranes shall be back nailed (see Appendix for detail).
- When applied parallel to the slope, Flintlastic self-adhered membranes shall be blind-nailed at end laps 2" in from top edge, 6" o.c. through tin discs and to wood nailers. (See General Requirements Section of *CertainTeed Commercial Roof Systems Specifications* manual for details.)
- If the material isn't bonding, **STOP** the application immediately!
- Refer to Field Details Reference for width of starting course to ensure sidelaps within the roof system are staggered/offset from each other

Primers & Adhesives

- If primer is used, it must be applied at the specified rate and be allowed to cure as specified.
- When using FlintBond for flashing details, target 1/4" FlintBond bleed out at endlap areas. Be careful not to roll weighted roller into bleed out.

Do not use cold adhesives, such as FlintBond, with Flintlastic self-adhered membranes other than for flashing details and cap sheet overlaps as described here.

FIELD DETAILS REFERENCE

	2-PLY SYSTEMS		3-PLY SYSTEMS		
	Base	Cap	Base	Ply	Cap
Starter row width	19-11/16" (1/2 roll)	39-3/8" (full roll)	26-1/4" (2/3 roll)	19-11/16" (1/2 roll)	39-3/8" (full roll)
Side laps	2"	3"	2"	2"	3"
End laps, staggered 36"	4"	6"	4"	4"	6"



Base Application

Base Sheet - Mechanically Attached

Prior to application of the base sheet, inspect the roof substrate to make sure it is free of dust, dirt, oil, debris and moisture. **Refer to Field Details Reference** for width of starter course.

Begin at the low point of the roof. Position base to allow for a 2" overhang at perimeter edges. Mechanically fasten Flintlastic SA NailBase to nailable deck using appropriate fasteners (**see Fasteners Chart**).

Install so that no sidelaps are against the flow of water. A minimum fastening pattern is every 9" on

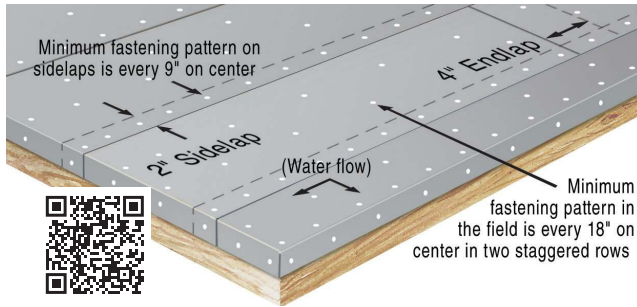

FASTENER CHART

Standard (Round Head) Roofing Nails and Cap
 (Note: CertainTeed does not permit the use of plastic caps)
 For use with Base Sheet, Flash/Termination Bar on Plywood Decks, Non Veneer Decks, Wood Plank Decks



Large Head Roofing Nails

For use with Base Sheet, Flash/Termination Bar on Plywood Decks, Non Veneer Decks, Wood Plank Decks

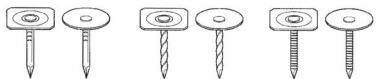

Base Sheet Fasteners for some Cementitious Roof Decks

For use with Base Sheet on Light Weight Insulation Concrete, Poured Gypsum



Self-Locking Fasteners

For use with Base Sheet on Cement/Wood Fiber



Insulation Fasteners



center on sidelaps and every 18" on center in two staggered rows in the field of the sheet. Overlap base sheet sidelaps a minimum 2" and endlaps 4". Turn base sheet over fascia by 2" and fasten. Offset endlaps of adjacent courses a minimum of 3'.

Do Not Leave Base Sheet Exposed To The Weather. Cover in the same day with optional SA interply and/or SA Cap (FR).

Base Ply - Self-Adhered

SA PlyBase or SA MidPly may be self-adhered to approved substrates. (**See Approved Substrates Reference table.** In accordance with published exclusions from warranty coverage CertainTeed shall not be held responsible for failure caused by settlement, deflection, movement, moisture content, inadequate attachment, or other deficiencies of the roof deck, preexisting roof system, walls, foundations or any other part of the building structure, insulation or other materials underlying the product.)

APPROVED SUBSTRATES FOR DIRECT ADHESION REFERENCE

Base Sheets

- Flintlastic® SA NailBase • Flintlastic SA PlyBase • Flintlastic SA MidPly

Insulation

- FlintBoard® ISO & ISO Cold (polyisocyanurate insulation)

Cover Board

- High density fiberboard (ASTM C208 & 209 – primed boards only)
 - i.e. STRUCTODEK® High Density Fiberboard with Primed Red Coating²
- Asphalt coated cover boards
- Gypsum based cover board products (priming may be required):
 - USG Securock® Gypsum-Fiber Roof Board
- Georgia Pacific DensDeck® Roof Boards:
 - DensDeck (priming is required)
 - DensDeck Prime (priming is not required but will enhance adhesion)
- Zip System® Sheathing²
- FlintBoard HD or High density polyisocyanurate (ASTM C1278, Type II, Class 4)

Decks

- Structural concrete decks* (priming is required)
 - *Lightweight Structural Concrete is subject to greater moisture content and not acceptable for direct adherence of Flintlastic SA self-adhering products
- Wood¹ (priming is required)
 - Approved Wood Types:
 - APA Rated Exterior Grade Plywood
 - APA Rated Exterior Grade Oriented Strand Board (OSB)

Precautions: Direct adhesion is not permitted by code in Miami-Dade County; check your local building code); At the end of the roofing membrane's life, roofing membranes directly adhered to wood roof decks will require replacement of the deck. Self-adhering to wood plant decks constructed of resinous woods, such as pine, is prohibited.

¹ Please refer to reverse side for CertainTeed Flintlastic SA Limited Warranties on wood substrates.

² When self-adhering direct to these substrates, eligible for Asphaltic Membrane Ltd. Warranty on Materials and Asphaltic Membrane Limited Warranty on Systems only.

Base Application



When self-adhering direct to a plywood deck, Flint-Prime QD is required.



Begin at the low point of the roof. Position base to allow for a 2" overhang at perimeter edges.



Before adhering a base ply, sweep the surface of the deck or insulation to remove any debris that could interfere with adhesion. Refer to **Field Details Reference** for starter course width.

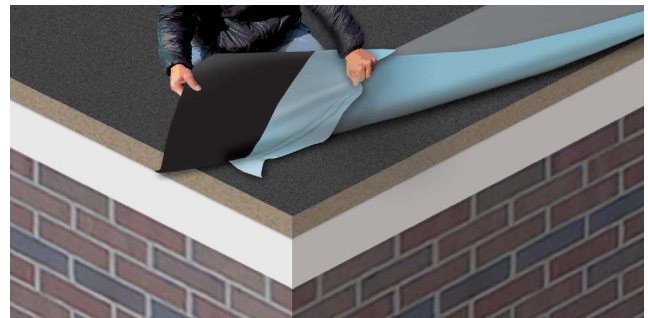

Fold the membrane back halfway lengthwise to remove the split release film.



Press membrane securely into place and repeat with the opposite half of the membrane. Turn base ply over fascia by 2" and fasten.

Base Application



Use a heavy, weighted roller over the entire surface of the PlyBase or MidPly to secure the membrane. Work from the center of the roll outwards across the width to eliminate air pockets; **DO NOT** roll lengthwise as it can cause the roll to stretch.



Overlap sidelaps of subsequent SA PlyBase or SA MidPly membrane courses a minimum 2'' and endlaps 4''. Offset endlaps of adjacent courses a minimum 3'.

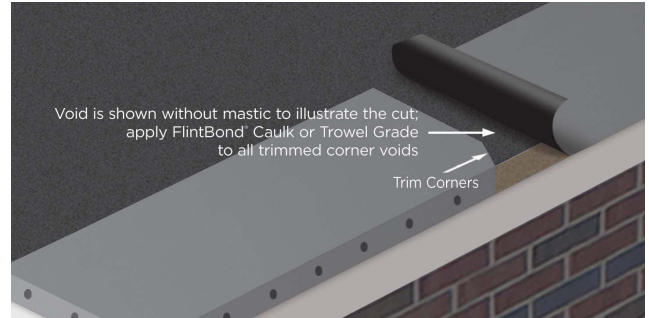

Cut endlaps at opposing diagonal corners at an angle approximately 5-1/2'' long by the over lap dimension (2'' or 3'') to minimize water incursion at T-seams. See Appendix CT-22 ENDLAP DETAIL.

Apply a bead or small trowel dab (quarter size) of FlintBond SBS-Modified Bitumen Adhesive, Caulk or Trowel grade, at the edge of the angled cut. Use of a hand-held hot air gun at the joint area prior to rolling the membrane will maximize adhesion. It is recommended to apply a bead of FlintBond® SBS-Modified Bitumen Adhesive, Caulk grade, at all SA PlyBase or SA MidPly side and endlaps edges to eliminate a capillary.

Do Not Leave Base Sheet Exposed To The Weather. Cover in the same day with optional SA interply and/or SA Cap/SA Cap FR.

Interply Application

Optional, Specification and Warranty Duration Dependent

Note: Proceed to “Before Installing Flintlastic® SA Cap (or SA Cap FR)” if installing a 2-ply system. Before installing interply, sweep the underlying base sheet/ply to remove any debris that could interfere with adhesion. Refer to **Field Details Reference** for starter course width.



Begin at the low point of the roof. Position interply flush to roof edge. Install so that no sidelaps are against the flow of water.



Fold the membrane back halfway lengthwise to remove the split release film.



Press membrane securely into place and repeat with the opposite half of the membrane.



Use a heavy, weighted roller over the entire surface to secure the membrane. Work from the center of the roll outwards across the width to eliminate air pockets; **DO NOT** roll lengthwise as it can cause the roll to stretch.



Overlap sidelaps of subsequent SA PlyBase or SA MidPly membrane courses a minimum 2" and endlaps 4". Offset (stagger) endlaps of adjacent courses a minimum 3'.

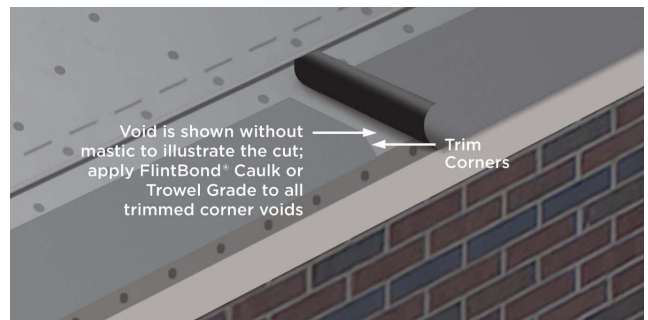

Cut endlaps at opposing diagonal corners at an angle approximately 5-1/2" long by the overlap dimension (2" or 3") to minimize water incursion at T-seams. See Appendix, CT-22 ENDLAP DETAIL. Apply a bead or small trowel dab (quarter size) of FlintBond® SBS Modified Bitumen Adhesive, Caulk or Trowel grade, at the edge of the angled cut.

Edge Metal Application

Use of a hand-held hot air gun at the joint area prior to rolling the membrane will maximize adhesion.



It is recommended to apply a bead of FlintBond® SBS Modified Bitumen Adhesive, Caulk grade, at all SA PlyBase or SA MidPly side and endlap edges to eliminate a capillary.

Do Not Leave Base Sheet Exposed To The Weather. Cover in the same day with SA Cap (FR).

If roof edge detail utilizes edge metal, proceed as follows.

Edge Metal for Two-Ply Systems (with no interply)



If an interply is not installed, adhere a 9" wide flashing strip of SA PlyBase or SA MidPly (material assumed to match base sheet if fully adhered) onto the field of the roof and flush to the roof edge; miter cut at corners to avoid overlap. Install minimum 26 gauge edge metal using appropriate fasteners, set entirely in a uniform 1/8" - 1/4" thick troweling of FlintBond. Fasten edge metal into the deck using appropriate fasteners (**see Fastener Chart**), spaced 4" on center in two staggered rows. See Appendix CT-01 EDGE FLASHING. Remove any oil from the metal surface using a vinegar and water solution. Prime the horizontal surface of the metal with FlintPrime Aerosol and allow primer to dry/tackify.



Edge Metal for Three-Ply Systems (with interply)

If an interply has been installed, install minimum 26 gauge edge metal using appropriate fasteners and set entirely in a uniform 1/8" - 1/4" thick troweling of FlintBond. Fasten edge metal through the metal surface, into the deck using appropriate fasteners (**see Fastener Chart**), spaced 4" on center in two staggered rows. Remove any oil from the metal surface using a vinegar and water solution. Prime the horizontal surface of the metal with FlintPrime® Aerosol and allow to dry/tackify.

Cap Application

Before installing Flintlastic® SA Cap or SA Cap FR, sweep the underlying sheet to remove any debris that could interfere with adhesion. Refer to **Field Details Reference** for starter course width.



Begin at the low point of the roof. Position cap flush to roof edge with selvage edge at high side of the roof. Install so that no sidelaps are against the flow of water.



Fold back lower half of the cap to remove the split release film.



Press cap securely into place and repeat with the opposite half.



Use a heavy, weighted roller over the entire surface to secure the membrane. Work from the center of the roll outwards across the width to eliminate air pockets; **DO NOT** roll lengthwise as it can cause the roll to stretch.



Overlap sidelaps of subsequent courses a minimum 3" and endlaps 6". Offset endlaps of adjacent courses a minimum 3". As subsequent membranes are installed, remove the selvage edge release strip just prior to overlapping to keep the adhesive area protected and clean.

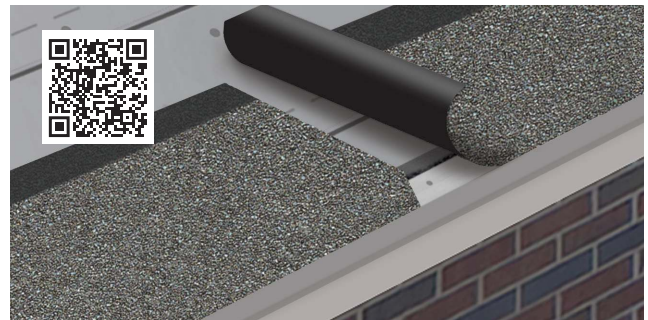

Cut endlaps at opposing diagonal corners at an angle approx. 3" by 5-1/2" from the corners to minimize water incursion at T-seams. Treat rake edge application similarly, cutting diagonal corners off Cap selvage edge above rake metal.

Cap Application

One of the following options must be followed for any granule over granule overlap, such as an endlap:



1. Apply a uniform 1/8" - 1/4" troweling of FlintBond® adhesive to the entire 6" width of the underlying sheet, extending beyond underlying lap 1/4" or;



2. Apply heat from a hot-air welder with a 2" tip to the overlapped sheet while applying rolling pressure from a silicone roller to the overlapping sheet. With the hot air welder set between 900°F-1,100°F (setting 8-10), apply heat to the overlapped granulated surface while bonding the overlapping cap with rolling pressure. Roll the overlapping SA Cap in place, moving the hot air welder to allow for forward progress. Avoid applying so much heat or moving at a pace that results in smoke. A 6" endlap requires three passes. Apply a bead of FlintBond® Caulk along the edge.

WHEN AMBIENT TEMPERATURES ARE BETWEEN 35°F - 49°F THE HOT-AIR WELDER METHOD MUST BE APPLIED. (See Flintlastic SA Cold Weather Applicator Guide for further details.)

Once the membrane has had a chance to bond, check all laps and joints for full adhesion. If the membrane can be lifted at any area it is not properly adhered. A seam probing tool can be helpful to check for voids at laps. If necessary, use appropriate hand-held hot air welding tool and seam roller or an application of FlintBond to seal unbonded areas if they exist.

Construction Details

Included in this manual are a few common construction details. Please refer to CertainTeed Low-Slope Applicator Guide or certainteed.com for complete details. Important to note with all details;

- All metal must be primed and set in FlintBond Trowel adhesive and
- All overlaps over granule surfacing must utilize either FlintBond® Trowel or the combination of a hot-air welder and silicone roller (cold weather requirement).

Construction Details

Included in this manual are a few common construction details. Please refer to *CertainTeed Low-Slope Applicator Guide* or certainteed.com for complete details. Important to note with all details,

- All metal must be primed and set in FlintBond Trowel adhesive
- All overlaps over granule surfacing must utilize either FlintBond Trowel or the combination of a hot-air welder and silicone roller (cold weather requirement).

Typical Construction Details - Flintlastic® SA 2 Ply Systems

CT-01 Edge Flashing

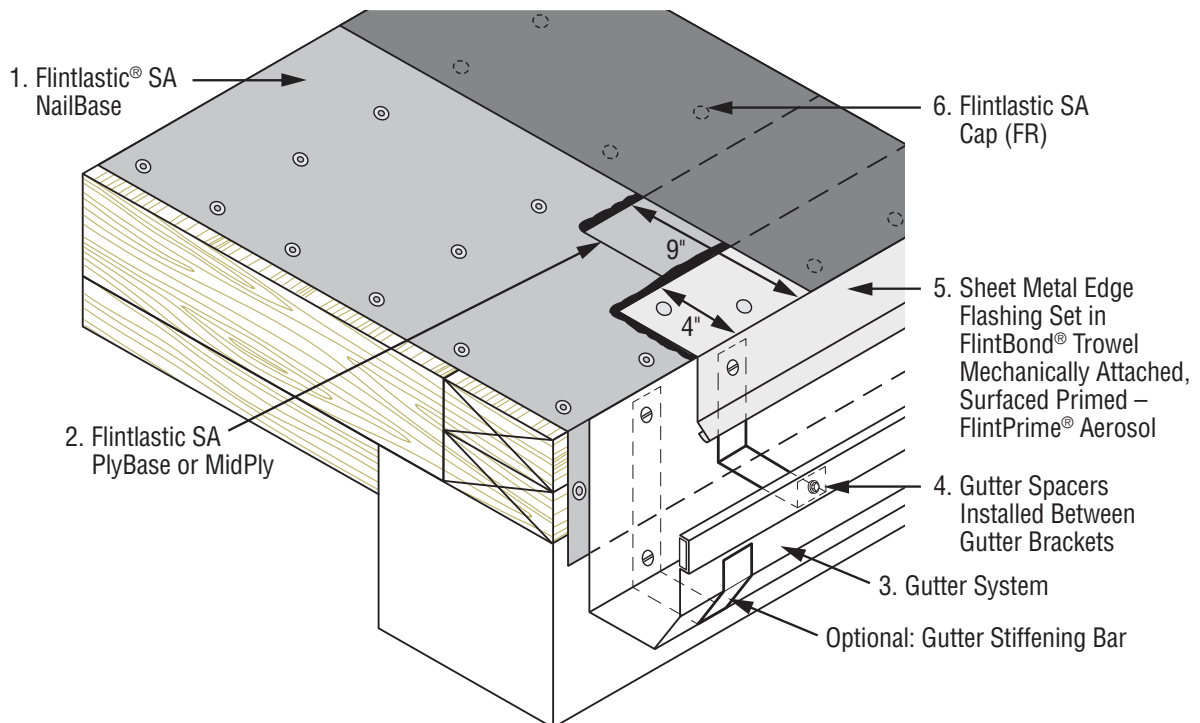
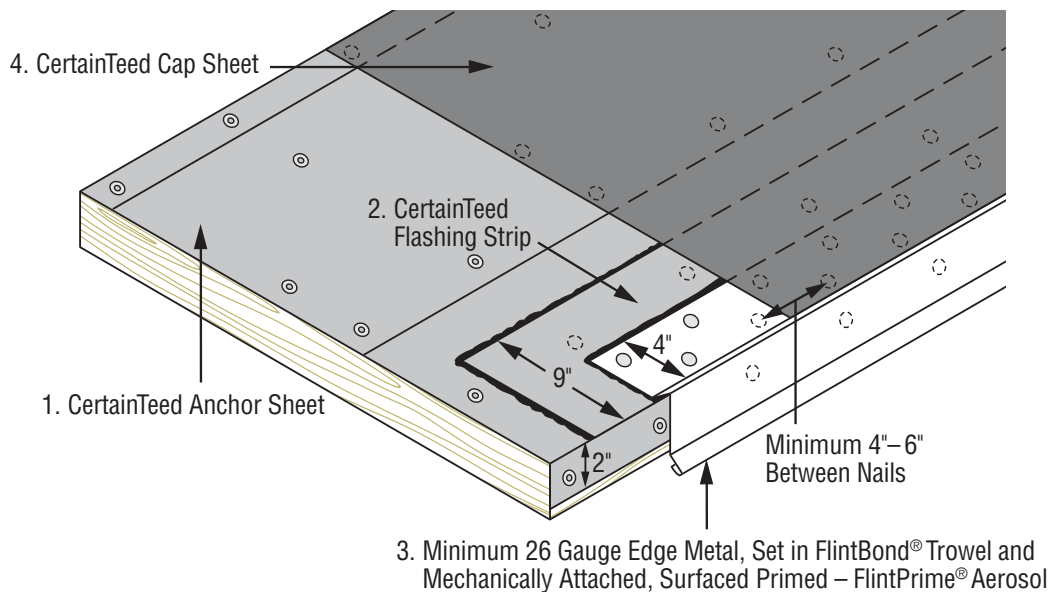

CT-01B Edge Flashing - Gutter

Typical Construction Details - Flintlastic® SA 2 Ply Systems

CT-23 Steep to Low-Slope Roof Transition Flashing

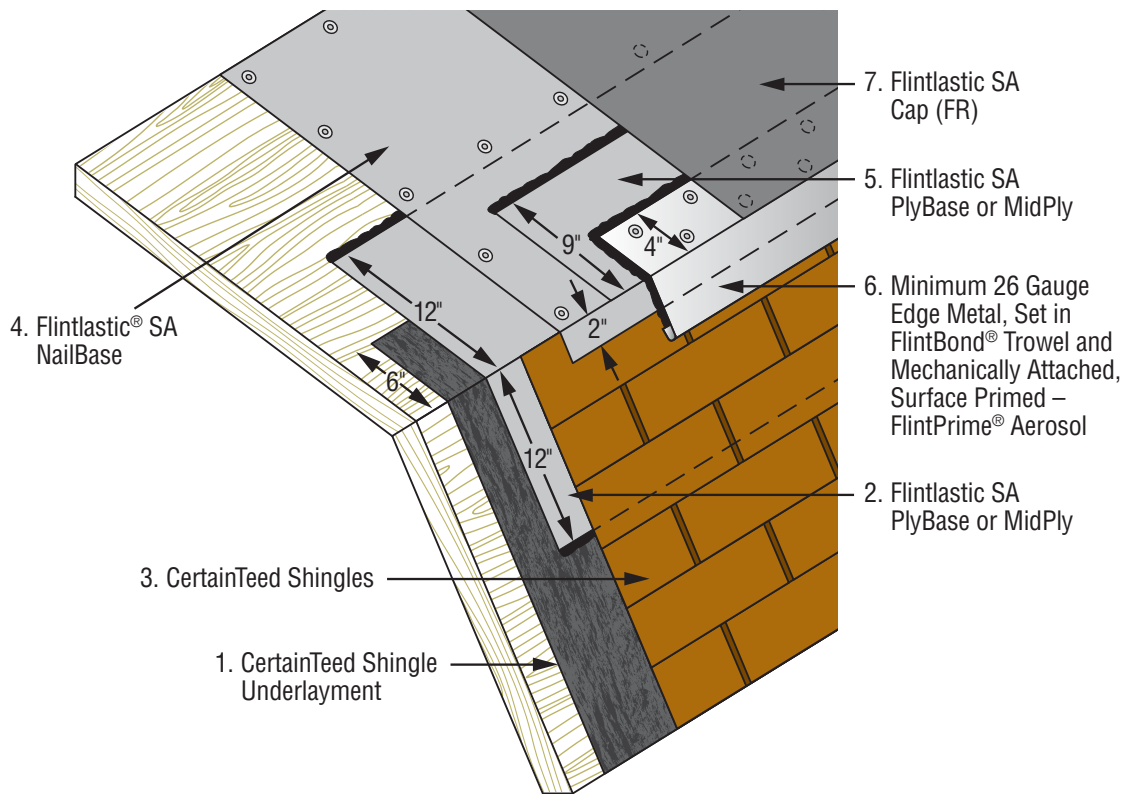
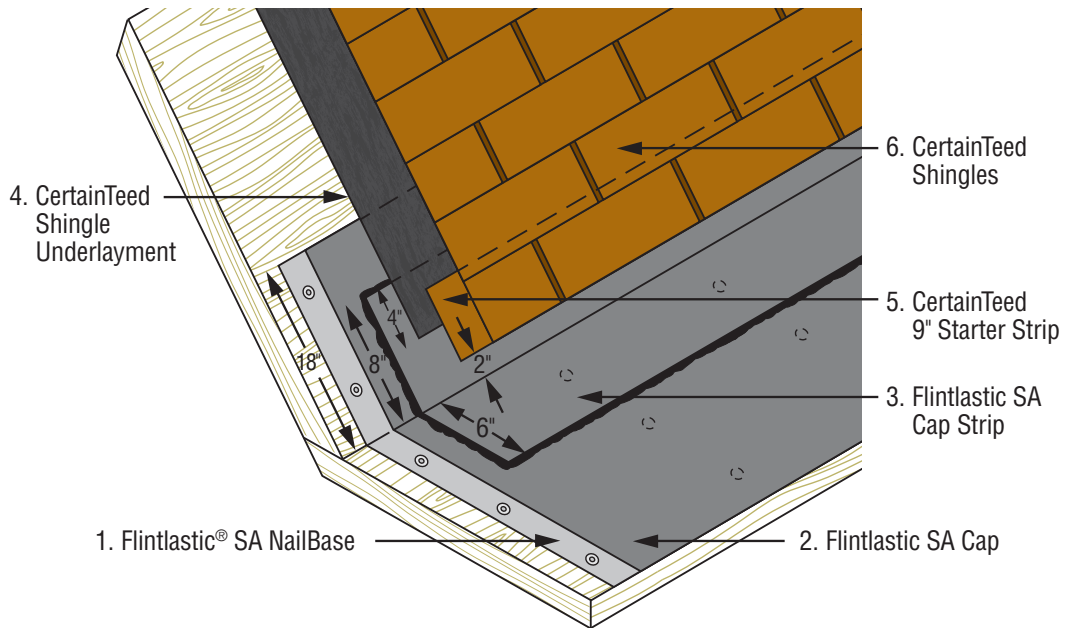

CT-24 Mansard Roof Transition Flashing

Typical Construction Details – Flintlastic® SA 2 Ply Systems

CT-29A Back Nailing – Nailable Substrates

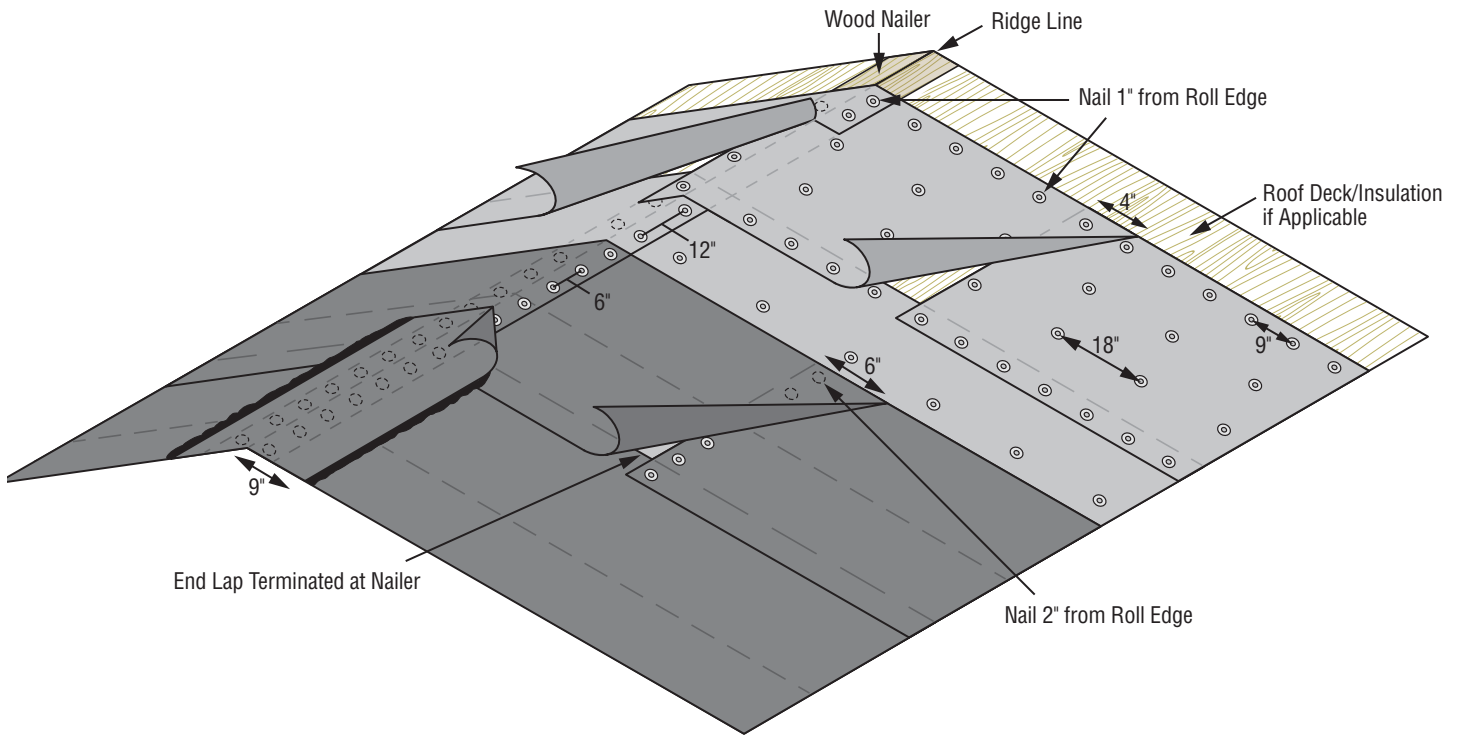

Typical Construction Details – Flintlastic® SA 3 Ply Systems

CT-01 Edge Flashing

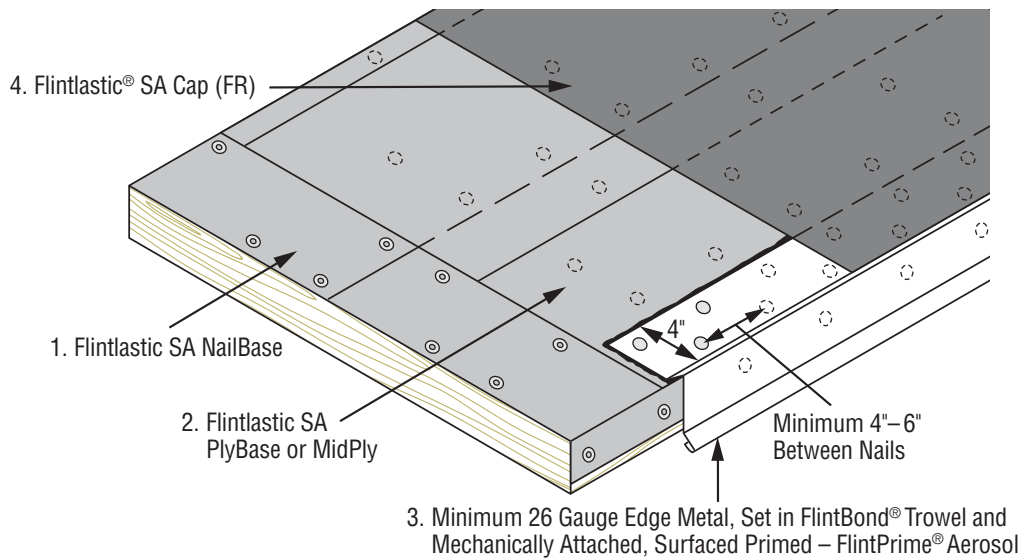

Typical Construction Details – Flintlastic® SA 3 Ply Systems

CT-01B Edge Flashing – Gutter

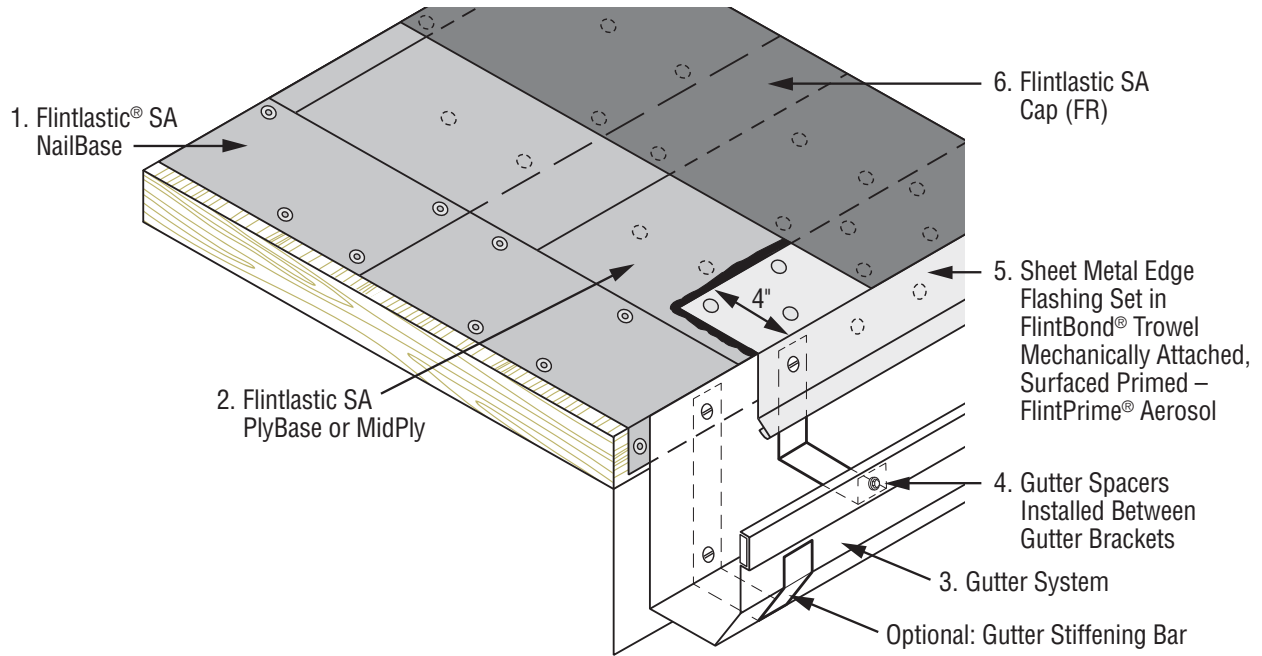

Typical Construction Details – Flintlastic® SA 3 Ply Systems

CT-13 Pipe Flashing – Lead or Sheet Metal

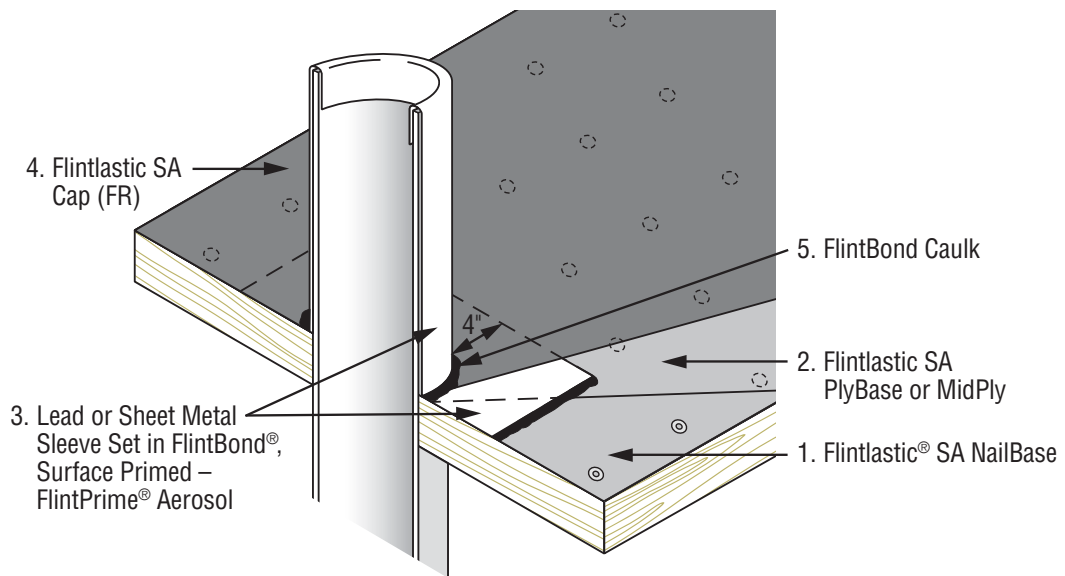

Typical Construction Details – Flintlastic® SA 3 Ply Systems

CT-23 Steep to Low-Slope Roof Transition Flashing

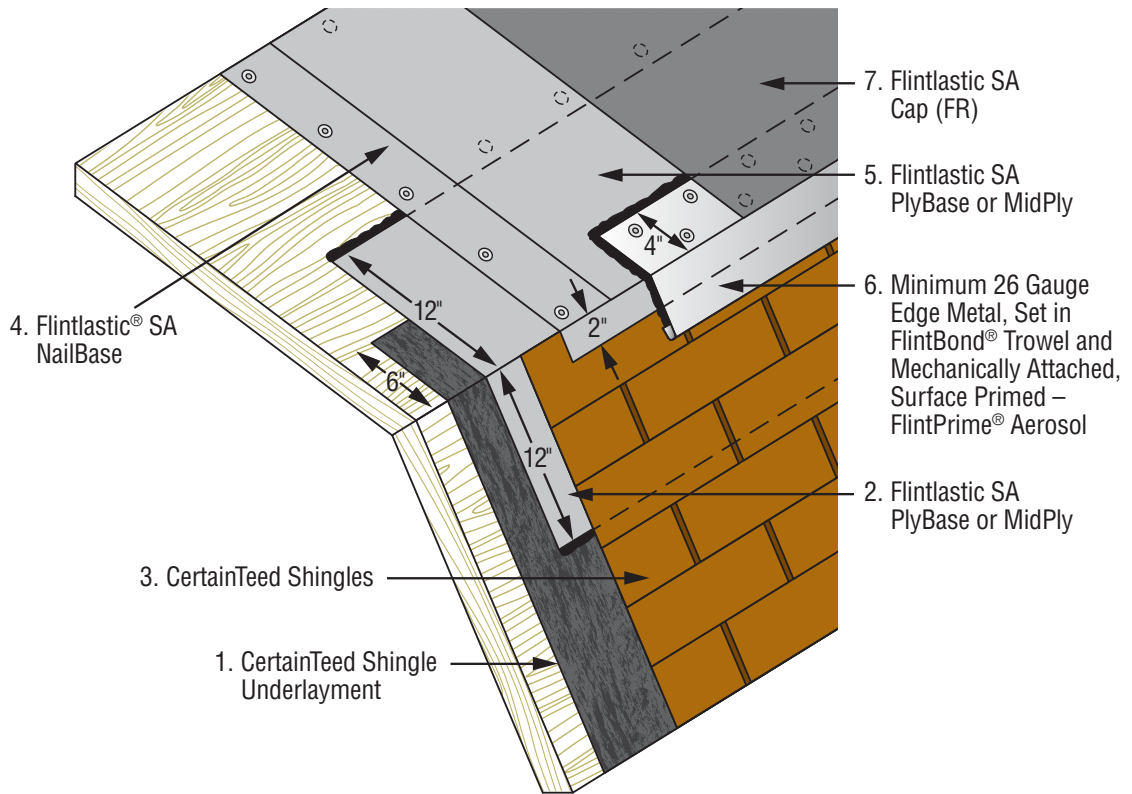
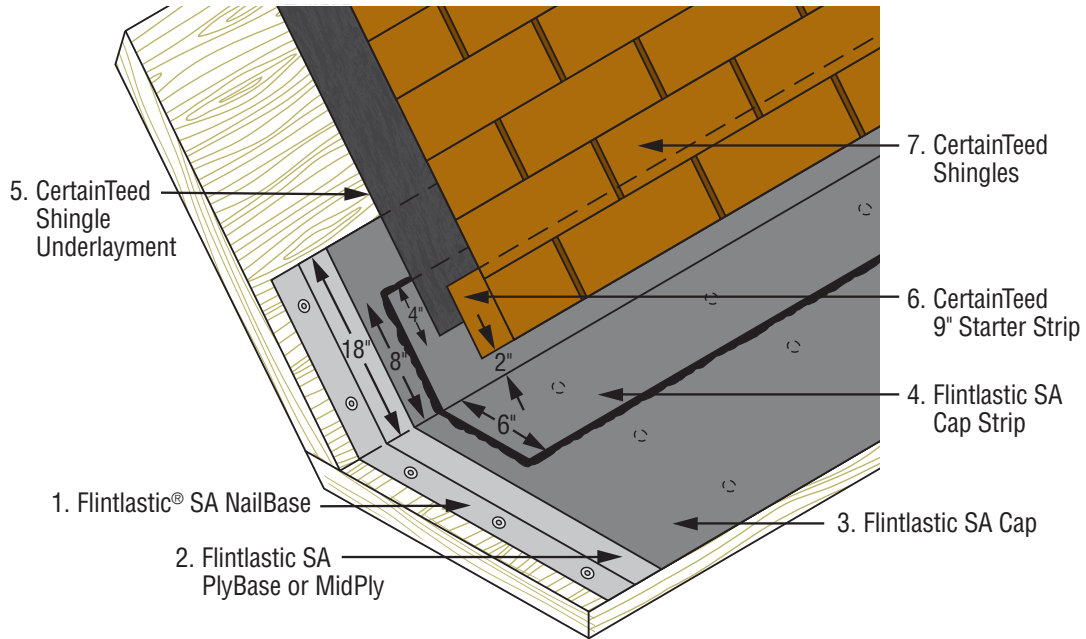

CT-24 Mansard Roof Transition Flashing

CertainTeed Low-Slope Roof Systems



SmartFlash® ONE



FlintBoard®



FlintEDGE®

For more information on CertainTeed Commercial Roofing Products, go to www.certainteed.com.

CertainTeed Flintlastic roofing products are intended for use by professional roofing contractors only. It is the responsibility of the installer to follow all appropriate and required safety precautions in conjunction with the installation of any CertainTeed roofing product.

Meets or exceeds ASTM D6164 (SA MidPly and SA Cap), ASTM D6163 (SA Cap FR) and ASTM D4601 (SA NailBase and PlyBase).



UL 2218 Class 4 Impact Resistance – Certain systems are UL classified as to impact resistance as described in the UL Roofing Materials and Systems Directory.



ICC-ES ESR-1388



CertainTeed

Ceilings • Gypsum • Insulation • Roofing • Siding • Trim

20 Moores Road, Malvern, PA 19355 | 800-233-8990 | certainteed.com

©06/25 CertainTeed, Printed in the USA, Code No. 00-00-907-NA-EN