

Design & Specifications

Use of the Product

Gyptone BIG Curve is a unique solution for combining design and acoustic performance. Gyptone BIG Curve is a curved ceiling built on a metal grid system and doesn't have any visible joints. The curved ceiling can be used in many different segments, such as, office buildings, healthcare facilities, lobbies and so on. The 6.5mm (approx. 1/4") Curve gypsum board is fully recyclable.

Size Availability

Available in 1200 x 2400 x 6.5mm (approx. ≈47.25" x 94.5" x 1/4").

Surfaces

The panel comes in three perforation pattern options. Line 6, Quattro 41 and Sixto 63. The gypsum surface is intended to be painted after installation. Paint application must be made with a short nap roller (1/4" recommended). Do not spray paint panels as it will substantially impair the acoustic performance. Joints should be taped, finished, and sanded. See page 3 for additional information.

Attachment

Gyptone BIG Curve is built on a radius track ceiling consisting of a minimum of 1-3/4" screw surface for adequate attachment.

Fire

ASTM E 1264 Classification: Type G, Form G1, Pattern A G.

Load

Maximum point load is 2.2lbs. If higher loading is needed, the elements should be independently suspended from the structure.

Stability

Gyptone BIG is to be installed and used in rooms with relative humidity not exceeding 70% or temperatures exceeding 104° F. Gyptone BIG Curve can be curved (dry) to a maximum 10-foot and curved (wet) to a maximum 5-foot radius.

Weight

1.32lbs./sq. ft (6.5 kg/m²).

Cleaning

The panels can be cleaned with a damp cloth depending on the final surface treatment. The use of mild detergent is recommended.

Maintenance

Individual panels can be replaced. Repainting should be done with a short nap roller. Panels must not be spray painted. Panels should be installed in climate-controlled conditions.

Safety and Handling

When cutting product, eye protection and ear protection is recommended.

Installation for Gyptone® BIG™ Curve

Read the entire manual before installing.

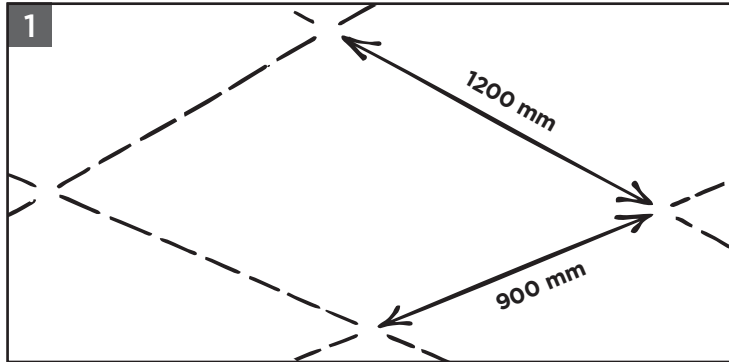

Plan out where to place the hangers. Fix the hangers using appropriate fasteners. Hanger center distance = 900 mm. Main channel center distance = 1200 mm.

The first hanger should be placed with a maximum distance of no more than 200 mm from the wall. The center distance for the main channels are 1200 mm. The first main channel should be placed no more than 120 mm from the wall.

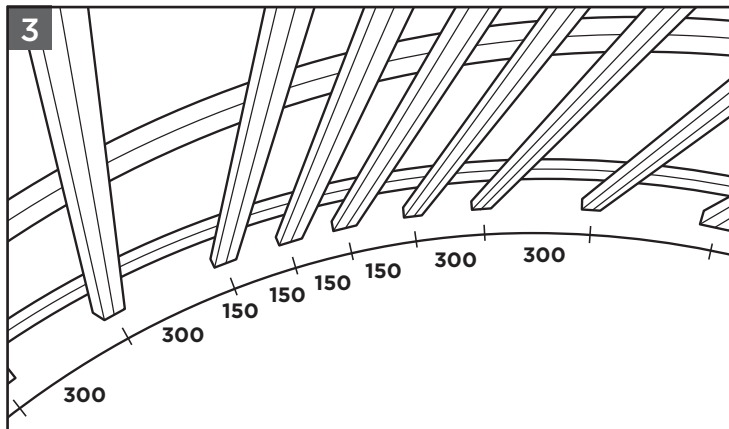
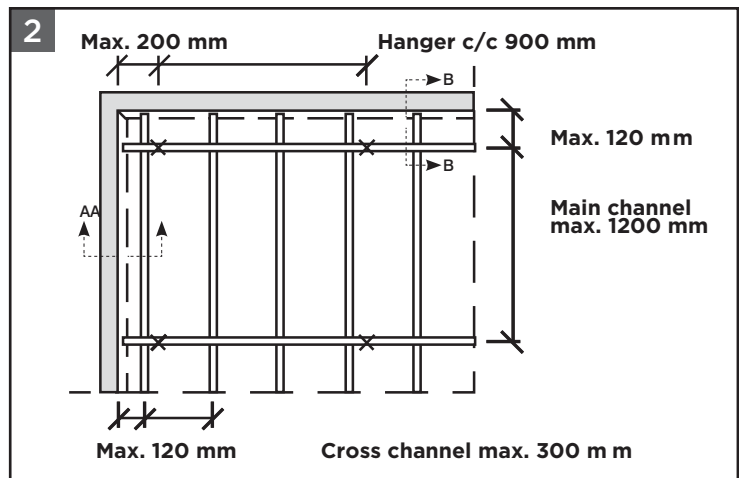

Where there is a connection between the short edges of the BIG Curve, it is important to place the cross channels with a center distance of 150 mm to secure a smooth curved transition between the BIG Curve boards.

Installation for Gyptone® BIG™ Curve

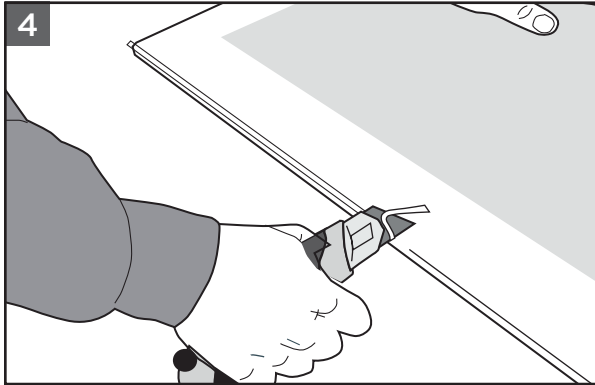

BIG Curve has only tapered edges on the long sides. On the short sides, it is important to make a bevelled edge with a knife so more filler can be applied in the connections between the boards.

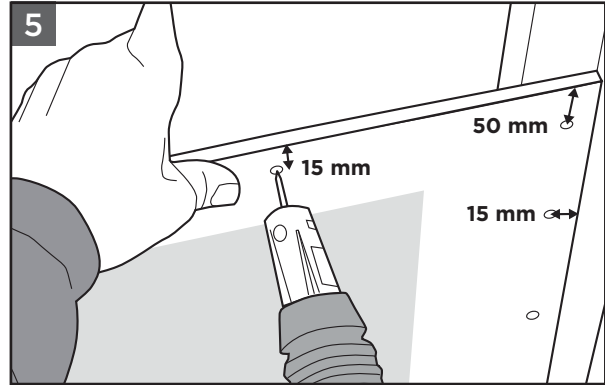

The board must be fixed to the steel system with special Gyptone QSC25 screws. All short edges must be supported by the steel system.



Installation of the boards on the grid system must be done with an even amount of pressure applied slowly to the boards. Place the screws according to the fixing template on page 4. The board must be curved along its length.

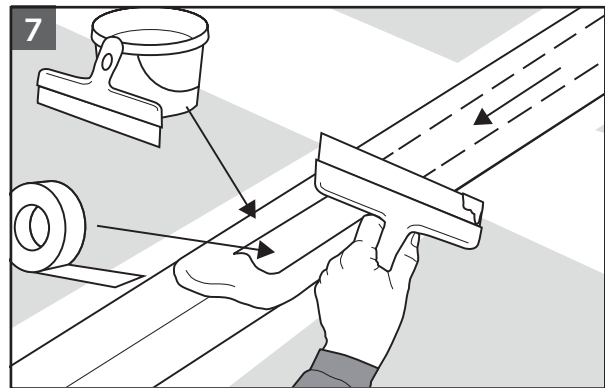

Fill all joints with an appropriate filler along with a paper strip. When the filler is dry, use sandpaper and make a smooth surface between the boards. Do not overlap the paper strips.

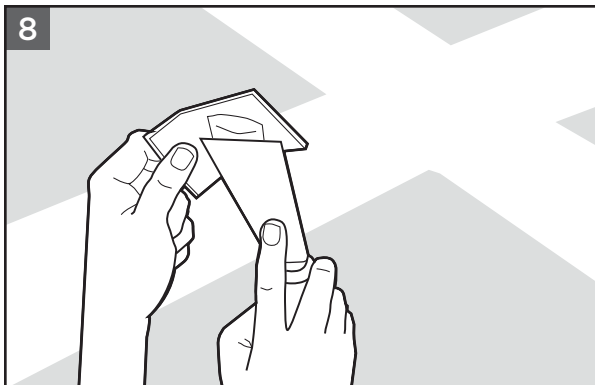

To cover the screws, use appropriate filler. Keep using filler and sandpaper until surface of the board is smooth.

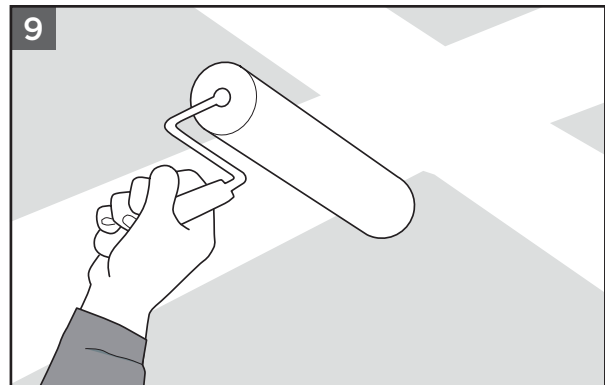

Paint the BIG Curve with a short napped roller. Prime the panel first and then paint twice. Avoid paint in the perforation. Do NOT spray paint BIG Curve, because of the risk of getting paint on the acoustic tissue. Any paint applied to acoustic tissue backing will strongly reduce the acoustic performance.

Installation for Gyptone® BIG™ Curve

Gyptone BIG Curve boards.

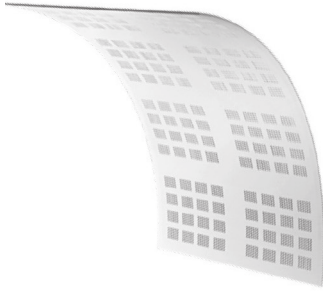

Gyptone BIG Curve
Line 6 

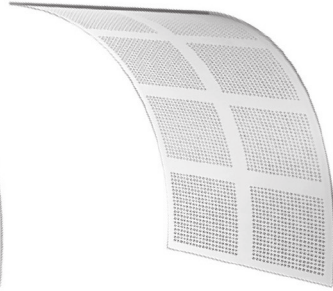

Gyptone BIG Curve
Quattro 41 

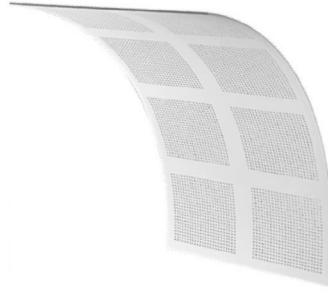

Gyptone BIG Curve
Sixto 63 

Fixing template

Main channels o.c. 1200mm (48") and cross channels o.c. 300mm (12")
(cross channels o.c. 150mm (6") at the short edges).

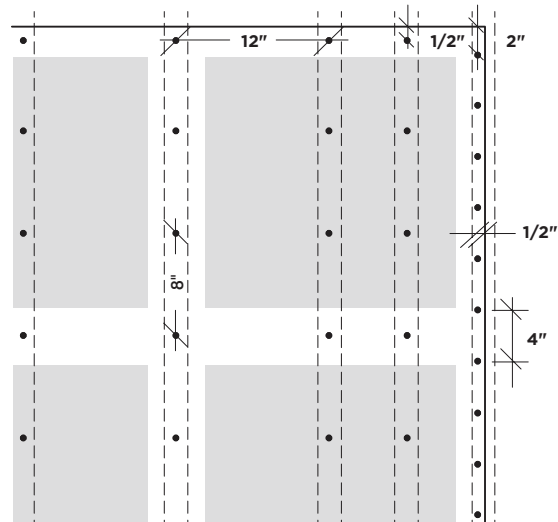
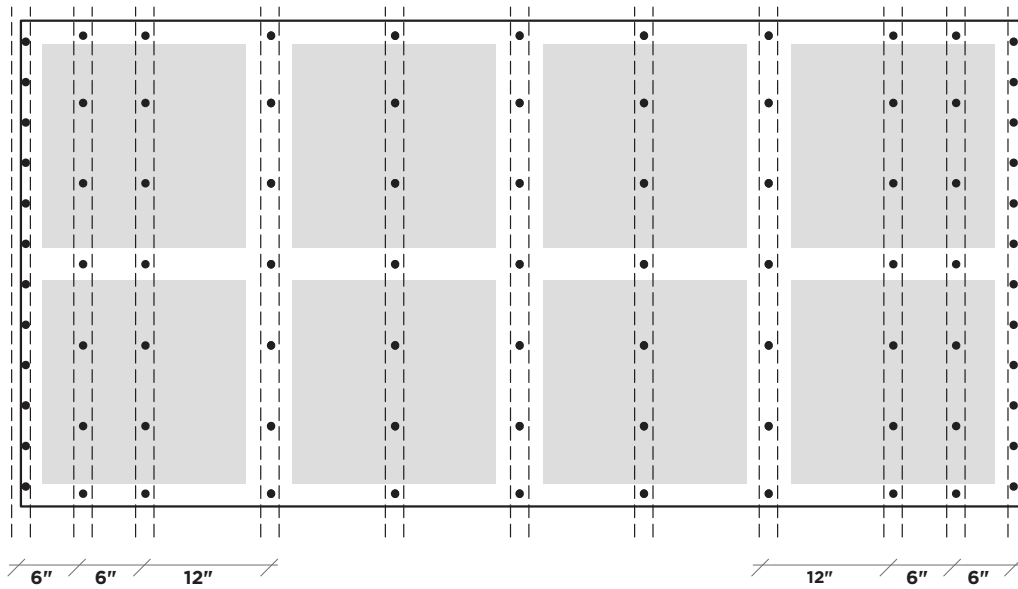

Gyptone BIG Curve boards, wet curving.

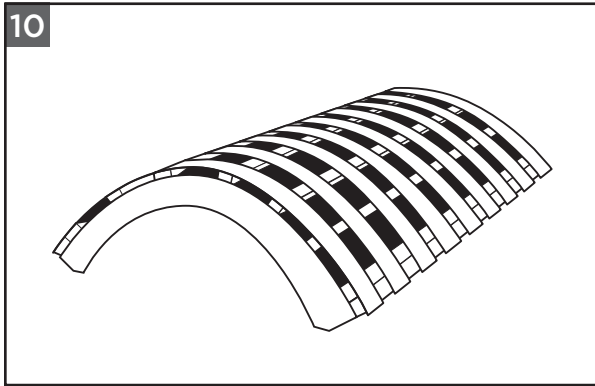

Build a template to curve the wet Gyptone, in the specific curved radius - Radius from 9ft-5ft use wet bending.

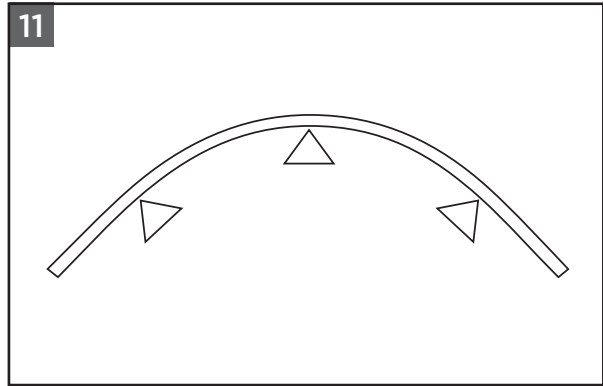

Use clean water to bend the panel. Water must be applied on the side of the Gyptone board close to the center of the radius.

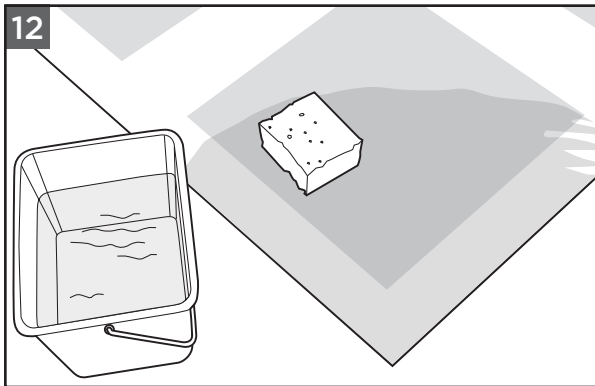

Place the panel on an even floor or table. Apply a small amount of water with a sponge to the panel. If needed, apply more water after 2-5 minutes (continue to apply water for 15-20 minutes in total). Avoid water inside of the perforation.

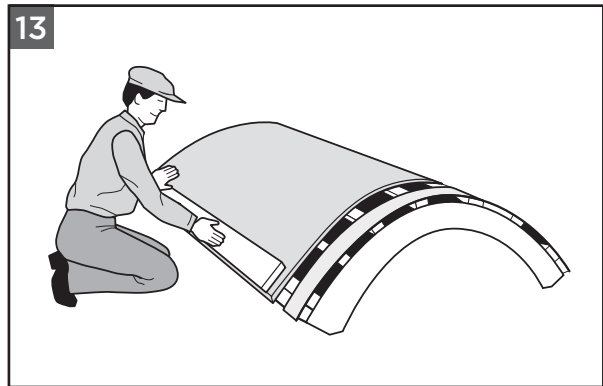

Carefully lift the wet panel and place it on top of the template. Apply pressure on the edges with a flat, wooden plank or steel stud and fix the stud with a clamp until the gypsum board is 100% dry.

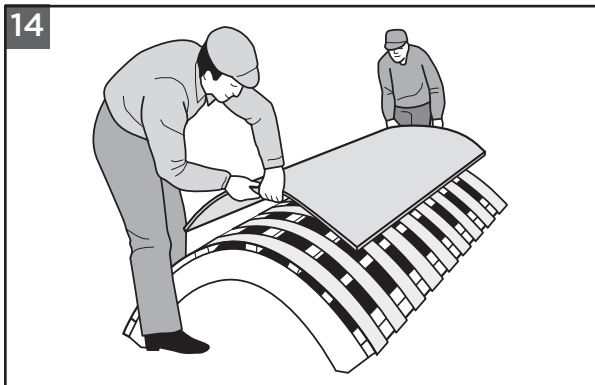

Carefully lift up the panel when it is 100% dry and install no more than 2 hours after it is removed from the form.

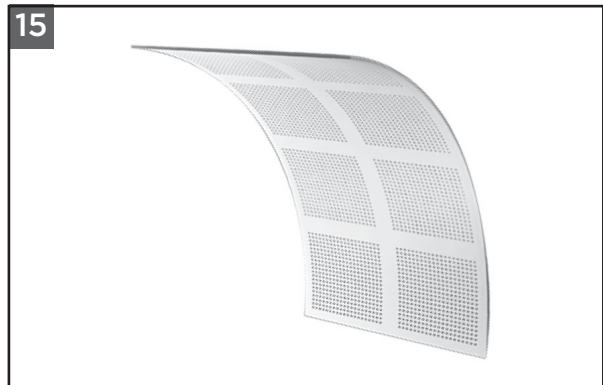

Note: The board must be curved length-wise.

Gyptone BIG Curve boards, good advice.

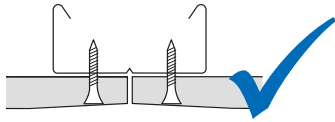

Suspension system

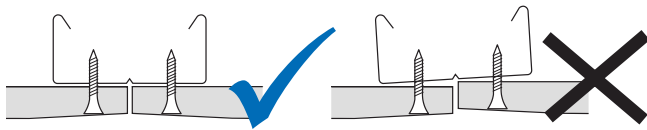

A 100% smooth surface

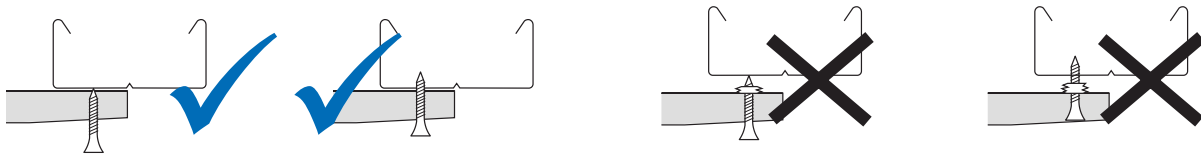

Full contact between board and grid before screwing

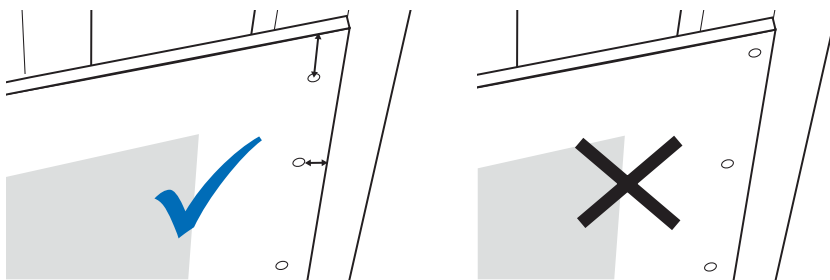

Screw positioning

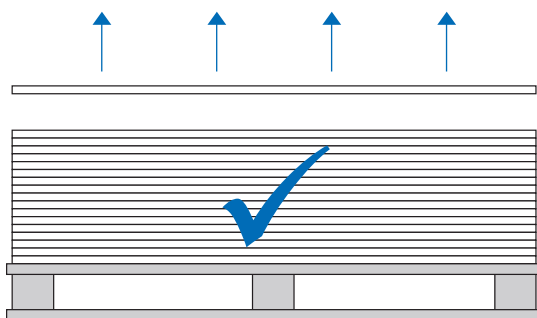

BIG Curve must be lifted from the stack

If the board is pulled off the stack, the acoustic tissue on the backside might get rolled of the board. This might give some issues with the level between boards during the installation.

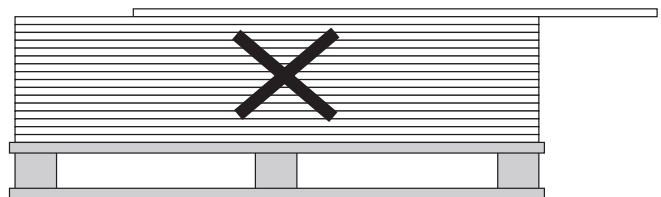

Installation for Gyptone® BIG™ Curve

Checklist for installing Gyptone BIG Curve.

- Humidity must not exceed 70% during construction or when the room is in use.
- Measure the room and lay out hangers properly, based off the dimensions of the space.
- Place an extra cross channel with a center distance of 150 mm on each short side of a board in order to make a smoother curve.
- Make a small, beveled edge on the short side of the board to obtain a smoother joint when applying filler.
- Never place a screw in a corner of a board.
- Place screws with a center distance of 100 mm, on the short sides of the board.
- Never dry bend a BIG Curve, to less than a radius of 9 feet.
- Always prime the surface of the boards, before painting it twice.
- Read this installation manual before commencing the work.