

GlasRoc[®] and M2Tech[®] Shaftliner For Shaftwalls

Dependability When it Matters Most



The walls you build are constructed with precision and hard work. The products you use need to bring that same level of performance. That's why we offer a full range of reliable drywall and finishing solutions that make installations faster and simpler, all while helping you keep pace with demand - no matter the size, complexity, or location of the project.

Our drywall solutions are manufactured with quality and consistency, and our products are readily available, no matter where you are in the country. Plus, our in-house technical support team is at the ready to help you through even the most demanding installations. We have your back, so you can easily stay on schedule, within budget, and keep your projects running smoothly.

BIM/CAD INFORMATION

The BIM and CAD UL fire rated assemblies and sound assemblies can be found on CertainTeed's BIM and CAD Design Studio at bimlibrary.saint-gobain.com.

CertainTeed's BIM and CAD Design Studio provides BIM and CAD details to many UL fire rated assemblies and sound assemblies in an easy to view experience. Plus, downloadable Revit and DWG and PDF CAD Details are available.

SUSTAINABILITY

Can contribute to the U.S. Green Building Council's LEED Credit Qualification in several credit categories to assist in obtaining LEED certification. Sustainable documentation, including recycled content, EPD's, HPD's, VOC Certifications, can be found at saintgobain.ecomedes.com.



The GlasRoc® and M2Tech® Shaftliner advantage

GlasRoc® and M2Tech® Shaftliner are specially formulated Type X products for applications where enhanced mold resistance is preferred. They can be used for firewalls in standard multi-family residential applications.

GlasRoc® SHAFTLINER

GlasRoc® Shaftliner is a paperless mold and moisture resistant gypsum panel combining reinforcing glass mats and a specially formulated fire and moisture resistive, non-combustible core. GlasRoc® Shaftliner provides:

- Long term protection (12 months) to weather exposure.
- A superior water resistant surface that does not inhibit water vapor permeance.
- Excellent Type X fire resistance properties, and numerous fire rated designs.
- Achieves score of 10 for mold resistance per ASTM D3273.

M2TECH®

M2Tech® gypsum panels feature M2Tech® moisture and mold resistant technology. M2Tech® gypsum panels provide:

- Additional zone of protection against moisture and mold
- Numerous Type X fire-rated assembly designs for safety and performance
- Easy to cut and install. Does not require special tools
- May be finished, painted, or wallpapered using conventional gypsum panel techniques
- Achieves score of 10 for mold resistance per ASTM D3273

GlasRoc® and M2Tech® Shaftliner, and CertainTeed's gypsum panels that include M2Tech® technology, can be combined to offer superior mold resistance performance for Shaftwalls.

Gypsum Shaftwall systems are IBC and NBCC code approved and replace traditional masonry for shaftwall systems. Some inherent advantages of gypsum Shaftwalls are: lighter weight, reduced thickness, ease and speed of installation,

no requirement for scaffolding, and no requirement for an additional trade on the job.

Shaftwalls offer the advantages of fire resistance and noise attenuation. These walls offer fire resistance rating line of 1 – 4 hours between units and provide sound ratings up to STC 59 when SilentFX® QuickCut™ Type X is used in certain Shaftwall configurations.

GLASROC® SHAFTLINER

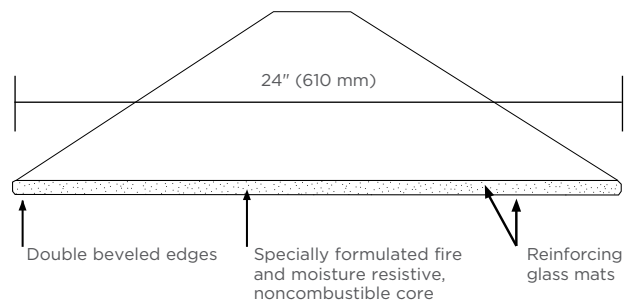

M2TECH® SHAFTLINER

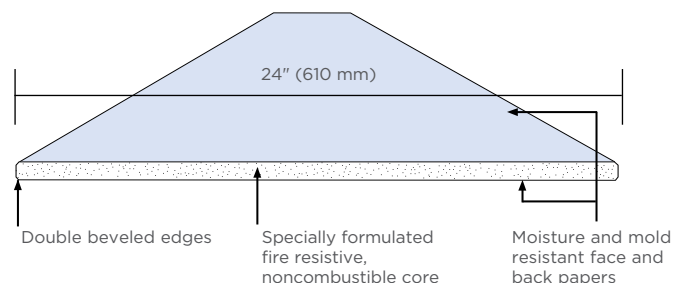

GlasRoc® and M2Tech® Shaftliner are designed and engineered for use in construction of lightweight Shaftwall and Firewalls. These systems are UL, cUL, and ULC listed for fire resistance. GlasRoc® and M2Tech® Shaftliner can be substituted with each other.

GlasRoc® and M2Tech® Shaftliner are 1" (25 mm) thick gypsum panels with a specially formulated, Type X, fire resistive, noncombustible core. Double beveled edges make installation easier.

M2Tech® Shaftliner is enclosed in a moisture and mold resistant, blue-grey tinted, 100% recycled paper.

GlasRoc® Shaftliner has reinforced glass mats. When tested for mold resistance by an independent lab at the time of manufacturing, GlasRoc® and M2Tech® Shaftliner achieved the highest possible score of 10 per ASTM D3273, "Standard Test Method for Resistance to Growth of Mold on the Surface of Interior Coatings in an Environmental Chamber".

GlasRoc® and M2Tech® Shaftwall Systems

1 to 4 Hour Fire Resistance Ratings

The walls of elevator shafts and stairwells are a vital life safety link in multi-story buildings. These walls are the main line of defense against fire entering the cavities behind them and spreading rapidly from floor to floor.

Gypsum shaftwall systems have replaced traditional masonry for interior vertical enclosures including mechanical enclosures, stairwells, elevator enclosures, and other mechanical chases. Some inherent advantages of gypsum shaftwall systems are: lightweight construction, thinner walls, ease and speed of installation and clean up, cost-effective construction.

Shaftwall Systems provide one to four hour fire resistance ratings in non-loadbearing configurations and moisture and mold resistance during construction.

The systems are designed to withstand the intermittent surges of air pressure caused by fast moving elevator cabs. These systems utilize either an I-Stud, C-H Stud or C-T Stud and J-Track to support layers of 1" (25 mm) GlasRoc® or M2Tech® Shaftliner Type X and either 1/2" (12.7 mm) CertainTeed Type C, 5/8" (15.9 mm) CertainTeed Type X, CertainTeed Type C, CertainTeed

M2Tech® Type X or CertainTeed SilentFX® QuickCut™ Type X gypsum panels.

EITHER I-Stud, C-H Stud or C-T Studs **MAY BE USED IN CONJUNCTION WITH GlasRoc® or M2Tech® shaftwall systems.** All of the components are noncombustible.

Shaftwalls can be erected from one side, eliminating the need to build extensive scaffolding.

GlasRoc® and M2Tech® Shaftwall assemblies save money in several ways. With less weight per square area than other shaft enclosures, structural framing requirements are reduced; as is the need for heavily reinforced footings. The 24" (610 mm) wide GlasRoc® and M2Tech® Shaftliner slide quickly into the I-Stud, C-H Stud or C-T Stud and automatically provides 24" (610 mm) o.c. spacing. Shaftwalls can be erected from one side, eliminating the need to build extensive scaffolding. No finishing is required on the shaft side of the partition.

1. All construction shall comply with local building codes.
2. Only those components specified shall be used when constructing any fire or

sound rated system. Substitutions may adversely affect performance capabilities.

3. Unless otherwise specified in the system design, face layer joints of 1/2" (12.7 mm) CertainTeed Type C, 5/8" (15.9 mm) CertainTeed Type X, CertainTeed M2Tech® Type X, CertainTeed Type C or CertainTeed SilentFX® QuickCut™ Type X gypsum panels shall be taped and finished with joint compound as described in "Surface Preparation" section.

FIRE RESISTANCE RATED DESIGNS

Vertical Shaftwalls

UL/cUL U417, U428, U429, U469, U505, U529, V470, W409, W437, W453, W471, ULC W446

Horizontal Shaftwalls

UL/cUL I515

For further technical information regarding sound control and fire resistance for Shaftwall Systems contact Gypsum Technical Services at 1-800-446-5284.



2-Hour Vertical Shaftwall System

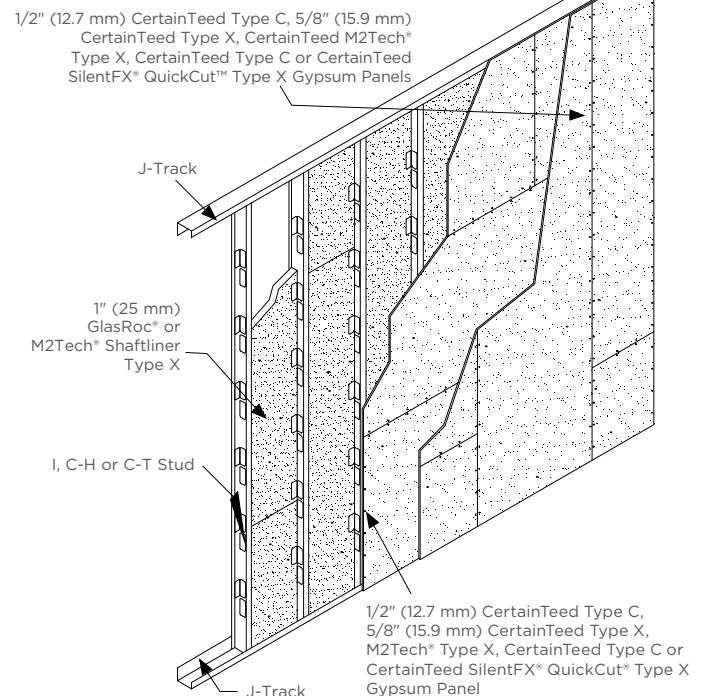

Working with the Product

FRAMING AND INSTALLATION

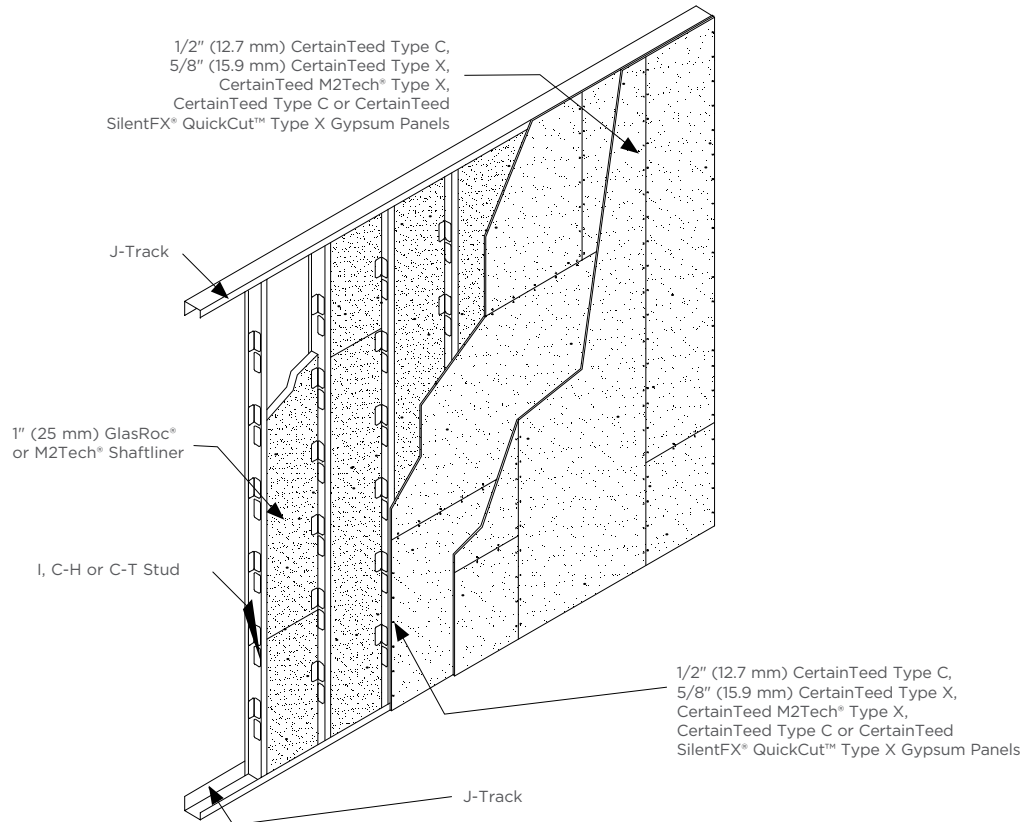

CUTTING

The score and snap method is a fast and efficient way to cut GlasRoc® and M2Tech® gypsum panels.

Steps:

1. On the logo side, position a straight edge along the line of cut.
2. Score sheets with a knife or other suitable tool.
3. With a quick, firm motion, snap back away from the face.
4. The back can either be cut with a knife or separated by snapping the piece in the opposite direction.
5. Smooth all cut ends and edges to ensure tight joints.

To make cutouts, score around the perimeter on the face and back and tap out the waste piece from the face side. Cutouts can also be made with a drywall saw.

GlasRoc® and M2Tech® gypsum panels can also be cut with a saw. For information on avoiding dust inhalation, refer to the Safety Data Sheet available on our website, www.certainteed.ca. Safety glasses should always be worn when using power tools.

INSTALLATION

Steel Framing and Installation of GlasRoc® or M2Tech® Shaftliner gypsum panels.

1. Lay out per construction drawings.
2. Install J-Track along the floor and ceiling and vertically at columns or abutting partitions, positioning the long legs closest to the shaft. Secure each piece with the appropriate power driven fasteners spaced a maximum 24" (610 mm).
3. Pre plan stud layout 24" (610 mm) o.c. maximum so the terminal stud on either end will fall a minimum of 8" (200 mm) from the opening.
4. Install GlasRoc® or M2Tech® Shaftliner gypsum panels vertically. Cut panels a maximum of 1" (25 mm) less than floor to ceiling height. The leading edge of the first panel must be attached to the long leg of the vertical J-Track with 1-5/8" (41 mm) Type S screws spaced 12" (300 mm) o.c. or by tabs in the J-Track. Secure the top and bottom edges using the same fasteners and spacing or using the tabs.
5. Friction fit an I, C-H or C-T Stud into the top and bottom tracks and slide it snugly against the GlasRoc® or M2Tech® Shaftliner gypsum panels. Make sure the edge of the

6. panel is in full contact with the center web of the stud and covered by all of the tabs.
6. Erect adjacent GlasRoc® or M2Tech® Shaftliner gypsum panels by inserting in the top and bottom J-Track and between the tabs and flange on the opposite side of the I, C-H or C-T Studs to complete framing. Check periodically to ensure they are plumb. Screws are not required for the top and bottom J-Tracks.
7. For doors, ducts or other openings install J-Track as perimeter framing.
8. For walls exceeding 12' (3660 mm) in height, GlasRoc® or M2Tech® Shaftliner gypsum panels may be butted to span the floor-ceiling height. The shorter panel should be at least 24" (610 mm) long or of sufficient length to engage at least two I, C-H or C-T Stud tabs on each panel edge. End joints should fall alternately in the upper and lower 1/3 height of the partition. Subsequent butt joints between adjoining panels should be spaced no closer than 24" (610 mm) in elevation. Joints may be butted together or use a I, C-H or C-T Stud placed horizontally between panels to secure each joint.
9. As an option, if required in building code jurisdictions, butt joints in GlasRoc® or M2Tech® Shaftliner gypsum panels may be

Working with the Product

back blocked in the cavity by screw attaching a 12" x 24" (300 mm x 610 mm) piece of 5/8" (15.9 mm) CertainTeed Type X, M2Tech® Type X or 1" (25 mm) GlasRoc® or M2Tech® Shaftliner gypsum panel over the joint to the tabs of the I, C-H or C-T Studs.

10. Frame all cut openings in the shaft side with J-Track, providing adequate structural support for openings over 48" (1220 mm).
11. Elevator door frames must be tied to shaftwall enclosures; however, they must remain independently supported by the building frame. Attach GlasRoc® or M2Tech® Shaftwall System to elevator door frame jamb and anchor clips with pan head screws. The J-Track 3" (76 mm) leg is used at the intersection of the elevator door frame and shaftwall system.
12. Where required, use an acoustical sealant to caulk (Green Glue or CertainTeed SilentFX®) around the perimeter of wall sections, door frames, call boxes and any other openings that may allow air passage.

1-Hour-Rated System: Finished One Side

1. Apply a single layer of 5/8" (15.9 mm) CertainTeed Type X, CertainTeed M2Tech® Type X or CertainTeed Type C gypsum panel vertically with 1" (25 mm) Type S screws.
2. Holding the gypsum panel firmly against the framing, begin fastening in the center of each sheet and move outward toward ends and edges.
3. Space screws at 12" (300 mm) o.c. in the field of the panel and 8" (200 mm) o.c. around the perimeter.
4. Set fastener heads slightly below the surface without breaking the face paper or damaging the gypsum core.

2-Hour-Rated System: Finished One Side

1. Install a base layer of 1/2" (12.7 mm) CertainTeed Type C, 5/8" (15.9 mm) CertainTeed Type X, CertainTeed M2Tech® Type X, CertainTeed Type C or CertainTeed SilentFX® QuickCut™ Type X gypsum panels vertically or horizontally with 1" (25 mm) Type S buglehead screws at 24" (610 mm) o.c.
2. Apply a face layer of 1/2" (12.7 mm) CertainTeed Type C, 5/8" (15.9 mm) CertainTeed Type X, CertainTeed M2Tech® Type X, CertainTeed Type C or CertainTeed SilentFX® QuickCut™ Type X gypsum panel vertically or horizontally (opposite of base layer) over the face layer with 1-5/8" (41 mm) Type S screws spaced at 24" (610 mm) o.c.
3. All joints in the face layer must be staggered with respect to those in the base layer.

2-Hour-Rated System: Finished Two Sides

1. Follow the preceding framing details using I, C-H or C-T Studs and J-Track.
2. Apply GlasRoc® or M2Tech® Shaftliner gypsum panel, followed by the

attachment of 1/2" (12.7 mm) CertainTeed Type C, 5/8" (15.9 mm) CertainTeed Type X, CertainTeed M2Tech® Type X, CertainTeed Type C or CertainTeed SilentFX® QuickCut™ Type X gypsum panel in a single facing layer on each side of the studs vertically, parallel to framing, with 1" (25 mm) No. 6 Type S screws 12" (300 mm) on center.

2-Hour-Rated System: Sound Control (STC) Rating of 55

A two-hour-rated shaftwall partition can be configured to achieve a minimum STC rating of 50 with the following system.

1. Fill wall cavity with 1-1/2" (38 mm) CertainTeed Fiber Glass Insulation, or equivalent.
2. Apply a base layer of 5/8" (15.9 mm) SilentFX® QuickCut™ Type X and a face layer of 5/8" (15.9 mm) CertainTeed Type X or CertainTeed M2Tech® Type X gypsum panel. Attach the base layer of SilentFX® QuickCut™ Type X using 1" (25 mm) Type S buglehead drywall screws spaced 24" (610 mm) o.c. along the edges and in the field of the board with the first screw 3" (75 mm) from board end. Attach the face layer of CertainTeed Type X or CertainTeed M2Tech® Type X using 1-5/8" (41 mm) No. 6 Type S buglehead screws spaced 12" (300 mm) o.c. along the edges and in the field with the first screw 6" (152 mm) from board end.
3. Apply caulk, such as Green Glue Noiseproofing Sealant, under the top and bottom tracks and around the exterior face perimeters of each layer of 5/8" (15.9 mm) CertainTeed SilentFX® QuickCut™ Type X or CertainTeed M2Tech® Type X gypsum panel.

3-4-Hour-Rated System:

For 3 and 4 hour assemblies, please refer to drawing descriptions.

Surface Preparation of Finished Sides:

No finishing is required on the shaft side of partitions. Joints, corners and fastener heads on the opposite face side shall be finished in accordance with ASTM C840, the GA-216, the Fire Resistance Design Manual GA-600 and CertainTeed Finishing systems, or equivalent joint compound manufacturer's instructions. Joint compound shall comply with ASTM C475.

1. No surface treatment shall be done until the interior temperature has been maintained at a minimum of 50°F (10°C) for at least 48 hours prior to application of compounds and until all materials have completely dried. Adequate continuous ventilation must also be provided.
2. Embed tape into the wet compound and allow to dry. For inside corners, crease the tape and work it into the joint.
3. Apply a second coat of compound across the joint and feather to approximately 4" (100 mm) on each side.
4. Apply a third coat and feather to approximately 6" (152 mm) on each side

5. Allow each coat to dry before proceeding.
6. Attach corner bead to outside corners and apply three coats of joint compound. Feather out each coat as described in steps 3-5.
7. Spot cover all fastener heads with three coats of joint compound applied in different directions.
8. Additional coats of compound may be required to achieve higher Levels of Finish.
9. Lightly sand the last coat of all treated areas, taking care not to roughen the surrounding gypsum panel paper. Smoothing can also be accomplished with a damp sponge.

Finishing:

1/2" (12.7 mm) CertainTeed Type C, 5/8" (15.9 mm) CertainTeed Type X, CertainTeed M2Tech® Type X, CertainTeed Type C or CertainTeed SilentFX® QuickCut™ Type X gypsum panels can be finished with paint, texture or wallpaper. High quality primer/sealer must be used prior to any type of final decoration. For high gloss paint and severe lighting conditions, a thin skim coat of joint compound or CertainTeed Level V Wall/Ceiling Primer Surfacer, should be applied across the entire surface (Level 5 Finish). This will help minimize the irregularities and porosity differences between the materials. Refer to GA-214, GA-216, and ASTM C840 for additional finishing instructions. Finishing is not required on shaft side of wall system.

LIMITATIONS

- GlasRoc® or M2Tech® Shaftwall Systems are for non-loadbearing partitions and ceilings only.
- GlasRoc® or M2Tech® Shaftwall Systems shall not be exposed to sustained temperatures exceeding 125°F (52°C).
- GlasRoc® or M2Tech® gypsum panel should not come in direct contact with concrete, masonry or other surfaces that have a high moisture content.
- GlasRoc® or M2Tech® Shaftwall Systems are not designed to serve as an unlined air supply duct. Where gypsum panel is used in air handling systems, the panel temperature shall be maintained above the air stream dew point temperature but not higher than 125°F (52°C).
- Caulk with Green Glue or Noiseproofing Sealant, or equivalent to seal perimeters and penetrations to minimize air noises and dust associated with air movement.

Working with the Product

HELPFUL HINTS

1. Use a fastening plate to secure the J-Track whenever fasteners are closer than 4" (100 mm) to the edge. Setting the plate at the time of concrete construction will avoid spalling by mechanical fasteners.
2. Pre-cut I, C-H or C-T Studs 5/8" (15.9 mm) less than the height of the opening.
3. Pre-cut 1" (25 mm) GlasRoc® or M2Tech® Shaftliner panels 1" (25 mm) less than the height of the opening.
4. In structural steel frame construction, install J-Track sections before applying spray-on fireproofing.
5. Items to be anchored to the wall (cabinets, sinks, handrails, etc.) should be fastened to the I, C-H or C-T Studs or to plates secured behind or between the layers of CertainTeed Type X, CertainTeed M2Tech® Type X, CertainTeed Type C or SilentFX® QuickCut™ Type X.

6. Joint compounds should be applied at ambient temperatures above 50°F (10°C). Provide adequate ventilation to "drive-off" excess moisture.
7. For acoustic sealant and prevention of air leakage, use a bead of flexible caulking, such as Green Glue Noiseproofing Sealant, at the perimeter of each wall under the face layer and under the 2-1/2" (64 mm) flange of J-Track for shaftwall finished on one side to minimize whistling and dirt accumulation.
8. Use Type S screws for 25 ga. (0.018" [0.46 mm]) steel framing. Use Type S-12 screws for 20 ga. (0.033" [0.84 mm]) or heavier steel framing.

- ULC W446
- Gypsum Association Publications GA-214, GA-216, and GA-600
- ASTM C475, C514, C645, C734, C840, C1002, C1047, C1396, C1658, E84, E119,
- CAN/ULC-S101, CAN/ULC-S102, CAN/ULC-S114
- NBCC
- CAN/ULC S702.1

TECHNICAL REFERENCES

For additional information on application and finishing consult:

- ICC International Codes
- UL/cUL U417, U428, U429, U469, U505, U529, V470, W409, W437, W453, W471, I515

HANDLING AND STORAGE

GlasRoc®, CertainTeed, M2Tech®, and SilentFX® QuickCut™ gypsum panels should be stacked flat on a smooth, level surface, not directly on the ground. When spacers are used, position them closely enough together to minimize warpage. Care should be taken to prevent damage to edges and corners. Always keep GlasRoc®, CertainTeed, M2Tech®, and SilentFX® QuickCut™ gypsum panels dry prior to installation. CertainTeed assumes no responsibility for consequential damages that may result from the presence of standing water.

PRODUCT SPECIFICATIONS

	Type X	M2Tech® Type X	Type C		SilentFX® QuickCut™ Type X	GlasRoc® or M2Tech® Shaftliner
Standards	ASTM C1396	ASTM C1396	ASTM C1396	ASTM C1396	ASTM C1766, ASTM C1396	ASTM C1396, ASTM C1658
Thickness	5/8" (15.9 mm)	5/8" (15.9 mm)	1/2" (12.7 mm)	5/8" (15.9 mm)	5/8" (15.9 mm)	1" (25 mm)
Width/Size	4' (1220 mm)	4' (1220 mm)	4' (1220 mm)	4' (1220 mm)	4' (1220 mm)	24" (610 mm)
Approx. Weight	2.2 psf (10.7 kg/m ²)	2.2 psf (10.7 kg/m ²)	1.9 psf (9.3 kg/m ²)	2.3 psf (11.2 kg/m ²)	2.8 psf (13.7 kg/m ²)	GlasRoc Shaftliner 4.0 psf (19.5 kg/m ²) M2Tech Shaftliner 3.7 psf (18 kg/m ²)
Edges	Tapered	Tapered	Tapered		Tapered	Double Beveled

CertainTeed Gypsum certifies that the gypsum panel products described herein meet or exceed listed ASTM standard specifications. All products are not available in all geographic areas. Consult local building codes for regulations in your area. For further information, consult a CertainTeed sales representative.

Steel Framing	
C645	C645
25 ga*	20 ga**
2-1/2" (64 mm), 4" (102 mm)	2-1/2" (64 mm), 4" (102 mm), 6" (152 mm)

* .018" (18 mils [0.46 mm])

** .0329" (33 mils [0.84 mm])

SURFACE BURNING

	Type X	M2Tech® Type X	Type C	SilentFX® QuickCut™ Type X	GlasRoc® or M2Tech® Shaftliner
ASTM E84 Flame Spread/Smoke Developed	15/0 Class A	15/0 Class A	15/0 Class A	0/0 Class A	GlasRoc Shaftliner 0/0 Class A M2Tech Shaftliner 15/0 Class A
CAN/ULC-S102 Flame Spread/Smoke Developed	0/0	0/0	0/0	0/5	0/0

Vertical Systems

1 and 2 Hour Fire Resistance Ratings

FIRE RESISTANCE RATED SYSTEM DESIGNS FINISHED ONE SIDE

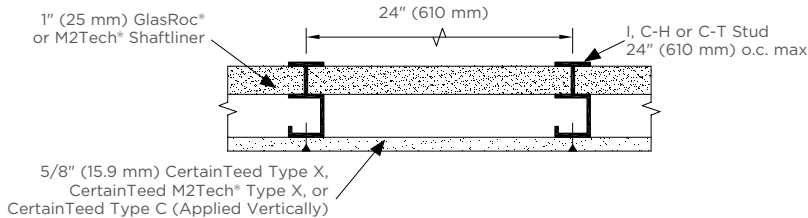

1" (25 mm) GlasRoc® or M2Tech® Shaftliner gypsum panels are inserted between 2-1/2" (64 mm), 4" (102 mm) or 6" (152 mm) I, C-H, or C-T Studs. A single layer of 5/8" (15.9 mm) CertainTeed Type X, CertainTeed M2Tech® Type X or CertainTeed Type C gypsum panels are applied vertically, parallel to framing, on open stud-face side with 1" (25 mm) Type S screws spaced 12" (300 mm) on center. Exposed joints and screwheads are to be finished with CertainTeed Finishing System unless otherwise specified. (Non-Loadbearing)

1 HR

VERTICAL SHAFTWALL SYSTEM

FINISHED ONE SIDE

FIRE TEST

UL U417/ULC W446

SOUND REPORT

NOAL 19-0705 STC 45 with 2-1/2" (63.5 mm) C-H studs, 5/8" (15.9 mm) CertainTeed Type X, and CertainTeed Fiber Glass Insulation; NOAL 17-1140 STC 49 with 2-1/2" (63.5 mm) C-T studs, 5/8" (15.9 mm) SilentFX QuickCut, and CertainTeed Fiber Glass Insulation or equivalent

APPROX. THICKNESS

3-1/8" (80 mm)

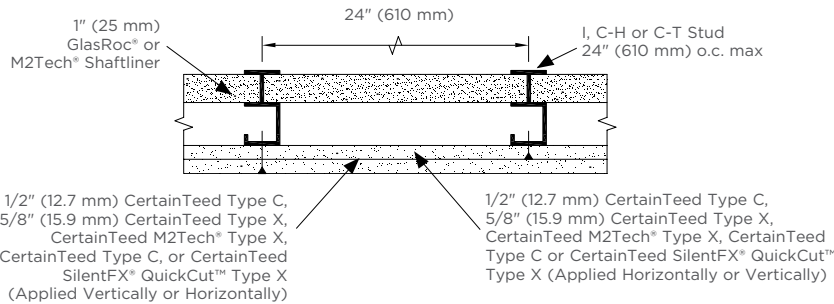

1" (25 mm) GlasRoc® or M2Tech® Shaftliner gypsum panels are inserted between 2-1/2" (64 mm), 4" (102 mm) or 6" (152 mm) I, C-H or C-T Studs. Two layers of 1/2" (12.7 mm) CertainTeed Type C, 5/8" (15.9 mm) CertainTeed Type X, CertainTeed M2Tech® Type X, CertainTeed Type C or CertainTeed SilentFX® QuickCut™ Type X gypsum panels are applied to one side, with the base layer applied vertically or horizontally to the open-stud-face of framing studs with 1" (25 mm) Type S buglehead screws spaced 24" (610 mm) o.c. The second layer is placed vertically or horizontally (opposite of base layer) over the base layer and fastened using 1-5/8" (41 mm) No. 6 Type S screws spaced 12" (300 mm) on center. Exposed joints and screwheads are to be finished with CertainTeed Finishing system, or equivalent, unless otherwise specified. (Non-Loadbearing)

2 HR

VERTICAL SHAFTWALL SYSTEM

FINISHED ONE SIDE

FIRE TEST

UL U417/ULC W446

SOUND REPORT

NOAL 18-0811 STC 53 with 2-1/2" (63.5 mm) C-T studs, 5/8" (15.9 mm) CertainTeed Type X or CertainTeed M2Tech® Type X, resilient channel and CertainTeed Fiber Glass Insulation or equivalent

APPROX. THICKNESS

3-3/4" (95 mm)

Vertical Systems

1 and 2 hour Fire Resistance Rating

FIRE RESISTANCE RATED SYSTEM DESIGNS FINISHED BOTH SIDES

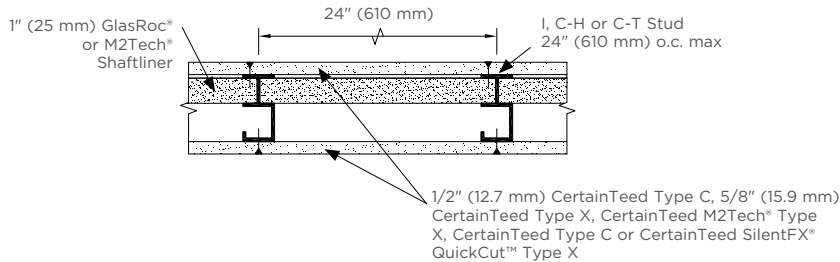

1" (25 mm) GlasRoc® or M2Tech® Shaftliner gypsum panels are inserted between 2-1/2" (64 mm), 4" (102 mm) or 6" (152 mm) I, C-H or C-T Studs. A single layer of 1/2" (12.7 mm) CertainTeed Type C, 5/8" (15.9 mm) CertainTeed Type X, CertainTeed M2Tech® Type X, CertainTeed Type C or CertainTeed SilentFX® QuickCut™ Type X gypsum panels are applied vertically on both sides, parallel to framing with 1" (25 mm) Type S screws spaced 12" (300 mm) o.c. Joints are staggered or offset. Exposed joints and screwheads are to be finished with CertainTeed Finishing System unless otherwise specified. (Non-Loadbearing)

2 HR

VERTICAL SHAFTWALL SYSTEM

FINISHED BOTH SIDES

FIRE TEST

UL U417/ULC W446

SOUND REPORT

NOAL 18-0810 STC 53 with 2-1/2" (63.5 mm) C-T studs, 5/8" CertainTeed Type X, resilient channel and CertainTeed Fiber Glass Insulation or equivalent

APPROX. THICKNESS

3-3/4" (95 mm)

SOUND CONTROL SYSTEM FINISHED ONE SIDE

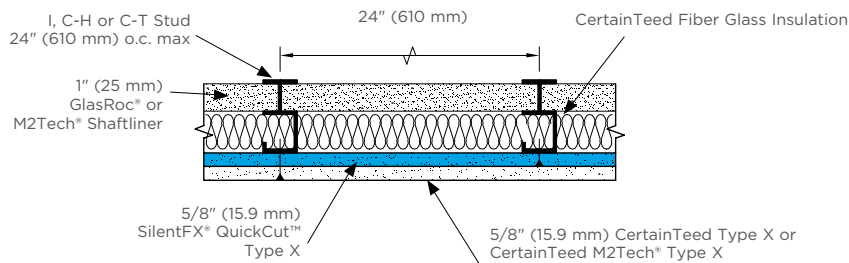

1" (25 mm) GlasRoc® or M2Tech® Shaftliner gypsum panels are inserted between 2-1/2" (64 mm) I, C-H or C-T Studs. Fasten the base layer of 5/8" (15.9 mm) SilentFX® QuickCut™ Type X horizontally or vertically to corridor side with 1" (25 mm) screws spaced 24" (610 mm) o.c. starting 3" (75 mm) from the top of each stud. Fasten face layer of 5/8" CertainTeed Type X or CertainTeed M2Tech® Type X gypsum panels opposite of base layer with 1-5/8" (41 mm) screws spaced 24" (610 mm) o.c. staggered 12" (300 mm) from base layer screws starting 6" (152 mm) from top of each stud. Screws are not required along top or bottom tracks. Joints must be offset. Tape and finish corridor joints with CertainTeed products. (Non-Loadbearing)

2 HR

VERTICAL SHAFTWALL SYSTEM

SOUND CONTROL

FINISHED ONE SIDE

FIRE TEST

UL/cUL U417

SOUND REPORT

NOAL 17-1141 STC 55 with CertainTeed Fiber Glass Insulation or equivalent

APPROX THICKNESS

3-3/4" (95 mm)

Vertical Systems

3 hour Fire Resistance Rating

FIRE RESISTANCE RATED SYSTEM DESIGNS FINISHED ONE SIDE

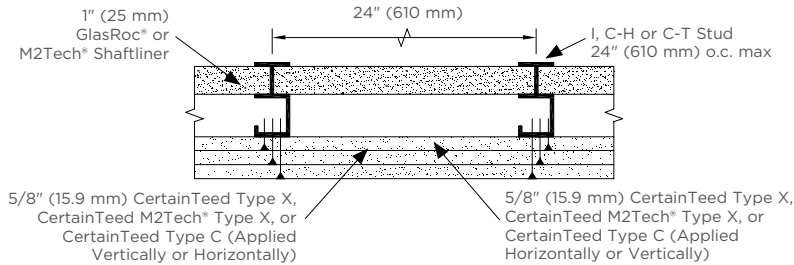

1" (25 mm) GlasRoc® or M2Tech® Shaftliner gypsum panels are inserted between 2-1/2" (64 mm), 4" (102 mm) or 6" (152 mm) I, C-H or C-T Studs. 5/8" (15.9 mm) CertainTeed Type X, CertainTeed M2Tech® Type X or CertainTeed Type C gypsum panels are applied to one side, with the base layer applied vertically or horizontally to the open-stud-face of framing studs with 1" (25 mm) Type S buglehead screws spaced 24" (610 mm) o.c. The second layer is placed vertically or horizontally (opposite of base layer) over the base layer and fastened using 1-5/8" (41 mm) No. 6 Type S screws spaced 12" (300 mm) on center. The face layer is attached to studs using 2-1/4" (57 mm) Type S or Type S-12 buglehead screws spaced 16" (406 mm) on center when applied vertically or 12" (300 mm) on center when applied horizontally. Exposed joints and screwheads are to be finished with CertainTeed Finishing system, or equivalent, unless otherwise specified. (Non-Loadbearing)

3 HR

VERTICAL SHAFTWALL SYSTEM

FINISHED ONE SIDE

FIRE TEST

cUL U417/ULC W446

SOUND REPORT

NOAL 18-0719 STC 54
with 2-1/2" (63.5 mm) C-T studs,
5/8" (15.9 mm) CertainTeed
Type X, and CertainTeed Fiber
Glass Insulation or equivalent

APPROX. THICKNESS

4-3/8" (111 mm)

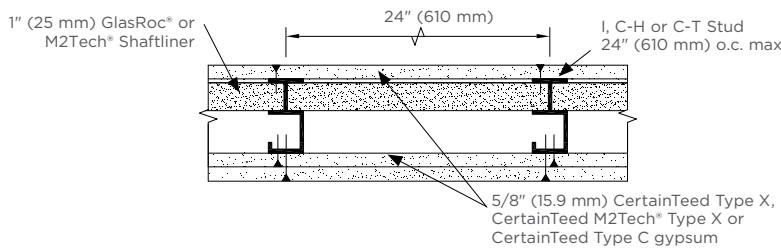

1" (25 mm) GlasRoc® or M2Tech® Shaftliner gypsum panels are inserted between 2-1/2" (64 mm), 4" (102 mm) or 6" (152 mm) I, C-H or C-T studs. 5/8" (15.9 mm) CertainTeed Type X, CertainTeed M2Tech® Type X, or CertainTeed Type C gypsum panels applied in two layers to one side of the assembly and one layer to the other side of the assembly. On the two-layer side, the base layer is applied vertically using 1" (25 mm) Type S or Type S-12 buglehead screws spaced 24" (610 mm) on center. The face layer is applied vertically or horizontally using 1-5/8" (41 mm) Type S or Type S-12 buglehead screws spaced 24" (610 mm) on center when applied vertically or 16" (406 mm) on center when applied horizontally. Joints and screwheads are to be finished with CertainTeed Finishing system, or equivalent, unless otherwise specified.

3 HR

VERTICAL SHAFTWALL SYSTEM

FINISHED BOTH SIDES

FIRE TEST

cUL U417/ULC W446

SOUND REPORT

NOAL 18-0720 STC 55
with 2-1/2" (63.4 mm) C-T studs,
5/8" (15.9 mm) CertainTeed
Type X, and CertainTeed Fiber
Glass Insulation or equivalent

APPROX. THICKNESS

4-3/8" (111 mm)

Vertical Systems

4 hour Fire Resistance Rating

FIRE RESISTANCE RATED SYSTEM DESIGNS FINISHED ONE SIDE

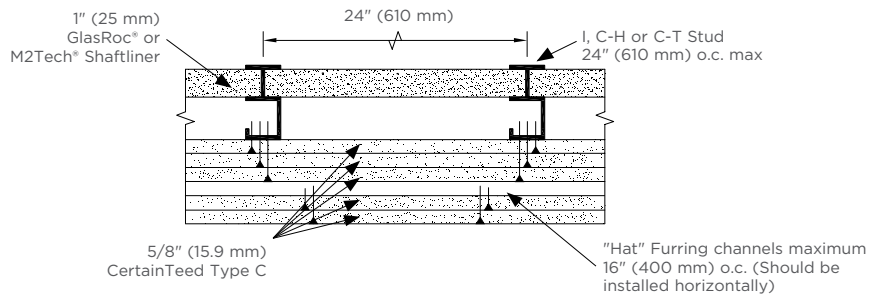

1" (25 mm) GlasRoc® or M2Tech® Shaftliner gypsum panels are inserted between 4" (102 mm) I, C-H or C-T studs. 5/8" (15.9 mm) CertainTeed Type C panels are applied vertically in five layers. Vertical joints centered over studs and staggered a minimum 24" (610 mm) o.c. The first layer is applied using 1-1/8" (28 mm) type S self-tapping screws spaced 12" (300 mm) o.c. The second layer is secured to the studs using 1-5/8" (41 mm) Type S self-tapping screws spaced 12" (300 mm) o.c. The third layer is secured to the studs using 2-1/4" (57 mm) Type S self-tapping screws spaced 12" (300 mm) o.c. The fourth layer is secured to the furring using 1-1/8" (28 mm) Type S self-tapping screws spaced 12" (300 mm) o.c. The fifth layer is secured to the furring channels using 1-5/8" (41 mm) Type S self-tapping screws spaced 12" (300 mm) o.c. Joints and screwheads are to be finished with the CertainTeed Finishing system, or equivalent, unless otherwise specified.

4 HR

VERTICAL SHAFTWALL SYSTEM
FINISHED ONE SIDE

FIRE TEST
UL/cUL W471

SOUND REPORT
NGC 2019098 STC 54
with CertainTeed Fiber Glass
Insulation or equivalent

APPROX. THICKNESS
8" (203 mm)

Vertical Assembly Details

SECTION DETAILS

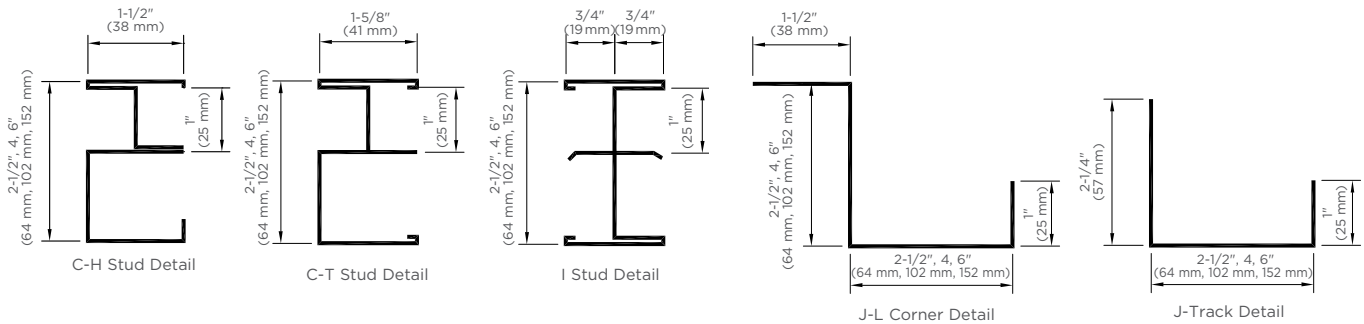

DETAILS - FINISHED ONE SIDE

OUTSIDE CORNER

INSIDE AND OUTSIDE CORNER

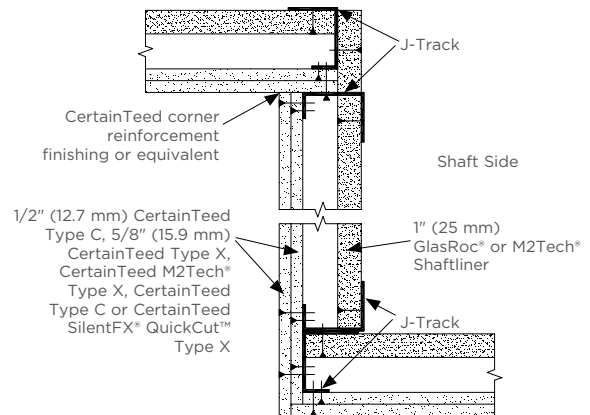
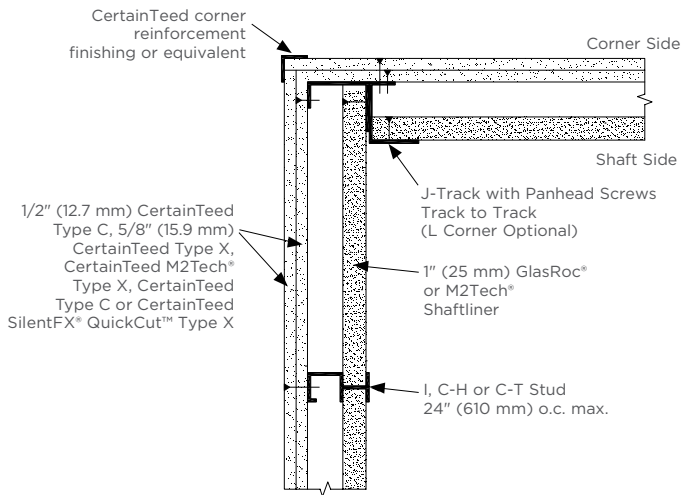

TYPICAL START/END OF WALL

ALTERNATE END OF WALL SECTION

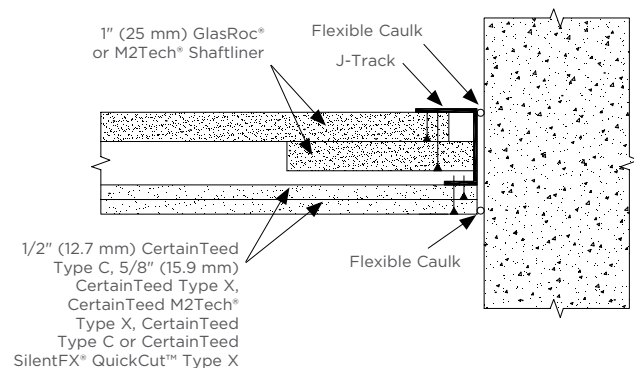
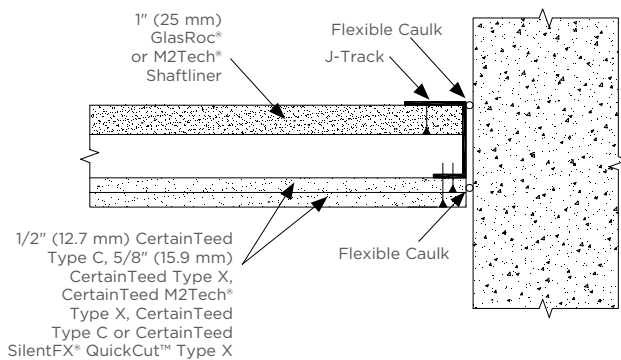

Vertical Assembly Details

WALL INTERSECTION ON SHAFTLINER SIDE

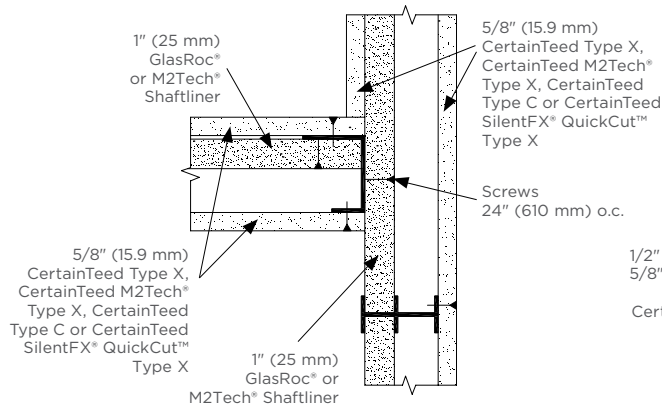

SEPARATION WALL INTERSECTION ON FINISHED SIDE

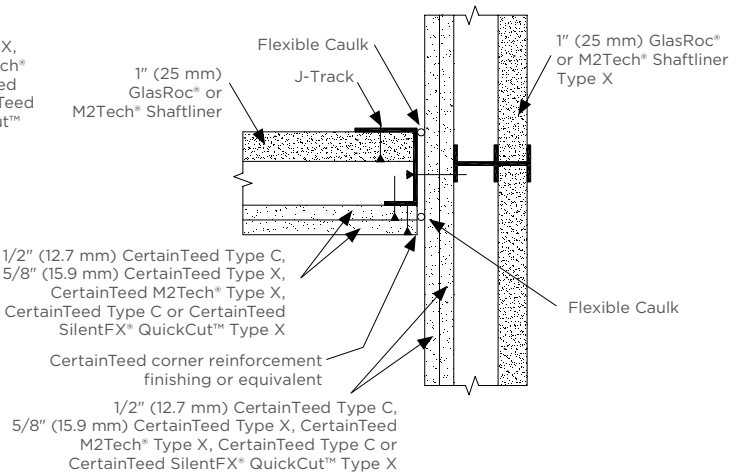

DETAILS - FINISHED BOTH SIDES

ABUTMENT TO MASONRY

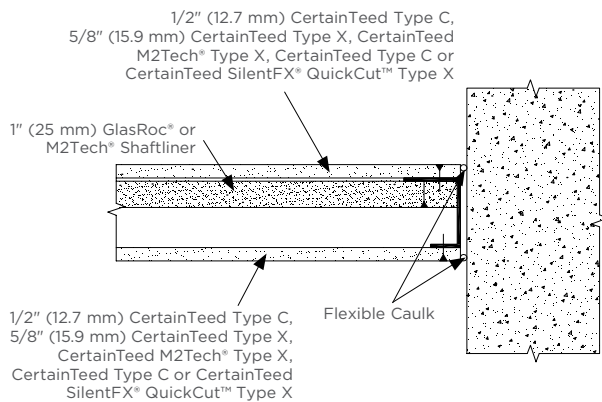

WALL INTERSECTION ON CAVITY SIDE

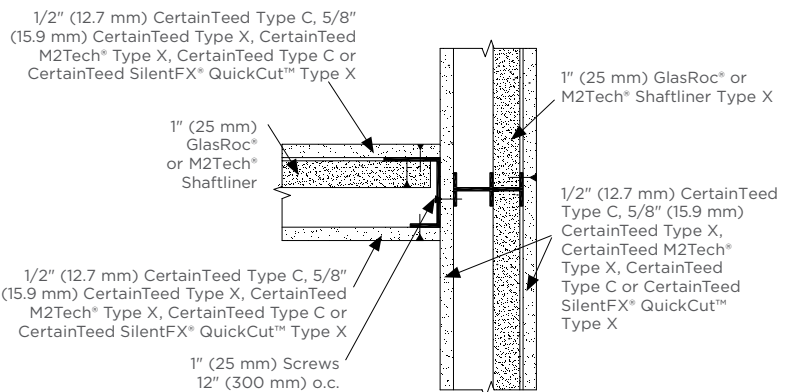

INSIDE AND OUTSIDE CORNER

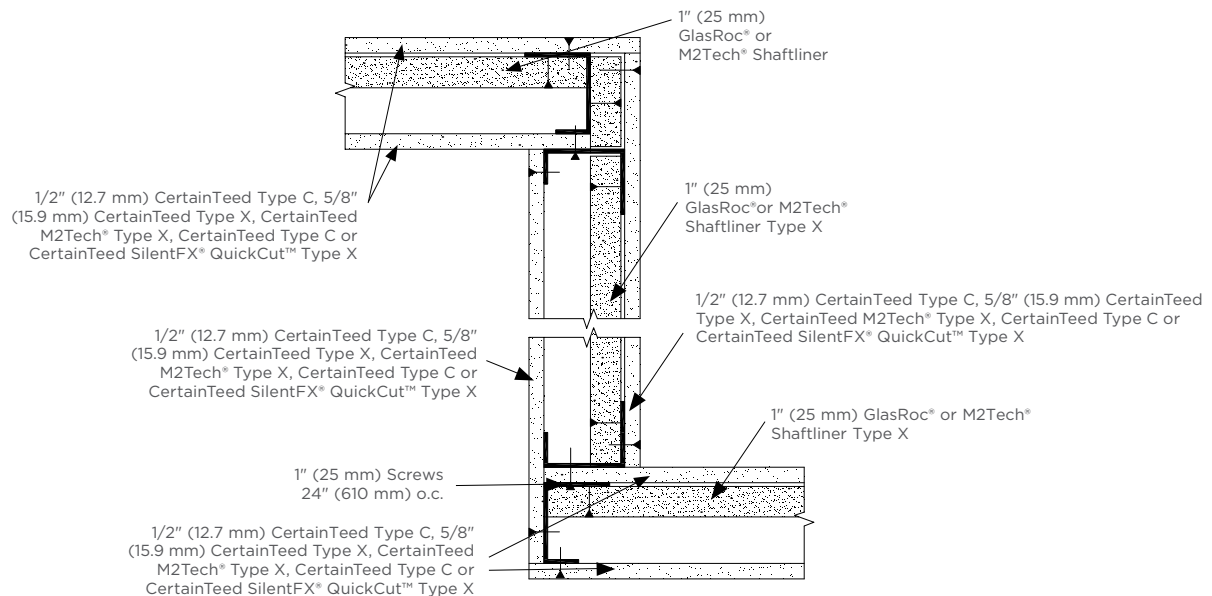

Additional Details

SHAFTWALL TO BEAM

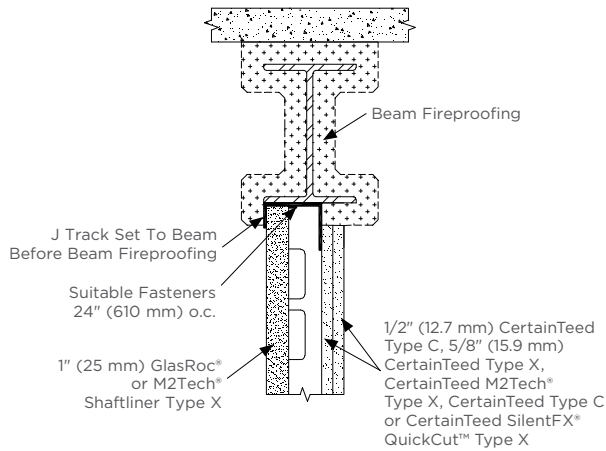

SHAFTWALL OFFSET FROM BEAM

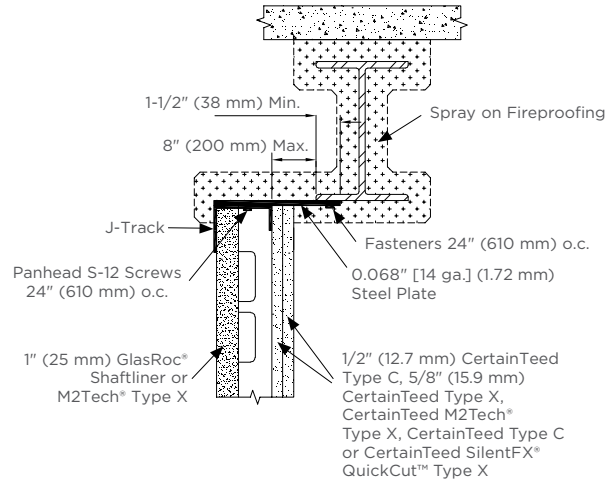

SHAFTWALL OFFSET FROM DECK

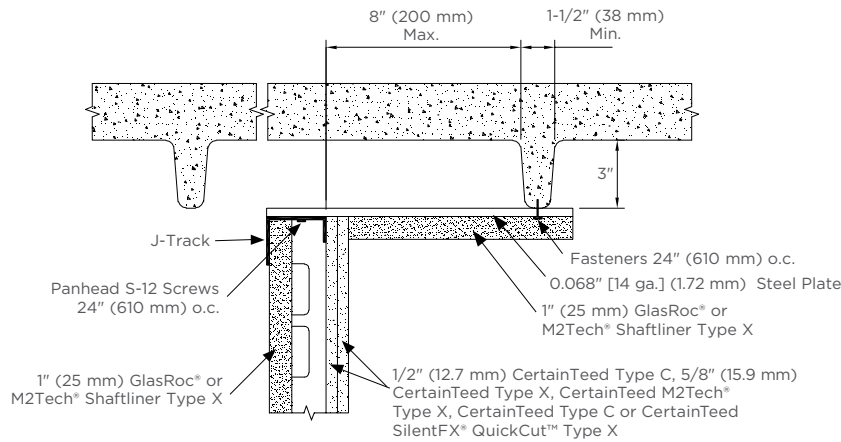

TOP AT BEAM AND FLOOR BYPASS

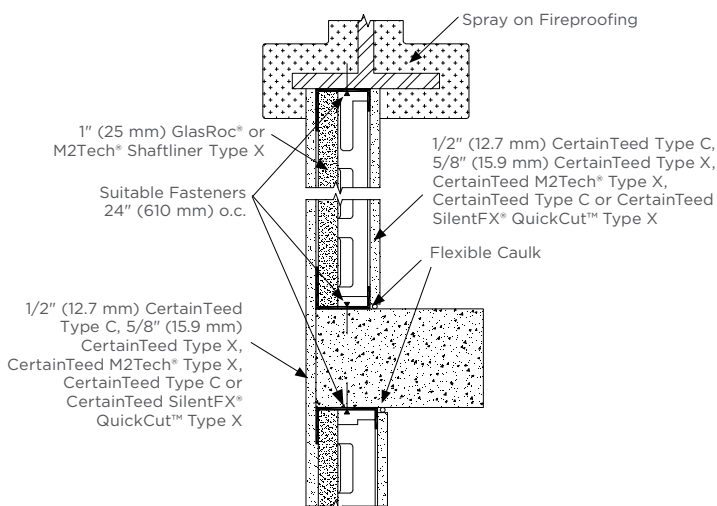

SHAFT CANT

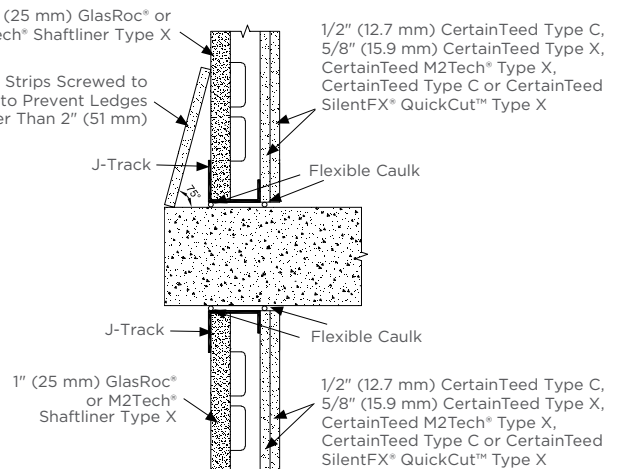

Additional Details

CORNER COLUMN BYPASS

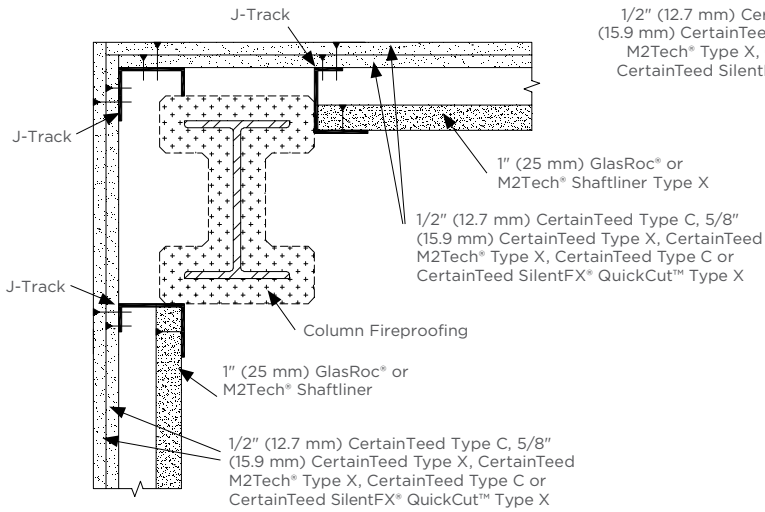

BYPASS OF LARGE COLUMNS

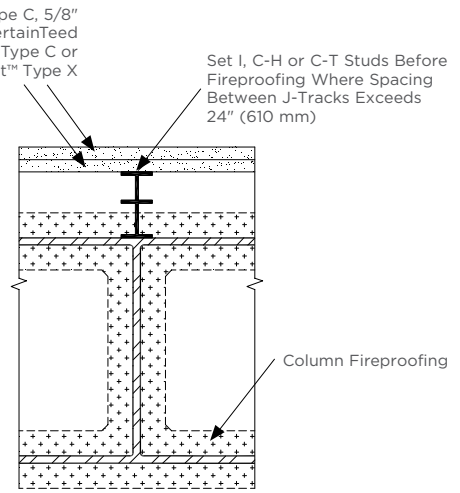

HAND RAIL ATTACHMENT DETAILS

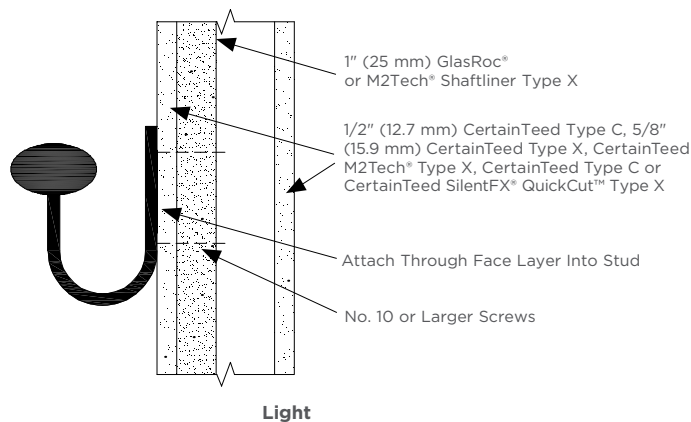
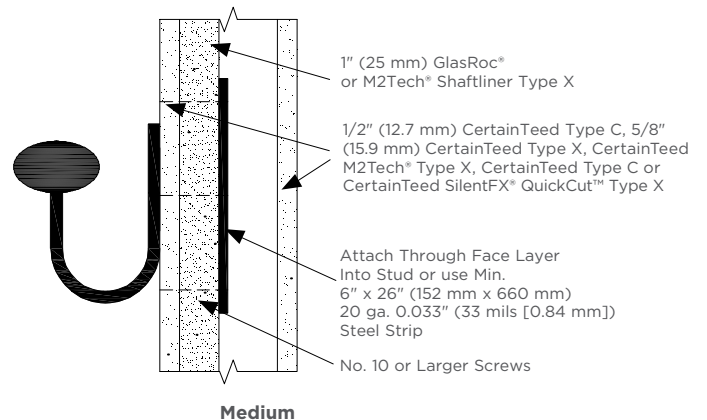
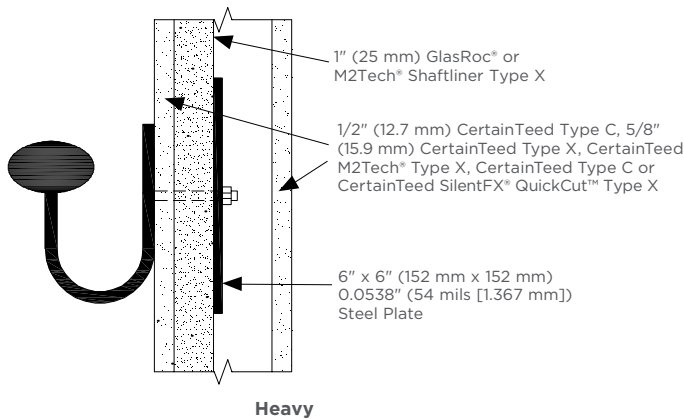

Accessory Details

SHAFTWALL ELECTRICAL CONTROL LAYOUT

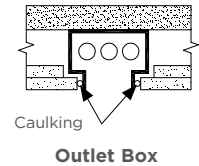
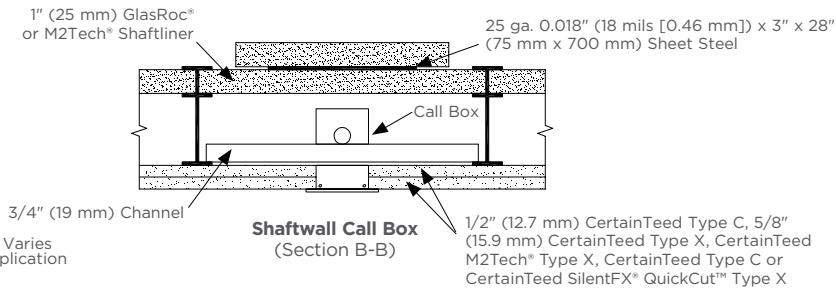
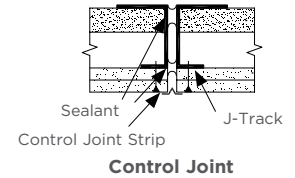
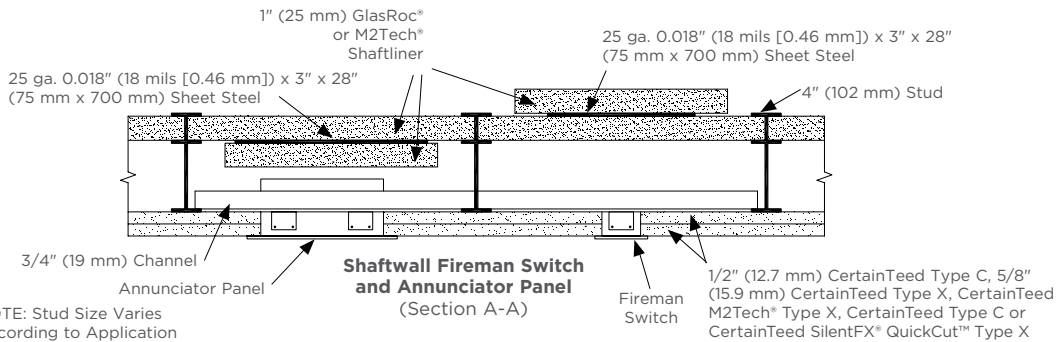
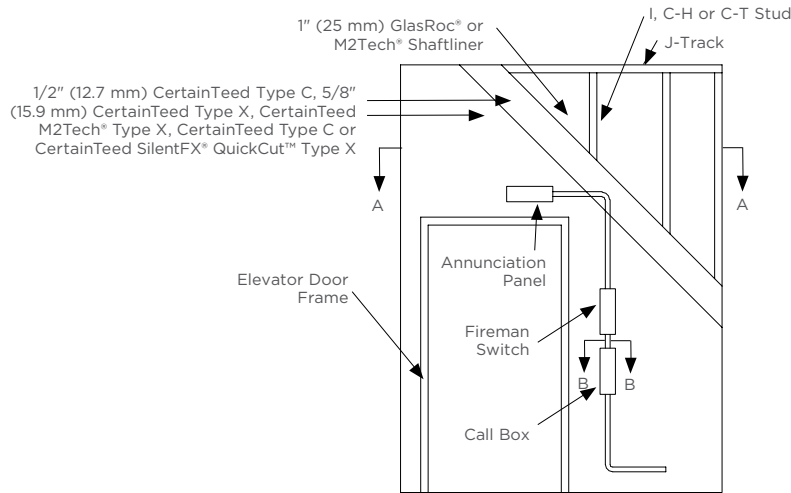

MAIL CHUTE

CHASE WALL

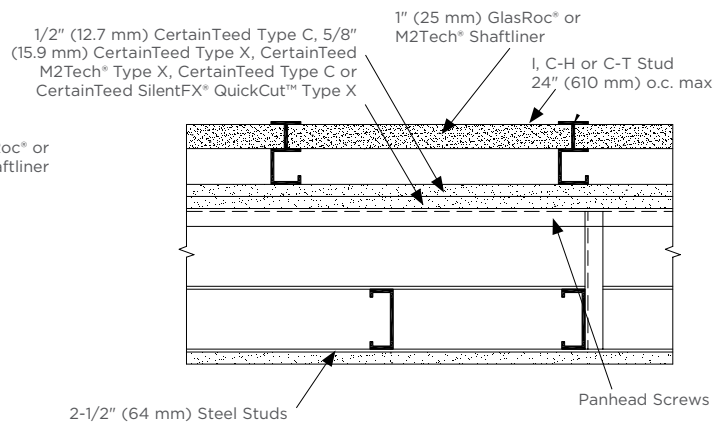
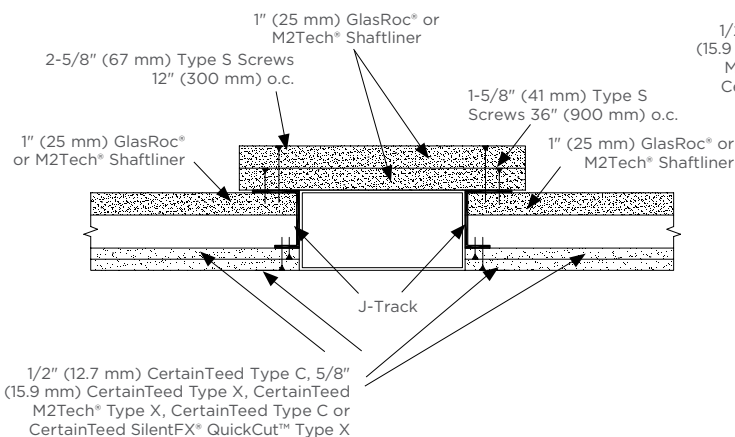

Openings and Elevator Details

ILLUSTRATED WITH 2 HR. RATED ASSEMBLY

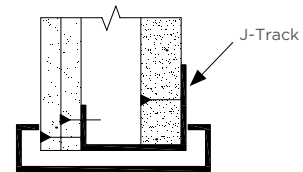
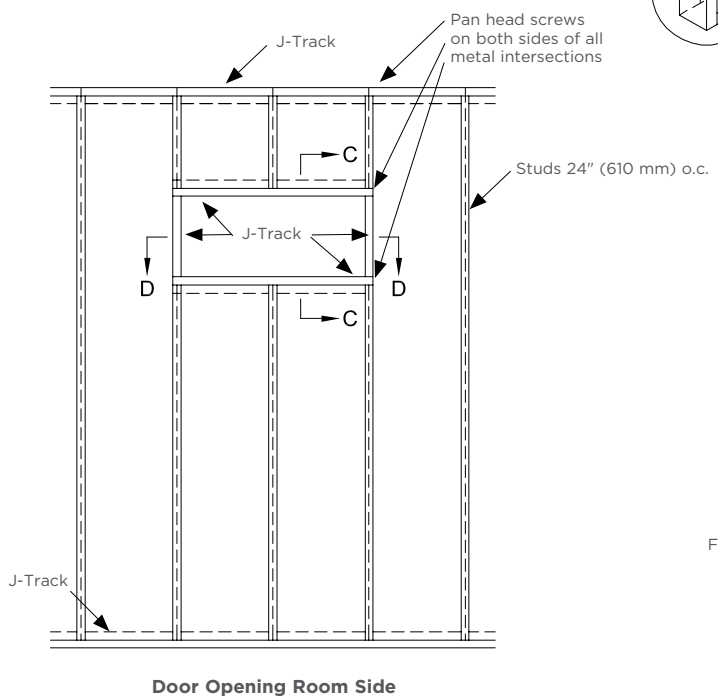
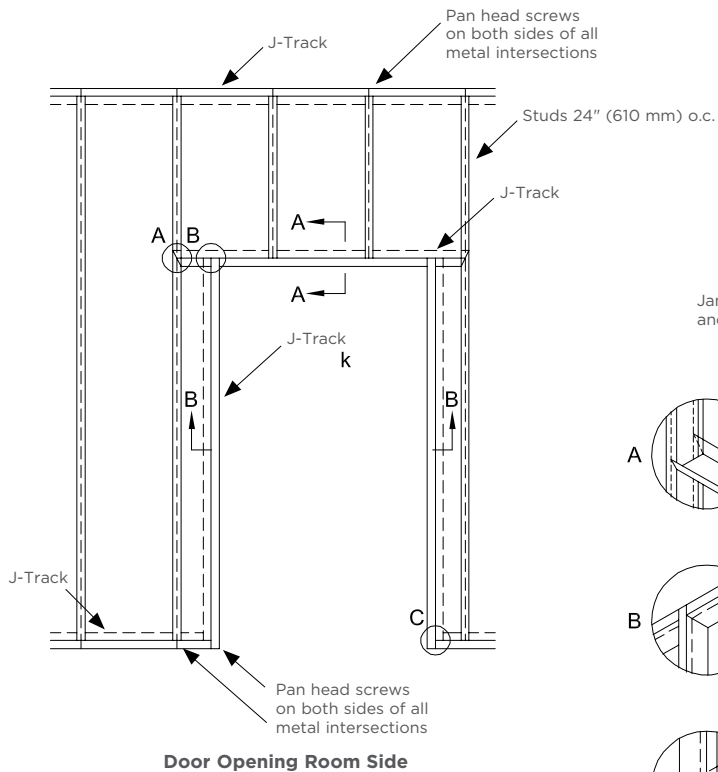

Header Section AA

Jamb trim grouted in place and/or attached to J-Track with jamb anchor clips

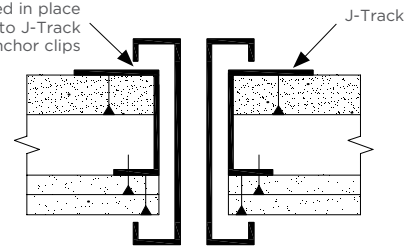

Cross Section B-B

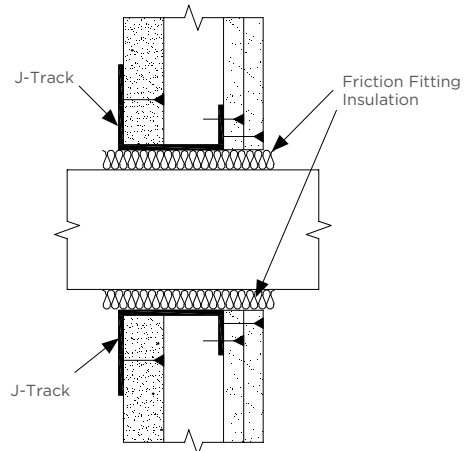
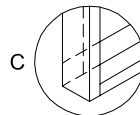
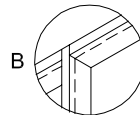

Duct Section C-C

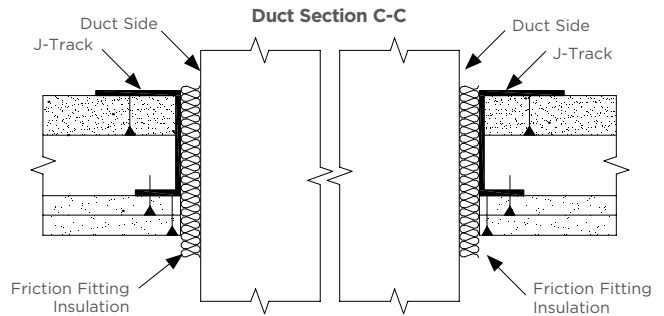

Duct Section D-D

NOTE:
Clearance openings and attachments details should be as per fire damper manufacturer's installation requirements

Elevator Door Frames 7' (2.13 m)

ONE HOUR DETAILS

ELEVATOR DOOR FRAMING

ELEVATOR DOOR HEAD

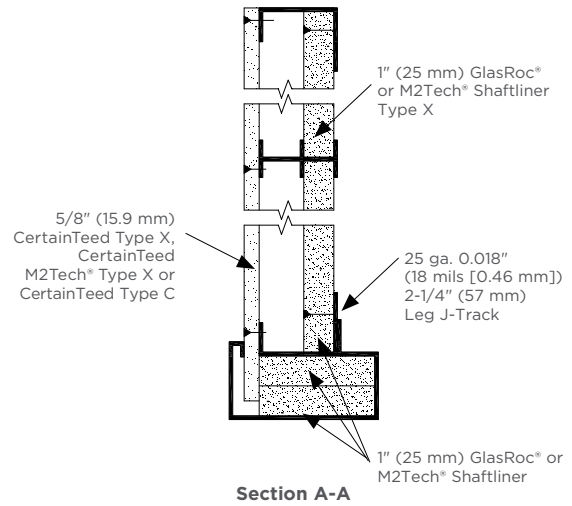
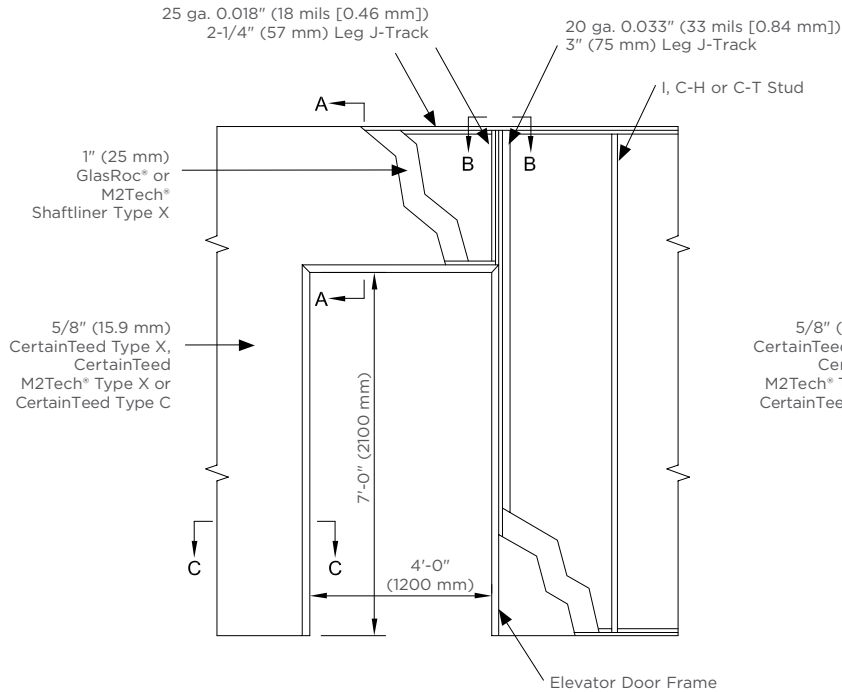

J-TRACK FRAMING ABOVE DOOR

ELEVATOR DOOR JAMB

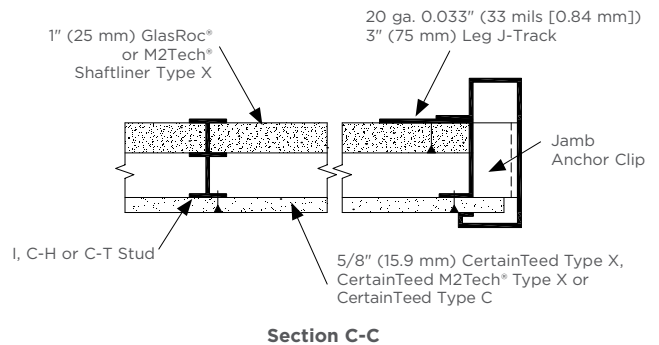
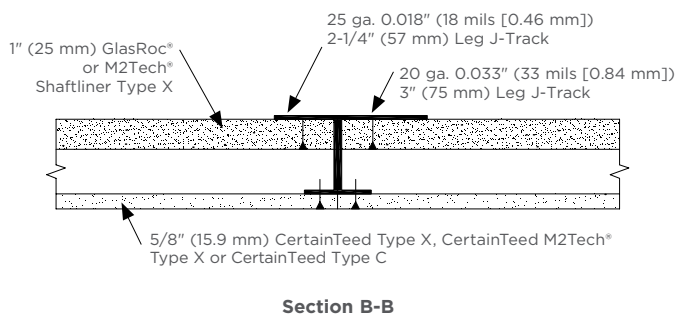

Elevator Door Frames Over 7' (2.13 m)

TWO HOUR DETAILS

ELEVATOR DOOR FRAMING

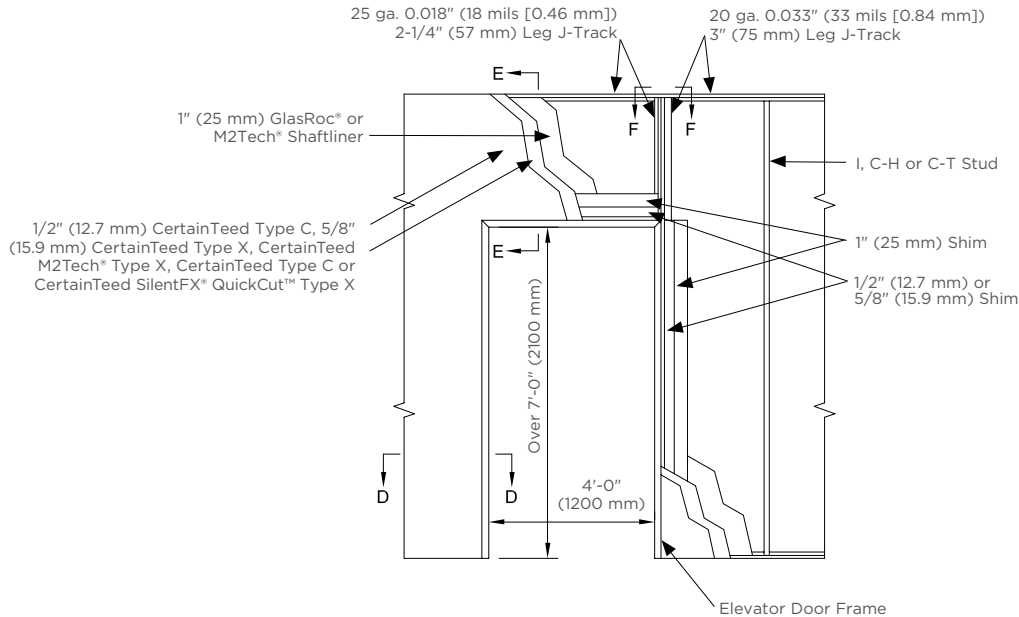

ELEVATOR DOOR JAMB

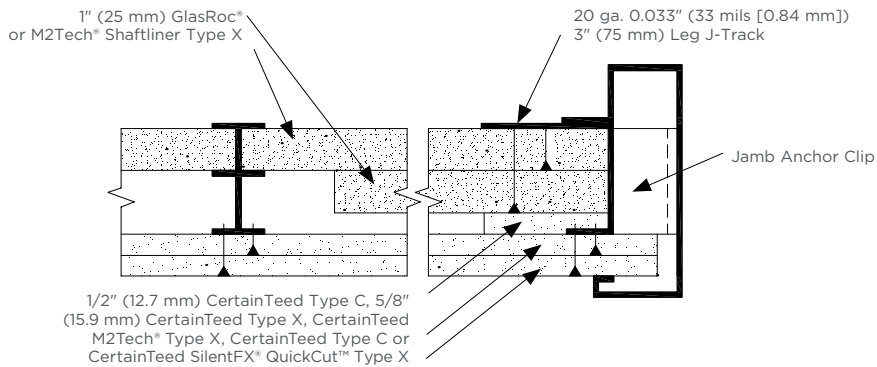

Section D-D

ELEVATOR DOOR HEAD

J-TRACK FRAMING ABOVE ELEVATOR DOOR

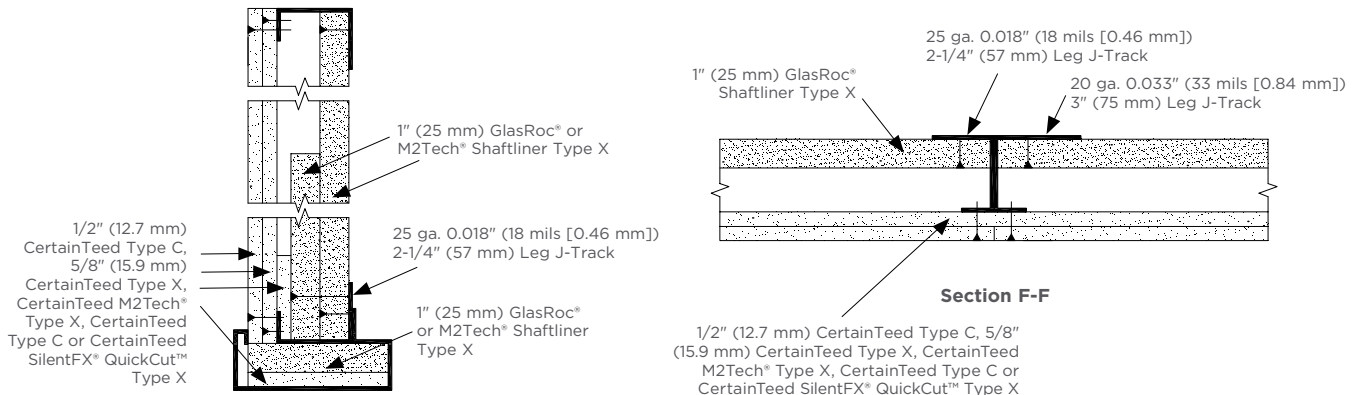

Horizontal Systems

1 and 2 Hour Fire Resistance Rating for Corridors

FIRE RESISTANCE RATED SYSTEM DESIGNS

Minimum 2-1/2" (64 mm), 25 gauge 0.018" (18 mils [0.46 mm]) thick, galvanized steel J-Track with unequal legs of 2" (51 mm) and 1" (25 mm) fastened to adjacent wall assembly with 1/2" (12.7 mm) Type S screws, spaced 24" (610 mm) o.c. J-Track attached with the 2" (51 mm) leg is on the top and the 1" (25 mm) leg on the bottom, facing the finished gypsum side of the ceiling.

1" (25 mm) GlasRoc® or M2Tech® Shaftliner Type X gypsum boards are inserted between a minimum 2-1/2" (64 mm), 25 gauge 0.018" (18 mils [0.46 mm]) thick, I, C-H, or C-T Studs. GlasRoc® or M2Tech® Shaftliner Type X gypsum boards are cut 1" (25 mm) shorter than the length of the J-Track to J-Track spacing. Corners of the GlasRoc® or M2Tech® Shaftliner Type X gypsum boards are secured to the J-Track with 1-5/8" (41 mm) Type S Screws.

Two layers of 5/8" (15.9 mm) CertainTeed Type X gypsum board are installed on the open stud face with the first layer installed at right angles to the I, C-H, or C-T Studs with 1" (25 mm) Type S screws spaced 12" (300 mm) o.c., starting 1-1/2" (38 mm) from side joints. Butt joint screws 1/2" (12.7 mm) from the joint edge. Butt joints are staggered a minimum of 6' (1828 mm) o.c. The second layer installed at right angles to the I, C-H, or C-T Studs with 1-5/8" (41 mm) o.c. Type S screws at 12" (300 mm) o.c., starting 1-1/2" (38 mm) o.c. Butt joint screws 1/2" (12.7 mm) from the joint edge. Butt joints are staggered a minimum of 24" (610 mm) o.c.

Unsupported length of studs should not exceed 96" (2438 mm) in length.

For spans exceeding 96" (2438 mm) in length, support is required by a suspension method as follows:

Minimum 4.1 mm thick (8 gauge) steel wire, spaced 24" (610 mm) o.c., hung from holes punched in a minimum 6" (152 mm), 25 gauge 0.018" (18 mils [0.46 mm]) thick, galvanized C Shaped Steel channel with minimum 1-1/4" (32 mm) legs and attached to a suitable supporting structure. The above referenced J-Track is secured to both sides of the C Shaped Steel channel with 1/2" (12.7 mm) Type S screws, spaced 24" (610 mm) o.c.

Minimum 2" (51 mm) thick, 6" (152 mm) wide mineral wool insulation placed on the surface of the 1" (25 mm) GlasRoc® or M2Tech® Shaftliner Type X gypsum boards and across the full length of the C Shaped Steel channel.

(Non-Loadbearing)

1 HR
HORIZONTAL
SHAFTWALL SYSTEM
FIRE TEST
UL/cUL I515

FRONT VIEW

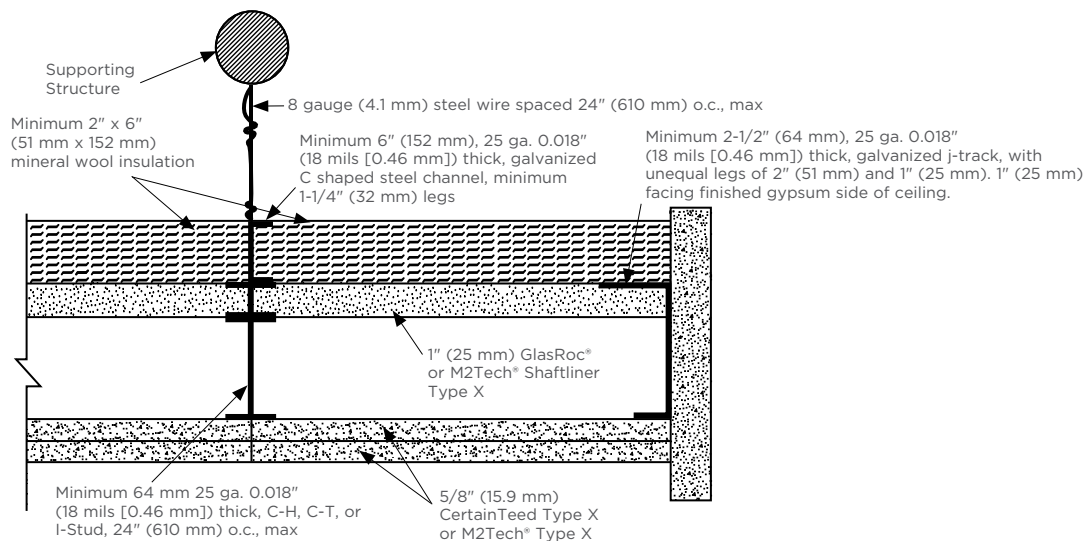

Horizontal Systems

1 and 2 Hour Fire Resistance Rating for Corridors

FIRE RESISTANCE RATED SYSTEM DESIGNS

SIDE VIEW (IF 2438 mm [96"] OR LESS CLEAR SPAN)

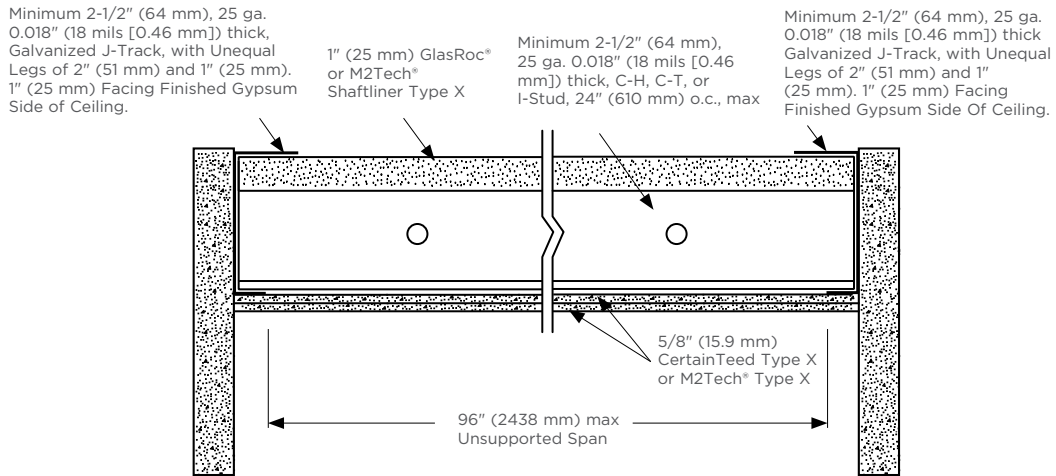

SIDE VIEW (IF OVER 96" [2438 mm] CLEAR SPAN)

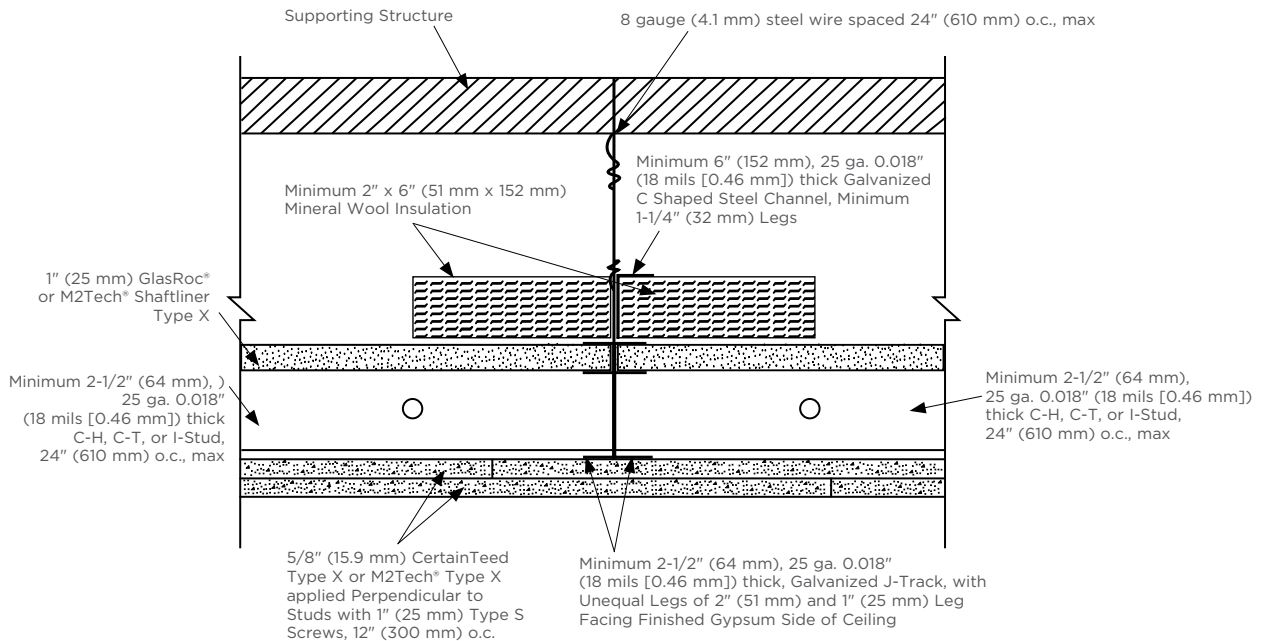

Horizontal Systems

1 and 2 Hour Fire Resistance Rating for Corridors

FIRE RESISTANCE RATED SYSTEM DESIGNS

Horizontal Shaftwall System

Minimum 2-1/2" (64 mm), 20 ga. 0.033" (33 mils [0.84 mm]), galvanized steel J-Track with unequal legs of 2" (51 mm) and 1" (25 mm) fastened to adjacent wall assembly with 1/2" (12.7 mm) Type S screws, spaced 24" (610 mm) o.c. J-Track attached with the 2" (51 mm) leg is on the top and the 1" (25 mm) leg on the bottom, facing the finished gypsum side of the ceiling.

1" (25 mm) GlasRoc® or M2Tech® Shaftliner Type X gypsum boards are inserted between a minimum 2-1/2" (64 mm), 0.033" (33 mils [0.84 mm]) thick, I, C-H, or C-T Studs. GlasRoc® or M2Tech® Shaftliner Type X gypsum boards are cut 1" (25 mm) shorter than the length of the J-Track to J-Track spacing. Corners of the GlasRoc® or M2Tech® Shaftliner Type X gypsum boards are secured to the J-Track with 1-5/8" (41 mm) Type S Screws.

Three layers of 5/8" (15.9 mm) CertainTeed Type C gypsum board are installed on the open stud face with resilient channel between the 2nd layer and 3rd (face) layer. The first layer installed at right angles to the C-H, I or C-T Studs with 1" (25 mm) Type S screws spaced 12" (300 mm) o.c., starting 1-1/2" (38 mm) from side joints. Butt joint screws 1/2" (12.7 mm) from the joint edge. Butt joints are staggered a minimum of 6" (152 mm) o.c. The second layer installed at right angles to the C-H, I or C-T Studs with 1-5/8" (41 mm) o.c. Type S screws at 12" (300 mm) o.c., starting 1-1/2" (38 mm) o.c. Butt joint screws 1/2" (12.7 mm) from the joint edge. Butt joints are staggered a minimum of 24" (610 mm) o.c. 20 ga. 0.033" (33 mils [0.84 mm]) thick Resilient channel installed 16" (406 mm) o.c., perpendicular to the C-H, I or C-T Studs with 1-5/8" (41 mm) Type S bugle head screws, spaced 12" (300 mm) o.c. Resilient Channels overlapped 4" (102 mm) at splices. Two channels spaced 4" (102 mm) o.c., oriented opposite at each gypsum panel butt joint. The third layer (face layer) installed parallel to the direction of the C-H, I or C-T Studs to the resilient channels with 1" (25 mm) Type S screws spaced 12" (300 mm) o.c. Butt joint screws 1/2" (12.7 mm) from the joint edge. Butt joints are staggered a minimum of 24" (610 mm) o.c.

Nominal 4" (102 mm) x 6" (152 mm) wide mineral wool placed over the surface of the C-Channel and Studs. Mineral wool should cover the C-Channel and Studs so all visible metal surfaces are covered.

Unsupported length of studs should not exceed 96" (2438 mm) in length.

For spans exceeding 96" (2438 mm) in length, support is required by a suspension method as follows:

Minimum 4.1 mm thick (8 gauge) steel wire, spaced 24" (610 mm) o.c., hung from holes punched in a minimum 6" (152 mm), 18 mils (0.46 mm) galvanized C Shaped Steel channel with minimum 1-1/4" (32 mm) legs and attached to a suitable supporting structure. The above referenced J-Track is secured to both sides of the C Shaped Steel channel with 1/2" (12.7 mm) Type S screws, spaced 24" (610 mm) o.c. Minimum 2" (51 mm) thick, 6" (152 mm) wide mineral wool insulation placed on the surface of the 1" (25 mm) GlasRoc® or M2Tech® Shaftliner Type X gypsum boards and across the full length of the C Shaped Steel channel.

(Non-Loadbearing)

2 HR
HORIZONTAL
SHAFTWALL SYSTEM
FIRE TEST
UL/cUL 1515

FRONT VIEW

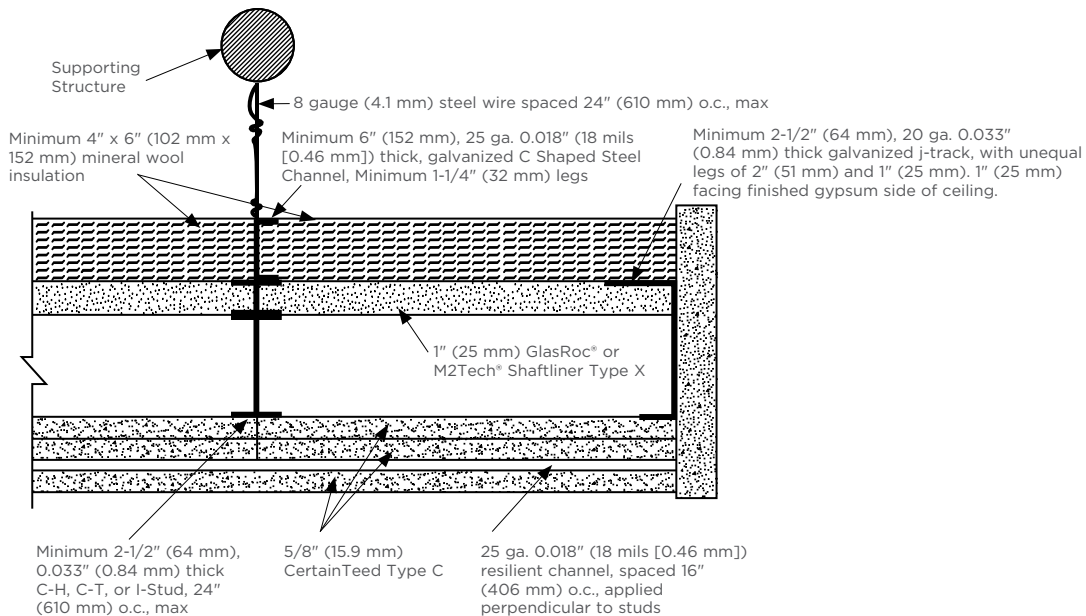

Horizontal Systems

1 and 2 Hour Fire Resistance Rating for Corridors

FIRE RESISTANCE RATED SYSTEM DESIGNS

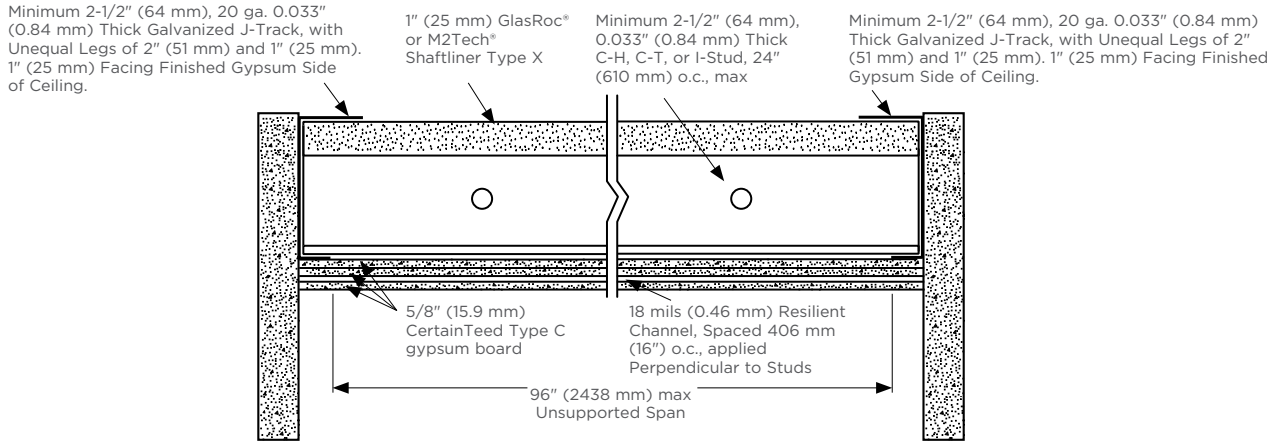

SIDE VIEW (IF OVER 96" [2438 mm] CLEAR SPAN)

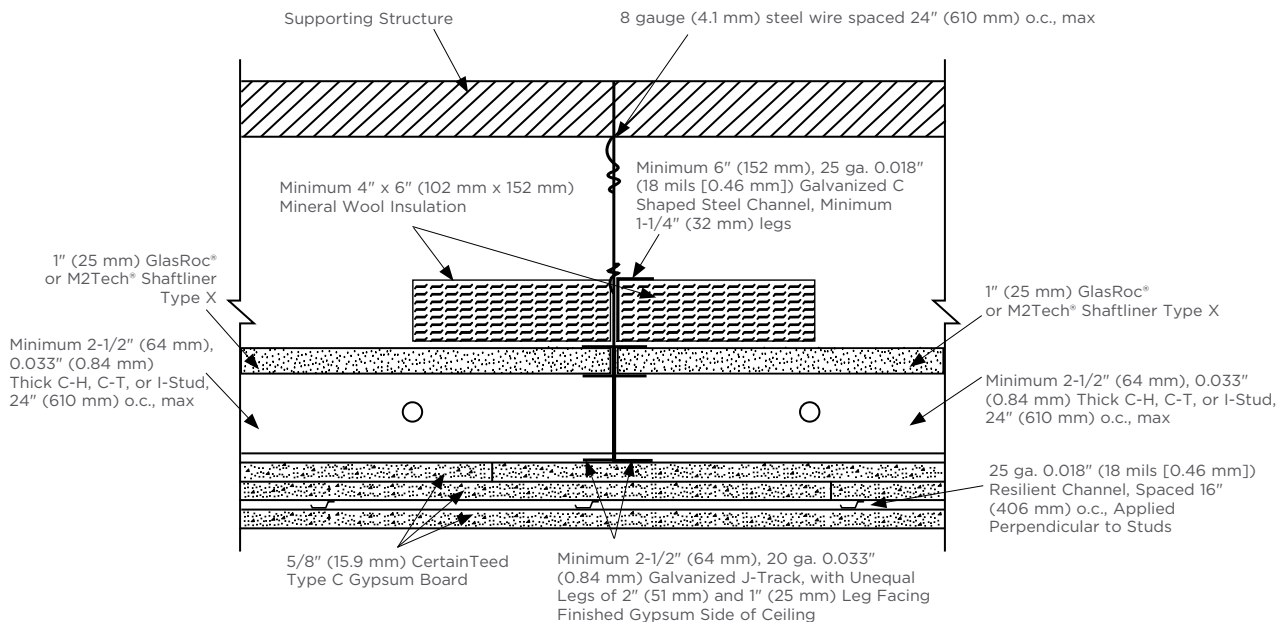

Horizontal Systems

1 and 2 Hour Fire Resistance Rating for Corridors

FIRE RESISTANCE RATED SYSTEM DESIGNS

Horizontal Membrane for Duct Enclosure For corridors, ducts, enclosures, etc.

2 HR

HORIZONTAL MEMBRANE
FOR DUCT ENCLOSURE

FIRE TEST
FIRE: UL 1515

UL U417/ULC W446,
Systems A or C
(Vertical Section)

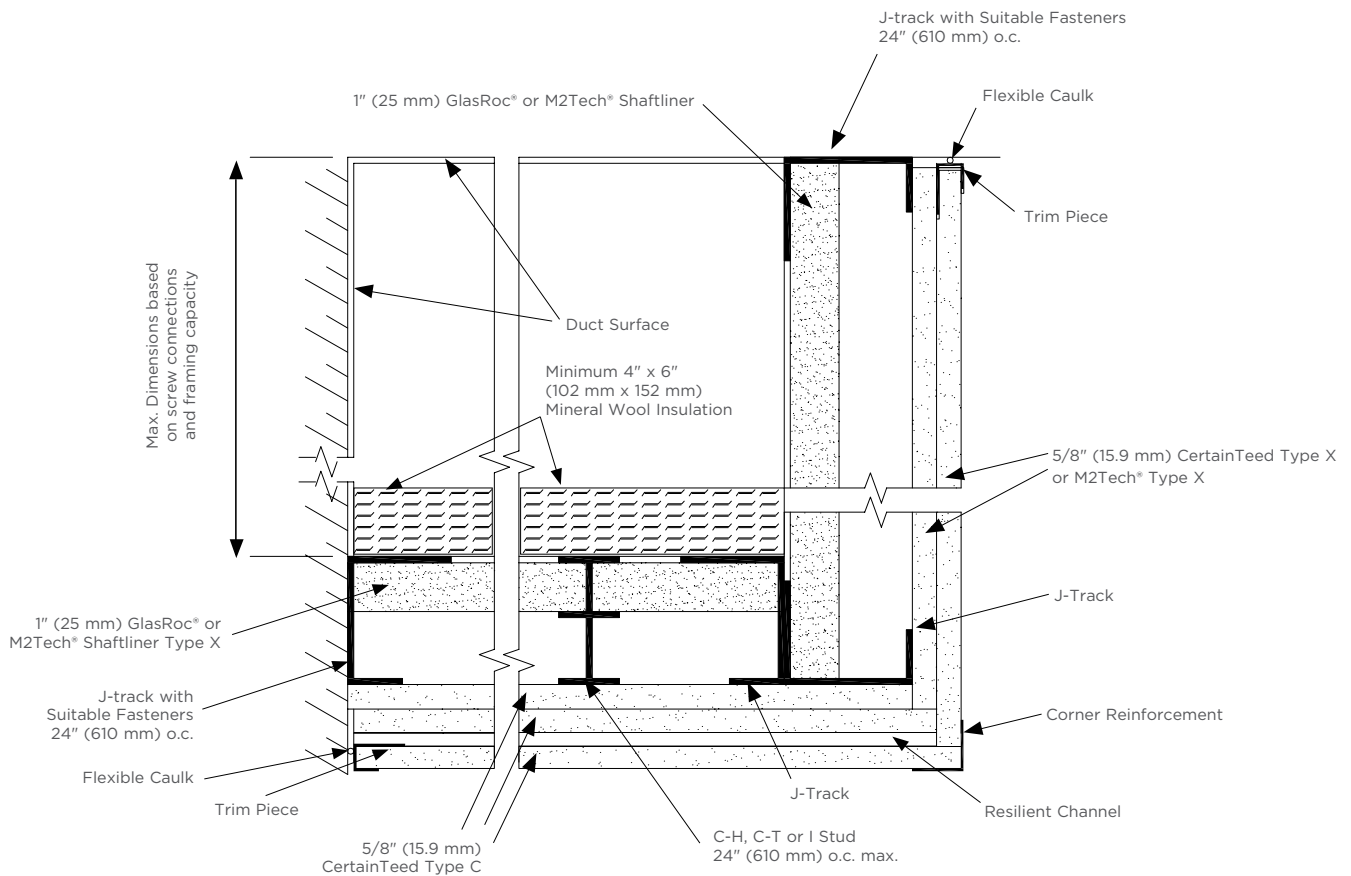

MAXIMUM 96" (2440 mm) UNSUPPORTED HORIZONTAL SPAN

HORIZONTAL DUCT ENCLOSURE



Architectural Specifications

Section 09 21 16.23

Gypsum Panel Shaftwall Assemblies

PART 1-GENERAL

1.1 PROJECT DESCRIBED

Non-loadbearing one or two hour fire resistance rated shaftwall systems, staircase enclosures, or other mechanical enclosures.

1.2 QUALIFICATIONS

All gypsum materials used in the described system installations shall be manufactured by CertainTeed and carry CertainTeed brand identity. CertainTeed or its representative will provide verification that the products applicable to the described performance specification meet the applicable ASTM standards for performance described herein. Additional framing materials including J-Track, I-Stud, C-H Stud or C-T Stud and fasteners must be supplied and installed in accordance with printed installation instructions as instructed by the manufacturer and required by the testing agencies.

1.3 SUBMITTALS

Submit system descriptions and construction guide brochures for each assembly indicating component materials, fasteners, finishes, dimensions and related information showing compliance with stated construction guidelines.

1.4 DELIVERY, STORAGE, HANDLING

GlasRoc® gypsum panels are delivered in original, unopened containers or wrapped and stacked flat on a smooth, level surface, but not stored directly on concrete floors. When spacers are used, they are positioned closely enough together to minimize warpage. Care is taken to prevent damage to edges and corners. Always keep GlasRoc®, CertainTeed, M2Tech® and

SilentFX® QuickCut™ gypsum panels dry prior to installation. Do not use shipping bags for outdoor storage of material.

1.5 INSTALLATION ENVIRONMENT

GlasRoc® and all gypsum panel must not be used in areas that are continuously or repeatedly exposed to excessive moisture or temperatures above 125°F (52°C). No treatment of joints shall be done until the interior temperature has been maintained at a minimum of 50°F (10°C) for at least 48 hours prior to application of joint treatment materials. Adequate continuous ventilation must also be provided during the finishing of joints.

Joints, corners and fastener heads shall be finished in accordance with ASTM C840, the GA-216, the Fire Resistance Design Manual GA-600, and CertainTeed Joint Compound manufacturer's instructions. Joint Compound shall comply with ASTM C475. No finishing is required on the shaft side of partitions.

For further technical information regarding sound control and fire resistance refer to the following reports:

Vertical Shaftwalls

UL/cUL U417, U428, U429, U469, U505, U529, V433, V470, W409, W437, W453, W471, ULC W446

Horizontal Shaftwalls

UL/cUL I515

PART 2-PRODUCTS

2.1 MATERIALS

A. Steel Framing

Studs complying with the requirements for ASTM A 653 SS Grade 33.

A-1. Stud Form

Studs can be in the form of I, C-H or C-T Studs with J-Tracks.

A-2. Stud Width

Galvanized I, C-H or C-T Studs are available in widths of 2-1/2", 4", and 6" (64 mm, 102 mm and 152 mm).

A-3. Stud Thickness

Studs are manufactured from steel having minimum design steel thicknesses from 0.0188" to 0.0451" (0.478 mm to 1.146 mm).

A-4. Stud Coating

Studs have a G40 or G60 galvanized coating.

B. Fasteners

1-5/8" (41 mm) long No. 6 Type S screws, 1" (25 mm) long No. 6 Type S buglehead screws, 3/8" (10 mm), long Type S panhead screws.

C. CertainTeed Gypsum Panel Products

- C-1. GlasRoc® or M2Tech® Shaftliner 1" (25 mm) thick
- C-2. CertainTeed Type C 1/2" (12.7 mm) thick
- C-3. CertainTeed or M2Tech® Type X 5/8" (15.9 mm) thick
- C-4. SilentFX® Quick Cut™ Type X 5/8" (15.9 mm) thick
- C-5. CertainTeed Type C 5/8" (15.9 mm) thick



Architectural Specifications *continued*

D. CertainTeed Joint Finishing

- D-1 CertainTeed Brand Ready Mixed Joint Compound
- D-2 CertainTeed Brand Joint Tape
- D-3 CertainTeed M2Tech® 90 Setting Compound

E. CertainTeed High Performance Corners

- F. Green Glue Noiseproofing Sealant, or equivalent

G. CertainTeed Fiber Glass Insulation, or equivalent.

H. Resilient Channels

PART 3-INSTALLATION

3.1 CONSTRUCTION BRIEFS

General

Construction consists of steel studs and tracks faced on one side with GlasRoc® or M2Tech® Shaftliner and on the opposite side with, one or two (depending on the application specifications) layers of either 1/2" (12.7 mm) CertainTeed Type C, 5/8" (15.9 mm) CertainTeed or M2Tech® Type X gypsum panel. The following steps pertain to one or two hour fire rated installation with one finished side:

1. Plan and lay out metal framing components to ensure that all wall sections are plumb and properly aligned.
2. Install J-Track along the ceiling line and vertically at columns and abutting partitions, positioning the long legs closest to the shaft. Secure each piece with the appropriate power driven fasteners spaced a maximum 24" (610 mm) o.c.
3. Attach J-Track to the floor with fasteners spaced at 24" (610 mm) o.c.

4. Install GlasRoc® or M2Tech® Shaftliner gypsum panels vertically with the logo side facing weather exposure during construction. The leading edge of the first panel must be attached to the long leg of the vertical J-Track with 1-5/8" (41 mm) Type S screws spaced 12" (300 mm) o.c. or by using the tabs in the J-track. Secure the top and bottom edges using the same fasteners and spacing, filling the stud cavity with CertainTeed Fiber Glass Insulation, or equivalent.

5. Friction fit an I, C-H or C-T Stud into the top and bottom tracks and slide it snugly against the GlasRoc® or M2Tech® Shaftliner gypsum panel. Make sure the edge of the panel is in full contact with the center web of stud and covered by all of the tabs.

6. Place the next GlasRoc® or M2Tech® Shaftliner gypsum panel between the tabs and flange on the opposite side of the I, C-H or C-T Stud with no screw attachments required.

7. Install subsequent GlasRoc® or M2Tech® Shaftliner gypsum panels and I, C-H or C-T Stud in the same manner. Check periodically to ensure they are plumb.

8. For walls exceeding 12' (3660 mm) in height, GlasRoc® or M2Tech® Shaftliner gypsum panel end joints should fall alternately in the upper and lower 1/3 height of the partition. Joints may be butted together or use an I, C-H or C-T Stud placed horizontally between panels to secure each joint.

9. Frame all cut openings in the shaft side with J-Track, providing adequate structural support for openings over 48" (1220 mm).

10. Elevator door frames should be tied to shaftwall enclosures, however, must remain independently supported by the building frame.

Installation of Finished Side

1. Apply a single layer of 5/8" (15.9 mm) CertainTeed or M2Tech® Type X or 1/2" (12.7 mm) CertainTeed Type C with gypsum panel with 1" (25 mm) Type S screws for one hour rated applications. Apply a second layer with 1-5/8" (41 mm) Type S screws for two hour rated applications, and a third layer with 2-1/4" (57 mm) Type S screws for three hour rated applications. Alternate layers between horizontal and vertical attachment so that outside layer is installed vertically.
2. Holding the gypsum panel firmly against the framing, begin fastening in the center of each sheet and move outward to ends and edges.
3. Set fastener heads slightly below the surface without breaking the face paper or damaging the gypsum core.
4. Install sheets in a brick pattern with all ends supported by framing members.

For finishing both sides, apply a single layer of 5/8" (15.9 mm) CertainTeed Type X, CertainTeed M2Tech® Type X or 1/2" (12.7 mm) CertainTeed Type C vertically over GlasRoc® or M2Tech® Shaftliner gypsum panel with 1" (25 mm) Type S screws. For sound rated partitions follow instructions that include filling the stud cavity with CertainTeed Fiber Glass Insulation or equivalent insulation and installation of finish side board onto resilient furring channels.



Innovative Building Solutions

CertainTeed provides innovative building products and systems for commercial, institutional and residential designs. With over 80 years of experience manufacturing and marketing in North America, CertainTeed Gypsum is committed to focusing on quality, service, and safety to provide a superior experience to its customers.

TEST STANDARDS

Fire resistance and sound tests are conducted in accordance with CAN/ULC S101, UL 263, ASTM E119 and ASTM E90, respectively, and no warranty is made other than conformance to the standard under which the assembly was tested. Minor discrepancies may exist in the values of ratings, attributable to changes in materials and standards, as well as differences between testing facilities. Assemblies are listed as “combustible” (wood framing) and “noncombustible” (concrete and/or steel construction).

COMBUSTIBLE ASSEMBLIES

These include all wood stud walls, wood joist or truss ceilings and floors consisting of tongue-and-groove, plywood, or OSB sub-flooring and finish flooring or a poured gypsum floor underlayment over wood structural panel sub-flooring. Floor assembly may be used over the wood joists with ceilings as detailed in GA and UL/cUL/ULC references.

NONCOMBUSTIBLE ASSEMBLIES

These include steel studs, bar joist ceilings with poured concrete floors over metal lath or steel. Also included are steel beams and steel columns. Ceilings for all 1-hour, 1-1/2-hour, and 2-hour noncombustible floor and ceiling assemblies with 2” (51 mm) or 2-1/2” (63.5 mm) concrete floor or metal lath over steel bar joists, unless otherwise specified, may be directly attached or suspended as detailed in GA and UL/cUL/ULC references.

FIRE RESISTANCE

CertainTeed Type X and Type C, M2Tech® Type X, SilentFX® QuickCut™ Type X, GlasRoc® Tile Backer Type X, GlasRoc Shaftliner Type X, GlasRoc Interior Type X and GlasRoc Sheathing Type X products are Classified by Underwriters Laboratories Inc. and Listed by Underwriters Laboratories of Canada and carries the UL/cUL/ULC Label for 1-, 2-, 3- and 4-hour Fire Resistance in various designs. Underwriters Laboratories Inc. tests have proven that joint finishing is not required for the rating in certain assemblies using Type X and Type C products. For fire resistance ratings, refer to the Gypsum Association Fire Resistance Design Manual GA-600, and the UL, cUL and ULC Fire Resistance Directories.

SURFACE BURNING CHARACTERISTICS

CertainTeed® Gypsum Panels have Flame Spread ratings of 0 to 15 and Smoke Developed ratings of 0 to 5, and GlasRoc® products have Flame Spread Ratings of 0 and Smoke Developed Ratings of 0 in accordance with CAN/ULC S102 (ASTM E84, UL 723).

SOUND CHARACTERISTICS

The degree to which assemblies block the passage of sound is measured by Sound Transmission Class (STC) per ASTM E90 and E413, which is a single figure rating derived from the sound transmission loss values over a range of sound frequencies. All sound-rated assemblies require acoustical sealant at assembly perimeters and penetrations, and other locations where sound leaks may develop. For sound characteristics, refer to the Gypsum Association Fire Resistance Design Manual GA-600.

STORAGE

Gypsum panels must be stored in an area that protects it from adverse weather conditions, condensation and other forms of moisture and direct sunlight. Panels should be neatly stacked flat with care taken to prevent sagging or damage to edges, ends, and surfaces. Storing panels lengthwise leaning against the framing is not recommended. Panels should be carried, not dragged, to place of installation to prevent damaging finished edges. Refer to “Handling and Storage of Gypsum Panel Products” GA-801.

MORE INFORMATION

Consult the Gypsum Association publication “Recommended Specifications for the Application and Finishing of Gypsum Panel,” GA-216, for detailed application and finishing procedures. For full details of fire and sound ratings, consult test references listed for system assemblies.



- 12 month limited warranty against weather exposure for GlasRoc® Shaftliner
- Resists mold growth per ASTM D3273
- Economical and efficient installation
- One sided construction of Shaftwalls eliminates the need for extensive scaffolding
- Scores and snaps easily with no special handling required
- Added protection from moisture during construction
- UL/cUL Classified and ULC Listed for Fire Resistance
- Rapid ease of installation reduces overall construction time and provides a cost effective system
- BIM/CAD Information UL fire rated assemblies and sound assemblies can be found on CertainTeed's BIM and CAD Design studio at bimlibrary.saint-gobain.com.
- Sustainable documentation, including recycled content, EPD's, HPD's, and VOC Certifications, can be found at saintgobain.ecomedes.com.

learn more at:
certainteed.com/drywall

USGBC® and the related logo are trademarks owned by the U.S. Green Building Council® and are used with permission.



The Health Product Declaration® logo is a trademark or service mark of Health Product Declaration Collaborative, Inc., in the United States and in other countries and is being used herein under license.

