

# Terminus Trim Drywall

INSTALLATION MANUAL

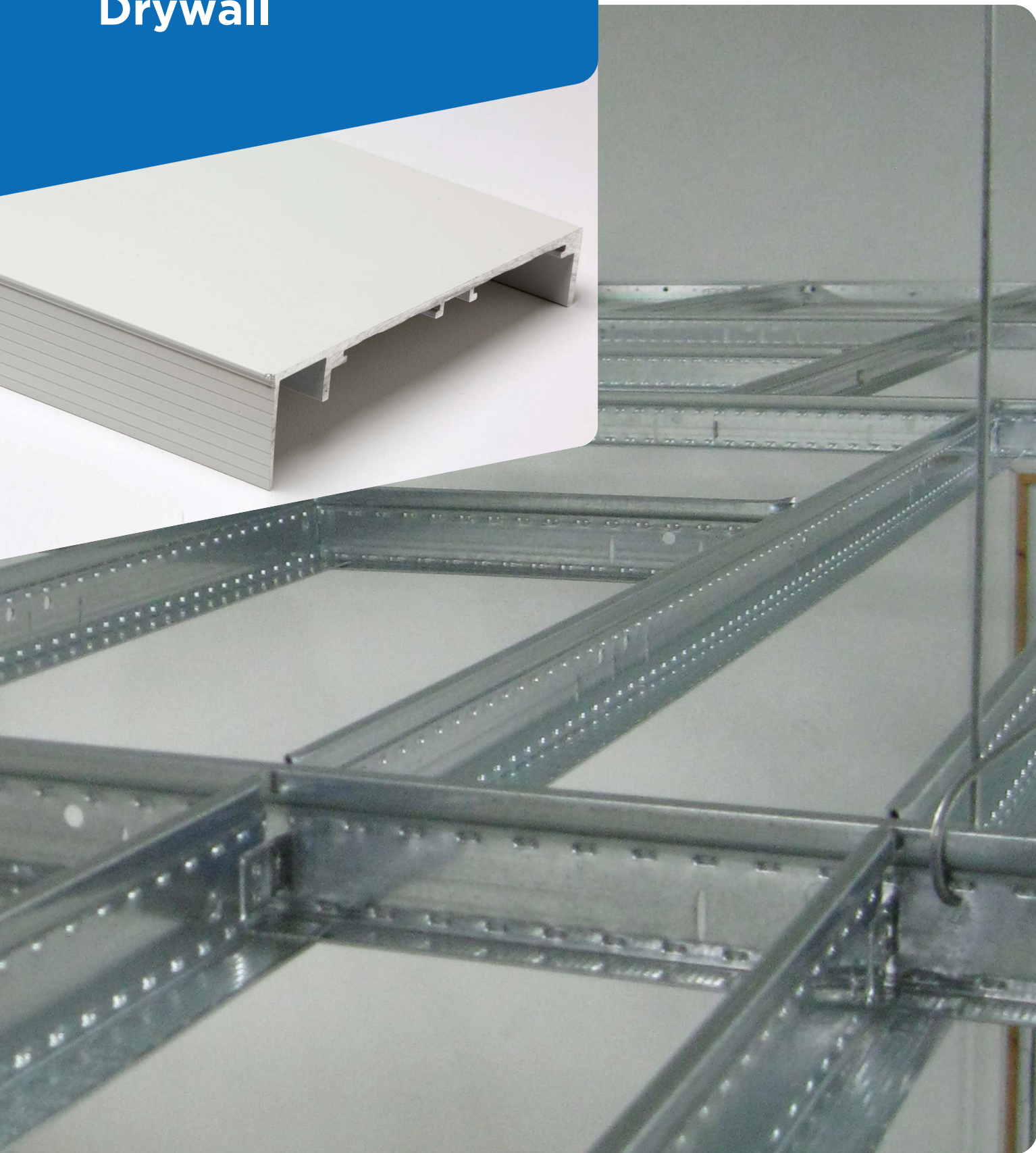



### General

CertainTeed Terminus Trim-Drywall is a perimeter trim system designed for use when installing a drywall cloud ceiling with CertainTeed 1-1/2" Drywall Suspension System.

The product is comprised of 10' long sections of trim, as well as inside and outside corner kits. The Terminus Trim-Drywall is available in heights ranging from 2"- 8". The product is extruded aluminum, and can be field cut using a standard sliding compound miter saw fitted with a carbide-tipped blade that is designed for cutting non-ferrous metals.

### Design & Specifications

The Terminus Trim-Drywall system is available in both straight and curved sections. The curved sections are limited to a 24" radius for a face-in product. Face-out curves are limited to a 48" radius.

All pieces include splices and twist clips for installation. Additional splices and twist clips available for order.

### Attachment

Steel splice plates are used to align and secure joints between sections of perimeter trim. For a 2" piece, each joint will require one splice plate; two splice plates for a 4" piece, three for a 6" piece and four for a 8" piece.

Terminus Twist Clips are connection clips that are used to securely attached the perimeter trim to the supporting suspension system members. These clips are supplied with each length of perimeter trim with a locking screw already factory installed. One clip is required for each intersection of suspension system and perimeter trim.

Drywall is fastened using standard drywall screws applied through the taping flange of the trim into the drywall suspension system.

After installation, the trim is finished using standard drywall materials and techniques. Once all taping and finishing is complete, the trim is to be painted to meet project requirements.

### Materials Required

- CertainTeed 1-1/2" Drywall Suspension System
- Terminus Trim
- Twist Clip assemblies
- Terminus Splice assemblies



Twist Clip

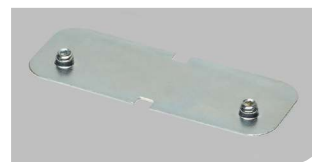

Splice Clip

# Installation Instructions - 12 Steps

## Step 1:

As with any suspended ceiling system, first determine the finished height of the assembly in accordance with the architectural details. Second, lay out and install the drywall suspension system according to the reflected ceiling plan. Determine the most appropriate layout for the suspension system that maximizes the length of the cross-tees that will terminate into the Terminus Trim-Drywall components.

## Step 2:

Brace and square the drywall suspension system. This can be achieved by bracing diagonally to the supporting structure above using splay wires, cut pieces of drywall suspension system, or "C" channels. Square the grid by either screwing or temporarily clamping a rigid bracing member such as a piece of main runner or wall angle, diagonally across the top of the drywall suspension system. This will allow the system to maintain proper 90 degree alignment between the main runners and cross-tees, and thus stay square.

## Step 3:

To determine the layout and positioning for the Terminus Trim-Drywall components, use the already installed drywall suspension system as a template for placement.

Temporarily assemble the components either on the floor or on top of the drywall suspension system, whichever is easier. Check the alignment of the components and clamp them in place.

With the components in place, mark the spots where the open side of the Terminus Trim-Drywall rests on the suspension system members.

Using the above reference mark as a guide, make an additional mark 1/2" to 5/8" closer to the inside face of the Terminus Trim Drywall. This second mark is where the suspension system members should be cut to fit inside the Terminus Trim Drywall components. The 1/2" dimension is the minimum dimension that the suspension components need to be inserted into the perimeter trim, with the 5/8" dimension being the maximum dimension capable. See **Fig. 1**

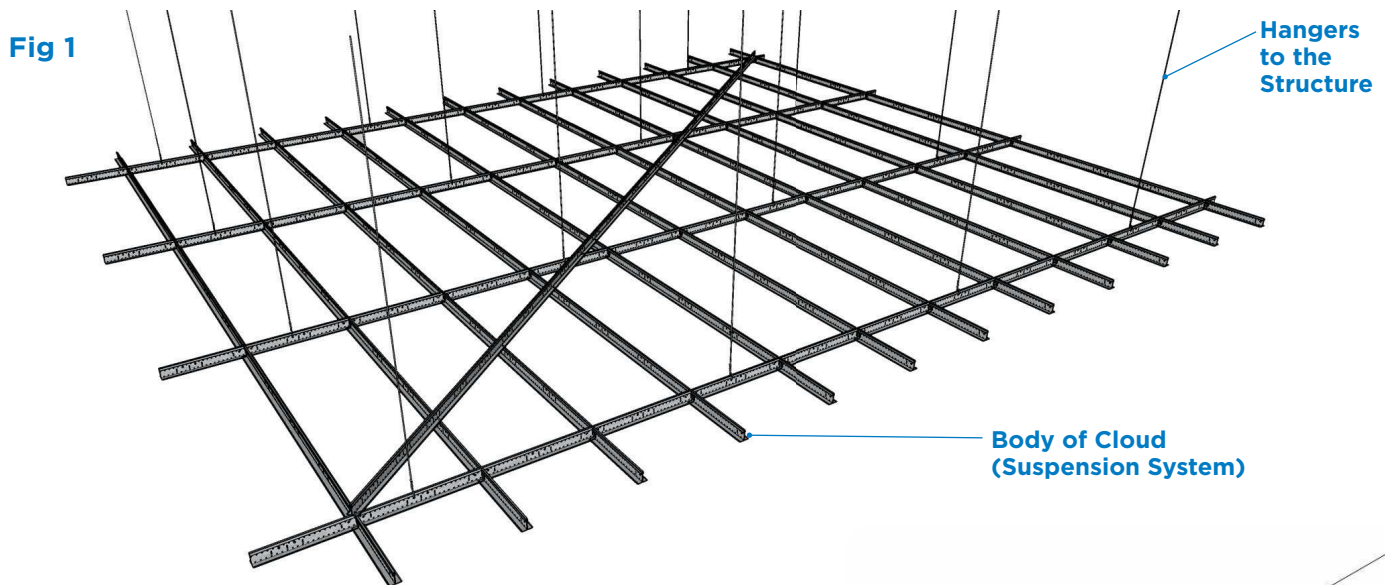

## Step 4:

Using the marks on the suspension system, cut the system to receive the Terminus Trim-Drywall components. Insert the twist clips into the Terminus Trim-Drywall channel to the approximately correct position. Hold up the perimeter trim to confirm that the clips align with the main runners and cross-tees [depending on which side is being worked on]. The twist clips are required to be installed at the terminal end of each cross-tee and main runner. Ensure that the maximum spacing between twist clips is 4-feet. Adjust the twist clip so that it is at the exact location of a cross-tee or main runner so that the clip fits under the bulb of the grid, and tight against the vertical webbing. Using a Phillips-head screw driver, tighten the screw on the twist clip to lock it in place. Do not over tighten the locking screw or it can come through and damage the face of the Terminus Trim. See **Fig. 2**

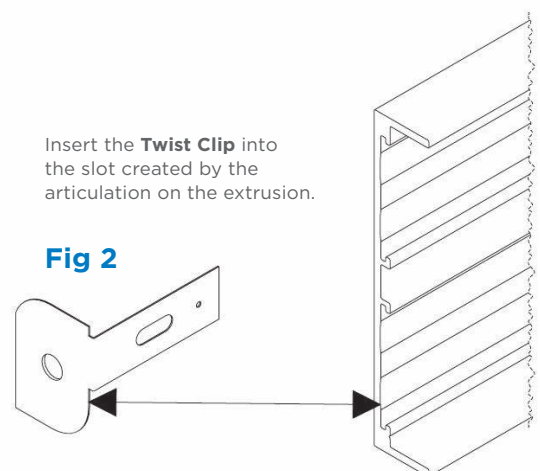

### Step 5:

Attach the Twist Clip by means of a screw or rivet into the web of the cross-tee or main runner.

### Step 6:

Connect up the next piece of Terminus Trim by inserting a Splice Clip into the first Terminus Trim and then shifting into the next piece of Terminus Trim. Tighten the screws as per the Twist Clip. Do not over tighten or this can come through and damage the face of the Terminus Trim. See **Fig. 3** (One Splice clip for 2" trim, two for 4", three for 6" and four for 8".)

Insert the **Splice Clip** into the slot created by the articulation on the extrusion.

**Fig 3**

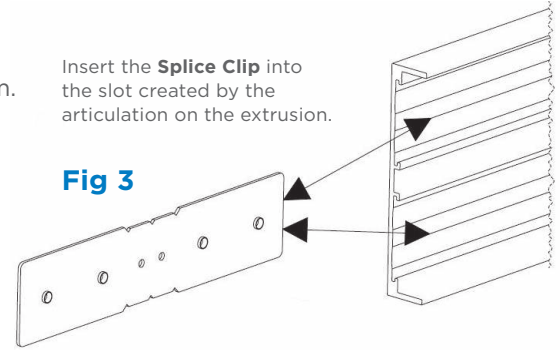

### Step 7:

Add additional hanger wires as required: The manufacturer requires that Terminus Trim systems and the associated supporting suspension systems be installed and supported in a manner that complies to all applicable codes and standards.

Main runners must be supported 4' on center or by calculation based on actual ceiling weight. Information on alternative hanger wire spacing to be found within ICC-ES ESR-3336.

Cross-tees located on either side of a joint in the Terminus Trim, and then at 4' centers must be supported by wires located closer to the perimeter trim than their midpoint.

Installations in seismic design areas may require additional seismic restraint. This may entail the addition of hanger wires to each suspension member within 8" of the terminal end. Lateral force bracing may be required, and should be consistent with locally approved standards, or as called out in the specifications.

### Step 8:

If the Terminus Trim is 6-inch or 8-inch, assess whether the Terminus requires additional support, either through the addition of bracing made from ceiling grid components, or support directly from the structure above.

### Step 9:

For corners, either use factory-mitered corners or bend the splice to the desired angle to receive the other piece of trim and field-miter cut.

### Step 10:

If the Terminus is comprised of curved trim (convex or concave), first lay out all the pieces on the floor to ensure they position correctly before commencing with the installation.

### Step 11:

Re-check all connections and splices to insure that every structural element has been appropriately installed.

### Step 12:

Attach 1/2" or 5/8" drywall to the completed suspension system and Terminus Trim, per the drywall manufacturer's recommendations. Lay out the position of the drywall panels to avoid having tapered edgings from falling at the location of the Terminus Trim. Finish and paint edges using standard materials and techniques.

