

AQUADRAIN® 18H

SUBSURFACE DRAINAGE COMPOSITE

DESCRIPTION

AQUADRAIN 18H drainage composite is a two-part prefabricated sheet drain consisting of a three-dimensional polypropylene formed dimple core covered with a heavy 8-oz. non-woven polypropylene filter fabric on one side. The formed dimple core provides compressive strength and collects water for flow to drainage discharge pipes. The filter fabric allows water or other liquids to pass into the drainage core while restricting the passage of soil particles. The filter fabric is bonded to each dimple to minimize fabric intrusion into the core resulting from backfill pressure. The polypropylene core resists chemical attack and degradation in soil.

APPLICATIONS

AQUADRAIN 18H is a cost-effective drainage sheet designed to replace or complement aggregate drainage backfills. It is designed primarily for horizontal applications over earth-covered structures or vertical applications when soils consist of a high percentage of fine particulate. AQUADRAIN 18H has a high compressive strength and high flow capacity. Applications include earth-covered structures and tunnels, foundation walls, retaining walls, bridge abutments, and planters. AQUADRAIN 18H can also function as a protection course when installed over a waterproofing membrane.

INSTALLATION

Install AQUADRAIN 18H with the plastic core toward the structure; filter fabric side outward toward direction of expected water flow. Product rolls may be installed horizontally or vertically oriented. For attaching the drainage composite to waterproofing membrane, concrete or wood, several methods may be used including washer-head fasteners, general construction adhesive, double-sided tape, wood lathing or insulation stick pin anchors. Discuss material compatibility with waterproofing supplier before using mechanical fasteners or adhesives. To attach drain sheet to bare earth, use 100mm-200mm (4"-8") soil anchor pins with washers.

For horizontal work, AQUADRAIN 18H may be loosely laid (with all edges abutted) directly over the waterproofing membrane. AQUADRAIN 18H must be secured if high winds are expected prior to the pour of concrete or placement of paver system. Install AQUADRAIN 18H with flange edge of the core at the higher side of the deck slope (away from the drain) so that the lapped flange edge sheds water like a roof shingle. Install subsequent AQUADRAIN 18H rolls with core edges abutting previous roll edges with flanged core edge side upstream (away from drain). This core flange position minimizes water seepage behind the drain core similar to the way roof shingles work. Secure filter fabric edge flap over roll lap joints with construction adhesive or duct tape. Cut drain composite as required to fit around penetrations and other details. Always seal open core edges with filter fabric flap or other applicable material including cut core edges around penetrations.

AQUADRAIN 18H should be used with proper drain discharges located throughout the deck area or sloped to drain at deck edge per specific project design. Minimize direct traffic on the drain composite until topping soil is in place. Do not drive vehicles directly on drainage composite prior to soil placement. Repair damaged or disrupted drainage system prior to topping soil placement. Product should not be left exposed to prolonged sunlight prior to topping soil placement.

AQUADRAIN 18H may be used for vertical applications. Install the bottom course of AQUADRAIN 18H with the bottom edge overlapping the top core flange edge of AQUADRAIN 100BD. (Refer to AQUADRAIN 100BD TechData Sheet for base drain installation instructions.) Position filter fabric flap from bottom of AQUADRAIN 18H over the front of AQUADRAIN 100BD and secure with adhesive or tape. Install subsequent AQUADRAIN 18H rolls with core edges abutting previous roll edges with core flange edge side upstream. Another installation technique is to simply overlap the drain sheet edges in a manner similar to the way roof shingles work

shedding water to the outside. Either method requires the filter fabric edge flap to cover roll lap joints and secured with construction adhesive or duct tape. Cut drain composite as required to fit around penetrations and other details. Always seal open core edges with filter fabric flap or other applicable material including cut core edges around penetrations.

Extend AQUADRAIN 18H installation to 150 mm (6") below the finished grade line. Wrap excess filter fabric flap behind the core edge at the top of the wall, and any system termination to prevent soil intrusion. Backfill with compacted soil directly against the filter fabric.

PACKAGING

AQUADRAIN 18H is available in 1.22 m x 15.85 m rolls (4' x 52') 208 sq ft per roll; individually packaged in a green plastic bag with white text.

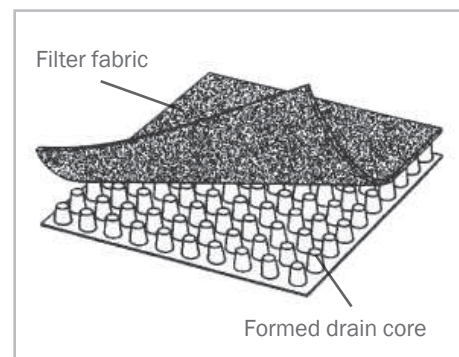

AQUADRAIN® 18H SUBSURFACE DRAINAGE COMPOSITE

TECHNICAL DATA

PROPERTY	TEST METHOD	TYPICAL VALUE	METRIC VALUE
NONWOVEN FILTER FABRIC PROPERTIES			
Material	N/A	Polypropylene	Polypropylene
Weight	ASTM D3776	8.0 oz/yd ²	270 g/m ²
Grab Tensile Strength	ASTM D4632	200 lbs.	0.9 kN
Puncture Strength	ASTM D3787	150 lbs.	0.68 kN
Trapezoidal Tear	ASTM D4533	105 lbs.	0.47 kN
Burst Strength	ASTM D3786	450 psi	3,100 Kpa
Elongation	ASTM D4632	50 percent	50 percent
Apparent Opening Size	ASTM D4751	70-100 U.S. std. sieve	0.15-0.21 mm
Permeability	ASTM D4491	0.30 cm/sec	0.30 cm/sec
Flow Rate	ASTM D4491	110 gpm/ft ²	4,475 l/min/m ²
DRAINAGE CORE PROPERTIES			
Material	N/A	Polypropylene	Polypropylene
Thickness	ASTM D1777	0.40 inch	10.1 mm
Compressive Strength	ASTM D1621 (mod)	18,000 lbs./ft ²	880 kPa
DRAINAGE COMPOSITE PROPERTIES			
Flow Capacity	ASTM D4716	16 gpm/ft. of width	201 l/min/m of width
Roll Length	N/A	52 ft.	15.8 m
Roll Width	N/A	4 ft.	1.22 m
Roll Weight	N/A	52 lbs.	23.6 kg

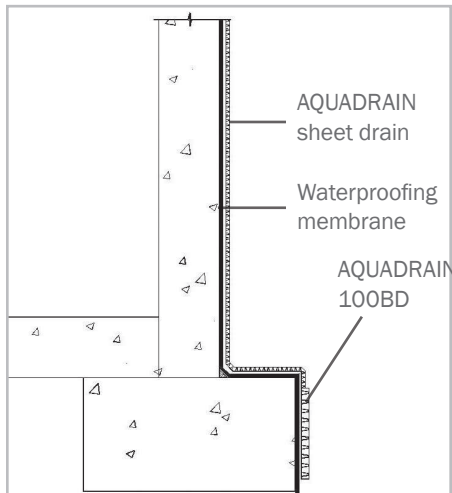

FOUNDATION WALL

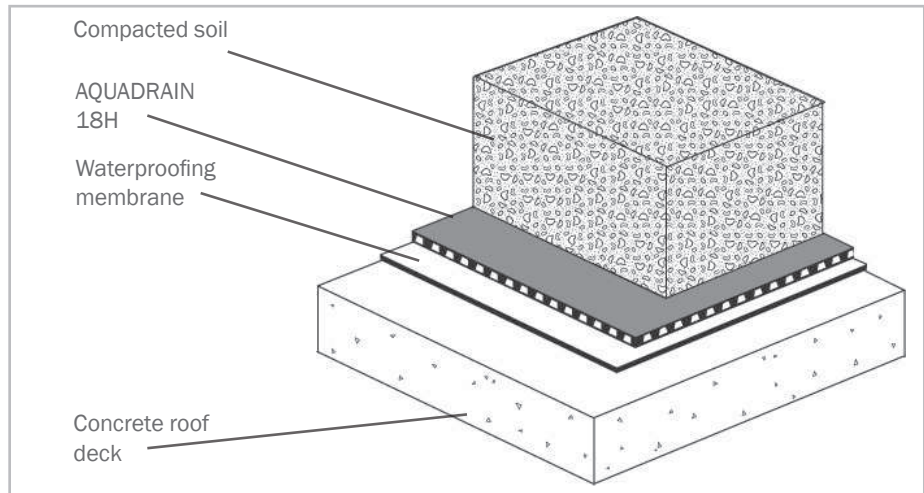

EARTH COVERED STRUCTURES

AQUADRAIN published flow performance and load values are determined by applicable industry testing methods. Specific project performance requirements and product selection should be determined by the project designer. Do not drive vehicles directly on drainage composite prior to concrete or backfill placement. Repair damaged or disrupted drainage system prior to backfill or cover material placement. Product should not be used as a surface material exposed to sunlight. AQUADRAIN is resistant to chemicals found in normal soil conditions. Additional geotextile filter fabric may be required for use around discharge pipes and other detailing.

North America: 847.851.1800 | 800.527.9948 | www.CETCO.com

UPDATED: JUNE 2015

© 2015 CETCO. IMPORTANT: The information contained herein supersedes all previous printed versions, and is believed to be accurate and reliable. For the most up-to-date information, please visit www.CETCO.com. CETCO accepts no responsibility for the results obtained through application of this product. All products are sold on the understanding that the user is solely responsible for determining their suitability for the intended use and for proper use and disposal of the product. CETCO MAKES NO WARRANTY OF MERCHANTABILITY OR SUITABILITY FOR ANY PARTICULAR PURPOSE IN CONNECTION WITH ANY SALE OF THE PRODUCTS DESCRIBED HEREIN. CETCO reserves the right to update information without notice.

