

HYDROFIX WATERPROOFING

HF-04

CONCRETE DECK

402-NH V02

Vertical or Horizontal Pipe Penetrations

SCALE: NTS 04/14

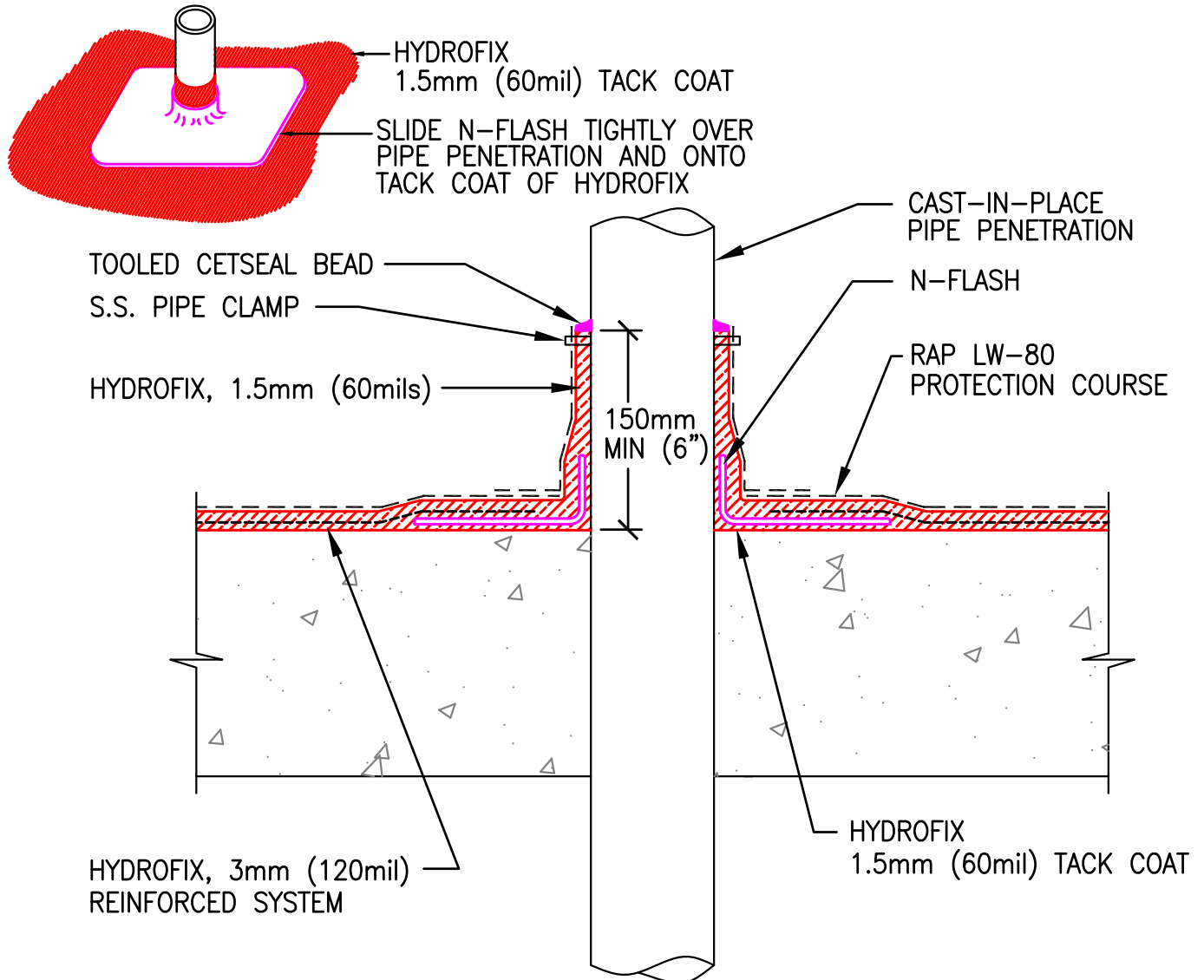

NOTE: CLEAN ALL PENETRATIONS OF DIRT, RUST AND OIL. ROUGHEN SURFACE OF PIPE BEFORE APPLYING HYDROFIX. VERIFY PENETRATION IS PROPERLY SECURED TO DECK OR WALL TO AVOID MOVEMENT OF PIPE.

This information is based on data and knowledge considered to be true and accurate. The information is offered for the users' consideration, verification, and requires project designer's approval before installation. CETCO does not warrant the results obtained and assumes no liability for the use of the information. CETCO waterproofing membranes are not intended to seal expansion joints; contact CETCO for expansion joint applications. This information is subject to change without notice.



2870 Forbs Avenue, Hoffman Estates, IL 60192 USA
tel 847.851.1800 fax (847) 851.1371 <http://www.cetco.com>
800.527.9948 email: field.services@cetco.com