

## Backer Bar 33mil (20 Gauge) Steel Backing System

The Backer Bar was specifically designed to meet the demand for the attachment of multiple items and heavier items to interior partitions. Provides superior connection shear and pullout strength for handrails, shelves and other wall fixtures.

Designed and patented by Bailey®. Manufactured, tested and distributed in the USA by ClarkDietrich®.

- Installs quickly and easily
- Available in 12", 16" and 24" spacing
- For use on non-structural and structural studs

### Product Data & Ordering Information:

Material:	50ksi yield strength
Coating:	G90
Thickness:	20ga STR (33mils), 0.0346" Design Thickness, 0.0329" Min. Thickness
Dimensions:	Leg: 1-1/4"
Width:	5"
Lengths:	for 12", 16" and 24" o.c. spacing

### Backer Bar Nominal Load Values:

Installation Condition	Nominal(lbs)
Shear / 0" Offset	2310
Shear / 1" Offset	805
Shear / 3" Offset	255
Tension	650

#### Load Table Notes:

1. Listed load values are nominal test load values, appropriate safety factors/resistance factors should be applied by the designer for calculating loads for intended use.
2. Shear / Offset (moment-rotation) Load refers to load directed in the plane of the wall.
3. Tension Load refers to load directed perpendicular to wall surface.
4. Tabulated loads include the contribution of 5/8" gypsum board.
5. Test loads were applied to the gypsum board and backing system through a 1/2" thick, 2-3/4" diameter steel plate secured w/(4) #12 hex head screws.
6. Loads were applied directly through the steel plate or to a steel rod that cantilevered from the plate.
7. Typical failure mode in backing testing was the gypsum board failure.
8. 24-in on-center stud spacing test results were similar/identical to 16-in on-center test results.
9. Listed capacities are based on 68mils (14ga) 50ksi studs.
10. Backer Bar is installed by bending the center tab along slotted holes inward to lay flush against outer face of metal stud web when installed. On the other end of the Backer Bar, bend small tabs along slotted holes outward to lay flush against inner face of metal stud web when installed. Secure the Backer Bar to the metal studs with (5) #8 wafer head/pan head screws at pre-punched holes in to flange of stud.

### ASTM & Code Standards:

- Structural framing is produced to meet or exceed ASTM C955
- Galvanized sheet steel meets or exceeds requirements of ASTM A1003
- SDS & Product Certification Information is available at [www.clarkdietrich.com/SupportDocs](http://www.clarkdietrich.com/SupportDocs)

### Sustainability Credits:

For more details and LEED letters contact Technical Services at 888-437-3244 or visit [www.clarkdietrich.com/LEED](http://www.clarkdietrich.com/LEED)

**LEED v4 MR Credit** -- Building Product Disclosure and Optimization: EPD (1 point) - Sourcing of Raw Materials (1 point) - Material Ingredients (1 point) - Construction and Demolition Waste Management (up to 2 points) - Innovation Credit (up to 2 points).

**LEED 2009 Credit MR 2 & MR 4** -- ClarkDietrich's steel products are 100% recyclable and have a national average recycled content of 34.2% (19.8% post-consumer and 14.4% pre-consumer). If seeking a higher number to meet Credit MR 5, please contact us at ([info@clarkdietrich.com](mailto:info@clarkdietrich.com) / 888-437-3244)

## 05.40.00 (Cold-Formed Metal Framing)

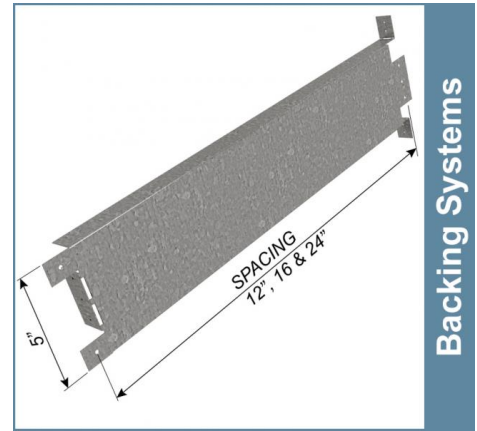

Backing Systems

### Typical Applications

- Wall-Mounted Televisions
- Hospital Handrails
- Towel and Shower Bars
- Cabinets and Shelves

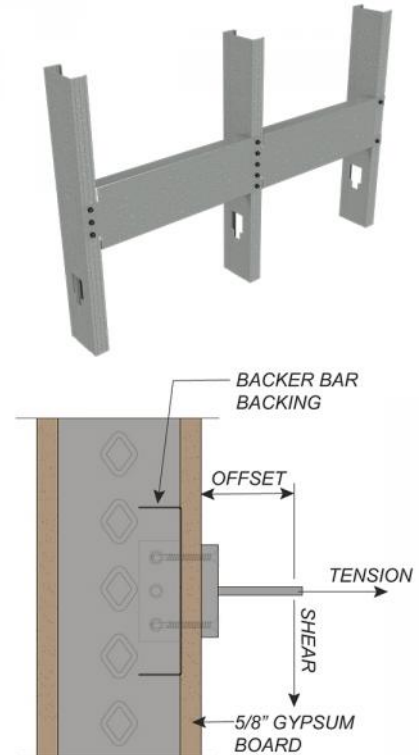

### Project Information

Name:  
Address:

### Contractor Information

Name:  
Contact:  
Phone:  
Fax:

### Architect Information

Name:  
Contact:  
Phone:  
Fax: