

Bridle Hanger

Attach floor joists to structural steel beams or wood ledgers.

Bridle hangers are commonly used to attach light-gauge C-joists to structural steel beams or wood ledgers. Connections can be made with screws, powder-actuated fasteners, drill-in concrete anchors or welding. Single- and double-wide bridle hangers are available.

PRODUCT DIMENSIONS

Widths: 2-1/16" or 4-1/8"

Heights: 6", 8", 10" or 12"

MATERIAL SPECIFICATIONS

Gauge: 14 gauge (68mil)

Design Thickness: 0.0713 inches

Gauge: 12 gauge (97mil)

Design Thickness: 0.1017 inches

Coating: G90

ASTM: A653/A653M

INSTALLATION

Attach bridle hanger to the primary frame as specified. When welding the hanger to the primary frame, a minimum of 2" fillet weld on each top flange is required. Distribute the weld equally on both top flanges. Uplift loads do not apply to weld-on applications. Special considerations must be taken when welding galvanized steel. Place joist into hanger and secure with fasteners. If bridle hanger is less than beam depth, provide back blocking.

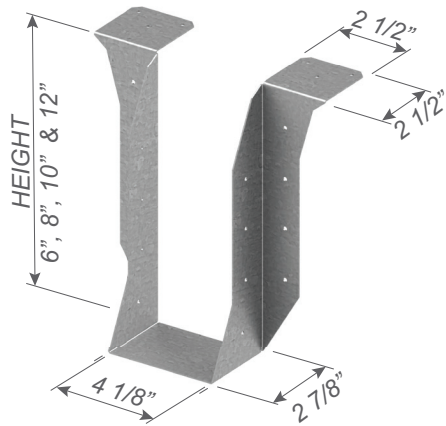
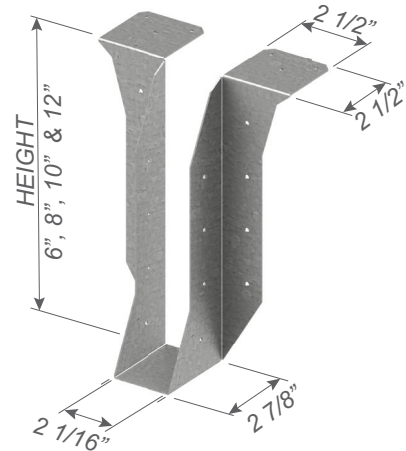

Bridle Hangers (CDBV, CDMB)

Product code	Thickness		Depth (H) (in)	Width (W) (in)	Packaging Pcs./Carton
	Mils (Gauge)	Design thickness (in)			
CDBV 1-5/8 x 6	68mil (14ga)	0.0713	6	1-5/8	20
CDBV 1-5/8 x 8			8		20
CDBV 1-5/8 x 10			10		15
CDBV 1-5/8 x 12			12		15
CDBV 2 x 6	68mil (14ga)	0.0713	6	2-1/16	20
CDBV 2 x 8			8		20
CDBV 2 x 10			10		15
CDBV 2 x 12			12		15
CDBV 4 x 6	68mil (14ga)	0.0713	6	4-1/8	15
CDBV 4 x 8			8		15
CDBV 4 x 10			10		15
CDBV 4 x 12			12		15
CDMB 1-5/8 x 6	97mil (12ga)	0.1017	6	1-5/8	20
CDMB 1-5/8 x 8			8		20
CDMB 1-5/8 x 10			10		15
CDMB 1-5/8 x 12			12		15
CDMB 2 x 6	97mil (12ga)	0.1017	6	2-1/16	20
CDMB 2 x 8			8		20
CDMB 2 x 10			10		15
CDMB 2 x 12			12		15
CDMB 4 x 6	97mil (12ga)	0.1017	6	4-1/8	15
CDMB 4 x 8			8		15
CDMB 4 x 10			10		15
CDMB 4 x 12			12		15

Bridle Hangers (CDBV, CDMB)

Product code	Member Designation (in)		Screw Configuration / Hanger				ASD Loads (lb)	
	Width	Height	Header		Joist	Uplift	Down	
			Flange	Web	Web			
CDBV 68mil (14ga)	1-11/16"	6	(6) #10	(4) #12	(2) #12	1146	1443	
		8	(6) #10	(6) #12	(3) #12	1929	2193	
		10	(6) #10	(8) #12	(4) #12	2314	2620	
		12	(6) #10	(10) #12	(5) #12	2873	3319	
		6	(4) x 2" fillet weld [each side of top flange]	(2) #12	-	1554		
		8		(3) #12	-	2089		
	10	(4) #12		-	2089			
	12	(5) #12		-	2089			
	2-1/16"	6	(6) #10	(4) #12	(2) #12	1146	1443	
		8	(6) #10	(6) #12	(3) #12	1929	2193	
		10	(6) #10	(8) #12	(4) #12	2314	2620	
		12	(6) #10	(10) #12	(5) #12	2873	3319	
		6	(4) x 2" fillet weld [each side of top flange]	(2) #12	-	1554		
		8		(3) #12	-	2089		
	10	(4) #12		-	2089			
	12	(5) #12		-	2089			
	4-1/8"	6	(6) #10	(4) #12	(4) #12	2293	2886	
		8	(6) #10	(6) #12	(6) #12	3699	4197	
		10	(6) #10	(8) #12	(8) #12	4629	5239	
		12	(6) #10	(10) #12	(10) #12	5025	6054	
		6	(4) x 2" fillet weld [each side of top flange]	(4) #12	-	3108		
		8		(6) #12	-	3771		
	10	(8) #12		-	5055			
	12	(10) #12		-	5104			
CDMB 97mil (12ga)	1-11/16"	6	(6) #10	(4) #14	(2) #14	1545	2032	
		8	(6) #10	(6) #14	(3) #14	2370	2687	
		10	(6) #10	(8) #14	(4) #14	3166	3474	
		12	(6) #10	(10) #14	(5) #14	3927	4950	
		6	(4) x 2" fillet weld [each side of top flange]	(2) #14	-	2032		
		8		(3) #14	-	2462		
	10	(4) #14		-	2993			
	12	(5) #14		-	2993			
	2-1/16"	6	(6) #10	(4) #14	(2) #14	1545	2032	
		8	(6) #10	(6) #14	(3) #14	2370	2687	
		10	(6) #10	(8) #14	(4) #14	3166	3474	
		12	(6) #10	(10) #14	(5) #14	3927	4950	
		6	(4) x 2" fillet weld [each side of top flange]	(2) #14	-	2032		
		8		(3) #14	-	2462		
	10	(4) #14		-	2993			
	12	(5) #14		-	2993			
	4-1/8"	6	(6) #10	(4) #14	(4) #14	3090	4064	
		8	(6) #10	(6) #14	(6) #14	4332	5558	
		10	(6) #10	(8) #14	(8) #14	6332	6949	
		12	(6) #10	(10) #14	(10) #14	7771	8948	
		6	(4) x 2" fillet weld [each side of top flange]	(4) #14	-	4064		
		8		(6) #14	-	4789		
	10	(8) #14		-	6078			
	12	(10) #14		-	6489			

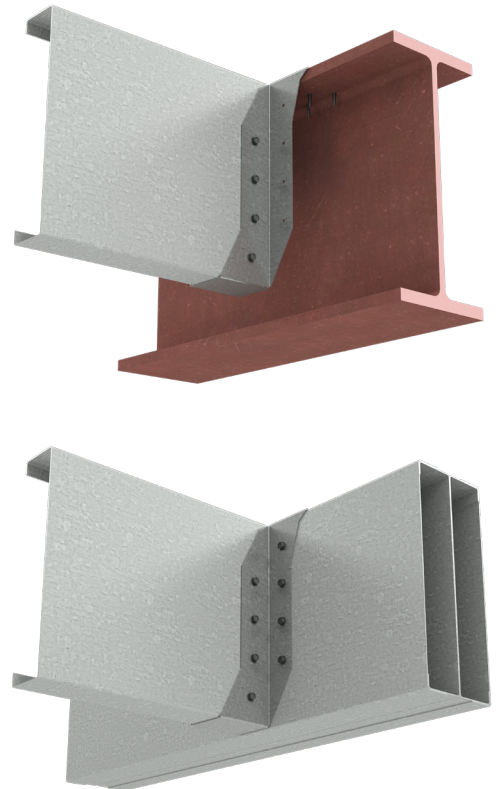

Notes:

- 1 Screws shall be installed through the pre-drilled holes in the hanger or as detailed by the designer.
- 2 CFS joist shall be laterally braced per designer specification.
- 3 An 1/8" gap shall be maintained between end of the joist and the supporting header.
- 4 CFS header must be braced to prevent web crippling/buckling per designer specification.
- 5 CFS header must have full bearing of 2-1/2" flange-depth.
- 6 The ultimate screw shear strength for #12 screws shall be at least 2330 lbs.
- 7 The ultimate screw shear strength for #14 screws shall be at least 3048 lbs.
- 8 The screw shear strength capacities are based on CFSEI Tech Note (F701-12).
- 9 Allowable loads have not been increased for seismic or wind.
- 10 Contact ClarkDietrich Engineering Services for technical assistance.