

## EasyClip™ X-Series™ Clip Angle

Secures U-channel (cold-rolled channel) framing members for lateral bridging, or secures one framing member to another for rigid connections.

ClarkDietrich EasyClip™ X-Series™ clip angles are used to secure U-channel to wall studs for lateral bridging. U-Channel is passed through the stud knockout and an EasyClip X-Series clip is screw attached or welded to provide a rigid connection. X-Series clip angles and U-channel should not be used in lateral bridging when stud width exceeds 6."

### ALTERNATIVE PRODUCTS

FastBridge™ Clip  
 EasyClip™ U-Series™ Clip Angle  
 EasyClip S-Series™ Support Clip  
 SwiftClip™ LS-Series™ Support Clip  
 Spazzer® 5400 and Spazzer® 9200 Spacer Bars

### PRODUCT DIMENSIONS

2" x 2" x 3-3/8"

2" x 2" x 5-3/4"

2" x 2" x 7-3/4"

2" x 2" x 9-3/4"

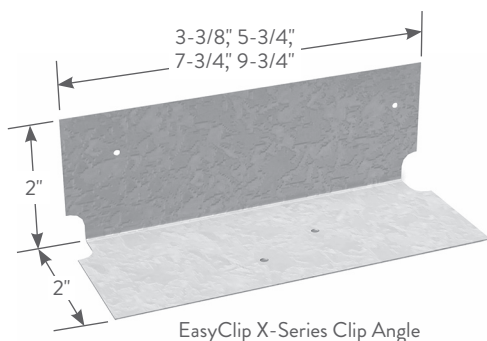

### MATERIAL SPECIFICATIONS

**Gauge:** 16 gauge (54mil)

**Design Thickness:** 0.0566 inches

**Gauge:** 14 gauge (68mil)

**Design Thickness:** 0.0713 inches

**Gauge:** 12 gauge (97mil)

**Design Thickness:** 0.1017 inches

**Coating:** G90

**Yield Strength:** 50ksi

**ASTM:** A653/A653M

### INSTALLATION

EasyClip X-Series Clip Angles are attached to cold-formed steel (CFS) framing members using #10 minimum self-drilling screws driven through the clip holes into the steel framing. Four pilot clip holes are provided and should be filled when this clip is used in a bridging application. This clip should not be more than 1/4" less in width than the cold-formed framing member.



## EasyClip™ X-Series™ Clip Angles

Product code	Thickness		Size (in)	Packaging Pcs./Bucket
	Mils (Gauge)	Design thickness (in)		
X543	54mil (16ga)	0.0566	2 x 2 x 3-3/8	200
X545	54mil (16ga)	0.0566	2 x 2 x 5-3/4	170
X547	54mil (16ga)	0.0566	2 x 2 x 7-3/4	100
X549	54mil (16ga)	0.0566	2 x 2 x 9-3/4	100
X683	68mil (14ga)	0.0713	2 x 2 x 3-3/8	200
X685	68mil (14ga)	0.0713	2 x 2 x 5-3/4	100
X687	68mil (14ga)	0.0713	2 x 2 x 7-3/4	100
X689	68mil (14ga)	0.0713	2 x 2 x 9-3/4	80
X973	97mil (12ga)	0.1017	2 x 2 x 3-3/8	100
X975	97mil (12ga)	0.1017	2 x 2 x 5-3/4	100
X977	97mil (12ga)	0.1017	2 x 2 x 7-3/4	60
X979	97mil (12ga)	0.1017	2 x 2 x 9-3/4	60

Typical Construction Details

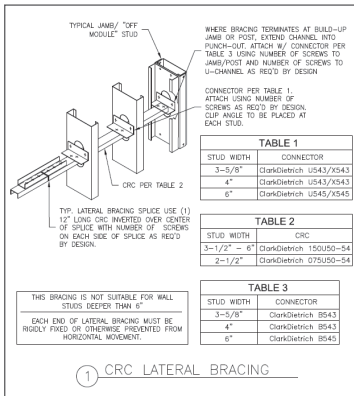

Visit our CAD Library at [clarkdietrich.com](http://clarkdietrich.com) to view or download construction details in .dwg, .dxf, and .pdf formats.

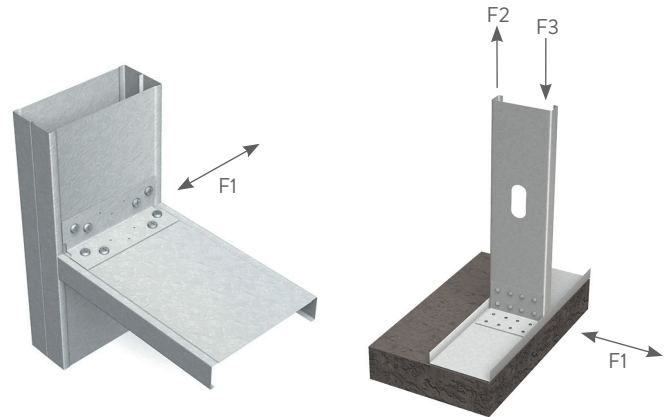

EasyClip™ X-Series™ Clip Angles Allowable Clip Capacities (lbs)

USING #10-16 SELF-DRILLING SCREWS

Product code	No. of screws to steel framing	Stud Thickness and Yield Strength								
		20ga (33mil) 33ksi			18ga (43mil) 33ksi			16ga (54mil) 50ksi		
		F1	F2	F3	F1	F2	F3	F1	F2	F3
X543	4	390 (390)	150 (531)	531	578 (578)	150 (788)	788	1028 (904)	150 (1400)	1400
	3	449 (449)	231 (531)	531	666 (666)	231 (788)	788	1184 (1184)	231 (1400)	1400
X545	5	677 (677)	231 (885)	885	1004 (1004)	231 (1313)	1313	1785 (1785)	231 (2333)	2333
	7	974 (974)	231 (1239)	1239	1445 (1445)	231 (1838)	1838	2568 (1810)	231 (2617)	3267
X547	5	761 (761)	311 (885)	885	1130 (1130)	311 (1313)	1313	2007 (2007)	311 (2333)	2333
	7	1031 (1031)	311 (1239)	1239	1529 (1529)	311 (1838)	1838	2718 (2718)	311 (3267)	3267
X549	9	1298 (1298)	311 (1593)	1593	1926 (1926)	311 (2363)	2363	3423 (2789)	311 (3527)	4200
	7	1102 (1102)	391 (1239)	1239	1635 (1635)	391 (1838)	1838	2905 (2905)	391 (3267)	3267
X549	9	1397 (1397)	391 (1593)	1593	2072 (2072)	391 (2363)	2363	3682 (3682)	391 (4200)	4200
	11	1690 (1690)	391 (1947)	1947	2508 (2508)	391 (2889)	2889	4457 (3779)	391 (4437)	5133
X683	4	390 (390)	238 (531)	531	578 (578)	238 (788)	788	1028 (1028)	238 (1400)	1400
X685	3	449 (449)	365 (531)	531	666 (666)	365 (788)	788	1184 (1184)	365 (1400)	1400
	5	677 (677)	365 (885)	885	1004 (1004)	365 (1313)	1313	1785 (1785)	365 (2333)	2333
X685	7	974 (974)	365 (1239)	1239	1445 (1445)	365 (1838)	1838	2568 (2278)	365 (3267)	3267
	5	761 (761)	492 (885)	885	1130 (1130)	492 (1313)	1313	2007 (2007)	492 (2333)	2333
X687	7	1031 (1031)	492 (1239)	1239	1529 (1529)	492 (1838)	1838	2718 (2718)	492 (3267)	3267
	9	1298 (1298)	492 (1593)	1593	1926 (1926)	492 (2363)	2363	3423 (3423)	492 (4200)	4200
X689	7	1102 (1102)	619 (1239)	1239	1635 (1635)	619 (1838)	1838	2905 (2905)	619 (3267)	3267
	9	1397 (1397)	619 (1593)	1593	2072 (2072)	619 (2363)	2363	3682 (3682)	619 (4200)	4200
X689	11	1690 (1690)	619 (1947)	1947	2508 (2508)	619 (2889)	2889	4457 (4457)	619 (5133)	5133
	4	390 (390)	485 (531)	531	578 (578)	485 (788)	788	1028 (1028)	485 (1400)	1400
X973	3	449 (449)	531 (531)	531	666 (666)	743 (788)	788	1184 (1184)	743 (1400)	1400
	5	677 (677)	743 (885)	885	1004 (1004)	743 (1313)	1313	1785 (1785)	743 (2333)	2333
X975	7	974 (974)	743 (1239)	1239	1445 (1445)	743 (1838)	1838	2568 (2568)	743 (3267)	3267
	5	761 (761)	885 (885)	885	1130 (1130)	1002 (1313)	1313	2007 (2007)	1002 (2333)	2333
X977	7	1031 (1031)	1002 (1239)	1239	1529 (1529)	1002 (1838)	1838	2718 (2718)	1002 (3267)	3267
	9	1298 (1298)	1002 (1593)	1593	1926 (1926)	1002 (2363)	2363	3423 (3423)	1002 (4200)	4200
X979	7	1102 (1102)	1239 (1239)	1239	1635 (1635)	1260 (1838)	1838	2905 (2905)	1260 (3267)	3267
	9	1397 (1397)	1260 (1593)	1593	2072 (2072)	1260 (2363)	2363	3682 (3682)	1260 (4200)	4200
X979	11	1690 (1690)	1260 (1947)	1947	2508 (2508)	1260 (2889)	2889	4457 (4457)	1260 (5133)	5133

Notes:

Screw Capacity Notes:

- The tabulated value indicates the number of screws in a single clip leg attached to the cold-formed steel (CFS) framing.
- Screws shall be attached in a symmetric manner starting at the top and bottom and moving toward the center.
- The allowable values for F1 are based only on the shear capacity of the clip leg attached to the CFS framing. The capacity of the attachment to other materials and structures must be checked separately.
- The allowable values for F2 assume mechanical fasteners are attached to the structure, and are located no more than 1" away from the angle bend. Mechanical fasteners to other materials and structures must be checked separately.
- This table is intended for use by qualified engineers only. It is the responsibility of the engineer to verify that the tabulated values apply to a specific connection application.
- When clips have combinations of F1, F2 and F3, use a linear interaction for combinations of F1 and F3, and a squared interaction for combinations of F1 and F2.

7 Allowable loads have not been increased 33% for wind or seismic.

8 For connections made to 14ga (68mil) and 12ga (97mil), use the tabulated values for 16ga (54mil), 50ksi.

9 It is the responsibility of the design professional to detail the drawings for proper clip attachment.

10 Contact ClarkDietrich Technical Services at 888-437-3244 for assistance.

Weld Capacity Notes:

- F1 and F2 values in parentheses are maximum shear and tension capacities when the clips are welded to the base structure (min 3/16" — 36ksi steel).
- Listed weld capacities are computed assuming an E70XX welding rod or wire.
- The clips are to be welded to the structure along the back corner along the complete length of the clip. When secondary welds are used to hold the clip in place, they are not used in capacity calculations.