

## RC-2 Pro™ Resilient Channel

### Double leg resilient channel

Made of 25 gauge steel (RC-2 Pro) is one of the most effective, low-cost methods of improving sound transmission loss through wood and steel frame partitions and ceilings. It is used as a cross-furring member for resilient attachment of gypsum. Knurled face makes wallboard application easier.

RC-2 Pro Double leg resilient channel is typically used for ceiling applications with multiple layers of gypsum board. Resilient channel should be installed perpendicular to the framing members. Channel is pre-punched for screw attachments to wood or steel framing members.

#### Product Data & Ordering Information:

Material: Grade 33ksi min. yield strength  
 Coating: G40EQ (G40 or G60 available)  
 Thickness: 25ga (18mils), 0.0188" Design Thickness, 0.0179" Min. Thickness  
 Dimensions: 2-1/2" x 1/2" Deep  
 Stock lengths: 12'-0" Long  
 Packaging weight: 290 lbs/1000 ft.

#### ASTM & Code Standards:

- Resilient channel is produced to meet or exceed ASTM C645
- Galvanized sheet steel meets or exceeds requirements of ASTM A924 & A1003
- For installation & storage information refer to ASTM C754
- SDS & Product Certification Information is available at [www.clarkdietrich.com/SupportDocs](http://www.clarkdietrich.com/SupportDocs)

#### RC-2 Pro STC Sound Assemblies:

Contact ClarkDietrich Technical Services at 888-437-3244 for STC values on this system.

#### Related Accessories:

- RC-1 Pro™ single leg resilient channel

### 09.22.16 (Non-Structural Metal Framing)

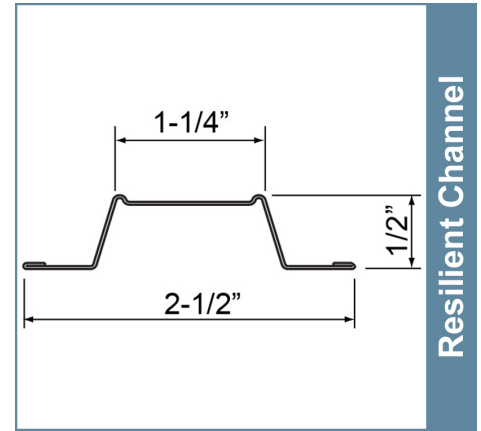

- Reduces sound transmissions
- Pre-punched for screws



#### Sustainability Credits:

For more details and LEED letters contact Technical Services at 888-437-3244 or visit [www.clarkdietrich.com/LEED](http://www.clarkdietrich.com/LEED)

**LEED v4 MR Credit** -- Building Product Disclosure and Optimization: EPD (1 point) - Sourcing of Raw Materials (1 point) - Material Ingredients (1 point) - Construction and Demolition Waste Management (up to 2 points) - Innovation Credit (up to 2 points).

**LEED 2009 Credit MR 2 & MR 4** -- ClarkDietrich's steel products are 100% recyclable and have a national average recycled content of 34.2% (19.8% post-consumer and 14.4% pre-consumer). If seeking a higher number to meet Credit MR 5, please contact us at ([info@clarkdietrich.com](mailto:info@clarkdietrich.com) / 888-437-3244)

#### Project Information

Name:  
Address:

#### Contractor Information

Name:  
Contact:  
Phone:  
Fax:

#### Architect Information

Name:  
Contact:  
Phone:  
Fax: