

RedHeader PRO™

RedHeader PRO™ can cut your labor time in half. It's designed to replace conventional boxed headers and built-up jambs and provide better results in half the time. One-piece headers and jambs eliminate the additional studs, track and screws required to frame conventional rough openings. Headers and jambs are also pre-cut to specified lengths to eliminate field cutting.

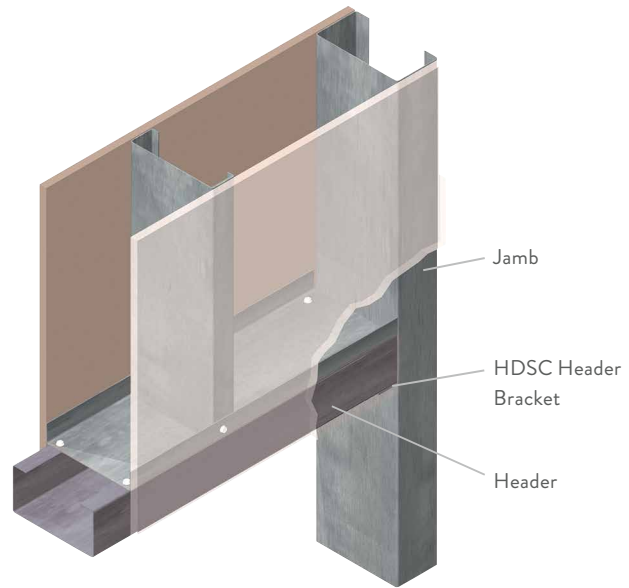

CONSTRUCTION ADVANTAGES:

- Eliminates built-up jambs and boxed or lay-in headers.
- Reduces material pieces and screws by up to 50%.
- The header easily slides into the HDSC Clip.
- Eliminates "capped" members, allowing drywall screws to drive through only one thickness of material.
- Header stud allows for easier fit of rigid insulation without additional cutting.
- Opened jamb stud does not require pre-insulating.
- SAVES LABOR in installation and handling!

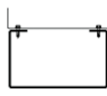
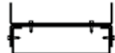
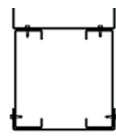

ORDERING INFORMATION:

- Pre-cut headers (4' 0" and over) available standard, based on minimum quantity orders.
- Minimum quantity orders of 30 headers required.
- HEADER LENGTHS SHOULD BE ORDERED 1/2" SHORTER THAN OPENING WIDTH TO FIT INSIDE CLIPS (header length = inside of jamb to inside of jamb minus 1/2").

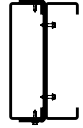
One RedHeader PRO	Replaces		One RedHeader PRO jamb stud	Replaces
				
(1) RedHeader with: (1) track for cripple attachments w/ (2) screws at 16" o.c.	Typical lay-in header with: (1) 1-5/8" flange stud & (2) tracks w/ (4) screws at 16" o.c.	Typical boxed header with: (2) 1-5/8" flange studs & (2) tracks w/ (4) screws at 16" o.c.	(1) RedHeader jamb stud: No track or screws required to build up sections	Typical jamb with: (2) 1-5/8" flange studs & (1) track w/ (4) screws at 16" o.c.