

**Product category:** PRO350 (3-1/2" flange RedHeader PRO) As Header  
**Product name:** **800PRO350-97 (50ksi, CP60) - Unpunched**  
 97mils (12ga) Coating: CP60 per ASTM C955

### Geometric Properties

Web depth	8.000 in	Design thickness	0.1017 in
Flange width	3.500 in	Min. steel thickness	0.0966 in
Stiffening lip	1.000 in	Yield strength, Fy	50 ksi

### Gross Section Properties of Full Section, Strong Axis

Cross sectional area (A)	1.652 in <sup>2</sup>
Member weight per foot of length	5.62 lb/ft
Moment of inertia (Ix)	16.741 in <sup>4</sup>
Section modulus (Sx)	4.185 in <sup>3</sup>
Radius of gyration (Rx)	3.183 in
Gross moment of inertia (Iy)	2.784 in <sup>4</sup>
Gross section modulus (Sy)	1.171 in <sup>3</sup>
Gross radius of gyration (Ry)	1.298 in

### Effective Section Properties, Strong Axis

Moment of inertia for deflection (Ixe)	16.738 in <sup>4</sup>
Moment of inertia for deflection (Iye*)	2.772 in <sup>4</sup>
Section modulus (Sxe)	3.786 in <sup>3</sup>
Section modulus (Sye*)	1.171 in <sup>3</sup>
Allowable bending moment (Max - Local)	113.35 in-k
Allowable bending moment (May - Local*)	40.41 in-k
Allowable bending moment (Max - Distortional)	108.71 in-k
Allowable bending moment (May - Distortional*)	30.42 in-k
Allowable shear force in web (Vax)	10885 lb

### Torsional Properties

St. Venant torsion constant (J x 1000)	5.696 in <sup>4</sup>
Warping constant (Cw)	38.834 in <sup>6</sup>
Distance from shear center to neutral axis (Xo)	-2.710 in
Radii of gyration (Ro)	4.378 in
Torsional flexural constant (Beta)	0.617

### Section Property Notes

\* Iye, Sye, and May are for a positive moment with the return lips in compression.  
 (Installing the header with the flanges pointing up)

### ASTM & Code Standards:

- AISI S100-12 and S100-07 w/S2-10 supplements
- Effective properties incorporate the strength increase from cold work of forming
- Structural framing is produced to meet or exceed ASTM C955
- Sheet steel meets or exceeds mechanical and chemical requirements of ASTM A1003
- SDS & Product Certification Information is available at [www.clarkdietrich.com](http://www.clarkdietrich.com)

### Sustainability Credits:

For more details and LEED letters contact Technical Services at 888-437-3244 or visit [www.clarkdietrich.com/LEED](http://www.clarkdietrich.com/LEED)

**LEED v4 MR Credit** -- Building Product Disclosure and Optimization: EPD (1 point) - Sourcing of Raw Materials (1 point) - Material Ingredients (1 point) - Construction and Demolition Waste Management (up to 2 points) - Innovation Credit (up to 2 points).

**LEED 2009 Credit MR 2 & MR 4** -- ClarkDietrich's steel products are 100% recyclable and have a national average recycled content of 34.2% (19.8% post-consumer and 14.4% pre-consumer). If seeking a higher number to meet Credit MR 5, please contact us at ([info@clarkdietrich.com](mailto:info@clarkdietrich.com) / 888-437-3244)

### 05.40.00 (Cold-Formed Metal Framing)

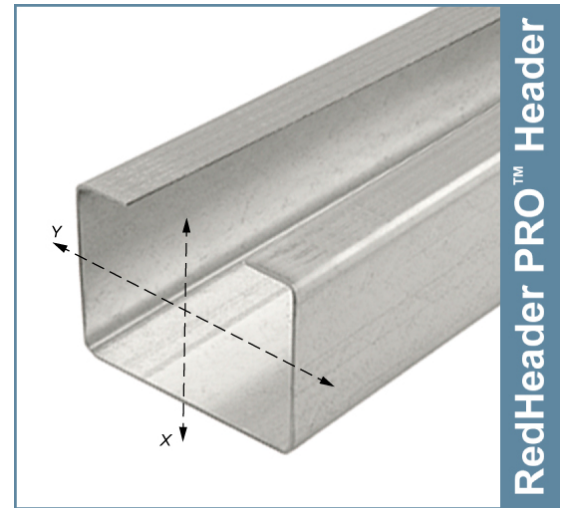

- Replaces lay-in and boxed headers.
- Reduces material pieces, weight & screws.
- Insulation installs quicker.

### Ordering Information:

Header lengths should be ordered 1/2" shorter to fit inside HDSC Header Brackets.  
 (Header length = inside of jamb to inside of jamb - 1/2")

### HDSC Header Bracket profile data:

See HDSC Header Bracket submittal sheet for allowable clip loads. All headers require the attachment of the HDSC Clip at each end with headers installed leg up.

### Project Information

Name:  
 Address:

### Contractor Information

Name:  
 Contact:  
 Phone:  
 Fax:

### Architect Information

Name:  
 Contact:  
 Phone:  
 Fax: