

## Uni-Clip™ End Clip

For numerous rigid framing connections and conditions, including two-axis loading, shear and tension.

ClarkDietrich's Uni-Clip™ end clip is a universal framing clip used to attach and support numerous rigid framing conditions. The Uni-Clip framing clip has a stiffened corner that provides superior design values. Embossed fastening patterns ensure easy, accurate placement of screws or powder-actuated fasteners. Designed to transfer large horizontal and vertical loads, this clip is ideal for most rigid connections, including shear, tension and two-axis loading.

### ALTERNATIVE PRODUCTS

- EasyClip™ D-Series™ Anchor Clip
- EasyClip T-Series™ Tall Anchor Clip
- EasyClip E-Series™ Support Clip
- Universal Bypass Clip

### PRODUCT DIMENSIONS

3-1/2" x 1-1/2" x 4-1/2"

### MATERIAL SPECIFICATIONS

- Gauge: 14 gauge (68mil)
- Design Thickness: 0.0713 inches
- Coating: G90
- Yield Strength: 50ksi
- ASTM: A653/A653M

### INSTALLATION

Uni-Clip end clips are attached to cold-formed steel framing members using #10 minimum self-drilling screws driven through the clip holes into the steel framing. Follow the required fastener and anchor placement patterns to achieve the allowable load. Connections to the primary building frame can be made with powder-actuated fasteners, screws or welds per design requirement.

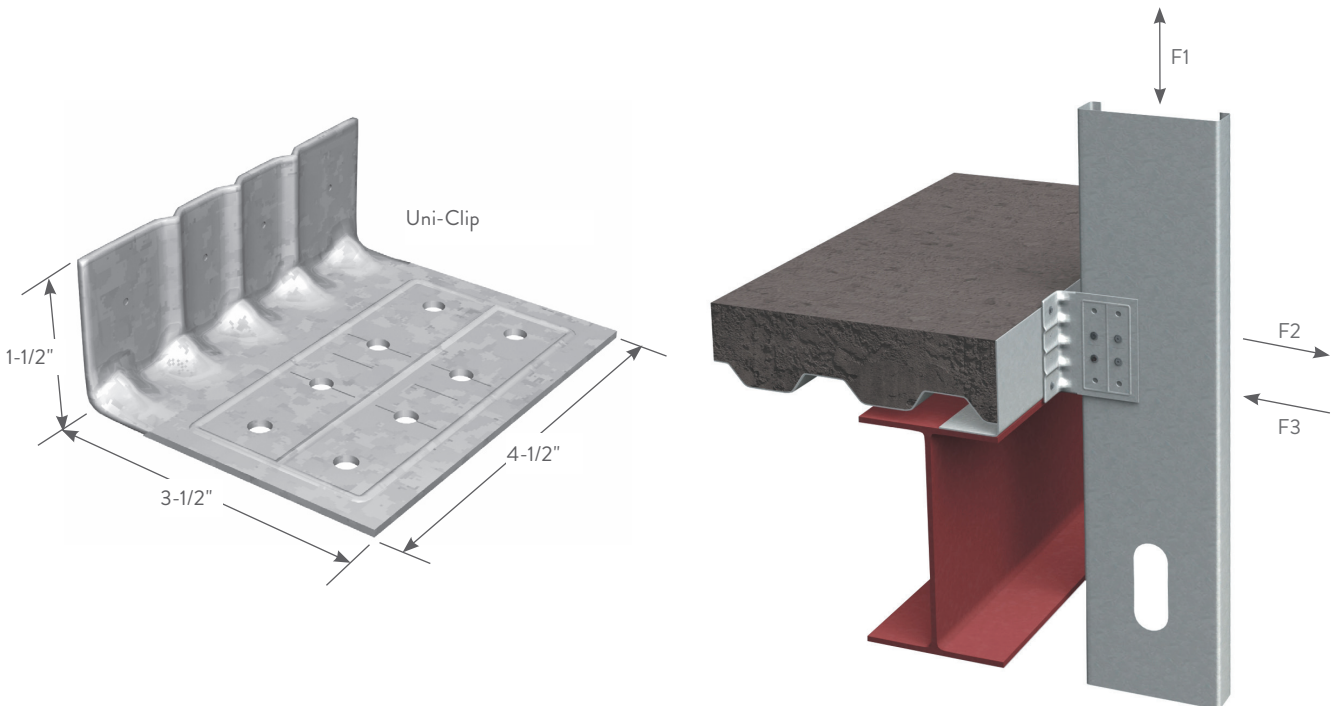

### Uni-Clip™ End Clip (UCEC)

Product code	Thickness		Size (in)	Packaging Pcs./Carton
	Mils (Gauge)	Design thickness (in)		
UCEC	68mil (14ga)	0.0713	3-1/2 x 1-1/2 x 4-1/2	25

U.S. Patent No. 6,688,069

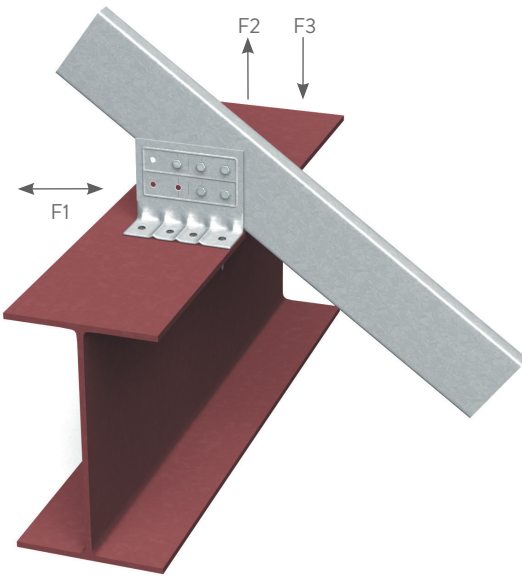

Location Options with (4) Screws



Option A

Option B

Option C

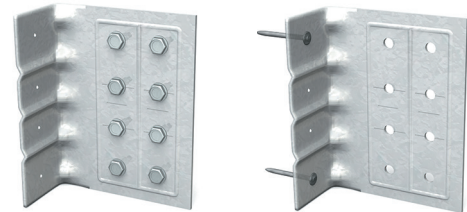

Location Options with (8) Screws

Location Options with (2) Anchors

### Uni-Clip™ (UCEC) Allowable Loads (lbs)

Anchor type	Stud thickness and yield strength	No. anchors to structure	Number/Configuration of Screws to Stud Framing											
			8 Screws			4 Screws (Option A)			4 Screws (Option B)			4 Screws (Option C)		
			F1	F2	F3	F1	F2	F3	F1	F2	F3	F1	F2	F3
Buildex #12-24 Tek 5 Self-Drilling Screws to 3/16" Steel	33mil (20ga) 33ksi	2	529	1121	1121	192	561	561	177	561	561	272	561	561
		3	529	1121	1121	192	561	561	177	561	561	272	561	561
		4	529	1121	1121	192	561	561	177	561	561	272	561	561
	43mil (18ga) 33ksi	2	784	1227	1664	285	832	832	263	832	832	404	832	832
		3	784	1664	1664	285	832	832	263	832	832	404	832	832
		4	784	1664	1664	285	832	832	263	832	832	404	832	832
	54mil (16ga) 33ksi	2	1105	1227	1889	402	920	1172	371	1172	1172	569	1172	1172
		3	1105	1841	1889	402	1172	1172	371	1172	1172	569	1172	1172
		4	1105	2345	1889	402	1172	1172	371	1172	1172	569	1172	1172
	54mil (16ga) 50ksi	2	1370	1227	1889	568	920	1417	523	1227	1209	804	1227	1655
		3	1560	1841	1889	568	1380	1417	523	1655	1209	804	1655	1655
		4	1560	2454	1889	568	1655	1417	523	1655	1209	804	1655	1655
PAF to 3/16" Steel*	33mil (20ga) 33ksi	2	529	511	1121	192	383	561	177	511	561	272	511	561
		3	529	767	1121	192	561	561	177	561	561	272	561	561
		4	529	1022	1121	192	561	561	177	561	561	272	561	561
	43mil (18ga) 33ksi	2	784	511	1664	285	383	832	263	511	832	404	511	832
		3	784	767	1664	285	575	832	263	767	832	404	767	832
		4	784	1022	1664	285	767	832	263	832	832	404	832	832
	54mil (16ga) 33ksi	2	1105	511	1889	402	383	1172	371	511	1172	569	511	1172
		3	1105	767	1889	402	575	1172	371	767	1172	569	767	1172
		4	1105	1022	1889	402	767	1172	371	1022	1172	569	1022	1172
	54mil (16ga) 50ksi	2	1117	511	1889	568	383	1417	523	511	1209	804	511	1655
		3	1560	767	1889	568	575	1417	523	767	1209	804	767	1655
		4	1560	1022	1889	568	767	1417	523	1022	1209	804	1022	1655

\*See General Note #6 on page 9 for the definition of PAF, minimum requirements and other additional information.

**Notes:**

- 1 The 1/3 stress increase for wind shall not be used.
- 2 Attach the Uni-Clip to the stud framing using Buildex #10-16 (min.) self-drilling screws.
- 3 When using 2 anchors, use the outermost marks on the short leg of the clips for anchor placement.
- 4 Attach building anchors to the structure according to the manufacturer's instructions. Anchors shall be installed through the embossments on the scored line of the 1-1/2" leg of the clip.
- 5 When using #12-24 for clips that have load combinations of F1, F2 and F3, use a linear interaction for combinations of F1 and F3, and a squared interaction for combinations of F1 and F2. When using PAFs, use a linear interaction for combinations of F1 and F3, and for combinations of F1 and F2.
- 6 Capacities listed for PAFs are based on minimum PAF requirements listed in General Note #6 on page 9.
- 7 It is the responsibility of the design professional to detail the project drawings for proper clip installation.
- 8 For connections to concrete, or other technical assistance, contact ClarkDietrich at 888-437-3244.
- 9 Buildex is a registered trademark of Illinois Tool Works Inc.

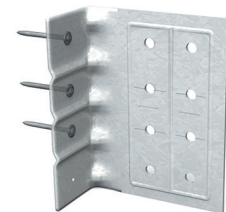

Location Options with (3) Anchors

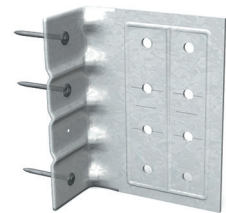

Location Options with (3) Anchors

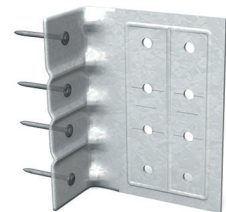

Location Options with (4) Anchors