

A27 and A27M Turnbuckle Form Aligners

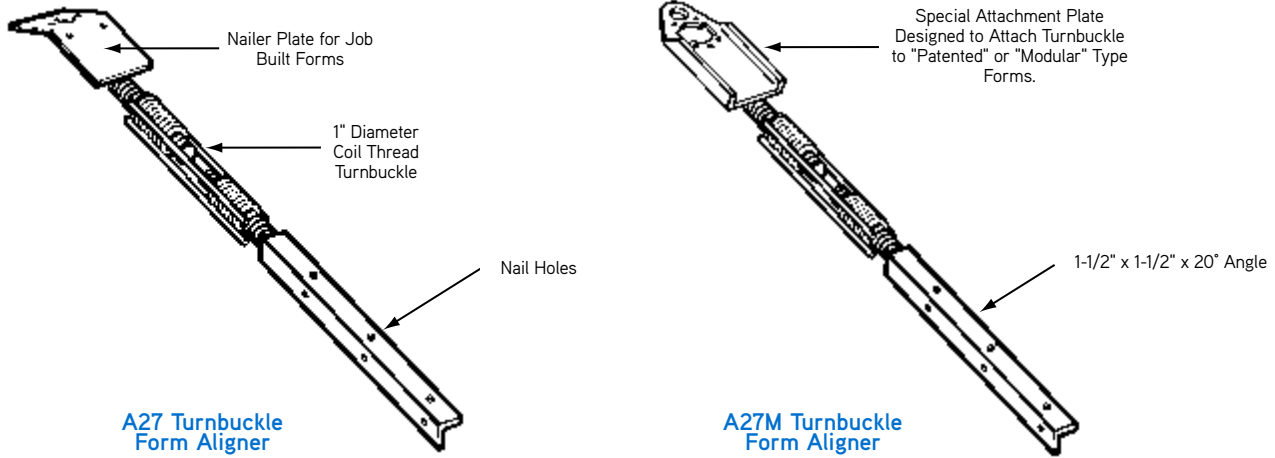

Light Forming Products

Dayton Superior A27 and A27M Turnbuckle Form Aligners are designed to accurately position and plumb vertical forms. The turnbuckle section of the aligner features a 1" diameter self-cleaning coil thread for fast adjustments. Overall length of the aligner is 37" minimum and 40" maximum, offering 3" of effective adjustment.

The A27 aligner has bent nailing plate equipped with nail holes and a 15/16" hole to accept 3/4" or 7/8" steel stakes. The A27M aligner has a special attachment plate that allows direct attachment to modular type forms. Both models are rugged units that offer high reuse and labor savings. The safe working load of the aligners is limited by the lumber, nailing and/or staking methods.

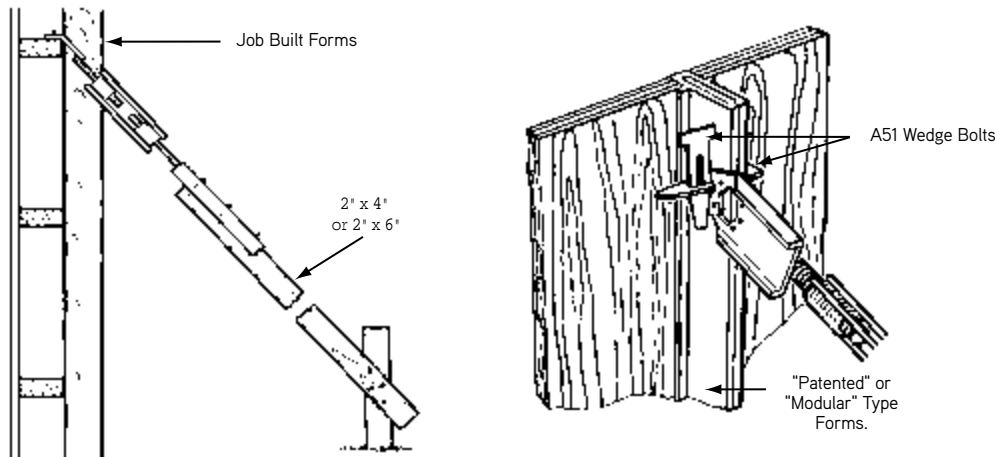

To Order:
Specify: (1) quantity, (2) name.

Example:
116 pcs.
A27 Turnbuckle Form Aligner.