

C24 Type 4-AP, 4-APR and 9 APR Pres-Steel Precast Half Hanger

The Dayton Superior C24 Pres-Steel Precast Half Hangers are available in three styles and capacities and are designed to be cast into the top portion of a precast/prestressed concrete girder. At the bridge site, these hangers are used to support the bridge overhang bracket, formwork, live load and dead load as well as the weight of a bridge deck finishing machine and/or concrete conveyer.

The bridge contractor must be certain of his bridge overhang bracket spacing before advising the precaster of the centers at which to install these hangers.

Install the C24 half hangers into the concrete maintaining the proper 1/8" setback from the edge of the girder. After the end of the strut wire is pushed into the fresh concrete, slightly vibrate the surrounding concrete so the strut wire is completely and solidly embedded into the concrete. The legs of the end clip must rest solidly on the top surface of the concrete.

An optional Bearing Plate can be welded beneath the end clip on Type 4-AP and 4-APR half hangers which will aid in spreading the hanger load to a wider area of concrete. Bearing Plates are generally required on half hangers used in girders having a flange thickness less than 5". For hanger modifications required for use with a flange thickness less than 5", please contact Technical Assistance. A Bearing Plate is standard on Type 9-APR half hangers.

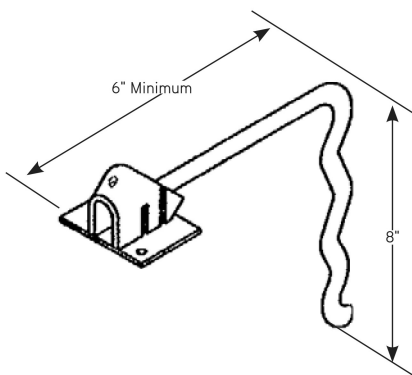
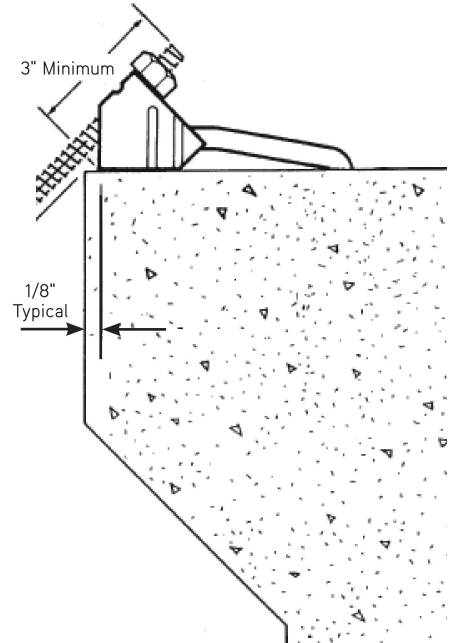

Type 4-AP
(For 1/2" diameter coil bolt)

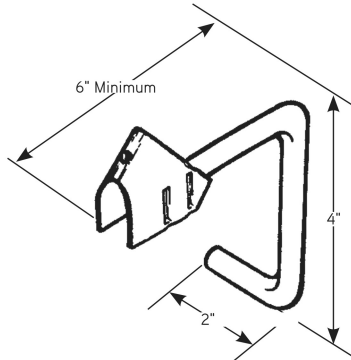

Type 4-APR
(For 1/2" diameter coil bolt)

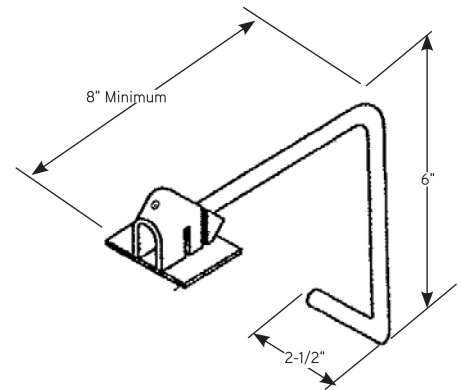

Type 9-APR
(For 3/4" diameter coil bolt)

Safe Working Load
 3,300 lbs. for 4-AP
 6,000 lbs. for 4-APR
 11,300 lbs. for 9-APR
 SWL provides a factor of safety of approximately 2 to 1.

To Order:
 Specify: (1) quantity, (2) name, (3) type, (4) strut length.
 Example:
 715 C24 Type 4-APR Pres-Steel Precast Half Hanger.

SAFETY NOTE:
 11,300 lbs. per side with B13H Coil Nuts
 SWL provides a factor of safety of approximately 2 to 1.