

## Bridge Overhang Bracket Type C89L

The C89L can be utilized on either steel or concrete girders using the appropriate 3/4" exterior hanger.

These brackets are fabricated with nail holes in the top of the horizontal member for securing the required lumber nailer to the bracket. Either a 6x2 or an 8x2 lumber member may be used as the nailer.

A guardrail receptacle, which allows for attaching a 2x4 guard rail post, is built into the outboard end of the bracket's horizontal member. The bracket can be easily and quickly preset on the ground and then set in place as needed. An outboard adjustment nut controls the vertical movement of the outboard end of the bracket to accommodate setting the overhang formwork to final grade.

The C89L Heavy Duty Bridge Overhang Bracket is designed for maximum adjustment and strength to meet the varied overhang forming requirements of the various State D.O.T.

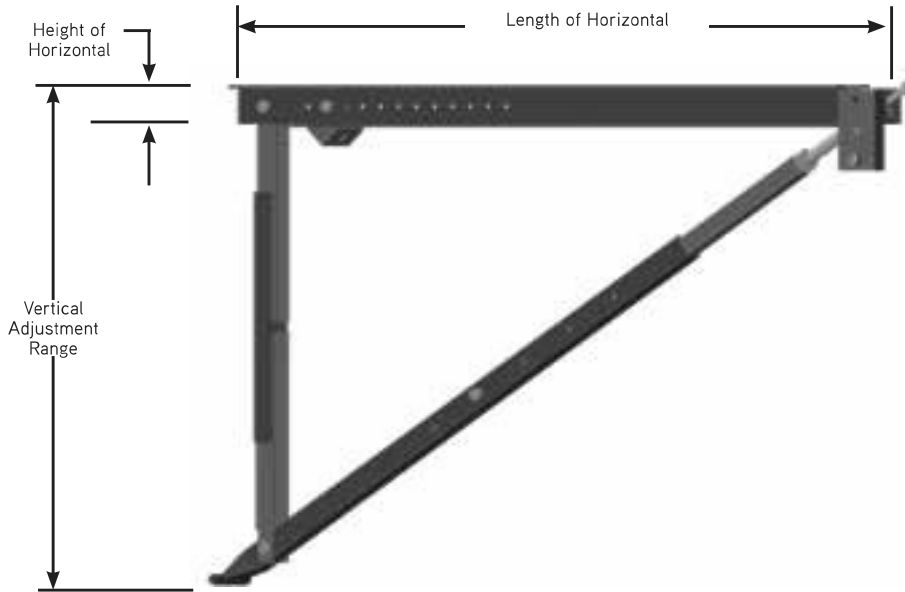

Bridge Overhang Brackets

Bracket Type	Length of Horizontal	Height of Horizontal	Range of Vertical Adjustment	Weight (lbs)
C89L	90"	6"	30" to 68"	159

Overhang brackets are usually adjusted to proper grade during the normal "dry run" operation. Typically, the overhang forms are set 1/4" to 3/8" above finished grade to compensate for dead load deflection.

### SAFETY NOTE:

DO NOT attempt an upward adjustment of the bracket during the concrete pouring operation. Lowering the bracket is permissible during the concrete pour.

## Bridge Overhang Bracket Type C89L

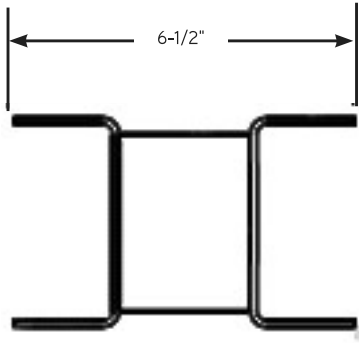

Section View  
Horizontal Member



The Product Code for the Bridge Overhang Bracket Type C89L is 1000123, and it weighs 159 lbs.

### Horizontal Channels

The horizontal member is fabricated from two back-to-back channels using 10 gauge carbon steel plate meeting the requirements of ASTM 1011, Grade 50 Class 1. This material has a minimum yield strength of 50 ksi and a minimum tensile strength of 65 ksi. The horizontal member of the C89L is 6" deep x 90" long.

### Vertical Leg

The vertical leg is made up of three channels, each channel is fabricated from 10 gauge carbon steel plate meeting the requirements of ASTM A1011, Grade 50 Class 1 having a minimum yield strength of 50 ksi and a minimum tensile strength of 65 ksi.

Part	Channel Leg	Channel Base
Vertical Leg Top Channel	2-1/4"	2-1/4"
Vertical Leg Extension Channel	1-15/16"	3-1/8"
Vertical Leg Bottom Channel	2-3/16"	2-13/16"

### Diagonal Leg

Square carbon steel tubing is used to fabricate the diagonal leg. The lower portion uses 2-1/2" and the upper portion uses 2" tubing. Both meet ASTM A500, Grade B requirements with a yield strength of 42 ksi and a ultimate tensile strength of 58 ksi. The diagonal leg of the C89L bracket has a SWL of 6,000 lbs. based on an approximate factor of safety of 2 to 1.

### Connection Bolts and Nuts

Connection bolts and nuts are Dayton Superior 3/4" diameter B14 Coil Bolts and two B13 Coil Nuts.

### C89L Horizontal Member Section Properties:

Section Modulus (S) = 4.438in<sup>3</sup>

Moment of Inertia (I) = 12.604 in<sup>4</sup>

Area (A) = 2.438 in<sup>2</sup>

## C89L Bolt Holder

The bolt holder used in the C89L brackets is designed to accept a 3/4" coil threaded bolt or coil rod and is the load carrying device that transfers the load from the overhang bracket to the 45° exterior bridge deck hanger.

The bolt holder can only be located at certain locations along the horizontal member of the bracket, based on the holes that have been factory punched in the side of the horizontal channels. These holes start at 2" from the inboard or beam end of the bracket and continue at 4", 6", 8", 10", 12", 14", 16", 18", 20", 22", 24" and 26" from the end of the bracket.

The Bolt Holder must be moved, for each specific project's situation, so the 3/4" diameter load carrying bolt is as close to a 45° angle with the top of the beam's flange as possible.

A bolt holder is shipped with each bracket.

### Adjusting to Grade

The "fine adjusting" screw at the end of the horizontal member allows the bracket to be easily adjusted to grade prior to loading.

To adjust the bracket, use a wrench on the 3/4"-10 UNC Heavy Hex Nut to raise or lower the bracket as needed.

### Guardrail Pocket

The build-in guardrail pocket is designed to accept a 2x4 guard rail post.

Please refer to the C49 Bridge Overhang Bracket section of this handbook for information on the OSHA requirements for guardrails.

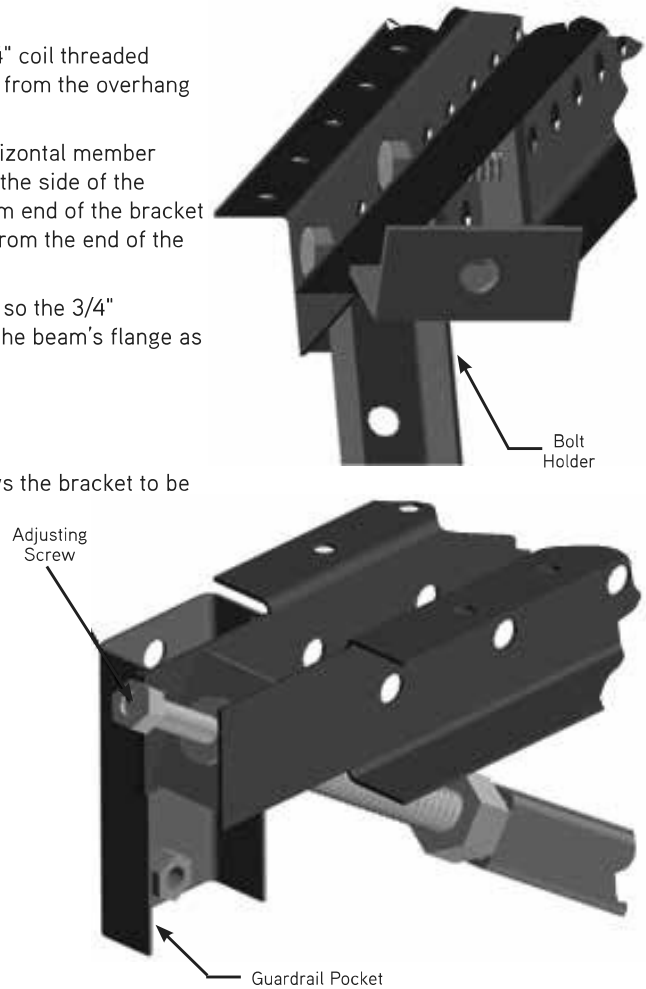

## C89L Bridge Overhang Bracket and Exterior Hanger Spacing

Over 1'-0" to 3'-0" Overhangs on Steel Beams or Girders

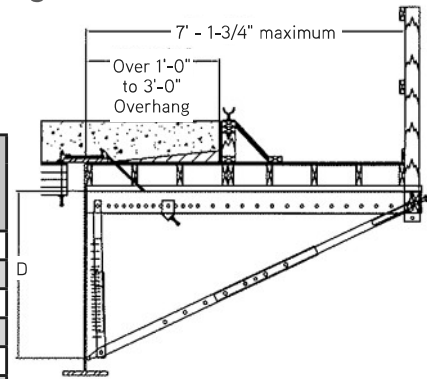

Bridge Overhang Brackets

Design Load PSF	Maximum Overhang Thickness	Bracket "D" Dimension	Screed Load Per Bracket = S1								Hanger SWL Range (lbs.)
			2,500 lbs.	2,250 lbs.	2,000 lbs.	1,750 lbs.	1,500 lbs.	1,250 lbs.	1,000 lbs.	0 lbs.	
130	6"	30"	4'-7"	5'-5"	5'-11"	6'-4"	6'-9"	7'-2"	7'-7"	8'-0"	8000
			4'-7"	5'-5"	6'-4"	7'-2"	8'-0"	8'-0"	8'-0"	8'-0"	11300
		45"	5'-2"	5'-6"	5'-11"	6'-4"	6'-9"	7'-2"	7'-7"	8'-0"	8000
			8'-0"	8'-0"	8'-0"	8'-0"	8'-0"	8'-0"	8'-0"	8'-0"	11300
		60"	5'-2"	5'-6"	5'-11"	6'-4"	6'-9"	7'-2"	7'-7"	8'-0"	8000
			8'-0"	8'-0"	8'-0"	8'-0"	8'-0"	8'-0"	8'-0"	8'-0"	11300
157	8"	30"	4'-5"	5'-0"	5'-4"	5'-9"	6'-1"	6'-6"	6'-10"	8'-0"	8000
			4'-5"	5'-3"	6'-1"	6'-11"	7'-9"	8'-0"	8'-0"	8'-0"	11300
		45"	4'-7"	5'-0"	5'-4"	5'-9"	6'-1"	6'-6"	6'-10"	8'-0"	8000
			8'-0"	8'-0"	8'-0"	8'-0"	8'-0"	8'-0"	8'-0"	8'-0"	11300
		60"	4'-7"	5'-0"	5'-4"	5'-9"	6'-1"	6'-6"	6'-10"	8'-0"	8000
			8'-0"	8'-0"	8'-0"	8'-0"	8'-0"	8'-0"	8'-0"	8'-0"	11300
184	10"	30"	4'-2"	4'-6"	4'-10"	5'-3"	5'-7"	5'-11"	6'-3"	7'-7"	8000
			4'-3"	5'-1"	5'-10"	6'-8"	7'-6"	8'-0"	8'-0"	8'-0"	11300
		45"	4'-2"	4'-6"	4'-10"	5'-3"	5'-7"	5'-11"	6'-3"	7'-7"	8000
			7'-4"	7'-8"	8'-0"	8'-0"	8'-0"	8'-0"	8'-0"	8'-0"	11300
		60"	4'-2"	4'-6"	4'-10"	5'-3"	5'-7"	5'-11"	6'-3"	7'-7"	8000
			7'-4"	7'-8"	8'-0"	8'-0"	8'-0"	8'-0"	8'-0"	8'-0"	11300
210	12"	30"	3'-10"	4'-2"	4'-6"	4'-9"	5'-1"	5'-5"	5'-8"	6'-11"	8000
			4'-1"	4'-10"	5'-7"	6'-4"	7'-2"	7'-11"	8'-0"	8'-0"	11300
		45"	3'-10"	4'-2"	4'-6"	4'-9"	5'-1"	5'-5"	5'-8"	6'-11"	8000
			6'-9"	7'-0"	7'-4"	7'-8"	8'-0"	8'-0"	8'-0"	8'-0"	11300
		60"	3'-10"	4'-2"	4'-6"	4'-9"	5'-1"	5'-5"	5'-8"	6'-11"	8000
			6'-9"	7'-0"	7'-4"	7'-8"	8'-0"	8'-0"	8'-0"	8'-0"	11300
237	14"	30"	3'-7"	3'-10"	4'-2"	4'-5"	4'-8"	5'-0"	5'-3"	6'-5"	8000
			3'-10"	4'-7"	5'-4"	6'-1"	6'-9"	7'-6"	7'-11"	8'-0"	11300
		45"	3'-7"	3'-10"	4'-2"	4'-5"	4'-8"	5'-0"	5'-3"	6'-5"	8000
			6'-3"	6'-6"	6'-9"	7'-1"	7'-4"	7'-8"	7'-11"	8'-0"	11300
		60"	3'-7"	3'-10"	4'-2"	4'-5"	4'-8"	5'-0"	5'-3"	6'-5"	8000
			6'-3"	6'-6"	6'-9"	7'-1"	7'-4"	7'-8"	7'-11"	8'-0"	11300
264	16"	30"	3'-4"	3'-7"	3'-10"	4'-1"	4'-4"	4'-8"	4'-11"	5'-11"	8000
			3'-8"	4'-4"	5'-0"	5'-8"	6'-5"	7'-1"	7'-4"	8'-0"	11300
		45"	3'-4"	3'-7"	3'-10"	4'-1"	4'-4"	4'-8"	4'-11"	5'-11"	8000
			5'-9"	6'-0"	6'-4"	6'-7"	6'-10"	7'-1"	7'-4"	8'-0"	11300
		60"	3'-4"	3'-7"	3'-10"	4'-1"	4'-4"	4'-8"	4'-11"	5'-11"	8000
			5'-9"	6'-0"	6'-4"	6'-7"	6'-10"	7'-1"	7'-4"	8'-0"	11300
290	18"	30"	3'-1"	3'-4"	3'-7"	3'-10"	4'-1"	4'-4"	4'-7"	5'-7"	8000
			3'-5"	4'-1"	4'-8"	5'-4"	6'-0"	6'-8"	6'-11"	7'-10"	11300
		45"	3'-1"	3'-4"	3'-7"	3'-10"	4'-1"	4'-4"	4'-7"	5'-7"	8000
			5'-5"	5'-8"	5'-11"	6'-2"	6'-5"	6'-8"	6'-11"	7'-10"	11300
		60"	3'-1"	3'-4"	3'-7"	3'-10"	4'-1"	4'-4"	4'-7"	5'-7"	8000
			5'-5"	5'-8"	5'-11"	6'-2"	6'-5"	6'-8"	6'-11"	7'-10"	11300
317	20"	30"	2'-11"	3'-1"	3'-4"	3'-7"	3'-10"	4'-1"	4'-3"	5'-3"	8000
			3'-2"	3'-10"	4'-5"	5'-0"	5'-7"	6'-3"	6'-5"	7'-5"	11300
		45"	2'-11"	3'-1"	3'-4"	3'-7"	3'-10"	4'-1"	4'-3"	5'-3"	8000
			5'-1"	5'-3"	5'-6"	5'-9"	6'-0"	6'-3"	6'-5"	7'-5"	11300
		60"	2'-11"	3'-1"	3'-4"	3'-7"	3'-10"	4'-1"	4'-3"	5'-3"	8000
			5'-1"	5'-3"	5'-6"	5'-9"	6'-0"	6'-3"	6'-5"	7'-5"	11300

**NOTES:**

- Design load calculations for the above bracket spacings are based on a dead load of 160 pcf for the concrete and formwork, a live load of 50 psf for workers, moveable equipment and materials, plus a 75 plf vertical load applied at the outside edge of the deck overhang. A 50 psf live load is also applied to the walkway area.
- Always check overhang form lumber to make certain it will span the selected bracket spacing.
- For a nominal charge, Dayton Superior Technical Assistance will calculate a recommended bracket spacing when conditions on your specific project vary from those shown.

## C89L Bridge Overhang Bracket and Exterior Hanger Spacing

Over 3'-0" To 4'-0" Overhangs on Steel Beams or Girders

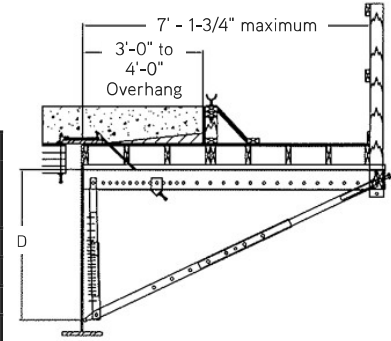

Design Load PSF	Maximum Overhang Thickness	Bracket "D" Dimension	Screed Load Per Bracket = S <sub>t</sub>								Hanger SWL Range (lbs.)
			2,500 lbs.	2,250 lbs.	2,000 lbs.	1,750 lbs.	1,500 lbs.	1,250 lbs.	1,000 lbs.	0 lbs.	
130	6"	30"	1'-6"	2'-5"	3'-4"	4'-3"	5'-2"	6'-1"	6'-8"	8'-0"	8000
			1'-6"	2'-5"	3'-4"	4'-3"	5'-2"	6'-1"	7'-0"	8'-0"	11300
		45"	4'-6"	4'-11"	5'-3"	5'-7"	6'-0"	6'-4"	6'-8"	8'-0"	8000
			6'-9"	7'-8"	8'-0"	8'-0"	8'-0"	8'-0"	8'-0"	8'-0"	11300
		60"	4'-6"	4'-11"	5'-3"	5'-7"	6'-0"	6'-4"	6'-8"	8'-0"	8000
			7'-11"	8'-0"	8'-0"	8'-0"	8'-0"	8'-0"	8'-0"	8'-0"	11300
157	8"	30"	1'-5"	2'-3"	3'-2"	4'-0"	4'-10"	5'-7"	5'-11"	7'-2"	8000
			1'-5"	2'-3"	3'-2"	4'-0"	4'-10"	5'-8"	6'-6"	8'-0"	11300
		45"	4'-0"	4'-4"	4'-7"	4'-11"	5'-3"	5'-7"	5'-11"	7'-2"	8000
			6'-4"	7'-2"	7'-7"	7'-11"	8'-0"	8'-0"	8'-0"	8'-0"	11300
		60"	4'-0"	4'-4"	4'-7"	4'-11"	5'-3"	5'-7"	5'-11"	7'-2"	8000
			7'-0"	7'-3"	7'-7"	7'-11"	8'-0"	8'-0"	8'-0"	8'-0"	11300
184	10"	30"	1'-4"	2'-1"	2'-11"	3'-8"	4'-6"	5'-0"	5'-3"	6'-5"	8000
			1'-4"	2'-1"	2'-11"	3'-8"	4'-6"	5'-3"	6'-1"	8'-0"	11300
		45"	3'-7"	3'-10"	4'-2"	4'-5"	4'-8"	5'-0"	5'-3"	6'-5"	8000
			5'-11"	6'-6"	6'-9"	7'-1"	7'-4"	7'-8"	7'-11"	8'-0"	11300
		60"	3'-7"	3'-10"	4'-2"	4'-5"	4'-8"	5'-0"	5'-3"	6'-5"	8000
			6'-3"	6'-6"	6'-9"	7'-1"	7'-4"	7'-8"	7'-11"	8'-0"	11300
210	12"	30"	1'-3"	2'-0"	2'-8"	3'-5"	4'-2"	4'-6"	4'-9"	5'-9"	8000
			1'-3"	2'-0"	2'-8"	3'-5"	4'-2"	4'-11"	5'-8"	8'-0"	11300
		45"	3'-3"	3'-6"	3'-9"	4'-0"	4'-3"	4'-6"	4'-9"	5'-9"	8000
			5'-6"	5'-10"	6'-2"	6'-5"	6'-8"	6'-11"	7'-2"	8'-0"	11300
		60"	3'-3"	3'-6"	3'-9"	4'-0"	4'-3"	4'-6"	4'-9"	5'-9"	8000
			5'-7"	5'-10"	6'-2"	6'-5"	6'-8"	6'-11"	7'-2"	8'-0"	11300
237	14"	30"	1'-2"	1'-10"	2'-6"	3'-2"	3'-10"	4'-1"	4'-4"	5'-3"	8000
			1'-2"	1'-10"	2'-6"	3'-2"	3'-11"	4'-7"	5'-3"	7'-6"	11300
		45"	2'-11"	3'-2"	3'-5"	3'-8"	3'-10"	4'-1"	4'-4"	5'-3"	8000
			5'-1"	5'-4"	5'-7"	5'-10"	6'-1"	6'-4"	6'-6"	7'-6"	11300
		60"	2'-11"	3'-2"	3'-5"	3'-8"	3'-10"	4'-1"	4'-4"	5'-3"	8000
			5'-1"	5'-4"	5'-7"	5'-10"	6'-1"	6'-4"	6'-6"	7'-6"	11300
264	16"	30"	1'-1"	1'-8"	2'-4"	3'-0"	3'-7"	3'-9"	4'-0"	4'-10"	8000
			1'-1"	1'-8"	2'-4"	3'-0"	3'-7"	4'-3"	4'-11"	6'-10"	11300
		45"	2'-8"	2'-11"	3'-1"	3'-4"	3'-7"	3'-9"	4'-0"	4'-10"	8000
			4'-8"	4'-11"	5'-2"	5'-4"	5'-7"	5'-9"	6'-0"	6'-10"	11300
		60"	2'-8"	2'-11"	3'-1"	3'-4"	3'-7"	3'-9"	4'-0"	4'-10"	8000
			4'-8"	4'-11"	5'-2"	5'-4"	5'-7"	5'-9"	6'-0"	6'-10"	11300
290	18"	30"	1'-0"	1'-7"	2'-2"	2'-9"	3'-3"	3'-6"	3'-8"	4'-6"	8000
			1'-0"	1'-7"	2'-2"	2'-9"	3'-4"	3'-11"	4'-6"	6'-4"	11300
		45"	2'-6"	2'-8"	2'-11"	3'-1"	3'-3"	3'-6"	3'-8"	4'-6"	8000
			4'-4"	4'-7"	4'-9"	4'-11"	5'-2"	5'-4"	5'-7"	6'-4"	11300
		60"	2'-6"	2'-8"	2'-11"	3'-1"	3'-3"	3'-6"	3'-8"	4'-6"	8000
			4'-4"	4'-7"	4'-9"	4'-11"	5'-2"	5'-4"	5'-7"	6'-4"	11300
317	20"	30"	*	1'-5"	2'-0"	2'-7"	3'-1"	3'-3"	3'-5"	4'-2"	8000
			*	1'-5"	2'-0"	2'-7"	3'-1"	3'-8"	4'-2"	5'-11"	11300
		45"	2'-4"	2'-6"	2'-8"	2'-10"	3'-1"	3'-3"	3'-5"	4'-2"	8000
			4'-1"	4'-3"	4'-5"	4'-7"	4'-9"	5'-0"	5'-2"	5'-11"	11300
		60"	2'-4"	2'-6"	2'-8"	2'-10"	3'-1"	3'-3"	3'-5"	4'-2"	8000
			4'-1"	4'-3"	4'-5"	4'-7"	4'-9"	5'-0"	5'-2"	5'-11"	11300

**NOTES:**

- Design load calculations for the above bracket spacings are based on a dead load of 160 pcf for the concrete and formwork, a live load of 50 psf for workers, moveable equipment and materials, plus a 75 plf vertical load applied at the outside edge of the deck overhang. A 50 psf live load is also applied to the walkway area.
- Always check overhang form lumber to make certain it will span the selected bracket spacing.
- For a nominal charge, Dayton Superior Technical Assistance will calculate a recommended bracket spacing when conditions on your specific project vary from those shown.

## C89L Bridge Overhang Bracket and Exterior Hanger Spacing

Over 4'-0" To 5'-0" Overhangs on Steel Beams or Girders

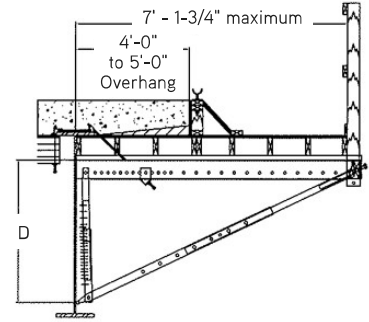

Bridge Overhang Brackets

Design Load PSF	Maximum Overhang Thickness	Bracket "D" Dimension	Screed Load Per Bracket = S <sub>1</sub>							Hanger SWL Range (lbs.)	
			2,500 lbs.	2,250 lbs.	2,000 lbs.	1,750 lbs.	1,500 lbs.	1,250 lbs.	1,000 lbs.		0 lbs.
130	6"	30"	*	*	1'-3"	2'-2"	3'-1"	3'-11"	4'-10"	7'-4"	8000
			*	*	1'-3"	2'-2"	3'-1"	3'-11"	4'-10"	8'-0"	11300
		45"	3'-8"	4'-5"	4'-8"	5'-0"	5'-4"	5'-8"	6'-0"	7'-4"	8000
			3'-8"	4'-7"	5'-5"	6'-4"	7'-3"	8'-0"	8'-0"	8'-0"	11300
		60"	4'-1"	4'-5"	4'-8"	5'-0"	5'-4"	5'-8"	6'-0"	7'-4"	8000
			7'-1"	7'-5"	7'-9"	8'-0"	8'-0"	8'-0"	8'-0"	8'-0"	11300
157	8"	30"	*	*	1'-2"	1'-11"	2'-9"	3'-7"	4'-4"	6'-4"	8000
			*	*	1'-2"	1'-11"	2'-9"	3'-7"	4'-4"	7'-7"	11300
		45"	3'-4"	3'-9"	4'-1"	4'-4"	4'-8"	4'-11"	5'-2"	6'-4"	8000
			3'-4"	4'-1"	4'-11"	5'-8"	6'-6"	7'-4"	7'-10"	8'-0"	11300
		60"	3'-6"	3'-9"	4'-1"	4'-4"	4'-8"	4'-11"	5'-2"	6'-4"	8000
			6'-1"	6'-5"	6'-8"	7'-0"	7'-3"	7'-6"	7'-10"	8'-0"	11300
184	10"	30"	*	*	1'-1"	1'-9"	2'-6"	3'-3"	3'-11"	5'-7"	8000
			*	*	1'-1"	1'-9"	2'-6"	3'-3"	3'-11"	6'-10"	11300
		45"	3'-0"	3'-4"	3'-7"	3'-10"	4'-1"	4'-4"	4'-7"	5'-7"	8000
			3'-0"	3'-9"	4'-5"	5'-2"	5'-11"	6'-7"	6'-11"	7'-10"	11300
		60"	3'-1"	3'-4"	3'-7"	3'-10"	4'-1"	4'-4"	4'-7"	5'-7"	8000
			5'-5"	5'-8"	5'-11"	6'-2"	6'-5"	6'-8"	6'-11"	7'-10"	11300
210	12"	30"	*	*	*	1'-7"	2'-3"	2'-11"	3'-7"	5'-0"	8000
			*	*	*	1'-7"	2'-3"	2'-11"	3'-7"	6'-3"	11300
		45"	2'-9"	3'-0"	3'-2"	3'-5"	3'-8"	3'-10"	4'-1"	5'-0"	8000
			2'-9"	3'-4"	4'-0"	4'-8"	5'-4"	5'-11"	6'-2"	7'-0"	11300
		60"	2'-9"	3'-0"	3'-2"	3'-5"	3'-8"	3'-10"	4'-1"	5'-0"	8000
			4'-10"	5'-0"	5'-3"	5'-6"	5'-8"	5'-11"	6'-2"	7'-0"	11300
237	14"	30"	*	*	*	1'-6"	2'-1"	2'-8"	3'-3"	4'-6"	8000
			*	*	*	1'-6"	2'-1"	2'-8"	3'-3"	5'-8"	11300
		45"	2'-6"	2'-8"	2'-11"	3'-1"	3'-3"	3'-6"	3'-8"	4'-6"	8000
			2'-6"	3'-1"	3'-8"	4'-3"	4'-11"	5'-4"	5'-7"	6'-4"	11300
		60"	2'-6"	2'-8"	2'-11"	3'-1"	3'-3"	3'-6"	3'-8"	4'-6"	8000
			4'-4"	4'-7"	4'-9"	4'-11"	5'-2"	5'-4"	5'-7"	6'-4"	11300
264	16"	30"	*	*	*	1'-4"	1'-11"	2'-5"	3'-0"	4'-1"	8000
			*	*	*	1'-4"	1'-11"	2'-5"	3'-0"	5'-3"	11300
		45"	2'-3"	2'-5"	2'-8"	2'-10"	3'-0"	3'-2"	3'-4"	4'-1"	8000
			2'-3"	2'-10"	3'-5"	3'-11"	4'-6"	4'-11"	5'-1"	5'-9"	11300
		60"	2'-3"	2'-5"	2'-8"	2'-10"	3'-0"	3'-2"	3'-4"	4'-1"	8000
			4'-0"	4'-2"	4'-4"	4'-6"	4'-8"	4'-11"	5'-1"	5'-9"	11300
290	18"	30"	*	*	*	1'-3"	1'-9"	2'-3"	2'-9"	3'-9"	8000
			*	*	*	1'-3"	1'-9"	2'-3"	2'-9"	4'-10"	11300
		45"	2'-1"	2'-3"	2'-5"	2'-7"	2'-9"	2'-11"	3'-1"	3'-9"	8000
			2'-1"	2'-7"	3'-1"	3'-7"	4'-1"	4'-6"	4'-8"	5'-4"	11300
		60"	2'-1"	2'-3"	2'-5"	2'-7"	2'-9"	2'-11"	3'-1"	3'-9"	8000
			3'-8"	3'-10"	4'-0"	4'-2"	4'-4"	4'-6"	4'-8"	5'-4"	11300
317	20"	30"	*	*	*	1'-2"	1'-7"	2'-1"	2'-6"	3'-6"	8000
			*	*	*	1'-2"	1'-7"	2'-1"	2'-6"	4'-5"	11300
		45"	1'-11"	2'-1"	2'-3"	2'-5"	2'-6"	2'-8"	2'-10"	3'-6"	8000
			1'-11"	2'-5"	2'-10"	3'-4"	3'-10"	4'-2"	4'-4"	4'-11"	11300
		60"	1'-11"	2'-1"	2'-3"	2'-5"	2'-6"	2'-8"	2'-10"	3'-6"	8000
			3'-4"	3'-6"	3'-8"	3'-10"	4'-0"	4'-2"	4'-4"	4'-11"	11300

**NOTES:**

- Design load calculations for the above bracket spacings are based on a dead load of 160 pcf for the concrete and formwork, a live load of 50 psf for workers, moveable equipment and materials, plus a 75 plf vertical load applied at the outside edge of the deck overhang. A 50 psf live load is also applied to the walkway area.
- Always check overhang form lumber to make certain it will span the selected bracket spacing.
- For a nominal charge, Dayton Superior Technical Assistance will calculate a recommended bracket spacing when conditions on your specific project vary from those shown.

## C89L Bridge Overhang Bracket and Exterior Hanger Spacing

Over 1'-0" to 3'-0" Overhangs on Precast/Prestressed Concrete Girders

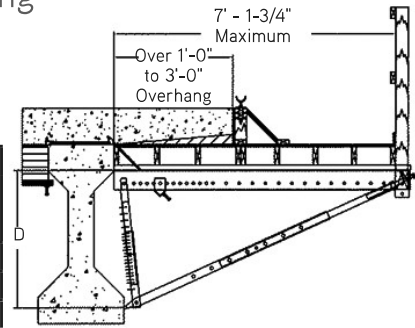

Design Load PSF	Maximum Overhang Thickness	Bracket "D" Dimension	Screed Load Per Bracket = S <sub>i</sub>								Hanger SWL Range (lbs.)
			2,500 lbs.	2,250 lbs.	2,000 lbs.	1,750 lbs.	1,500 lbs.	1,250 lbs.	1,000 lbs.	0 lbs.	
130	6"	30"	3'-7"	4'-3"	5'-0"	5'-8"	6'-1"	6'-6"	6'-10"	8'-0"	8000
			3'-7"	4'-3"	5'-0"	5'-8"	6'-4"	7'-0"	7'-8"	8'-0"	11300
		45"	4'-8"	5'-0"	5'-4"	5'-9"	6'-1"	6'-6"	6'-10"	8'-0"	8000
			8'-0"	8'-0"	8'-0"	8'-0"	8'-0"	8'-0"	8'-0"	8'-0"	11300
		60"	4'-8"	5'-0"	5'-4"	5'-9"	6'-1"	6'-6"	6'-10"	8'-0"	8000
			8'-0"	8'-0"	8'-0"	8'-0"	8'-0"	8'-0"	8'-0"	8'-0"	11300
157	8"	30"	3'-5"	4'-1"	4'-9"	5'-2"	5'-6"	5'-9"	6'-1"	7'-5"	8000
			3'-5"	4'-1"	4'-9"	5'-5"	6'-1"	6'-9"	7'-4"	8'-0"	11300
		45"	4'-2"	4'-6"	4'-10"	5'-2"	5'-6"	5'-9"	6'-1"	7'-5"	8000
			7'-3"	7'-7"	7'-11"	8'-0"	8'-0"	8'-0"	8'-0"	8'-0"	11300
		60"	4'-2"	4'-6"	4'-10"	5'-2"	5'-6"	5'-9"	6'-1"	7'-5"	8000
			7'-3"	7'-7"	7'-11"	8'-0"	8'-0"	8'-0"	8'-0"	8'-0"	11300
184	10"	30"	3'-3"	3'-11"	4'-4"	4'-8"	4'-11"	5'-3"	5'-6"	6'-9"	8000
			3'-3"	3'-11"	4'-6"	5'-2"	5'-9"	6'-5"	7'-0"	8'-0"	11300
		45"	3'-9"	4'-0"	4'-4"	4'-8"	4'-11"	5'-3"	5'-6"	6'-9"	8000
			6'-6"	6'-10"	7'-2"	7'-5"	7'-9"	8'-0"	8'-0"	8'-0"	11300
		60"	3'-9"	4'-0"	4'-4"	4'-8"	4'-11"	5'-3"	5'-6"	6'-9"	8000
			6'-6"	6'-10"	7'-2"	7'-5"	7'-9"	8'-0"	8'-0"	8'-0"	11300
210	12"	30"	3'-1"	3'-8"	3'-11"	4'-3"	4'-6"	4'-9"	5'-1"	6'-2"	8000
			3'-1"	3'-8"	4'-3"	4'-11"	5'-6"	6'-1"	6'-8"	8'-0"	11300
		45"	3'-5"	3'-8"	3'-11"	4'-3"	4'-6"	4'-9"	5'-1"	6'-2"	8000
			5'-11"	6'-3"	6'-6"	6'-9"	7'-1"	7'-4"	7'-7"	8'-0"	11300
		60"	3'-5"	3'-8"	3'-11"	4'-3"	4'-6"	4'-9"	5'-1"	6'-2"	8000
			5'-11"	6'-3"	6'-6"	6'-9"	7'-1"	7'-4"	7'-7"	8'-0"	11300
237	14"	30"	2'-11"	3'-5"	3'-8"	3'-11"	4'-2"	4'-5"	4'-8"	5'-8"	8000
			2'-11"	3'-6"	4'-1"	4'-7"	5'-2"	5'-9"	6'-3"	8'-0"	11300
		45"	3'-2"	3'-5"	3'-8"	3'-11"	4'-2"	4'-5"	4'-8"	5'-8"	8000
			5'-6"	5'-9"	6'-0"	6'-3"	6'-6"	6'-9"	7'-0"	8'-0"	11300
		60"	3'-2"	3'-5"	3'-8"	3'-11"	4'-2"	4'-5"	4'-8"	5'-8"	8000
			5'-6"	5'-9"	6'-0"	6'-3"	6'-6"	6'-9"	7'-0"	8'-0"	11300
264	16"	30"	2'-9"	3'-2"	3'-4"	3'-7"	3'-10"	4'-1"	4'-3"	5'-3"	8000
			2'-9"	3'-4"	3'-10"	4'-4"	4'-10"	5'-5"	5'-11"	7'-5"	11300
		45"	2'-11"	3'-2"	3'-4"	3'-7"	3'-10"	4'-1"	4'-3"	5'-3"	8000
			5'-1"	5'-4"	5'-6"	5'-9"	6'-0"	6'-3"	6'-5"	7'-5"	11300
		60"	2'-11"	3'-2"	3'-4"	3'-7"	3'-10"	4'-1"	4'-3"	5'-3"	8000
			5'-1"	5'-4"	5'-6"	5'-9"	6'-0"	6'-3"	6'-5"	7'-5"	11300
290	18"	30"	2'-7"	2'-11"	3'-1"	3'-4"	3'-7"	3'-9"	4'-0"	4'-10"	8000
			2'-7"	3'-1"	3'-7"	4'-1"	4'-7"	5'-1"	5'-7"	6'-10"	11300
		45"	2'-8"	2'-11"	3'-1"	3'-4"	3'-7"	3'-9"	4'-0"	4'-10"	8000
			4'-9"	4'-11"	5'-2"	5'-4"	5'-7"	5'-9"	6'-0"	6'-10"	11300
		60"	2'-8"	2'-11"	3'-1"	3'-4"	3'-7"	3'-9"	4'-0"	4'-10"	8000
			4'-9"	4'-11"	5'-2"	5'-4"	5'-7"	5'-9"	6'-0"	6'-10"	11300
317	20"	30"	2'-5"	2'-9"	2'-11"	3'-1"	3'-4"	3'-6"	3'-9"	4'-6"	8000
			2'-5"	2'-11"	3'-4"	3'-10"	4'-3"	4'-9"	5'-3"	6'-5"	11300
		45"	2'-6"	2'-9"	2'-11"	3'-1"	3'-4"	3'-6"	3'-9"	4'-6"	8000
			4'-5"	4'-7"	4'-10"	5'-0"	5'-3"	5'-5"	5'-7"	6'-5"	11300
		60"	2'-6"	2'-9"	2'-11"	3'-1"	3'-4"	3'-6"	3'-9"	4'-6"	8000
			4'-5"	4'-7"	4'-10"	5'-0"	5'-3"	5'-5"	5'-7"	6'-5"	11300

**NOTES:**

- Design load calculations for the above bracket spacings are based on a dead load of 160 pcf for the concrete and formwork, a live load of 50 psf for workers, moveable equipment and materials, plus a 75 plf vertical load applied at the outside edge of the deck overhang. A 50 psf live load is also applied to the walkway area.
- Always check overhang form lumber to make sure it will span the selected bracket spacing.
- For a nominal charge, Dayton Superior Technical Assistance will calculate a recommended bracket spacing when conditions on your specific project vary from those shown.

## C89L Bridge Overhang Bracket and Exterior Hanger Spacing

Over 3'-0" to 4'-0" Overhangs on Precast/Prestressed Concrete Girders

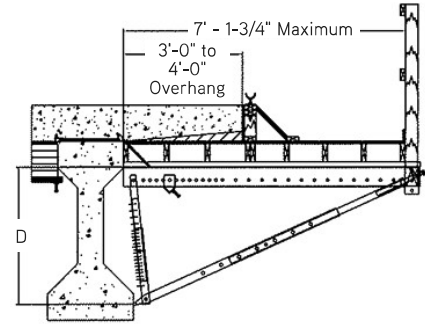

Bridge Overhang Brackets

Design Load PSF	Maximum Overhang Thickness	Bracket "D" Dimension	Screed Load Per Bracket = S <sub>i</sub>								Hanger SWL Range (lbs.)
			2,500 lbs.	2,250 lbs.	2,000 lbs.	1,750 lbs.	1,500 lbs.	1,250 lbs.	1,000 lbs.	0 lbs.	
130	6"	30"	1'-3"	1'-11"	2'-8"	3'-5"	4'-2"	4'-10"	5'-7"	7'-5"	8000
			1'-3"	1'-11"	2'-8"	3'-5"	4'-2"	4'-10"	5'-7"	8'-0"	11300
		45"	4'-2"	4'-6"	4'-10"	5'-2"	5'-6"	5'-9"	6'-1"	7'-5"	8000
			5'-5"	6'-2"	6'-11"	7'-7"	8'-0"	8'-0"	8'-0"	8'-0"	11300
		60"	4'-2"	4'-6"	4'-10"	5'-2"	5'-6"	5'-9"	6'-1"	7'-5"	8000
			7'-3"	7'-7"	7'-11"	8'-0"	8'-0"	8'-0"	8'-0"	8'-0"	11300
157	8"	30"	1'-1"	1'-10"	2'-6"	3'-2"	3'-10"	4'-6"	5'-2"	6'-6"	8000
			1'-1"	1'-10"	2'-6"	3'-2"	3'-10"	4'-6"	5'-2"	7'-10"	11300
		45"	3'-7"	3'-11"	4'-2"	4'-6"	4'-9"	5'-1"	5'-4"	6'-6"	8000
			5'-0"	5'-8"	6'-4"	7'-0"	7'-6"	7'-9"	8'-0"	8'-0"	11300
		60"	3'-7"	3'-11"	4'-2"	4'-6"	4'-9"	5'-1"	5'-4"	6'-6"	8000
			6'-4"	6'-7"	6'-11"	7'-2"	7'-6"	7'-9"	8'-0"	8'-0"	11300
184	10"	30"	1'-0"	1'-8"	2'-3"	2'-11"	3'-6"	4'-2"	4'-9"	5'-10"	8000
			1'-0"	1'-8"	2'-3"	2'-11"	3'-6"	4'-2"	4'-9"	7'-3"	11300
		45"	3'-3"	3'-6"	3'-9"	4'-0"	4'-3"	4'-6"	4'-9"	5'-10"	8000
			4'-8"	5'-3"	5'-11"	6'-5"	6'-8"	6'-11"	7'-2"	8'-0"	11300
		60"	3'-3"	3'-6"	3'-9"	4'-0"	4'-3"	4'-6"	4'-9"	5'-10"	8000
			5'-7"	5'-11"	6'-2"	6'-5"	6'-8"	6'-11"	7'-2"	8'-0"	11300
210	12"	30"	*	1'-6"	2'-1"	2'-8"	3'-3"	3'-10"	4'-3"	5'-3"	8000
			*	1'-6"	2'-1"	2'-8"	3'-3"	3'-10"	4'-5"	6'-9"	11300
		45"	2'-11"	3'-2"	3'-4"	3'-7"	3'-10"	4'-1"	4'-3"	5'-3"	8000
			4'-3"	4'-10"	5'-5"	5'-9"	6'-0"	6'-3"	6'-5"	7'-5"	11300
		60"	2'-11"	3'-2"	3'-4"	3'-7"	3'-10"	4'-1"	4'-3"	5'-3"	8000
			5'-1"	5'-4"	5'-6"	5'-9"	6'-0"	6'-3"	6'-5"	7'-5"	11300
237	14"	30"	*	1'-5"	1'-11"	2'-6"	3'-0"	3'-7"	3'-11"	4'-9"	8000
			*	1'-5"	1'-11"	2'-6"	3'-0"	3'-7"	4'-1"	6'-3"	11300
		45"	2'-8"	2'-10"	3'-1"	3'-3"	3'-6"	3'-8"	3'-11"	4'-9"	8000
			4'-0"	4'-6"	5'-0"	5'-3"	5'-5"	5'-8"	5'-10"	6'-9"	11300
		60"	2'-8"	2'-10"	3'-1"	3'-3"	3'-6"	3'-8"	3'-11"	4'-9"	8000
			4'-7"	4'-10"	5'-0"	5'-3"	5'-5"	5'-8"	5'-10"	6'-9"	11300
264	16"	30"	*	1'-4"	1'-10"	2'-4"	2'-10"	3'-4"	3'-7"	4'-4"	8000
			*	1'-4"	1'-10"	2'-4"	2'-10"	3'-4"	3'-10"	5'-9"	11300
		45"	2'-5"	2'-7"	2'-10"	3'-0"	3'-2"	3'-5"	3'-7"	4'-4"	8000
			3'-8"	4'-2"	4'-7"	4'-10"	5'-0"	5'-2"	5'-5"	6'-2"	11300
		60"	2'-5"	2'-7"	2'-10"	3'-0"	3'-2"	3'-5"	3'-7"	4'-4"	8000
			4'-3"	4'-5"	4'-7"	4'-10"	5'-0"	5'-2"	5'-5"	6'-2"	11300
290	18"	30"	*	1'-3"	1'-8"	2'-2"	2'-7"	3'-1"	3'-4"	4'-0"	8000
			*	1'-3"	1'-8"	2'-2"	2'-7"	3'-1"	3'-6"	5'-4"	11300
		45"	2'-3"	2'-5"	2'-7"	2'-9"	2'-11"	3'-1"	3'-4"	4'-0"	8000
			3'-5"	3'-11"	4'-3"	4'-5"	4'-7"	4'-9"	5'-0"	5'-8"	11300
		60"	2'-3"	2'-5"	2'-7"	2'-9"	2'-11"	3'-1"	3'-4"	4'-0"	8000
			3'-11"	4'-1"	4'-3"	4'-5"	4'-7"	4'-9"	5'-0"	5'-8"	11300
317	20"	30"	*	1'-2"	1'-7"	2'-0"	2'-5"	2'-10"	3'-1"	3'-9"	8000
			*	1'-2"	1'-7"	2'-0"	2'-5"	2'-10"	3'-3"	5'-0"	11300
		45"	2'-1"	2'-3"	2'-5"	2'-7"	2'-9"	2'-11"	3'-1"	3'-9"	8000
			3'-2"	3'-7"	3'-11"	4'-1"	4'-3"	4'-5"	4'-7"	5'-3"	11300
		60"	2'-1"	2'-3"	2'-5"	2'-7"	2'-9"	2'-11"	3'-1"	3'-9"	8000
			3'-7"	3'-9"	3'-11"	4'-1"	4'-3"	4'-5"	4'-7"	5'-3"	11300

**NOTES:**

- Design load calculations for the above bracket spacings are based on a dead load of 160 pcf for the concrete and formwork, a live load of 50 psf for workers, moveable equipment and materials, plus a 75 plf vertical load applied at the outside edge of the deck overhang. A 50 psf live load is also applied to the walkway area.
- Always check overhang form lumber to make sure it will span the selected bracket spacing.
- For a nominal charge, Dayton Superior Technical Assistance will calculate a recommended bracket spacing when conditions on your specific project vary from those shown.

## C89L Bridge Overhang Bracket and Exterior Hanger Spacing

Over 4'-0" to 5'-0" Overhangs on Precast/Prestressed Concrete Girders

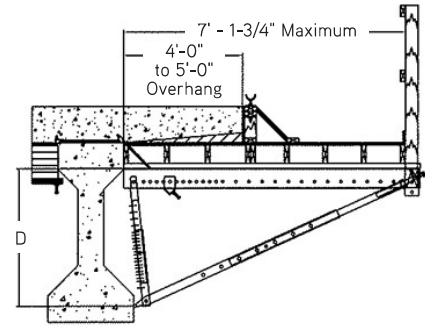

Design Load PSF	Maximum Overhang Thickness	Bracket "D" Dimension	Screed Load Per Bracket = S <sub>i</sub>							Hanger SWL Range (lbs.)	
			2,500 lbs.	2,250 lbs.	2,000 lbs.	1,750 lbs.	1,500 lbs.	1,250 lbs.	1,000 lbs.		0 lbs.
130	6"	30"	*	*	1'-1"	1'-9"	2'-6"	3'-3"	3'-11"	6'-8"	8000
			*	*	1'-1"	1'-9"	2'-6"	3'-3"	3'-11"	6'-10"	11300
		45"	3'-0"	3'-8"	4'-4"	4'-8"	4'-11"	5'-3"	5'-6"	6'-9"	8000
			3'-0"	3'-8"	4'-5"	5'-2"	5'-11"	6'-7"	7'-4"	8'-0"	11300
		60"	3'-9"	4'-0"	4'-4"	4'-8"	4'-11"	5'-3"	5'-6"	6'-9"	8000
			5'-10"	6'-6"	7'-2"	7'-5"	7'-9"	8'-0"	8'-0"	8'-0"	11300
157	8"	30"	*	*	*	1'-7"	2'-3"	2'-11"	3'-6"	5'-10"	8000
			*	*	*	1'-7"	2'-3"	2'-11"	3'-6"	6'-1"	11300
		45"	2'-8"	3'-4"	3'-9"	4'-0"	4'-3"	4'-6"	4'-9"	5'-10"	8000
			2'-8"	3'-4"	4'-0"	4'-7"	5'-3"	5'-11"	6'-7"	8'-0"	11300
		60"	3'-3"	3'-6"	3'-9"	4'-0"	4'-3"	4'-6"	4'-9"	5'-10"	8000
			5'-2"	5'-10"	6'-2"	6'-5"	6'-8"	6'-11"	7'-2"	8'-0"	11300
184	10"	30"	*	*	*	1'-5"	2'-0"	2'-7"	3'-2"	5'-1"	8000
			*	*	*	1'-5"	2'-0"	2'-7"	3'-2"	5'-6"	11300
		45"	2'-5"	3'-0"	3'-3"	3'-6"	3'-9"	3'-11"	4'-2"	5'-1"	8000
			2'-5"	3'-0"	3'-7"	4'-2"	4'-9"	5'-4"	5'-11"	7'-2"	11300
		60"	2'-10"	3'-1"	3'-3"	3'-6"	3'-9"	3'-11"	4'-2"	5'-1"	8000
			4'-8"	5'-2"	5'-5"	5'-7"	5'-10"	6'-1"	6'-4"	7'-2"	11300
210	12"	30"	*	*	*	1'-3"	1'-10"	2'-4"	2'-11"	4'-6"	8000
			*	*	*	1'-3"	1'-10"	2'-4"	2'-11"	5'-0"	11300
		45"	2'-2"	2'-9"	2'-11"	3'-1"	3'-4"	3'-6"	3'-9"	4'-6"	8000
			2'-2"	2'-9"	3'-3"	3'-9"	4'-4"	4'-10"	5'-4"	6'-5"	11300
		60"	2'-6"	2'-9"	2'-11"	3'-1"	3'-4"	3'-6"	3'-9"	4'-6"	8000
			4'-3"	4'-7"	4'-10"	5'-0"	5'-3"	5'-5"	5'-7"	6'-5"	11300
237	14"	30"	*	*	*	1'-2"	1'-8"	2'-2"	2'-8"	4'-1"	8000
			*	*	*	1'-2"	1'-8"	2'-2"	2'-8"	4'-7"	11300
		45"	2'-0"	2'-5"	2'-8"	2'-10"	3'-0"	3'-2"	3'-4"	4'-1"	8000
			2'-0"	2'-6"	2'-11"	3'-5"	3'-11"	4'-5"	4'-11"	5'-10"	11300
		60"	2'-3"	2'-5"	2'-8"	2'-10"	3'-0"	3'-2"	3'-4"	4'-1"	8000
			3'-10"	4'-2"	4'-4"	4'-6"	4'-8"	4'-11"	5'-1"	5'-10"	11300
264	16"	30"	*	*	*	1'-1"	1'-6"	2'-0"	2'-5"	3'-9"	8000
			*	*	*	1'-1"	1'-6"	2'-0"	2'-5"	4'-2"	11300
		45"	1'-10"	2'-3"	2'-5"	2'-7"	2'-9"	2'-11"	3'-1"	3'-9"	8000
			1'-10"	2'-3"	2'-8"	3'-2"	3'-7"	4'-0"	4'-6"	5'-3"	11300
		60"	2'-1"	2'-3"	2'-5"	2'-7"	2'-9"	2'-11"	3'-1"	3'-9"	8000
			3'-6"	3'-9"	3'-11"	4'-1"	4'-3"	4'-5"	4'-7"	5'-3"	11300
290	18"	30"	*	*	*	1'-0"	1'-5"	1'-10"	2'-3"	3'-5"	8000
			*	*	*	1'-0"	1'-5"	1'-10"	2'-3"	3'-10"	11300
		45"	1'-8"	2'-0"	2'-2"	2'-4"	2'-6"	2'-8"	2'-10"	3'-5"	8000
			1'-8"	2'-1"	2'-6"	2'-11"	3'-4"	3'-9"	4'-2"	4'-10"	11300
		60"	1'-11"	2'-0"	2'-2"	2'-4"	2'-6"	2'-8"	2'-10"	3'-5"	8000
			3'-3"	3'-6"	3'-7"	3'-9"	3'-11"	4'-1"	4'-3"	4'-10"	11300
317	20"	30"	*	*	*	*	1'-3"	1'-8"	2'-0"	3'-1"	8000
			*	*	*	*	1'-3"	1'-8"	2'-0"	3'-7"	11300
		45"	1'-6"	1'-11"	2'-0"	2'-2"	2'-4"	2'-5"	2'-7"	3'-2"	8000
			1'-6"	1'-11"	2'-4"	2'-8"	3'-1"	3'-5"	3'-10"	4'-6"	11300
		60"	1'-9"	1'-11"	2'-0"	2'-2"	2'-4"	2'-5"	2'-7"	3'-2"	8000
			3'-0"	3'-2"	3'-4"	3'-6"	3'-8"	3'-9"	3'-11"	4'-6"	11300

**NOTES:**

- Design load calculations for the above bracket spacings are based on a dead load of 160 pcf for the concrete and formwork, a live load of 50 psf for workers, moveable equipment and materials, plus a 75 plf vertical load applied at the outside edge of the deck overhang. A 50 psf live load is also applied to the walkway area.
- Always check overhang form lumber to make sure it will span the selected bracket spacing.
- For a nominal charge, Dayton Superior Technical Assistance will calculate a recommended bracket spacing when conditions on your specific project vary from those shown.

Bridge Overhang Brackets