

TECHNICAL DATA SHEET

DESCRIPTION

The D351 consists of a cylindrical steel body with a tapered threaded hole in its center.

APPLICATION

D351 is a class HA mechanical end anchor. The D351 end anchor disc simplifies rebar splicing in areas where rebar congestion prevents the use of lap splices or large diameter hooked rebar.

PRODUCT SPECIFICATION

- Extension of Taper- Lock product line
- Accommodates rebar sizes #4 through #18
- Available in Plain, Epoxy, Galvanized or Stainless Steel
- Minimizes development lengths
- Minimum head bearing area of 5x rebar diameter
- For use with grade 60, 75, 80 and 100 rebar
- IAPMO Evaluation Report ER-0245



ER-245
Grade 60, 75 & 80

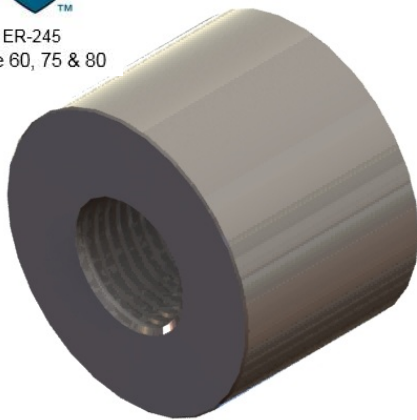

FEATURES

- Conforms to ASTM A-970, ACI, Cal Trans, IBC and Ministries of Transportation for Ontario and Quebec

BENEFITS

- Eliminates rebar congestion and aids in concrete placement
- Eliminates the need for hooked rebar
- Reduces engineering design time
- Simplifies load paths

TECHNICAL DATA

Bar Size			Diameter	Length
US	Metric (MM)	CN (M)		
#4	[13]	[10]	1.188	1.024
#5	[16]	[15]	1.438	1.220
#6	[19]	[20]	1.750	1.280
#7	[22]	-	2.000	1.398
#8	[25]	[25]	2.500	1.614
#9	[29]	[30]	2.750	1.811
#10	[32]	-	2.875	2.047
#11	[36]	[35]	3.250	2.264
#12	[40]	-	3.500	2.539
#14/#14B	[43]	[45]	4.000	2.717
#18/#18B	[57]	[556]	5.500	3.622

INSTALLATION

1. Ensure threads are clean, in good condition and conforms to gauge requirements as published in Taper-Lock Machine Operation manual before assembly
2. Assemble D351 disc onto rebar
3. Finish assembly by tightening D351 end anchor disc hand tight (5 foot-pounds)

HOW TO ORDER

- Specify: (1) quantity, (2) name, (3) rebar size, (4) finish, (5) Made in USA requirement.

Example: 500 pcs., D351 Taper-Lock® End Anchor Disc, #6, Black, Made in USA not required.

Additional sizes made to order. Please call for lead times, pricing and availability.

TECHNICAL DATA SHEET

ORDERING INFORMATION

TAPER-LOCK® END ANCHOR

Product Code	Description	Weight
128430	#4 [13MM] BLACK	0.27 LB
128431	#5 [16MM] BLACK	0.47 LB
128432	#6 [19MM] BLACK	0.67 LB
128433	#7 [22MM] BLACK	1.04 LB
128434	#8 [25MM] BLACK	1.52 LB
128435	#9 [29MM] BLACK	2.34 LB
128436	#10 [32MM] BLACK	3.15 LB
128437	#11 [36MM] BLACK	4.29 LB
145110	#12 [40MM] BLACK	5.71 LB
128438	#14 [43MM] BLACK	7.64 LB
128439	#18 [57MM] BLACK	18.82 LB
100606	#14B [43MM] BLACK	7.64 LB
100610	#18B [57MM] BLACK	18.82 LB
128420	#4 [13MM] EPOXY	0.27 LB
128423	#7 [22MM] EPOXY	1.04 LB
128428	#14 [43MM] EPOXY	7.64 LB
128429	#18 [57MM] EPOXY	18.82 LB

MANUFACTURER

Dayton Superior Corporation
 1125 Byers Road
 Miamisburg, OH 45342
 Customer Service: 888-977-9600
 Technical Services: 877-266-7732
 Website: www.daytonsuperior.com

WARRANTY (ACCESSORIES)

Limited Warranty. Dayton warrants, for a period of 60 days from the date of shipment (three years from the date of shipment in the case of formwork, excluding any consumable Products included with such formwork), that Products and any associated application drawings and engineering services provided by Dayton ("Ancillary Services") will be free from defects in material and workmanship and, in the case of custom designed formwork, that the formwork will meet the specifications set forth in the design drawings approved by Dayton and Customer. Any claim under this warranty must be made in writing within such warranty period. If any Product and/or Ancillary Service covered by a timely claim are found to be defective, Dayton will, within a reasonable time, make any necessary repairs or corrections or, at Dayton's option, replace the Product. Unless pre-authorized by Dayton in writing, Dayton will not accept any charges for correcting defects or accept the return of any Product. This warranty will not apply to any Products that have been subjected to misuse, neglect, storage damage, misapplication, accident or any other damage caused by any person other than Dayton, or that have not been maintained in accordance with Dayton's specifications. THIS LIMITED WARRANTY IS IN LIEU OF ALL OTHER WARRANTIES AS TO THE PRODUCTS AND ANCILLARY SERVICES. DAYTON MAKES NO OTHER WARRANTIES OR GUARANTEES, EXPRESS OR IMPLIED, INCLUDING ANY WARRANTY OF MERCHANTABILITY, FITNESS FOR A PARTICULAR PURPOSE OR OTHERWISE. THE REMEDIES SET FORTH IN THIS SECTION ARE CUSTOMER'S EXCLUSIVE REMEDY FOR BREACH OF WARRANTY.