

T-76 Double Strongback Plate

Dayton Superior produces two strongback plates. The T-76 Strongback Plate has holes spaced at 12" centers and is used with double inserts. The T-76-A Strongback Plate is used with inserts spaced at 8" centers.

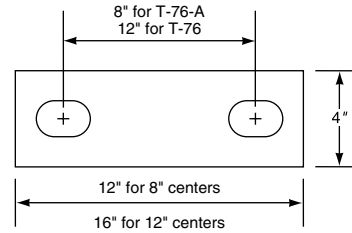

T-76 Double Strongback Plate

To Order:

Specify: (1) quantity, (2) name.

Example:

100, T-76 Strongback Plates

Alternate Strongbacking Methods

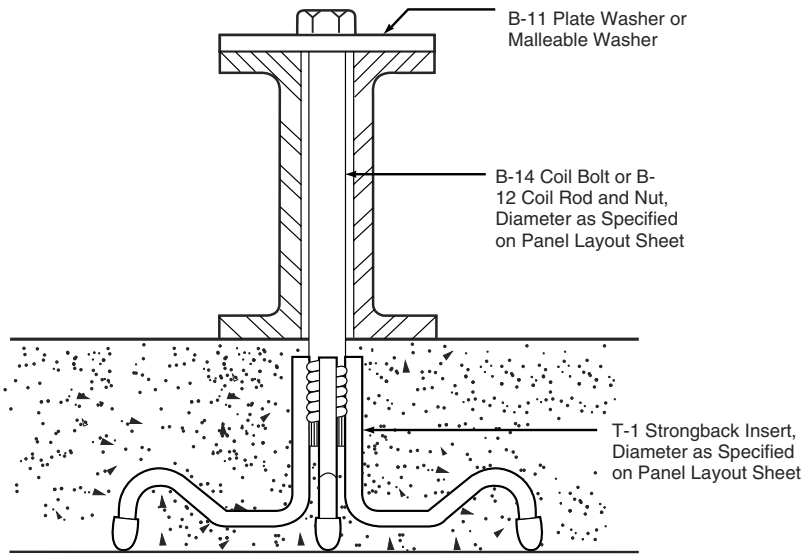

Single Strongback Insert and Bolt

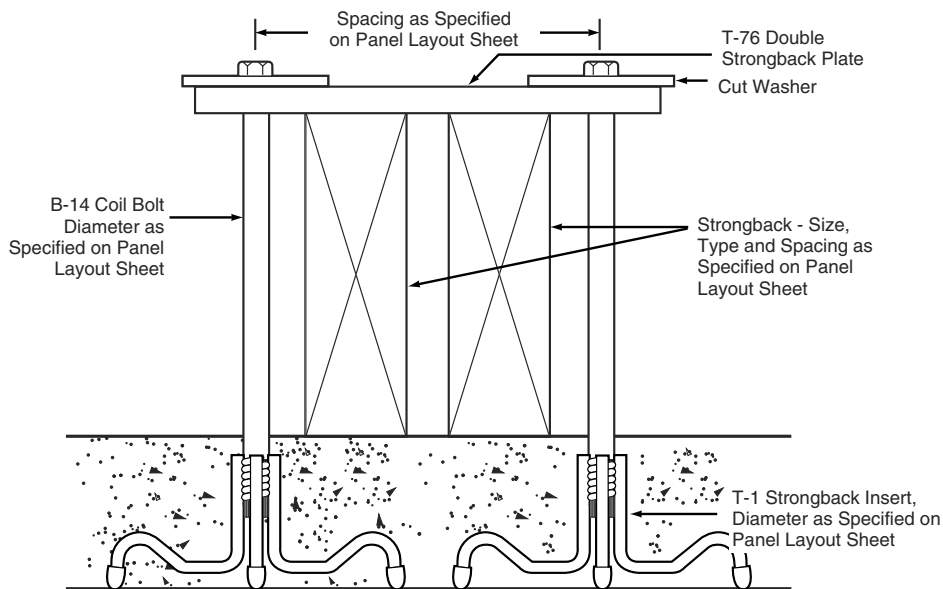

Double Strongback Insert and Bolt