

Coil Insert Safe Working Load Reduction Factors For Free Edge Conditions – Tension Loadings Only

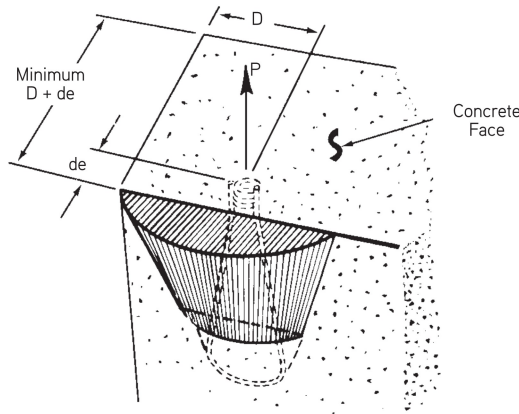

de = Free edge distance
 D = Minimum edge distance required to develop a full shear cone is 1.5 x the insert length
 2D = Minimum insert spacing when using two or more inserts
Note: For insert capacities under shear loading conditions, please refer to "Transverse and Shear Loading".

Insert Type and Length

de	B1 or B2			B16		B17	B18		B33	F53		F56 to F61				F63		
	6"	8"	12"	4"	6"	12"	9"	12"	12"	3"	4"	4-1/2"	5-1/2"	7-1/2"	9-1/2"	2-2/8"	3-1/2"	4-1/2"
2"	-	-	-	0.67	0.61	-	0.57	0.58	-	0.72	0.67	-	-	-	-	0.79	0.69	0.65
2-1/4"	0.63	0.59	0.59	0.69	0.63	-	0.58	0.59	-	0.75	0.69	0.67	-	-	-	0.82	0.71	0.67
2-1/2"	0.64	0.60	0.60	0.71	0.64	-	0.59	0.60	-	0.78	0.71	0.69	0.65	0.61	-	0.86	0.74	0.69
2-3/4"	0.65	0.61	0.61	0.73	0.65	-	0.60	0.61	-	0.81	0.73	0.70	0.67	0.62	0.60	0.90	0.76	0.70
3"	0.67	0.63	0.63	0.75	0.67	-	0.61	0.63	-	0.83	0.75	0.72	0.68	0.63	0.61	0.93	0.79	0.72
3-1/2"	0.69	0.65	0.65	0.79	0.69	-	0.63	0.65	-	0.89	0.79	0.76	0.71	0.66	0.62	1.00	0.83	0.76
4"	0.72	0.67	0.67	0.83	0.72	0.67	0.65	0.67	0.67	0.94	0.83	0.80	0.74	0.68	0.64	1.00	0.88	0.80
4-1/2"	0.75	0.69	0.69	0.88	0.75	0.69	0.67	0.69	0.69	1.00	0.88	0.83	0.77	0.70	0.66	1.00	0.93	0.83
5"	0.78	0.71	0.71	0.92	0.78	0.71	0.69	0.71	0.71	1.00	0.92	0.87	0.80	0.72	0.68	1.00	0.98	0.87
5-1/2"	0.81	0.73	0.73	0.96	0.81	0.73	0.70	0.73	0.73	1.00	0.96	0.91	0.83	0.74	0.69	1.00	1.00	0.91
6"	0.83	0.75	0.75	1.00	0.83	0.75	0.72	0.75	0.75	1.00	1.00	0.94	0.86	0.77	0.71	1.00	1.00	0.94
7"	0.89	0.79	0.79	1.00	0.89	0.79	0.76	0.79	0.79	1.00	1.00	1.00	0.92	0.81	0.75	1.00	1.00	1.00
8"	0.94	0.83	0.83	1.00	0.94	0.83	0.80	0.83	0.83	1.00	1.00	1.00	0.98	0.86	0.78	1.00	1.00	1.00
9"	1.00	0.88	0.88	1.00	1.00	0.88	0.83	0.88	0.88	1.00	1.00	1.00	1.00	0.90	0.82	1.00	1.00	1.00
10"	1.00	0.92	0.92	1.00	1.00	0.92	0.87	0.92	0.92	1.00	1.00	1.00	1.00	0.94	0.85	1.00	1.00	1.00
11"	1.00	0.96	0.96	1.00	1.00	0.96	0.91	0.96	0.96	1.00	1.00	1.00	1.00	0.99	0.89	1.00	1.00	1.00

Reduced Safe Working Load is based on 1/2" setback from face of concrete.
 For Safe Working Load on other insert loading conditions, contact a Dayton Superior Technical Service Department.
 Above chart modified from ACI 318 Appendix D method by using previous results from product testing.

How to Use Reduction Factors:

To obtain an insert's reduced safe working load for free edge conditions, multiply the safe working load listed in the insert selection chart by the appropriate reduction factor from the above chart. Do not apply these reduction factors to other types or sizes of inserts.

Example:

Using a B2 Coil Tie Insert 1" x 8" long in a 2-1/2" free edge condition, multiply concrete safe working load of 9,514 lbs. by a reduction factor of 0.6 to arrive at the reduced concrete safe working load of 5,708 lbs. which is less than insert mechanical capacity of 9,000 lbs. so use 5,708 lbs.

Coil Insert Safe Working Load Reduction Factors For Thin Wall Conditions – Tension Loadings Only

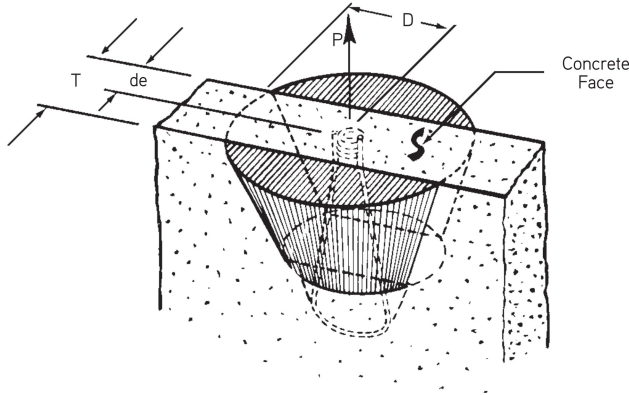

- T = Wall thickness
- de = Actual edge distance
- D = Minimum edge distance required to develop a full shear cone is 1.5 x the insert length
- 2D = Minimum insert spacing when using two or more inserts
- Note:** For insert capacities under shear loading conditions, please refer to *Selecting the Proper Insert* section.

Insert Type and Length

T	de	B1 or B2			B16		B17	B18		B33	F53		F56 to F61				F63		
		6"	8"	12"	4"	6"	12"	9"	12"	12"	3"	4"	4-1/2"	5-1/2"	7-1/2"	9-1/2"	2-2/8"	3-1/2"	4-1/2"
4"	2"	-	-	-	0.33	0.22	-	0.15	0.17	-	0.44	0.33	-	-	-	-	0.58	0.38	0.30
4-1/2"	2-1/4"	0.25	0.19	0.19	0.38	0.25	-	0.17	0.19	-	0.50	0.38	0.33	-	-	-	0.65	0.43	0.33
5"	2-1/2"	0.28	0.21	0.21	0.42	0.28	-	0.19	0.21	-	0.56	0.42	0.37	0.30	0.22	-	0.72	0.48	0.37
5-1/2"	2-3/4"	0.31	0.23	0.23	0.46	0.31	-	0.20	0.23	-	0.61	0.46	0.41	0.33	0.24	0.19	0.79	0.52	0.41
6"	3"	0.33	0.25	0.25	0.50	0.33	-	0.22	0.25	-	0.67	0.50	0.44	0.36	0.27	0.21	0.86	0.57	0.44
7"	3-1/2"	0.39	0.29	0.29	0.58	0.39	-	0.26	0.29	-	0.78	0.58	0.52	0.42	0.31	0.25	1.00	0.67	0.52
8"	4"	0.44	0.33	0.33	0.67	0.44	0.33	0.30	0.33	0.33	0.89	0.67	0.59	0.48	0.36	0.28	1.00	0.76	0.59
9"	4-1/2"	0.50	0.38	0.38	0.75	0.50	0.38	0.33	0.38	0.38	1.00	0.75	0.67	0.55	0.40	0.32	1.00	0.86	0.67
10"	5"	0.56	0.42	0.42	0.83	0.56	0.42	0.37	0.42	0.42	1.00	0.83	0.74	0.61	0.44	0.35	1.00	0.95	0.74
11"	5-1/2"	0.61	0.46	0.46	0.92	0.61	0.46	0.41	0.46	0.46	1.00	0.92	0.81	0.67	0.49	0.39	1.00	1.00	0.81
12"	6"	0.67	0.50	0.50	1.00	0.67	0.50	0.44	0.50	0.50	1.00	1.00	0.89	0.73	0.53	0.42	1.00	1.00	0.89
14"	7"	0.78	0.58	0.58	1.00	0.78	0.58	0.52	0.58	0.58	1.00	1.00	1.00	0.85	0.62	0.49	1.00	1.00	1.00
16"	8"	0.89	0.67	0.67	1.00	0.89	0.67	0.59	0.67	0.67	1.00	1.00	1.00	0.97	0.71	0.56	1.00	1.00	1.00
18"	9"	1.00	0.75	0.75	1.00	1.00	0.75	0.67	0.75	0.75	1.00	1.00	1.00	1.00	0.80	0.63	1.00	1.00	1.00
20"	10"	1.00	0.83	0.83	1.00	1.00	0.83	0.74	0.83	0.83	1.00	1.00	1.00	1.00	0.89	0.70	1.00	1.00	1.00
22"	11"	1.00	0.92	0.92	1.00	1.00	0.92	0.81	0.92	0.92	1.00	1.00	1.00	1.00	0.98	0.77	1.00	1.00	1.00

Reduced Safe Working Load is based on 1/2" setback from face of concrete.

For Safe Working Load on other insert loading conditions, contact a Dayton Superior Technical Service Department.

When an insert is not positioned at the center line of the wall, the effective wall thickness is twice the actual edge distance. Above chart modified from ACI 318 Appendix D method by using previous results from product testing.

How to Use Reduction Factors:

To obtain an insert's reduced safe working load for thin wall conditions, multiply the safe working load listed in the insert selection chart by the appropriate reduction factor from the above chart. Do not apply these reduction factors to other types or sizes of inserts.

Example:

Using a B2 Coil Tie Insert 1" x 12" long in an 8" thin wall, multiply concrete full shear cone capacity of 17,525 by a reduction factor of 0.33 to arrive at the reduced concrete safe working load of 5,783 lbs. which is less than insert mechanical capacity of 9,000 lbs. so use 5,783 lbs.