



**PERFORM
WITH
PRECISION™**

CURB SMART™

**CONCRETE
CONSTRUCTION
SOLUTIONS**

BROCHURE

 **DAYTON®
SUPERIOR**

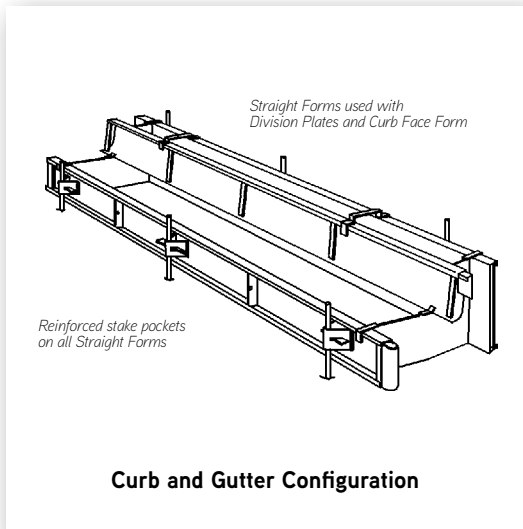
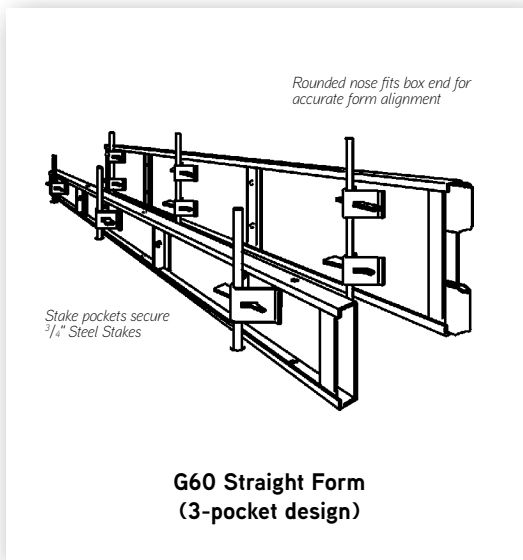

The Curb Smart forming system is versatile product that adapts to many concrete forming conditions. It is ideally suited for applications that include sidewalks, driveways, curb and gutters, pavements, footings and industrial slabs.

This system features durable steel components, with added reinforcement, for maximum service life. These components are precision welded to provide a system that lasts far longer than conventional lumber edge forms.

The productivity advantages of this forming system are obvious. The system adapts to different project conditions, reducing applied forming costs. A crew sets the system quickly and consistently, reducing related labor costs. The steel design eliminates lumber replacement costs, maximizing system reuse.

G60 Straight Forms

The G 60 Straight Form is available in 10' lengths, with heights ranging from 4" to 24", to satisfy almost any straight edge forming condition. Each form has reinforced stake pockets on the back to secure the 3/4" Steel Stakes which support the form during concrete placement. The rounded nose end connection on each form quickly fits into the box end on the next form for accurate alignment.

Straight Forms are often used as edge forms for concrete slabs. The bottom edge of the form rests on the subgrade or the stake pocket holds the form at the proper elevation. The top edge of the form provides a place for lightweight screed equipment used during concrete placement. Forms can also be stacked for thick concrete slabs.

Straight Forms are used for a variety of curb and gutter configurations. Curb dimensions establish the shape of the Division Plates (or Skeleton Plates) needed. These Plates are then positioned over the Straight Forms to support the Curb Face Form. The final concrete finish is applied after the Curb Face Form and Division Plates are removed (before final set).

Curb Forming System

- **Versatile components adapt to many different forming conditions**
- **Durable steel design lasts far longer than lumber edge forms**
- **System productivity reduces related labor and material costs**

G61 Flexible Forms

The G61 Flexible Form is available in 10' lengths, with heights ranging from 4" to 24", to satisfy almost any radius edge forming condition. Each form has seven reinforced stake pockets on the back side that secure 3/4" Steel Stakes and support the form during concrete placement. A simple end connection only requires a keybolt and wedge (or a nut and bolt) to secure one form to the next form.

Flexible Forms complement Straight Forms when concrete must be placed in radiused or curved applications. Transition Forms can be used to join the equipment and maximize forming system productivity.

Other Forms

Other forms are available to maximize productivity for unique forming conditions. Filler Forms are used to overlap Straight Forms and close edge form openings up to 5'. Corner Forms are used with Straight Forms for precise dimension corner forming. Batter Plates are used with Straight Forms to create a partial or full batter curb design.

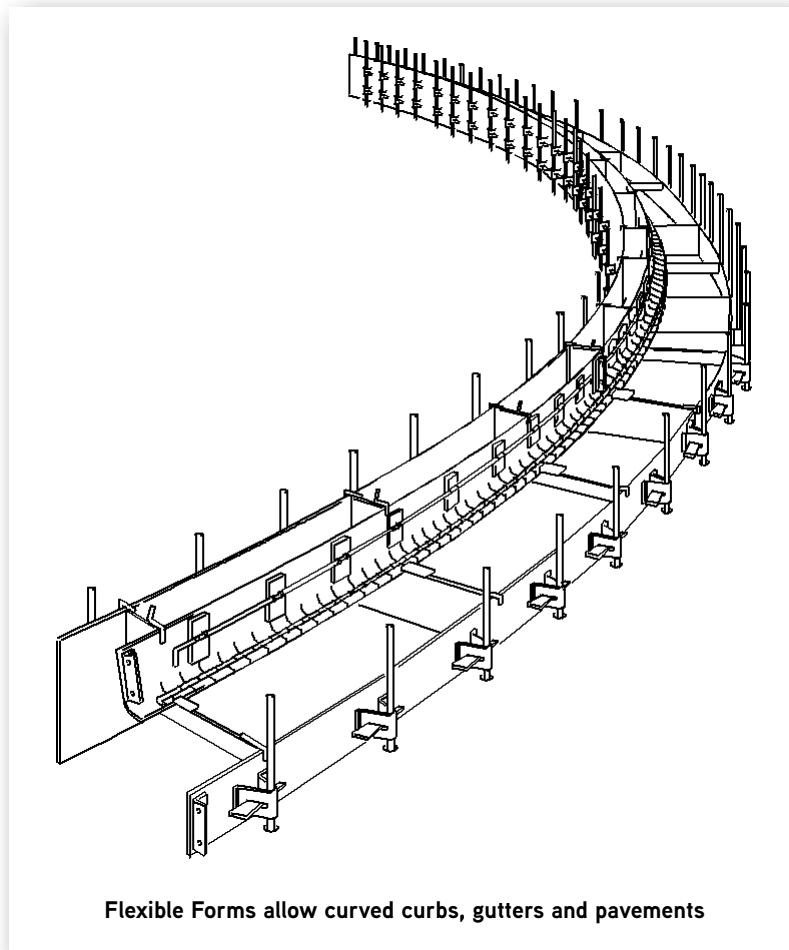

Flexible Forms allow curved curbs, gutters and pavements

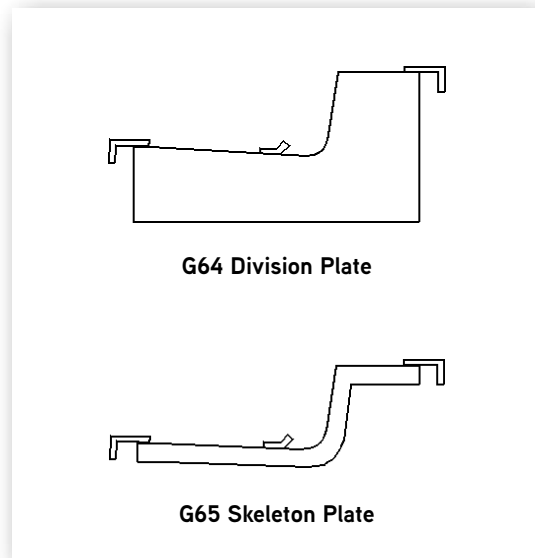

G64 Division Plate

G65 Skeleton Plate

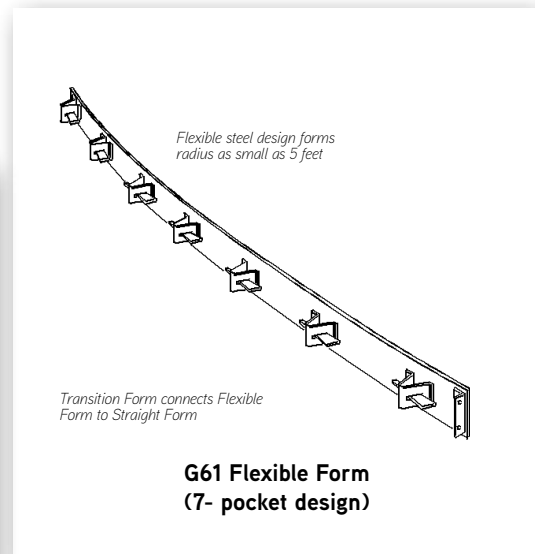

G61 Flexible Form (7- pocket design)

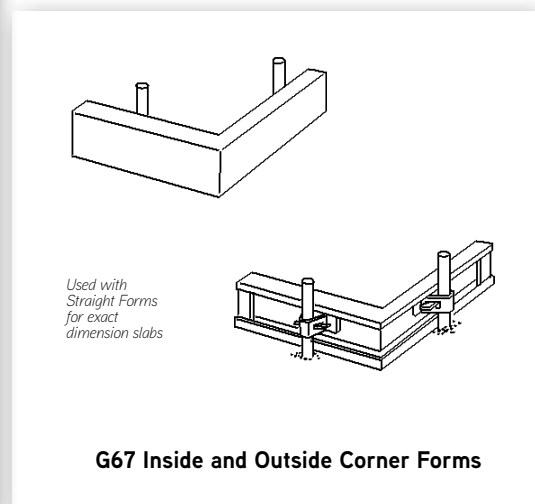

G67 Inside and Outside Corner Forms



DAYTON[®]
SUPERIOR

1125 Byers Road
Miamisburg, OH 45342
937-866-0711
888-977-9600

**PERFORM
WITH
PRECISION™**

DS42
03/16

Copyright © 2016 Dayton Superior Corporation, All Rights Reserved